

TOSHIBA

Air Conditioning Control System (Touch Screen Controller) Installation Manual

Model name:

BMS-CT1280E

BMS-CT1280E-TR

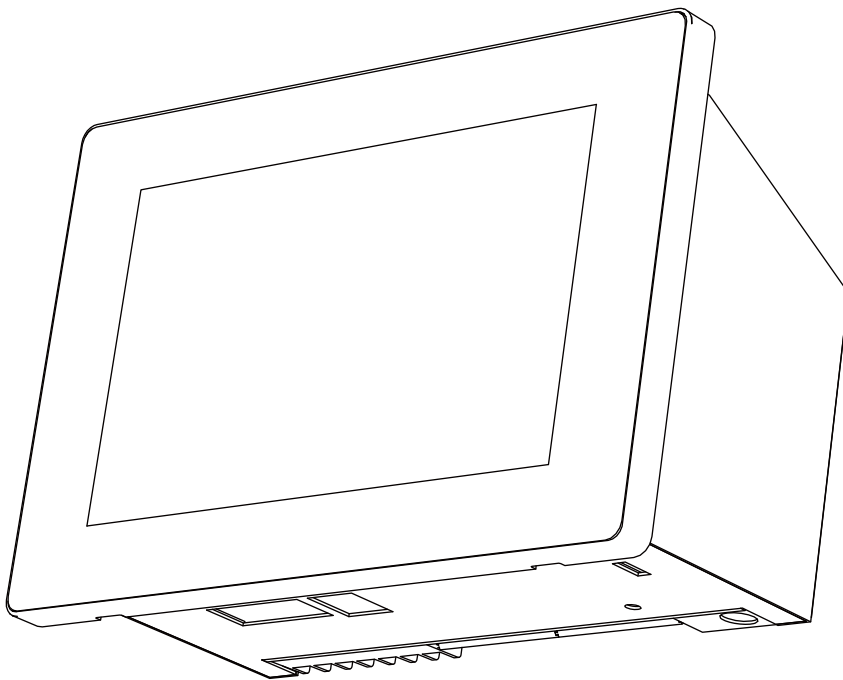

• Save These Instructions!

ENGLISH



•Thank you for purchasing the TOSHIBA air conditioning control system.
•Please read this installation manual carefully before installation, and perform the work only in the correct manner.

Contents





1	Precautions for safety	3
2	Specifications	5
3	Installation	8
3-1.	Installation of Main Unit Box and Panel	8
3-1-1.	When Installing from the Front	8
3-1-2.	When Installing from the Rear	9
3-2.	Attaching the Power Adapter	10
3-3.	Power, Signal, and Earth Line Connections	11

1 Precautions for safety



- Read these “Precautions for safety” carefully before installation.
- The precautions described below include important items regarding safety. Observe them without fail. Understand the following details (indications and symbols) before reading the body text, and follow the instructions.
- After the installation work has been completed, perform a trial operation to check for any problems. Explain how to use and maintain the unit to the customer.
Ask customer to keep this Manual at accessible place for future reference.

Indication	Meaning of Indication
 WARNING	Text set off in this manner indicates that failure to adhere to the directions in the warning could result in serious bodily harm (*1) or loss of life if the product is handled improperly.
 CAUTION	Text set off in this manner indicates that failure to adhere to the directions in the caution could result in serious bodily injury (*2) or damage (*3) to property if the product is handled improperly.

- *1: Serious bodily harm indicates loss of eyesight, injury, burns, electric shock, bone fracture, poisoning, and other injuries which leave aftereffect and require hospitalization or long-term treatment as an outpatient.
- *2: Bodily injury indicates injury, burns, electric shock, and other injuries which do not require hospitalization or long-term treatment as an outpatient.
- *3: Damage to property indicates damage extending to buildings, household effects, domestic livestock, and pets.

Symbols	Meaning of Symbols
	“  ” Indicates prohibited items. The actual contents of the prohibition are indicated by a picture or text placed inside or next to the graphic symbol.
	“  ” Indicates compulsory (mandatory) items. The actual contents of the obligation indicated by a picture or text placed inside or next to the graphic symbol.

WARNING

	<ul style="list-style-type: none"> • Ask an authorized dealer or qualified installation professional to install or reinstall this unit. Inappropriate installation may result in electric shock or fire. • Electrical work must be performed by a qualified electrician in accordance with this installation manual. The work must satisfy all local, national and international regulations. Inappropriate work may result in electric shock or fire. • Be sure to turn off all main power supply switches before starting any electrical work. Failure to do so may result in electric shock.
	<ul style="list-style-type: none"> • Do not modify the unit. A fire or an electric shock may occur.
	<ul style="list-style-type: none"> • Always connect to ground Improper grounding may result in an electric shock. Before connecting the power, carry out Class D grounding according to the “Engineering Standard for Electric Work” and the “Internal Wiring Regulations”.

Warning

This is a class A product. In a domestic environment this product may cause radio interference in which case the user may be required to take adequate measures.

 **CAUTION**

- **Do not install in the following locations:**
 - Locations where combustible gas may leak
 - Locations with high humidity or water
 - Dusty locations
 - Locations in direct sunlight and locations subject to high temperatures
 - Locations within 1 m from televisions or radios
 - Outdoors, under awnings, or other locations exposed to rain and dew
 - Locations exposed to outside air containing corrosive gases or salinity
 - Locations with frequent vibrations
- **Do not operate the touch panel with mechanical pencils or other pointed objects.**



- **In installation work, use wiring with the correct ampacity.**
Failure to do so may result in excessive heat or fire.
- **Use specified cables and connect them securely, and do not subject connecting terminals to external force.**
Doing so may result in broken cables, excessive heat or fire.
- **Always install a circuit breaker on the primary side of the power supply.**
- **Clean the touch panel by wiping with an eyeglasses cleaner or other soft cloth.**
To remove oil-based ink, wipe with a cloth that has been moistened with a neutral detergent and then wrung out, and finish by wiping with a soft, dry cloth.
Do not use commercial OA cleaners, cleansers, or other liquid cleaners containing abrasives.
- **When attaching to a metal lath, wire lath or wooden structure with metal boards, attach it to the control panel, etc. without attaching it to the wall.**

CAUTION This device uses a lithium battery. Follow all local regulations when disposing of it.

2 Specifications

Product name		Touch Screen Controller
Model Name		BMS-CT1280E / BMS-CT1280E-TR
Power supply		220-240 V AC* 50/60 Hz
Number of connected units	Indoor unit	Up to 128 units (TCC-LINK 1 maximum 64 units, TCC-LINK 2 maximum 64 units)
	Power meter interface	Up to 4 units
	Digital I/O interface	Up to 4 units
Communication ports		<ul style="list-style-type: none"> •RS-485 port ×1 •LAN port ×1
USB port		USB memory stick connection port ×2
External contact input		8 inputs
External contact output		4 outputs
Operating temperature/humidity range		0°C to 40°C, 10% to 90% RH (no condensation)
Dimensions		H136×W205×D10 (+80) (Embedded dimensions shown in parenthesis)
Mass		1.34 kg (Touch Screen Controller) 0.45 kg (power adapter)

* Power cord for 220-240 V power adapter is to be arranged on site.

■ Outline drawing

Air Conditioning Control System

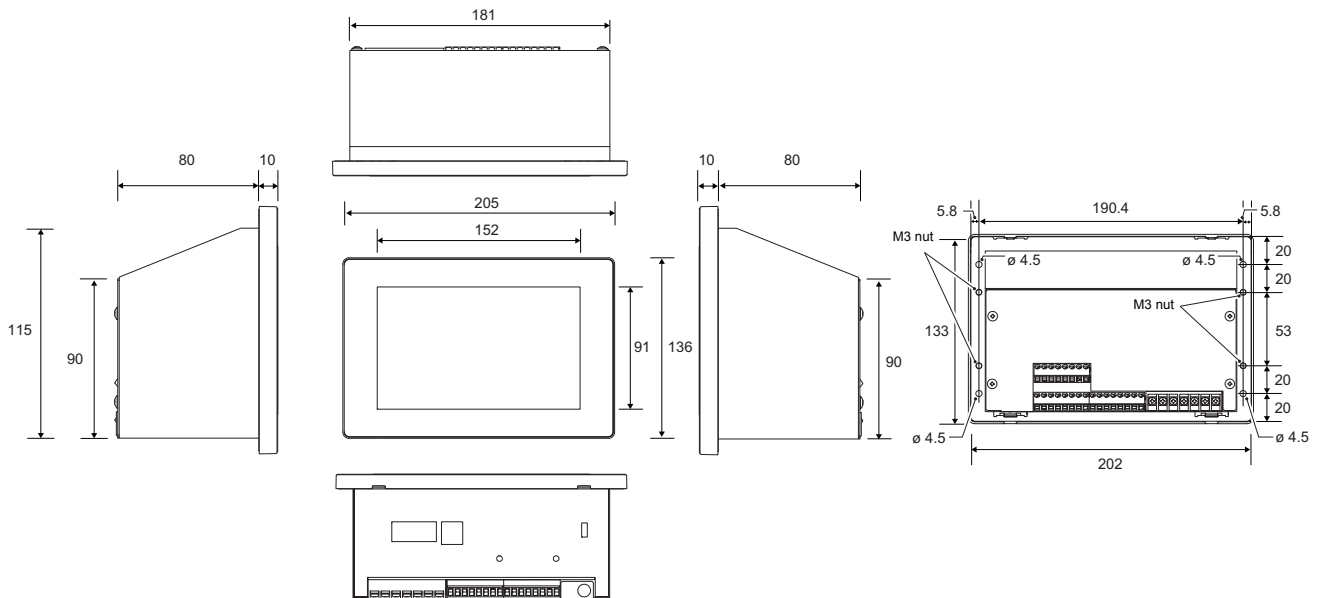

Power adapter

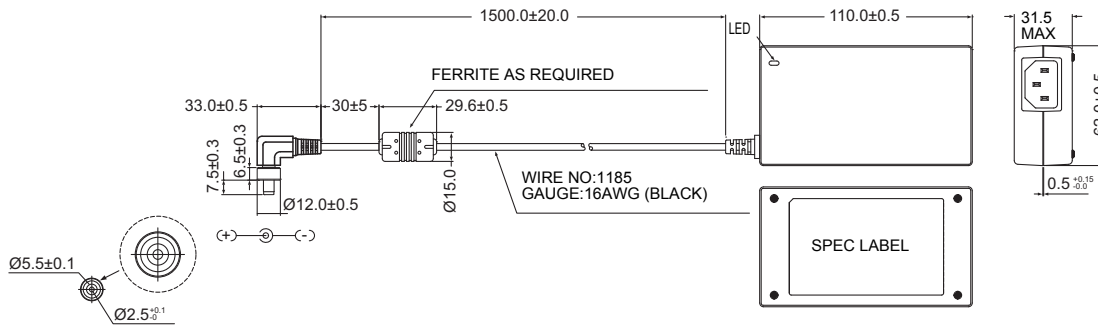

Component Names

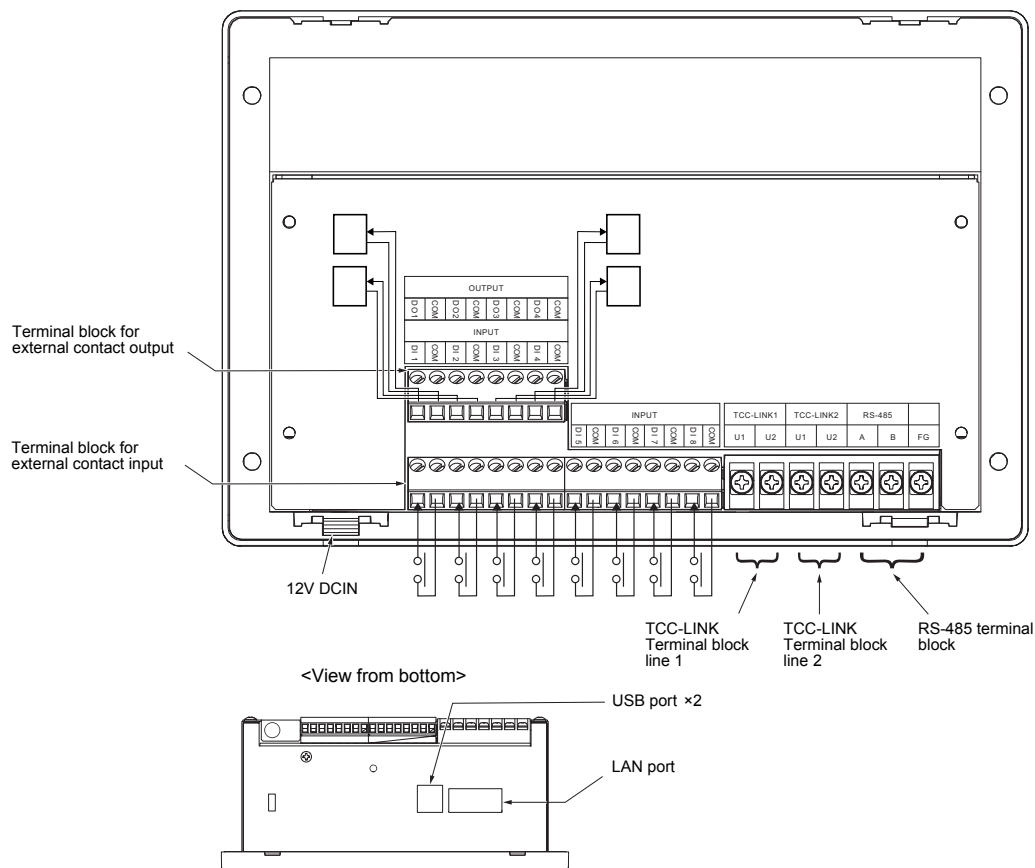

Name	Function
12V DCIN	Connect the power adapter
Terminal block for external contact output	Connect the external contact output
Terminal block for external contact input	Connect the external contact input
TCC-LINK terminal block	Connect the TCC-LINK 1 and TCC-LINK 2 signal wires
RS-485 terminal block	Connect the RS-485 terminal block
USB	For service
LAN	Can be connected to a PC via LAN communication and monitored and controlled

■ Before Installation

Confirm that all the parts listed below are included in the package.

Included Items

No.	Component name	Quantity	Remarks
1	Main unit	1	
2	Power adapter	1	
3	Owner's Manual	1	
4	Installation Manual	1	
5	DVD-R	1	<Included Items> <ul style="list-style-type: none"> • Owner's Manual • Installation Manual • Network Configuration Guide • Data Analyzer • Report Creation Software • Section Changeover Software
6	Fixing screw	4	Fixing screw (M4×12) for attaching the main unit from the front
7	Fixing screw	4	Fixing screw (M3×8) for attaching the main unit from the rear
8	Closed end connector	2	RS-485 cable crimp connector
9	Binding band	2	For fixing the power adapter
10	Double-sided tape	1	For fixing the power adapter

Wiring specifications

Use the following wiring material to connect signal wires and power supply wires. (Locally procured)

No.	Wiring	Wire type / wire diameter / wire length
1	For TCC-LINK	Microphone cord (shielded) (two-core) for instrumentation
		1.25 mm ² , up to 1000 m (total extension distance)
		2.00 mm ² , up to 2000 m (total extension distance)
2	For RS-485	Microphone cord (shielded) (two-core) for instrumentation
		1.25 mm ² , up to 500 m (total extension distance)
3	For digital I/O	Two-core cable 0.3 mm ² , up to 100 m
4	For Ethernet	LAN cable (category 5 or above) Maximum length: 100 m

3 Installation

⚠ CAUTION

- Do not wire communication lines or input/output wiring next to power supply wiring, etc., or house them in the same metal pipe. Doing so may result in failure.
- Install the main unit away from noise sources.

3-1. Installation of Main Unit Box and Panel

The main unit box can be mounted either from the front or from the rear.

3-1-1. When Installing from the Front

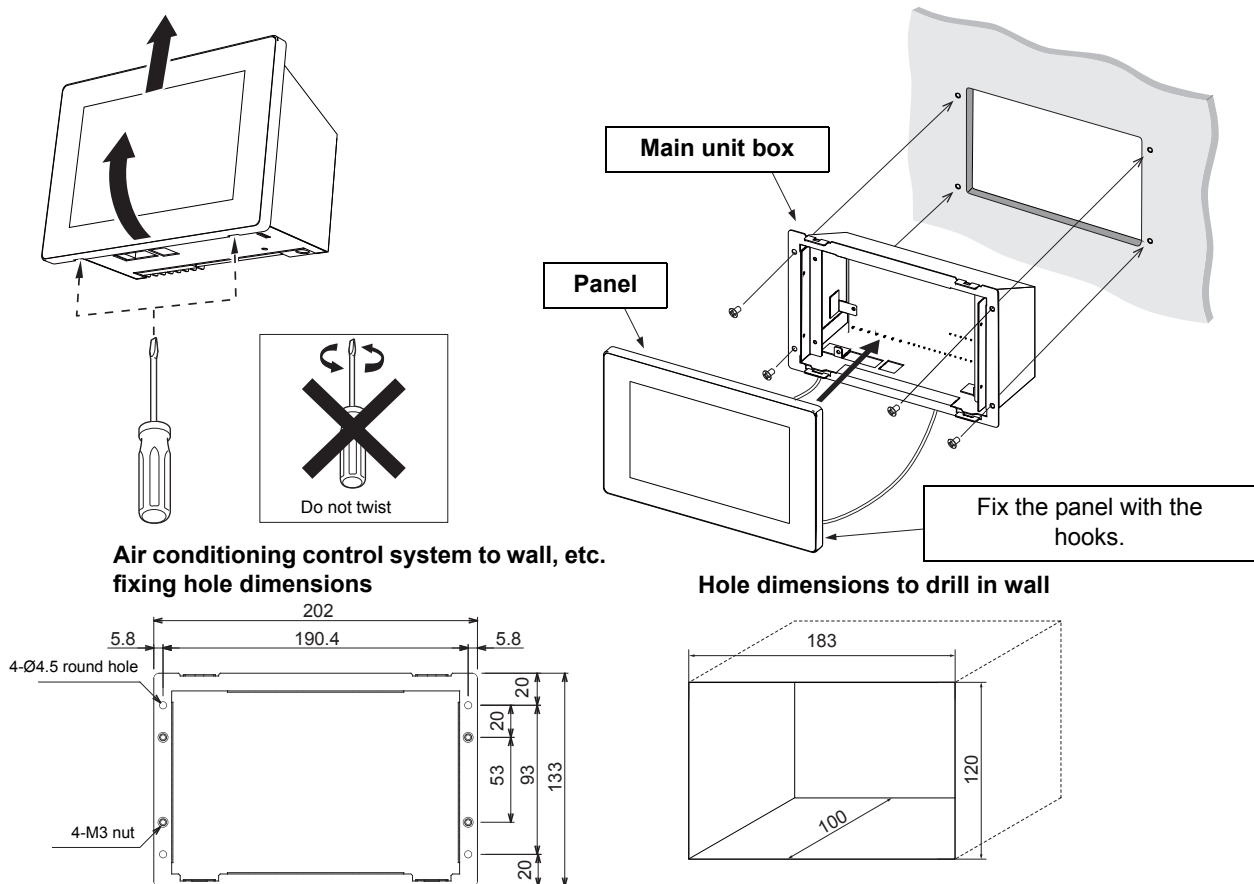

* Since the left and right mounting screws are attached close to each other, please drill the left and right dimensions as accurately as possible.

- 1 Connect the TCC-LINK cable, AC adapter, and LAN cable to the main unit.
- 2 Fit the main unit on to the wall and switch board.
- 3 Insert a flat head screwdriver, etc. into the groove on the left and right of the bottom of the panel. There will be a snapping sound and the panel will come off.

REQUIREMENT

- Just insert the screwdriver and do not twist it.
- To prevent the panel from falling, support it during removal.

- 4 Fix the 4 main unit screws.
- 5 Close the panel by hooking the panel rear to the top of the main unit. There will be a snapping sound and the panel will be fixed.
- 6 When installation is completed, peel off the transparent film.

3-1-2. When Installing from the Rear

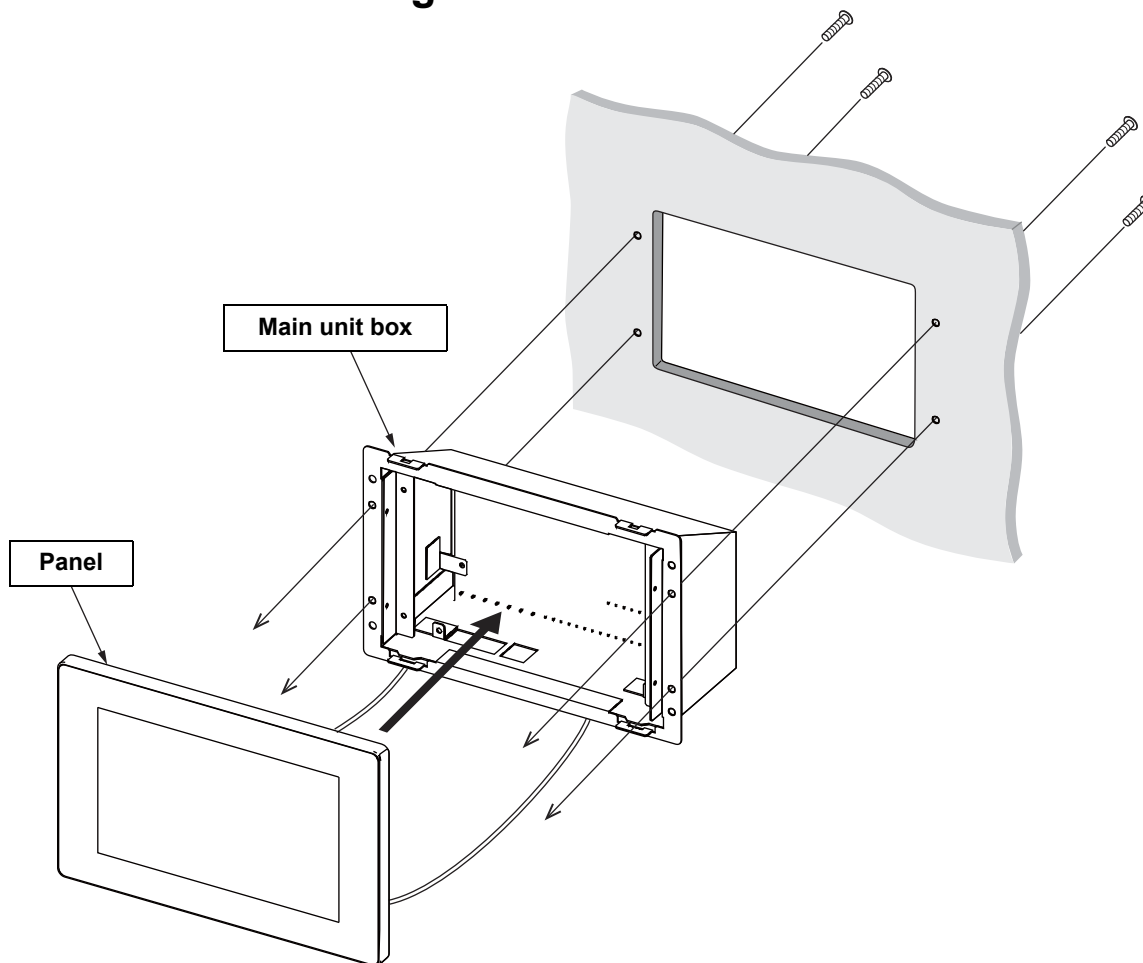

EN

Air conditioning control system to wall, etc. fixing hole dimensions

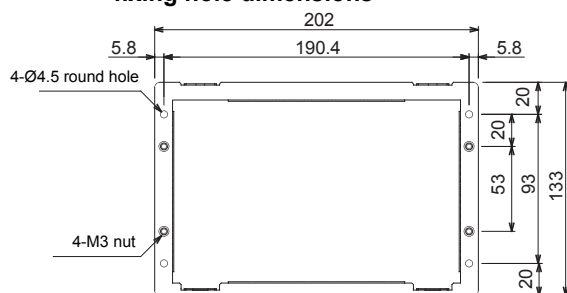

Hole dimensions to drill in wall

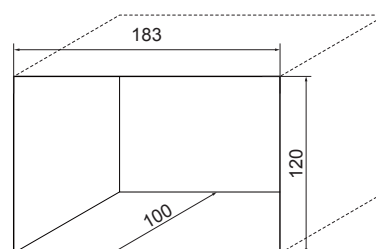

* Although the panel and the main unit box are separated to explain the screw attachment part in an easy to understand manner, it is not necessary to remove the main unit box from the panel in actual installation work.

- 1** Drill four Ø4 holes in the switchboard, wall, etc.
- 2** Fit the main unit on the switch board, wall, etc.
- 3** Fix from the rear of the main unit. Please use the supplied M3 × 8 screws.
- 4** Connect the TCC-LINK cable, AC adapter, and LAN cable to the main unit.
- 5** When installation is completed, peel off the transparent film.

3-2. Attaching the Power Adapter

The power adapter can be installed on a flat surface or on a wall. Do not install it in any other orientation. Fix with the attached binding band and double-sided tape.

Installation allowed

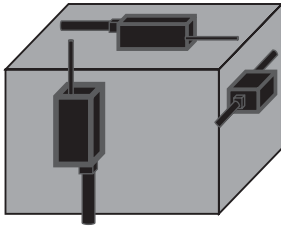

Installation not allowed

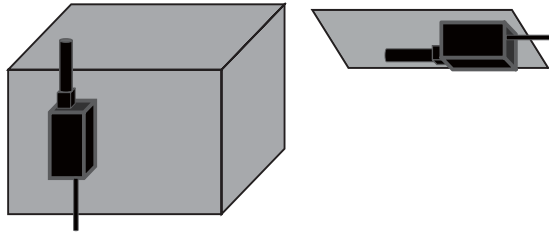

* Install so that the power cable that connects to 220-240 V AC does not face upward.

REQUIREMENT

Do not install in the following locations.

- Locations with high humidity or water
- Dusty locations
- Locations in direct sunlight and locations subject to high temperatures
- Locations within 1 m from televisions or radios
- Outdoors, under awnings, or other locations exposed to rain and dew

3-3. Power, Signal, and Earth Line Connections

Connect the power, signal and earth lines to the specified terminal blocks.

REQUIREMENT

Attach round crimp terminals to all TCC-LINK 1, TCC-LINK 2, and RS-485 wiring, and tighten the screws securely. After tightening, check that the wiring cannot come out.

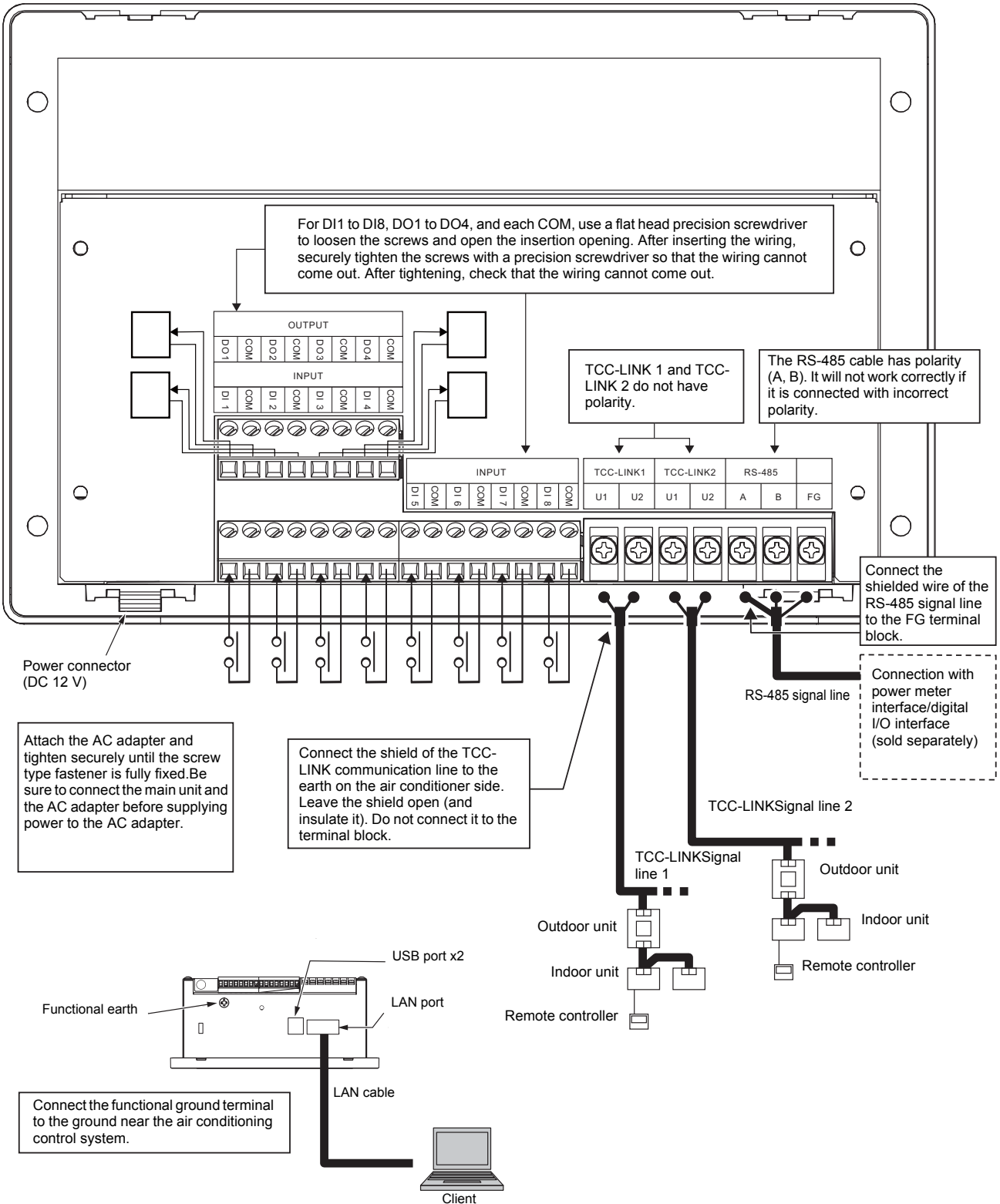

EN

TCC-LINK communication line stripping length

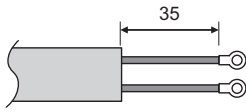

RS-485 cable wire stripping length

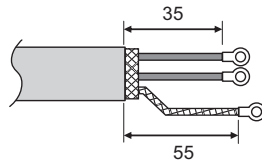

Digital I/O cable stripping length

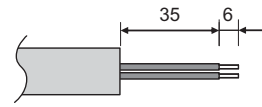

Attach a round crimp terminal to each wire of the power line and signal line.

Loosen the screws with a screwdriver, insert the digital I/O cable, and tighten the screws securely.

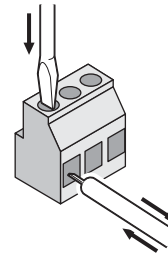
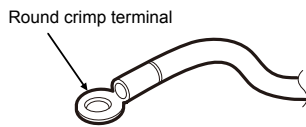

Termination resistance setting

- RS-485 termination resistance settingSet at both ends of the RS-485 communication line. Set one end at the main unit and the other end at the interface. The termination resistance of the main unit is already set as a factory default. Refer to the interface installation manual to set the termination resistance of the interface.
- TCC-LINK termination resistance settingSet on the air conditioner. The TCC-LINK termination resistance is not set in the main unit. Leave "open".

Shield grounding process

- RS-485 cable wire shielded wire Connect to the FG terminal block.
- TCC-LINK communication cable shielded wireWhen using the air conditioning control system with one unit, open the shielded wire of the TCC-LINK communication cable and perform insulation processing.
When using the air conditioning control system with multiple units, connect the shield of the TCC-LINK communication line to the closed end and open the shield at the final end of the air conditioning control system to perform insulation processing.
Perform TCC-LINK communication line shield grounding on the air conditioner side.

REQUIREMENT

- Be sure to install a circuit breaker or all-pole isolating switch (with a contact breaking distance of at least 3 mm) on the primary side of the power supply.
- Fasten the screws to the terminal block with torque of 0.5 N•m.

■ Connection to External Devices

Example of connection to external equipment which is connected to digital input/output terminal.

Name	I/O Item	Air conditioning control system side		External device side			
		I/O conditions	Terminal name	Circuit example	I/O conditions		
DO1 Output common	State output	Contact permissible voltage/current 24 V DC/35 mA	DO1			Wiring length: Within 100 m	
DO2 Output common			DO2				Output common
DO3 Output common			DO3				Output common
DO4 Output common			DO4				Output common
DI1 Input common	Control input	No-voltage contact A Pulse or static * No-voltage contacts compatible with very small current should be selected 5 V DC/3 mA	DI1			Pulse width: 50 msec or more Wiring length: Within 100 m	
DI2 Input common			DI2				Input common
DI3 Input common			DI3				Input common
DI4 Input common			DI4				Input common
DI5 Input common			DI5				Input common
DI6 Input common			DI6				Input common
DI7 Input common			DI7				Input common
DI8 Input common			DI8				Input common

- * Wire the cables so that the user does not touch the power supply directly.
- * On the external device side, use a basically insulated power circuit and place it in a location where the user cannot touch it.

EN

■ Wiring connections

This section shows wiring connection examples with the indoor units, power meter interface, digital I/O interface, and remote monitoring PC.

Air conditioning unit group settings

- Indoor units can be set together for each group unit.
- There is a TCC-LINK 1 and a TCC-LINK 2 for each TCC-LINK communication line. There are 64 groups in each line, and there are 128 groups and 128 zones for TCC-LINK 1 and TCC-LINK 2 together.

Interface connection

Connect the power meter interface and the digital I/O interface to the RS-485 cable line. For details of the connection method refer to the interface installation manual.

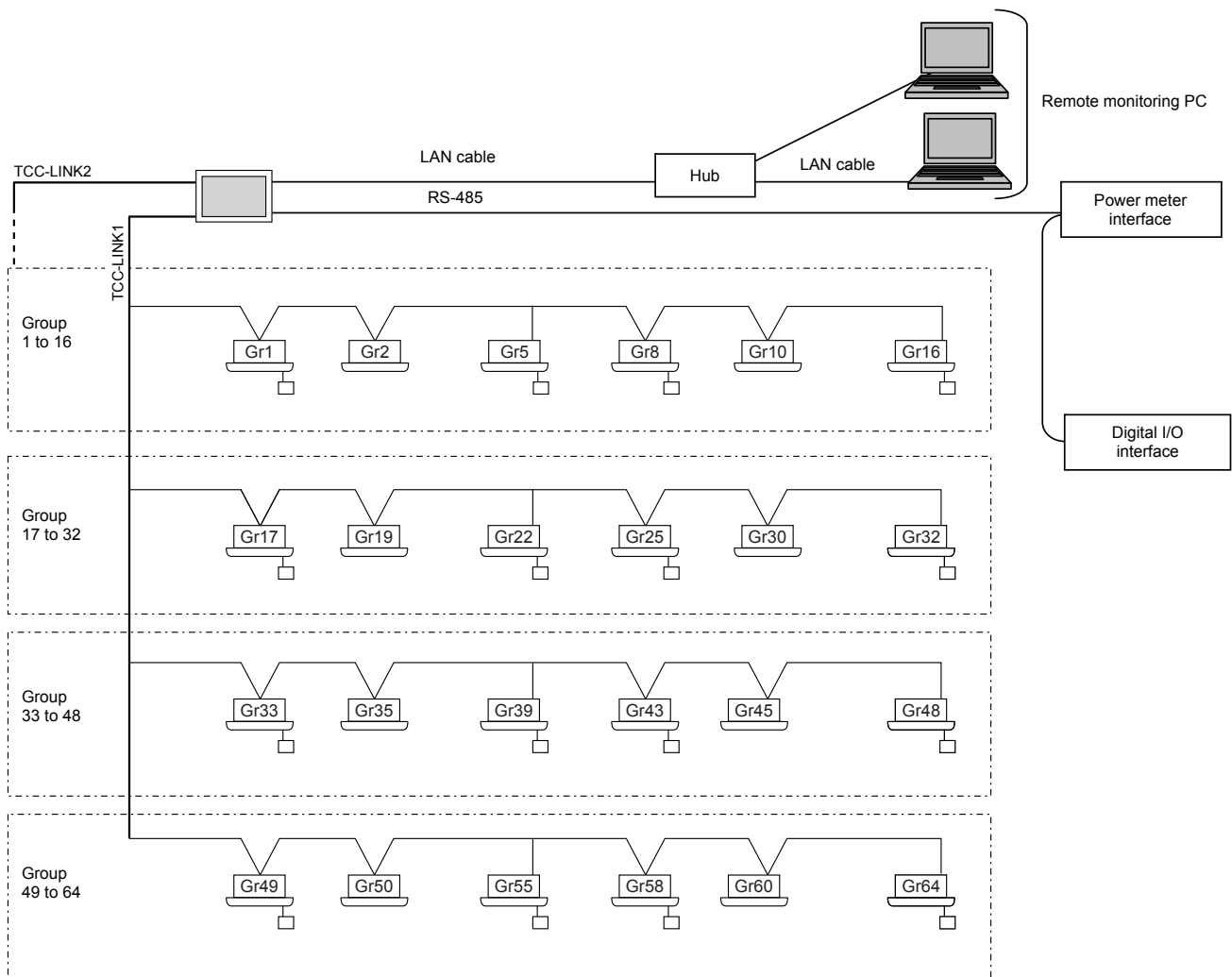

Gr = Group

NOTE

Set the termination resistance of TCC-LINK 1 and 2 at the air conditioner.
When you remove the rear panel of this Unit, there is SW100 which is the termination resistance of TCC-LINK 1 and 2.
In both cases, please use in the "Open": OFF state.

MEMO

A large area of horizontal dotted lines provided for writing a memo.

EN

TOSHIBA CARRIER CORPORATION
336 TADEHARA, FUJI-SHI, SHIZUOKA-KEN 416-8521 JAPAN