





SMART Touch Controller



Contents

Important Information	4
1. Product Overview	5
2. Connection Details	6
2.1. Power Supply	6
2.2. HVAC Communications Network (TCC-LINK)	6
2.3. Digital Input/Output	7
2.3.1. Digital Inputs	7
2.3.2. Digital Outputs	7
2.4. USB	7
2.5. Ethernet	7
2.6. Firmware	7
3. Air-Conditioning Address Configuration	8
4. Dimensions	10
5. User Interface	11
5.1. Start-Up	11
5.2. SMART Touch View Options	11
5.3. Grid View	11
5.4. List View	12
5.5. Icon	12
5.6. Global Control	13
5.7. Unit Control	13
5.8. Configuration	14
5.9. Network Setting	14
5.10. Time Setting	15
5.11. Group/Zone Configuration	15
5.12. Schedule Setup	16
5.13. System Logs	19
6. Version History and New Features Guide	20
6.1. Version Information	20
6.2. v1.04.01 Update Details	21
6.3. Security Features	22
6.4. Security Status Indicators	22
6.5. Security Configuration Screen	23
6.6. Security Settings	23
6.7. v1.04.02 update details	24
6.8. HVAC Settings	25
6.9. Scheduler Settings	26
6.10. v1.05.01 Update Details	27
6.11. Annual Schedules	28
6.12. Creating and Editing a Schedule	28
6.13. Assigning Groups to an Annual Schedule	29
6.14. Backup and Restore	30
6.15. Backup Current Configuration	30
6.16. Restore from Backup	31
7. Connection to an Internet Browser	32
7.1. Connection	32
7.2. IP Configuration	33
7.2. Browser Connection	33
8. Trouble Shooting Error Codes	34

■ Warning Indications on the Air Conditioner Unit

Warning indication	Description						
 <table border="1" data-bbox="325 365 683 591"> <tr> <td colspan="2" style="text-align: center;">WARNING</td> </tr> <tr> <td colspan="2">ELECTRICAL SHOCK HAZARD</td> </tr> <tr> <td colspan="2">Disconnect all remote electric power supplies before servicing.</td> </tr> </table>	WARNING		ELECTRICAL SHOCK HAZARD		Disconnect all remote electric power supplies before servicing.		<p>WARNING</p> <p>ELECTRICAL SHOCK HAZARD Disconnect all remote electric power supplies before servicing.</p>
WARNING							
ELECTRICAL SHOCK HAZARD							
Disconnect all remote electric power supplies before servicing.							
 <table border="1" data-bbox="325 703 683 929"> <tr> <td colspan="2" style="text-align: center;">WARNING</td> </tr> <tr> <td colspan="2">Moving parts. Do not operate unit with grille removed. Stop the unit before the servicing.</td> </tr> </table>	WARNING		Moving parts. Do not operate unit with grille removed. Stop the unit before the servicing.		<p>WARNING</p> <p>Moving parts. Do not operate unit with grille removed. Stop the unit before the servicing.</p>		
WARNING							
Moving parts. Do not operate unit with grille removed. Stop the unit before the servicing.							
 <table border="1" data-bbox="325 1057 683 1283"> <tr> <td colspan="2" style="text-align: center;">CAUTION</td> </tr> <tr> <td colspan="2">High temperature parts. You might get burned when removing this panel.</td> </tr> </table>	CAUTION		High temperature parts. You might get burned when removing this panel.		<p>CAUTION</p> <p>High temperature parts. You might get burned when removing this panel.</p>		
CAUTION							
High temperature parts. You might get burned when removing this panel.							
 <table border="1" data-bbox="325 1411 683 1637"> <tr> <td colspan="2" style="text-align: center;">CAUTION</td> </tr> <tr> <td colspan="2">Do not touch the aluminum fins of the unit. Doing so may result in injury.</td> </tr> </table>	CAUTION		Do not touch the aluminum fins of the unit. Doing so may result in injury.		<p>CAUTION</p> <p>Do not touch the aluminium fins of the unit. Doing so may result in injury.</p>		
CAUTION							
Do not touch the aluminum fins of the unit. Doing so may result in injury.							
 <table border="1" data-bbox="325 1765 683 1991"> <tr> <td colspan="2" style="text-align: center;">CAUTION</td> </tr> <tr> <td colspan="2">BURST HAZARD</td> </tr> <tr> <td colspan="2">Open the service valves before the operation, otherwise there might be the burst.</td> </tr> </table>	CAUTION		BURST HAZARD		Open the service valves before the operation, otherwise there might be the burst.		<p>CAUTION</p> <p>BURST HAZARD Open the service valves before the operation, otherwise there might be the burst.</p>
CAUTION							
BURST HAZARD							
Open the service valves before the operation, otherwise there might be the burst.							

IMPORTANT INFORMATION

- **All electrical work should be carried out by a competent person and wiring must be in accordance with the national electrical installation regulations.**
- **Ensure that installation work is done correctly using the information contained in this manual.**
- **Make all connections securely so that any outside forces acting on the cables are not applied to the terminals.**
- **Never modify or repair by yourself.**
Any attempt to do so will void the warranty.
- **To dispose of this product, consult your dealer.**

WARNING

1. **Using the specified wires, ensure to connect the wires, and fix wires securely so that the external tension to the wires do not affect the connecting part of the terminals.**
Incomplete connection or fixation may cause a fire, etc.
2. **Be sure to connect earth wire. (grounding work)**
Incomplete grounding cause an electric shock. Do not connect ground wires to gas pipes, water pipes, lightning rods or ground wires for telephone wires.
3. **Appliance shall be installed in accordance with national wiring regulations.**
Capacity shortage of power circuit or incomplete installation may cause an electric shock or a fire.

CAUTION

- If incorrect/incomplete wiring is carried out, it will cause an electrical fire or smoke.
- Be sure to install an earth leakage breaker that is not tripped by shock waves.
If an earth leakage breaker is not installed, an electric shock may be caused.
- Be sure to use the cord clamps attached to the product.
- Do not damage or scratch the conductive core and inner insulator of power and inter-connecting wires when peeling them.
- Use the power cord and Inter-connecting wire of specified thickness, type, and protective devices required.
- Never connect 220-240V power to the terminal blocks (A , B , U1/U2, U3/U4 etc.) for control wiring (Otherwise, the system will fail).

REQUIREMENT

- For power supply wiring, strictly conform to the Local Regulation in each country.
- For wiring of power supply of the outdoor units, follow the Installation Manual of each outdoor unit.
- Perform the electric wiring so that it does not come to contact with the high-temperature part of the pipe. The coating may melt resulting in an accident.
- After connecting wires to the terminal blocks, provide a trap and fix wires with the cord clamp.
- Run the refrigerant piping line and control wiring line in the same line.
- Do not turn on the power of the indoor unit until vacuuming of the refrigerant pipes completes.

■ **Power supply wire and communication wires specifications**

Power supply wire and communication wires are procured locally.

For the power supply specifications, follow to the table below. If capacity is little, it is dangerous because overheat or seizure may be caused. For specifications of the power capacity of the outdoor unit and the power supply wires, refer to the Installation Manual attached to the outdoor unit.

Indoor unit power supply

- For the power supply of the indoor unit, prepare the exclusive power supply separated from that of the outdoor unit.
- Arrange the power supply, earth leakage breaker, and main switch of the indoor unit connected to the same outdoor unit so that they are commonly used.
- Power supply wire specification : Cable 3-core 2.5mm², **in conformity with Design 60245 IEC 57.**

▼ Power supply

Power supply	220-240V —, 50Hz	
Power supply switch/Earth leakage breaker or power supply wiring/fuse rating for indoor units should be selected by the accumulated total current values of the indoor units.		
Power supply wiring	Below 50m	2.5 mm ²

Control wiring, Central controller wiring

- 2-core with polarity wires are used for the Control wiring between indoor unit and outdoor unit and Central controller wiring.
- To prevent noise trouble, use 2-core shield wire,
- The length of the communication line means the total length of the inter-unit wire length between indoor and outdoor units added with the central control system wire length

1. Product Overview



Description

Our latest generation Toshiba SMART Touch Controller provides a modern compact approach to management control technology utilising easy to use Icons and simple intuitive navigation to deliver sophisticated strategies that provide precise control and data analysis.

The Toshiba SMART Touch Controller is simple to install and configure and offers three levels of operation, general user, building manager and engineering, all password protectable. The Toshiba SMART Touch controller features a built-in web browser interface, air conditioning status, unit enable and disable, time and alarm management control and fault indication.

Features

- § Built in Web Browser
- § Customisable appearance
- § Alarm Settings
- § Unit setup, status and inhibit
- § Programmable time and date events
- § Maximum 64 Indoor Units/Groups and 16 Outdoor systems can be connected
- § TCB-PCNT30TLE2 Network adaptor required for connection of DI/SDI to provide TCC Link Connection

MAIN FUNCTIONS

FUNCTION	COMMAND INPUT	STATUS OUTPUT
ON/OFF Status	✓	✓
Operation Mode	Auto, Heat, Cool, Dry, Fan Only	✓
Fan Speed	Stop, Auto, Ultra-low, Low, Medium, High	✓
Louver	Horizontal, Vertical, Swing	✓
Set Temperature	18-29°C	✓
Room Temperature	✓	✓
Permit/Prohibit of Local Operation	ON/OFF, Mode, Set temp, fan speed, louver	✓
Error Status	Reset	✓
Error Code	Reset	✓

Limits

The device is limited to standard network restrictions applied to the TCC- link network with a maximum indoor unit count of 64 indoor units.

SPECIFICATION

Chassis material	Aluminium / Steel
Power Supply	230V AC 5VA
Number of Connectable Indoor Units	64
Operating Temperature / Humidity	0 to 40°C / 10 to 90%
Storage Temperature	-20 to 60°C (no condensation)
Dimensions H X W X D	120 x 200 x 40 mm
Communications Platforms	USB 2.0, RS485, 2-wire Network Bus and Network Connection
Graphic Display	7" Capacitive SMART Touch Screen
Air Conditioner Connection TCC Link	2-wire U3 / U4 communication bus
Digital signals	4x Digital input , 4x relay output

2. Connection Details

All electrical work should be carried out by a competent person and wiring must be in accordance with the national electrical installation regulations.

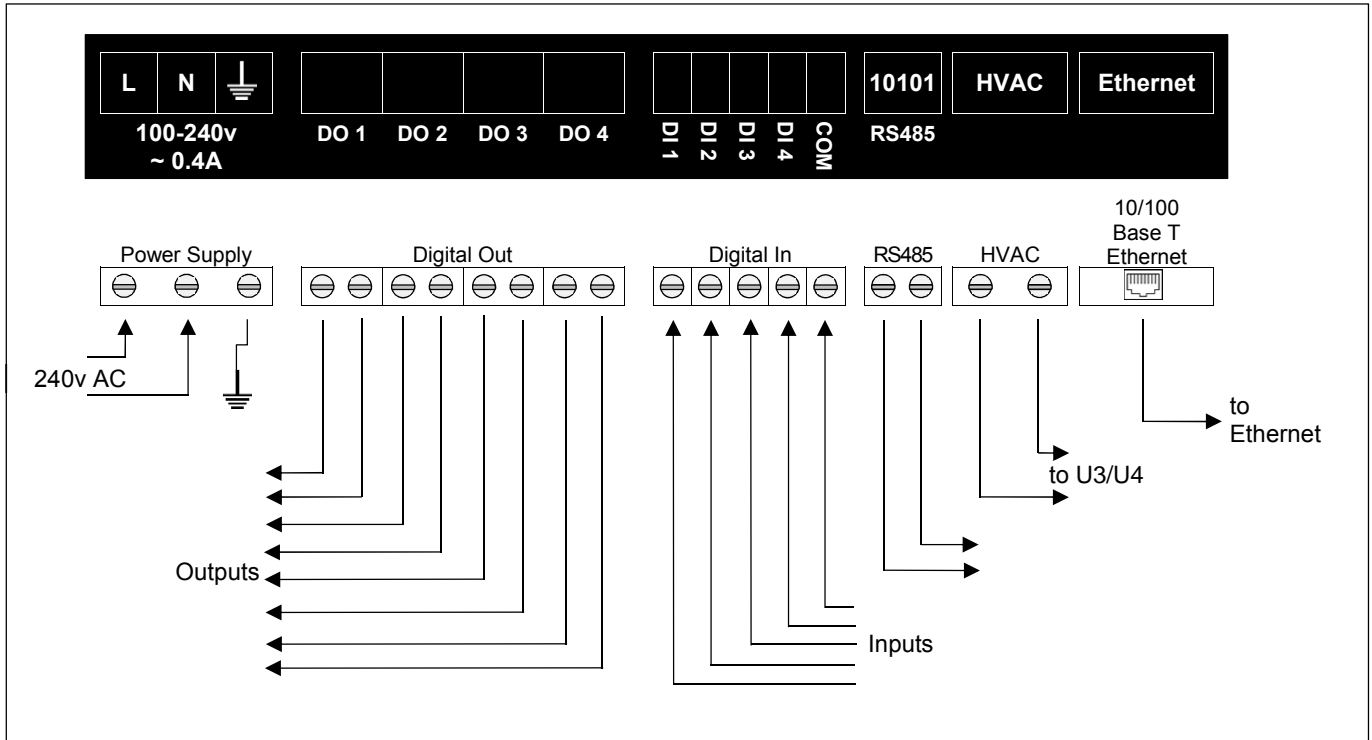

NO.	LINE	DESCRIPTION	
1	For TCC-LINK	Type	2-core shield wires
		Wire size and max. length	1.5 mm ² 1000m max. (min. 1.25 mm ²) 2.5 mm ² 2000m max. (min. 2.00 mm ²) (total length including air conditioner area)
2	For RS-485	Type	2-core shield wires (dedicated cable or equivalent)
		Wire size and max. length	1.5 mm ² 500m max. (min. 1.25 mm ²) (total length)
3	For Power	Type	H07 RN-F or 245IEC66
		Wire size	0.75mm ² , 50 m max.

2.1. Power Supply

The SMART Touch Controller requires a 240v 3 amps AC supply and has a consumption not exceeding 5VA.

THIS EQUIPMENT MUST BE EARTHED

2.2 HVAC Communications Network (TCC-LINK)

Connect to outdoor unit terminals U3 and U4, as per a standard central controller. These are non-polarized.

2.3. Digital Input / Output

The digital input and output currently have no functionality.

2.3.1. Digital Inputs

- 1 Global disable : when active, turns all units off and inhibits the remote controllers.
: on becoming inactive, removes the inhibits from the remote controllers only.
- 2 Global on : on becoming active, turns all units ON.
: on becoming inactive, turns all units OFF.
- 3 Not assigned
- 4 Not assigned

2.3.2. Digital Outputs

- 1 Any unit in alarm : active when any unit present on the system returns an error code.
- 2 Any unit on : active when any unit on the system returns an 'ON' state.
- 3 Not assigned
- 4 Not assigned

Digital input 1 is permanently enabled and active 'open'.

All other inputs and outputs have an enable switch and a polarity selector.

Relay ratings are 24v @ 1amp

2.4. USB

The USB interface located behind the cover plate is used for configuration via a PC and for upgrading the firmware.

Ensure that the correct USB driver has been installed prior to connecting the SMART Touch Controller to a PC.

2.5. Ethernet

The SMART Touch Controller is a 10/100Base-T half/full duplex device. It supports auto-negotiation and also features auto-crossover (Auto-MDIX), allowing the use of either a straight-through or crossover cable.

It does not currently support DHCP and will therefore require the IP address, gateway address and subnet-mask configuring to match the host network it is attached to.

If the unit is only being accessed via the local network then set the gateway address to be

the same as the IP address, otherwise enter the address of the appropriate gateway or router.

2.6. Firmware Updates ***** IMPORTANT NOTICE *****

Please check our website on a regular basis to update controller software

3. Air Conditioner Address Configuration

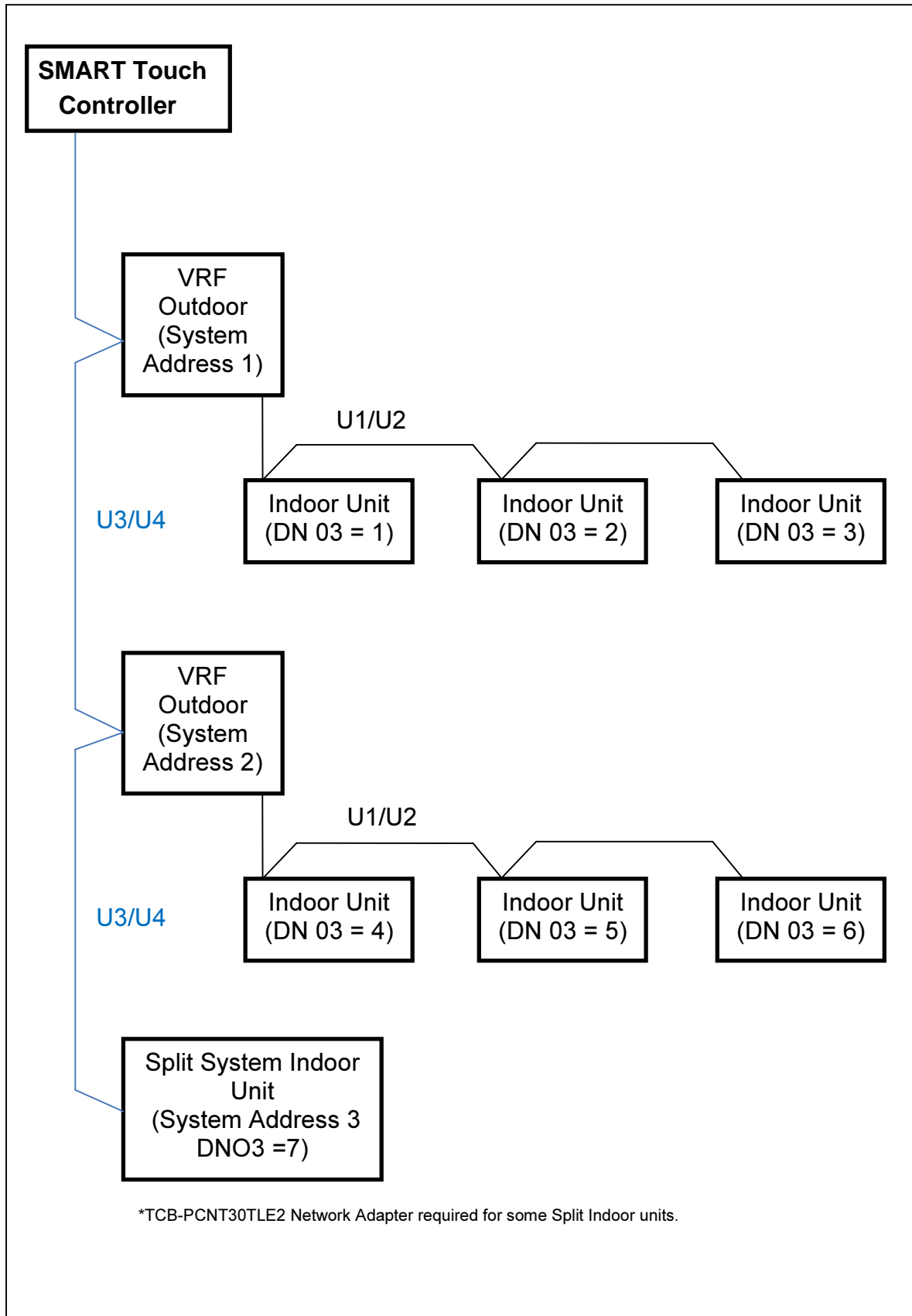

Systems need to be set-up in the same way that a standard Toshiba central controller is used. The SMART Touch can replace or work in parallel with other TCC-Net devices. Each refrigerant system must have a separate line address and the network address (Configuration Item 03) must be set between 1 and 64. If units are grouped via A+B connection the units will have the same network address and the status data for the follower units will not be available.

Units can be grouped within the SMART Touch using the HVAC configuration option. The group number is defined as 'the lowest indoor unit address within the group'. This becomes the 'Header' address for the group, and is the only address within that group that can accept commands.

Other units within a group are classed as 'follower' units and contain the same status parameter values as the 'Master' apart from Return Air Temperature and Error Code which are unique to each unit.

Attempting to write a command to a 'slave' unit will have no effect.

To monitor slave units within a group, ensure they are configured as individual units (via the A/C system) and grouped using the SMART Touch.

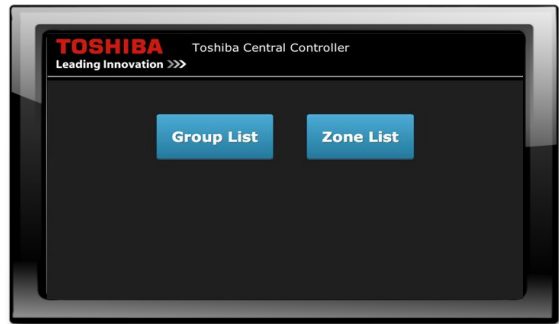

4. Dimensions

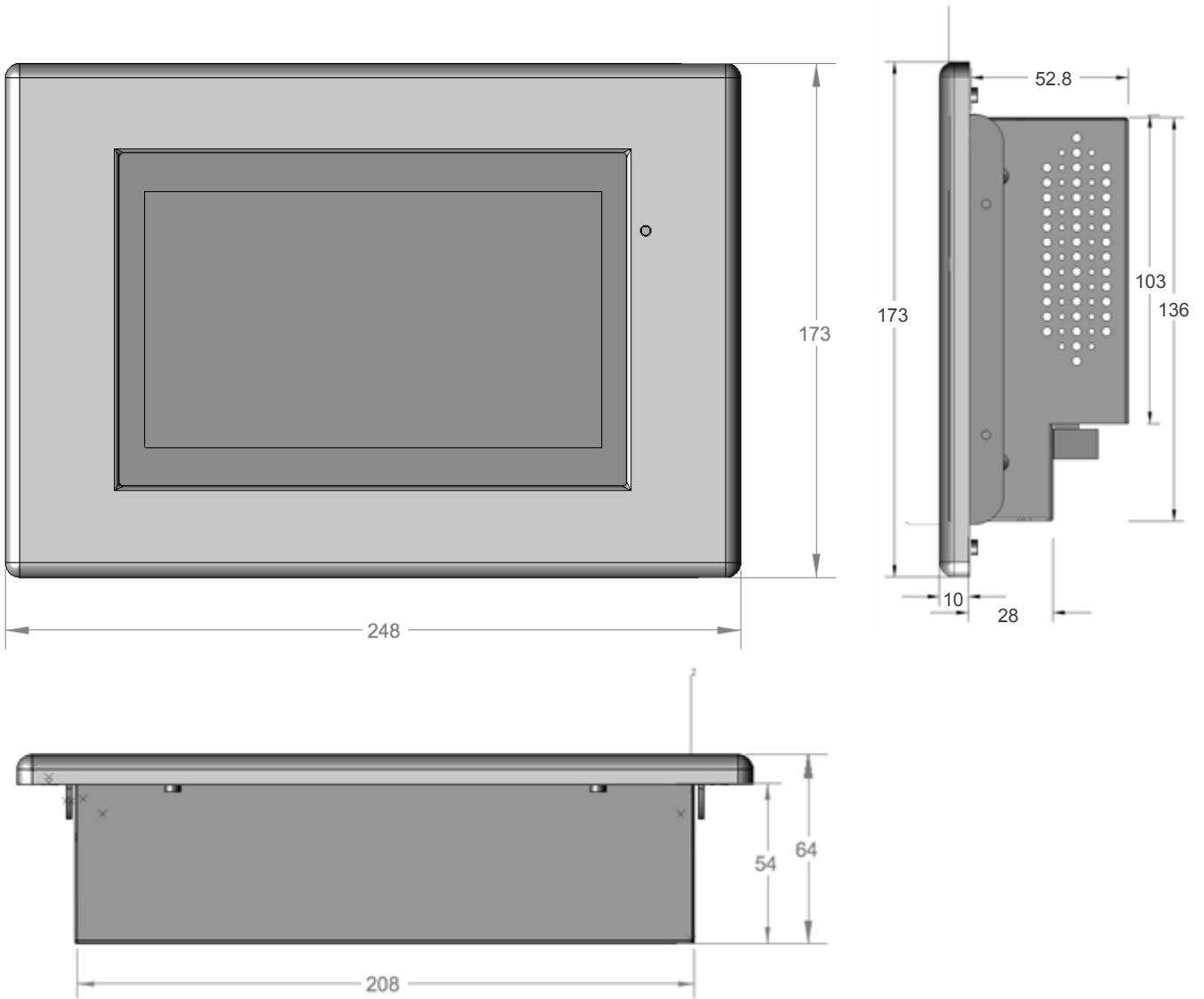

Fixing Frame

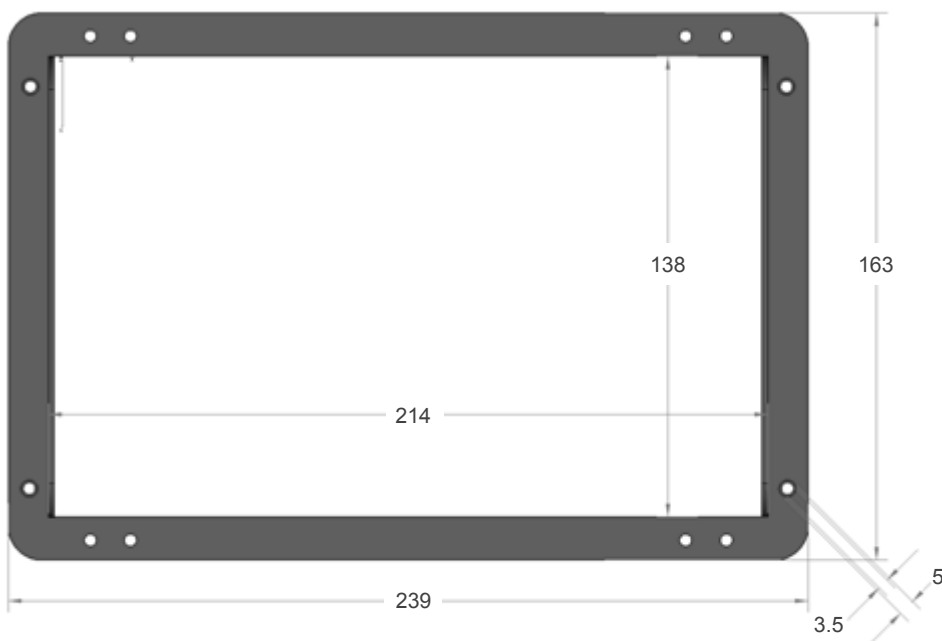

5. User Interface

5.1. Start-Up



The controller can take several minutes to discover the connected units on the network.

5.2. SMART Touch View options

5.3. Grid view

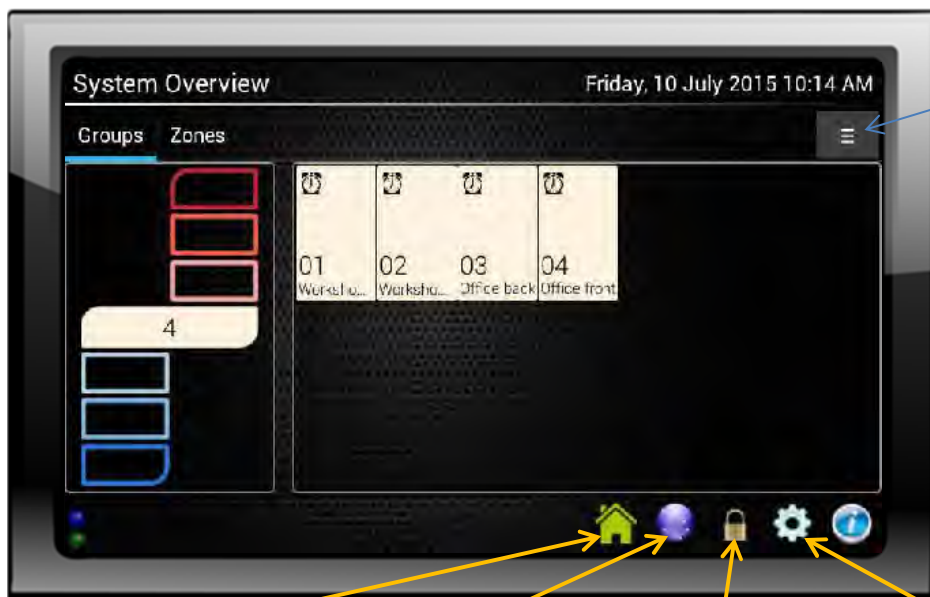

- View Select
- Icon
- List
- Grid
- Global

Home
This button always takes you to the home screen

Network
This indicates connection to a LAN

Security
For later use

Settings
This icon takes you to the settings page

5.4. List View



The list view provides a setting snap shot of the connected units. This can be scrolled up and down to find the required unit. Unit operation can be adjusted by selecting a Unit

5.5. Icon



The Icon view provides a visual unit indication. This can be scrolled up and down to find the required unit. Unit operation can be adjusted by selecting a Unit

5.6. Global Control



The global control view allows the same settings to be sent to all indoor units

5.7. Unit Control



The indoor unit settings can be changed by selecting the unit at which point the above will be displayed. The unit settings can be updated

5.8. Configuration



The configuration page allows you to access the controller setup options from unit grouping to schedule configuration

5.9. Network Setting



The network item allows the IP address to be set for the remote access via the Web browser

5.10. Time setting



The date and time are set under the time option

5.11. Group / Zone Configuration



To create new Zone or Group and select Configure Groups or Configure Zones from the drop down menu

Groups and zones are configured under HVAC Configuration. This allows units to be set as individual units or grouped together

To add units to a new Zone or Group select the units they turn red. Then select create new group or Zone. Individual or header units appear Green. Follower units appear blue



To deselect go to that option and select the units turn red. The selected units can then be added to the groups or Zones

5.12. Schedule Setup

The schedule set up process is as follows.

1. Set up a daily schedule
2. Add the daily schedule to the weekly schedule
3. Attach the schedule to a group of units

1. Set up a daily schedule

To set up a daily schedule select Daily

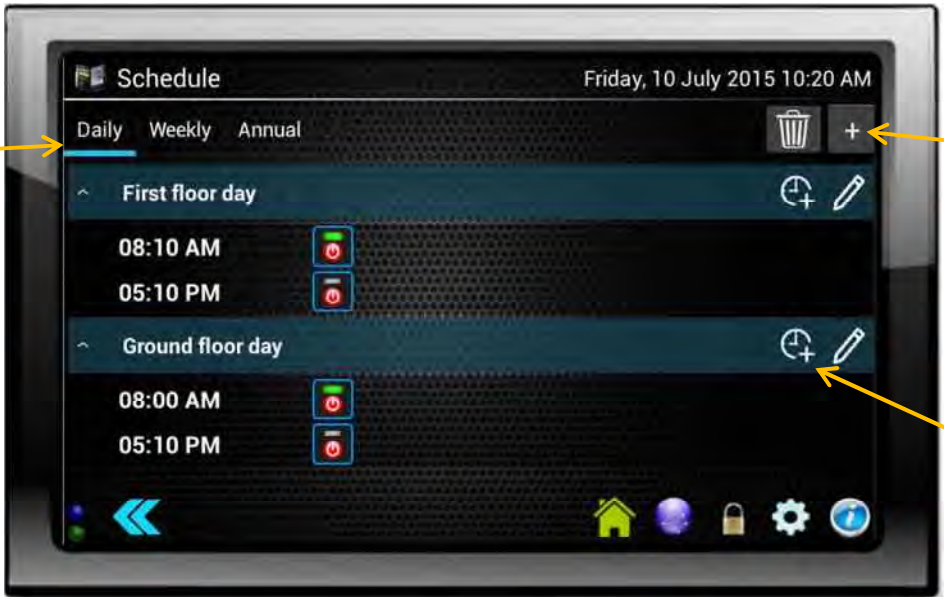

Select "+" this will create a schedule add a name *example* "First floor day"

Select the "Timer +" this will add an event



Select the time you wish the operation to happen

Select the item you wish to set by sliding the switch above the item and select the value

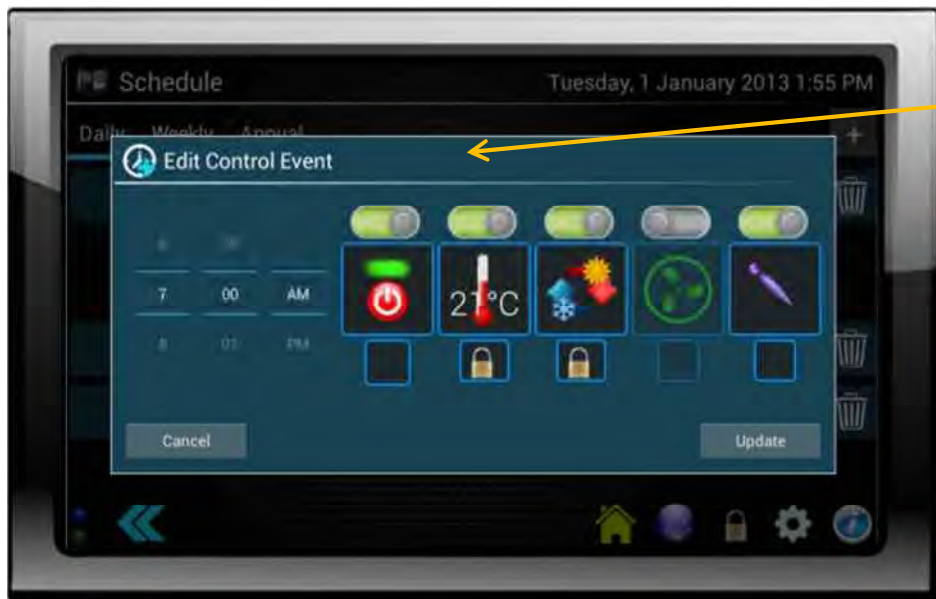

An event can be modified by selecting the event and changing the required value

2. Add the daily schedule to the weekly schedule



To set up a Weekly schedule select Weekly

Select "+" this will create a Week add a name "First floor week"

Select the "Calendar +" this will open the window below

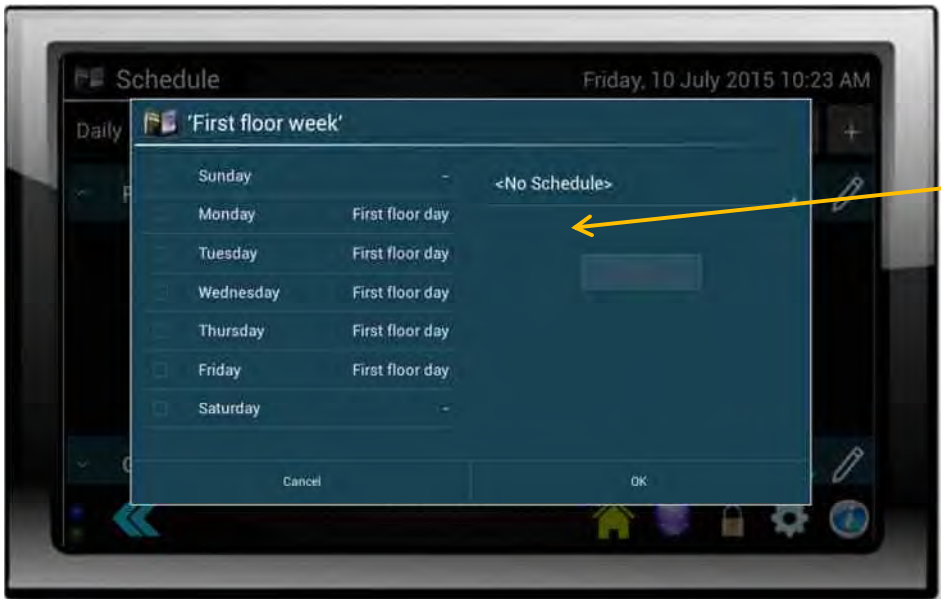

Select the day and you are able to choose the daily schedule to add

3. Attach the schedule to a group of units

In the HVAC Configuration select Groups. Then find the group you wish to attach the schedule to and select. The screen below will then appear



You now have the option to attach the schedule. Either a primary schedule for everyday use or a secondary schedule for special days can be selected

5.13. System Logs



The Log Viewer provides a record of system events. It can be cleared by selecting the x

6.0 Version History and New Features Guide

6.1. Version Information

- v1.02.02 - initial release
- v1.03.01 - setting the setpoint limits for a group now works correctly
- added various digital input & output functions
- v1.03.02 - setting the setpoint on a daily schedule now works correctly
- fixed crashing caused by deleting all daily or weekly schedules
- v1.04.01  - enabled 'Security' in config menu
 - ↳ users can be defined with 1 of 3 different security levels
 - bug fix: zones can now be deleted
 - enabled 'General Settings' in config menu
 - ↳ controller can now be named (name is displayed on System Overview screen)
 - various screen layout updates
- v1.04.02  - enabled 'secondary scheduling' feature
 - added ability to hide 'ungrouped' units
 - ↳ this is useful when multiple SMART touch controllers are connected to the same TCC-Link, and each controller must only see a subset of the HVAC
 - added 'Controller Address' setting, if multiple controllers are present
 - added support for VN heat-exchangers
 - ↳ only available if Black Pear HVAC controller firmware is at least v2.23
 - ↳ not fully supported on web pages yet (mode states do not display correctly)
- v1.04.03 - various minor screen layout changes
- removed various unused bitmaps
- v1.04.04 - schedule control points can now set temperature setpoint down to 10°C
- Black Pear HVAC controller firmware can now be updated
- v1.05.01  - Annual scheduling is now working
 - German language can now be selected
 - Backup & Restore functions have been added
 - ↳ allows all configuration settings, HVAC setup and schedules to be backed up to a USB stick
- v1.05.02 - minor bug fixes
- v1.05.03 - bug fix: HVAC Group Configuration
 - attempting to add a unit to a group when no valid groups are available (ie the unit address is lower than any defined group number), caused a crash.
- v1.05.04 - bug fix: setpoints changed via remote controllers did not adhere to group setpoint range
 - includes Black Pear HVAC controller firmware v2.28

 New features added. Further details are described in this document.

6.2. v1.04.01 Update Details

- 1) Security (can be globally enabled or disabled)
 - a) Added 3 levels of security.
 - b) Password protection of manual HVAC control (enable/disable)
 - a user (any level) must be logged in to make any changes.
 - c) Auto logout when the screen is dimmed (enable/disable)

See description on following pages.

- 2) General Settings
 - a) Allows controller to be named (displayed on System Overview screen).
 - b) The name will default to 'STC-xxxxxxxxxxxx'
 - where xxxxxxxxxxxx is the MAC address of the controller.
- 3) Zone updates
 - a) Zones can now be deleted.
 - b) Zone control has been fixed.
- 4) Various screen layout changes.



6.3. Security Features

Security has been added to be able to limit the accessibility of certain features. Should these features not be required then security can be globally disabled.

Note:

The security features currently do not apply when accessing the controller via a web browser.



There are 3 levels of security:

Icon	Security Level	Description
	Engineer	Unrestricted access: Access to all configuration features. Access to all manual HVAC controls. Add and delete users with any security level.
	Building Manager	Partially restricted access: Access to all configuration features apart from: Allocating units to groups. Allocating groups to zones. Access to all manual HVAC controls. Add and delete users up to 'Building Manager' level. No access to global security settings.
	User	Limited access: Access to 'Appearance' configuration only. Access to manual HVAC controls apart from: Remote controller inhibit. Unable to acknowledge alarms and delete logs. Unable to upgrade system.

A default 'engineer level' user is created, the first time the SMART Touch controller is started with security features available. The user name is 'engineer' and the password is '0000'.

Please ensure that there is at least 1 'engineer level' user defined when security is enabled.

6.4. Security Status Indicators

Icon	Description
	Security is enabled. Clicking this icon will bring up the login window.
	Security is enabled and someone has logged in successfully. Clicking this icon will bring up the logout window.
	Manual control of the HVAC is password protected. To make adjustments, a user (any security level) must be logged in. This icon is displayed on the System Overview screen.

6.5. Security Configuration Screen

Displays the users listed under their defined security level, and also provides access to the global security settings.



6.6. Security Settings

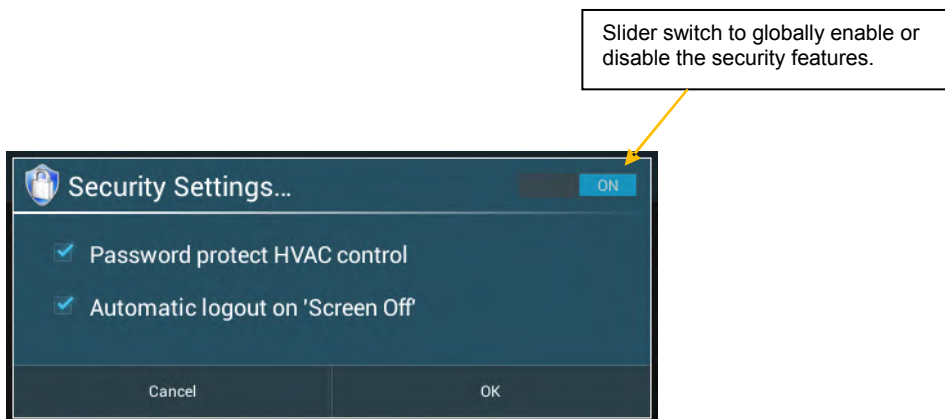

Setting	Description
Password protect HVAC control	When enabled, all manual control of the HVAC system is disabled until a user (with any security level) logs in.
Automatic logout on 'Screen Off'	When enabled, will automatically log a user out when the controller turns the screen off.

6.7. v1.04.02 Update Details

1) HVAC settings

- a) ability to hide 'ungrouped' units.
- b) controller address is now settable

See description on following pages.

2) Scheduler settings

- a) enabled 'secondary scheduling' feature
 - a global date range is used to determine when the secondary schedule is active.

See description on following pages.

3) VN heat-exchanger support (only when Black Pear HVAC ctrl firmware \geq v2.23)

- a) when a group or zone is defined as a heat-exchanger then the manual control screen will only give access to on/off, mode and fanspeed.

6.8. HVAC Settings

Clicking this button displays the 'HVAC Settings' window.

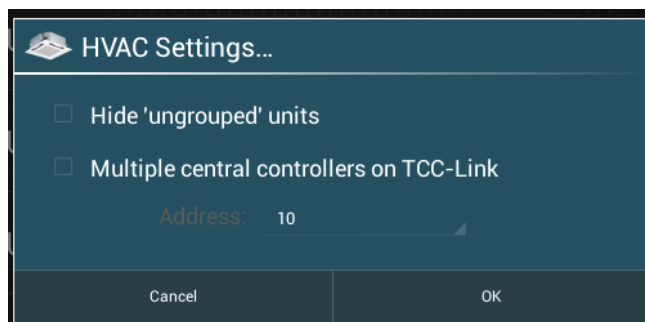
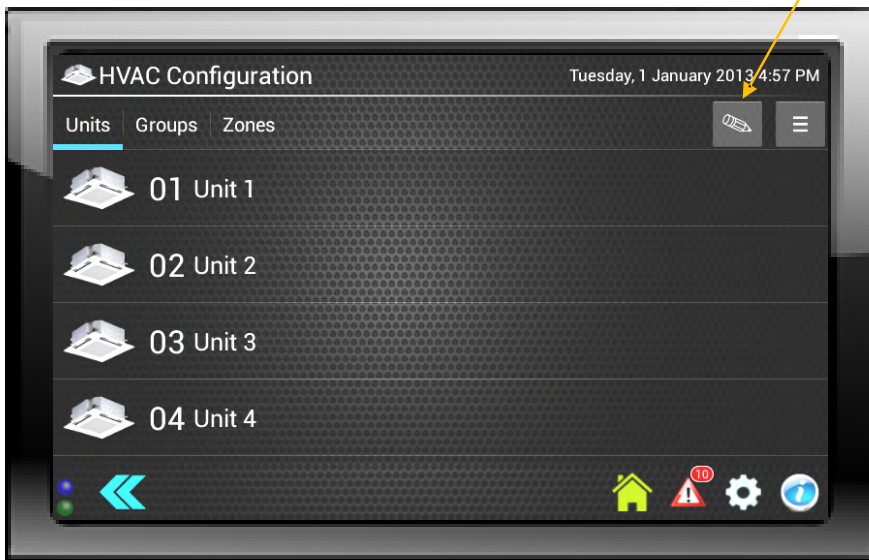

Setting	Description
Hide 'ungrouped' units	Allows multiple SMART Touch controllers to be connected to the same TCC-Link, with each controller only seeing a subset of the HVAC system. Any active unit that hasn't been added to a group will not be displayed.
Multiple central controllers on TCC-Link	Tick to enable address setting.
Address	Enabled when 'Multiple central controllers...' is ticked. Settable from 1 to 10

6.9. Scheduler Settings

Clicking this button displays the 'Scheduler Settings' window.

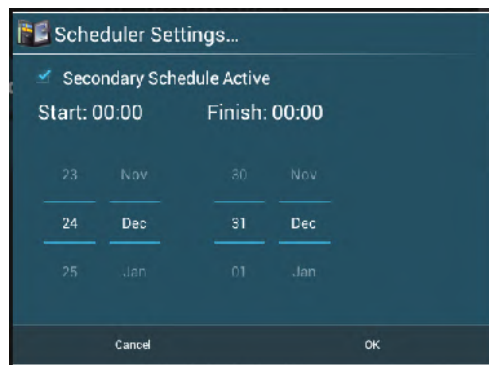
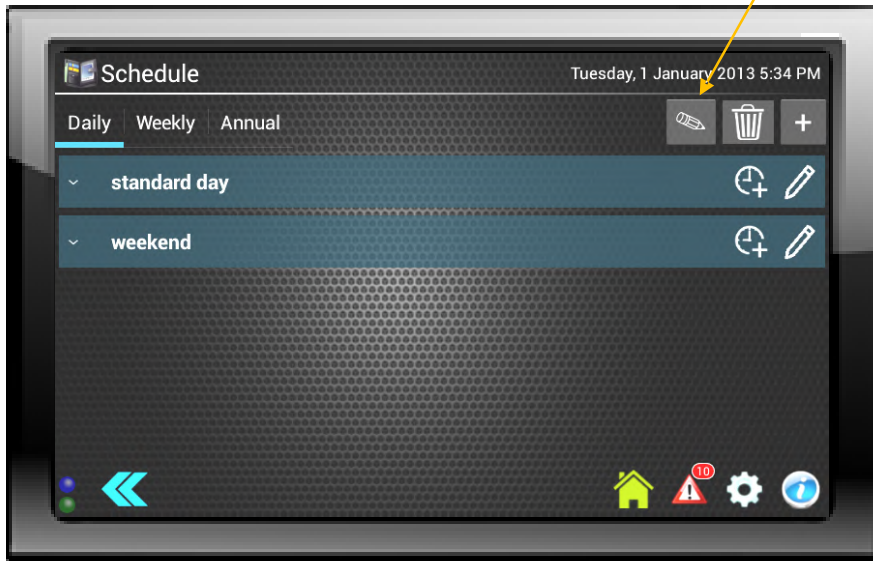

Setting	Description
Secondary Schedule Active	Enables the secondary scheduling feature. If a group doesn't have a secondary schedule defined, then the primary schedule will be used.
Start Date	The secondary schedule will start at 00:00 on the date selected.
Finish Date	The secondary schedule will finish at 00:00 on the date selected.

6.10. v1.05.01 Update Details

1) Scheduler

- Annual scheduling is now available.

See description on following pages.

2) Enabled 'Language' icon on Configuration Menu

- Added german language translations.

3) Enabled Backup and Restore feature

See description on following pages.

6.11. Annual Schedules

Overview:

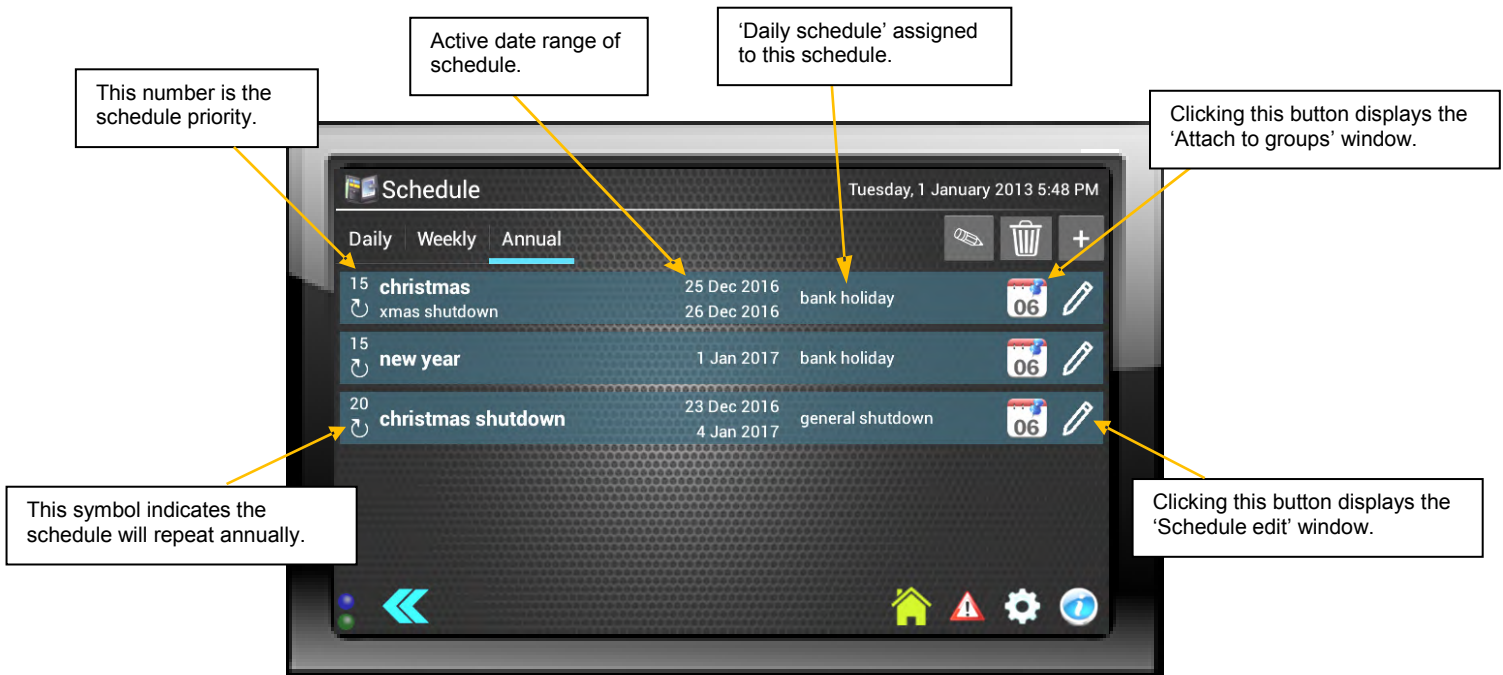

- Annual scheduling allows actions to occur on a specific date or range of dates.
- Annual schedules take precedence over the standard weekly schedules.
- Each day will perform the same specified daily schedule.
- A schedule can be a 'one-shot' event or can repeat annually.
- Schedule priority allows multiple schedules to overlap, with the highest priority 'active' schedule taking precedence.

6.12. Creating and Editing a Schedule

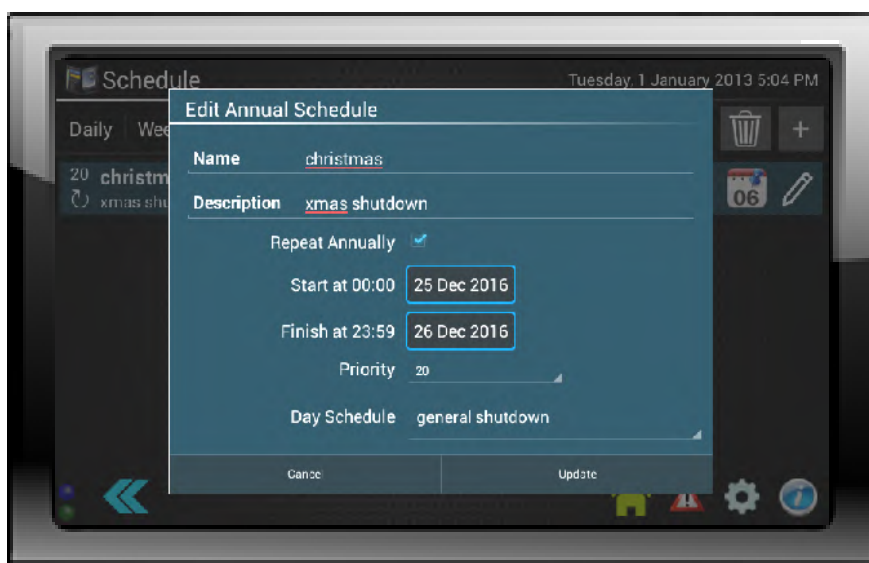

Setting	Description
Name	Schedule identifier
Description	Additional details (if required).
Repeat Annually	Selects whether schedule is a 'one-shot' event or annual event.
Start at 00:00	Start date of schedule.
Finish at 23:59	Finish date of schedule. If the same as the start date then the schedule is active for 1 day only.
Priority	Used to organise overlapping schedules. Selectable from 1 to 20, where 1 is the highest priority. Schedules with the same priority will be ordered alphabetically.
Day Schedule	Scheduled actions to be performed.

6.13. Assigning Groups to an Annual Schedule

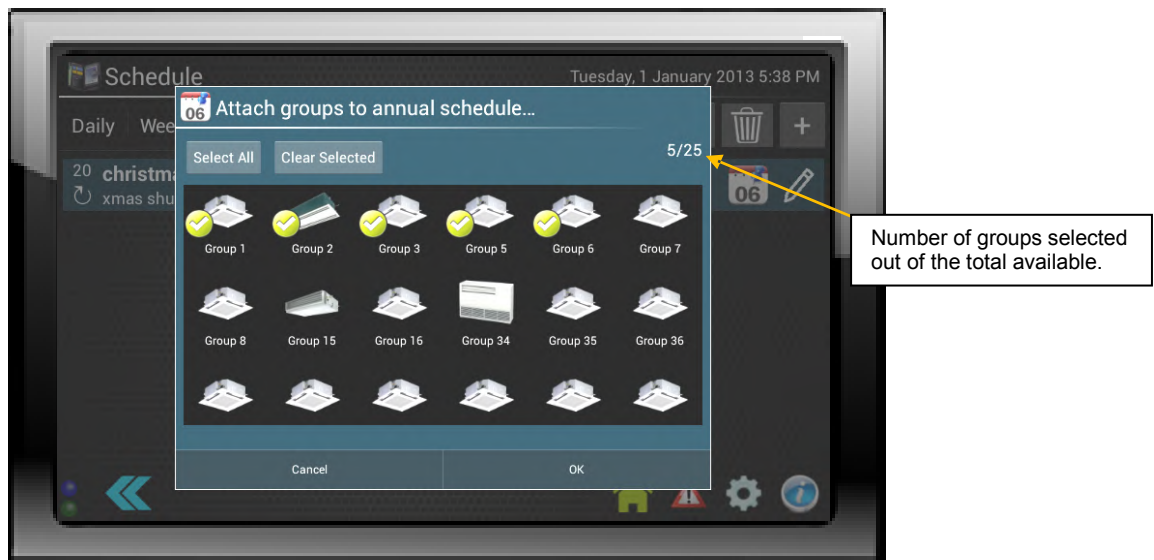

Tapping a group icon will toggle the tick mark. Any group showing the tick mark will be controlled by the annual schedule when it becomes active.

Groups can be assigned to multiple annual schedules. Where schedules overlap, then the priority determines which will take precedence.

Note: Any weekly schedules assigned to these groups will be overridden while the annual schedule is active.

6.14. Backup and Restore

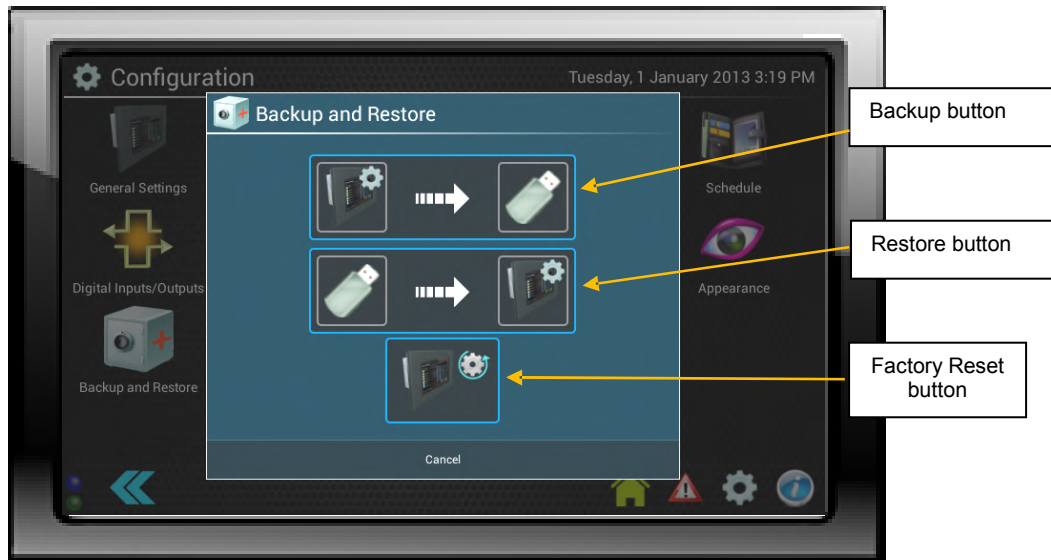

6.15. Backup Current Configuration

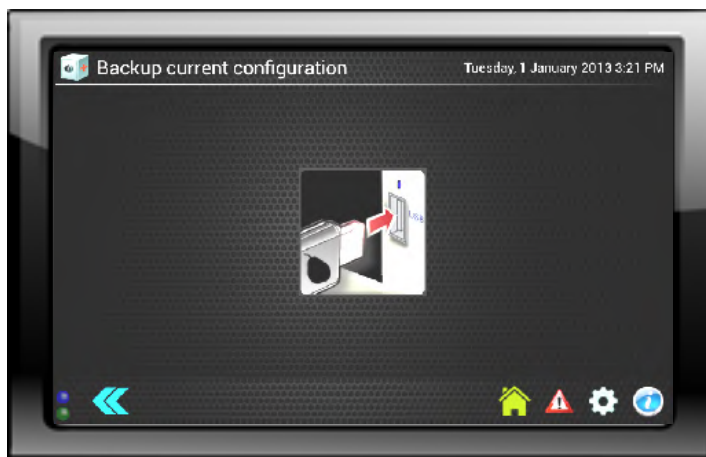

If this screen appears then insert a USB memory stick.

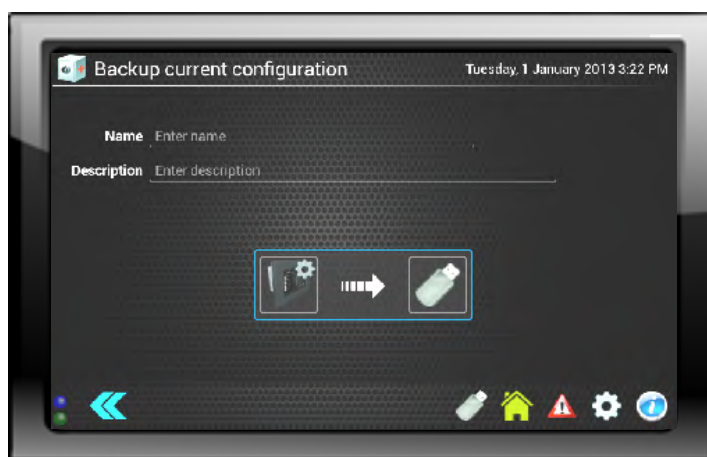

'Name' must be a valid filename.
' .zip' will automatically be appended to this name.

The backup creates a 'zip folder' containing all the settings, unit/group/zone information, scheduling, user information etc.

The name, description, date/time, the user performing the backup (if logged on) and the software version of the Smart Touch controller, are also stored, and are used to identify the backup during the restore process.

The backup will be stored in the 'root' directory of the USB memory stick.

6.16. Restore from Backup

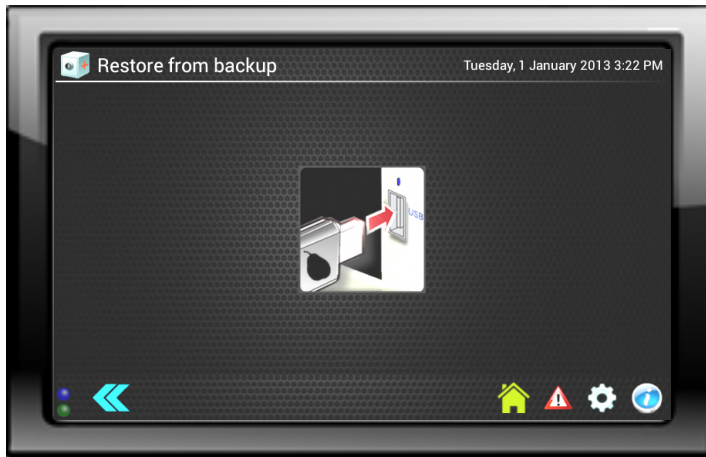

If this screen appears then insert a USB memory stick.

Name and description Date and time backup was created User who created the backup (if logged in)

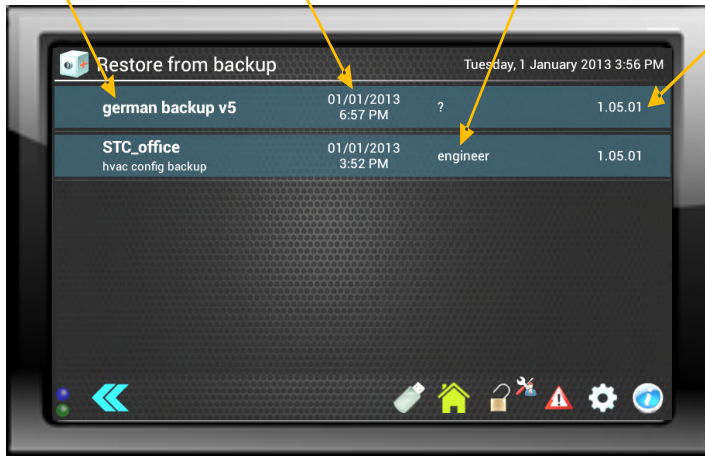

SMART Touch controller software version, when backup was created

The 'root' directory of the USB memory stick will be scanned, and all available backups will be listed.

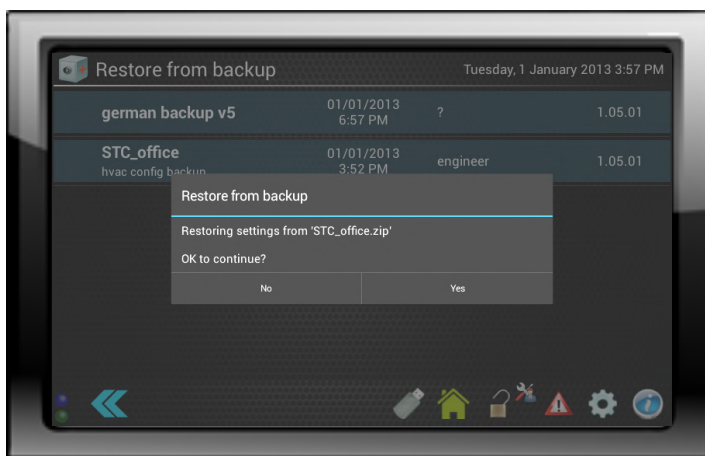

Clicking on an available backup will start the restore process. Provided the backup contains no errors and was not created on a more recent version of the STC software, then the restore process will continue and the controller will restart automatically.

7. Connection to an Internet Browser

7.1. Connection

- 1C The controller is connected to the network or a PC via a standard network cable the connection is on the back of the controller (shown in the diagram below labelled Ethernet)

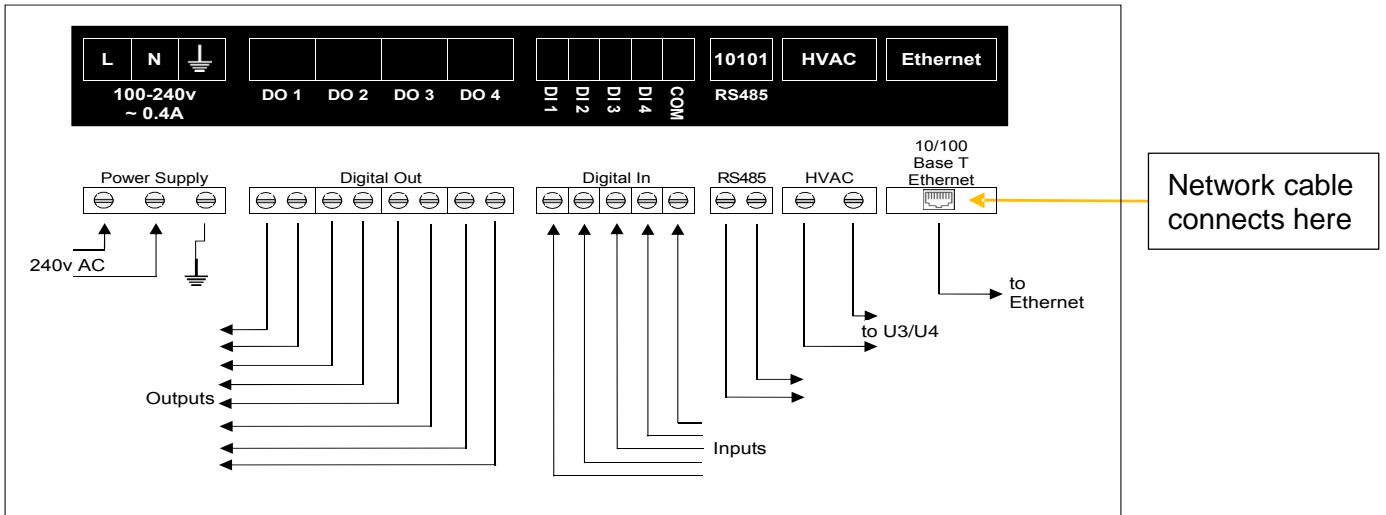

7.1. IP Configuration

The IP address can be configured by opening the network tab contained within the configuration icon on the controller. When the controller is connected to a network this information would be provided by the network administrator.



7.1. Browser Connection

The default or chosen address is inserted into the browser address in the format shown below to show the web page.

For example, if the IP address of the Smart Touch is 192.168.1.10, then type the following into the browser address bar....

192.168.1.10:8080

or

<http://192.168.1.10:8080>

Some browsers require the ' http://' before the address and some don't.

8. Trouble Shooting Error Codes

Error Code	Description
C05	Sending error in TCC-LINK central control device
C06	Receiving error in TCC-LINK central control device
C12	Batch alarm of general-purpose equipment control interface
E01	Communication error between indoor and remote controller (Detected at remote controller side)
E02	Sending error of remote controller
E03	Communication error between indoor and remote controller (Detected at indoor side)
E04	Communication circuit error between indoor and outdoor (Detected at indoor side)
E06	Decrease of No. of indoor units
E07	Communication circuit error between indoor/outdoor (Detected at outdoor side)
E08	Duplicated indoor addresses
E09	Duplicated master remote controllers
E10	Communication error between indoor PCB
E12	Automatic address start error
E15	No indoor automatic address
E16	Capacity over / No. of connected indoor units
E18	Communication error between indoor header and follower units
E19	Outdoor header units quantity error
E20	Other line connected during automatic address
E23	Sending error in communication between outdoor units
E25	Duplicated follower outdoor address
E26	Decrease of No. of connected outdoor units
E28	Follower outdoor unit error
E31	IPDU communication error
F01	Indoor TCJ sensor error
F02	Indoor TC2 sensor error
F03	Indoor TC1 sensor error
F04	TD1 sensor error
F05	TD2 sensor error
F06	TE1 sensor error
F07	TL sensor error
F08	TO sensor error
F10	TA sensor error
F12	TS1 sensor error
F13	TH sensor error
F15	Outdoor temp. sensor misconnection (TE1,TL)
F16	Outdoor pressure sensor misconnection (Pd,Ps)
F23	Ps sensor error
F24	Pd sensor error
F29	Indoor other error
F31	Outdoor EEPROM error
H01	Compressor break down
H02	Magnet switch error / Overcurrent relay operation / Compressor error (lock)
H03	Current detection circuit error
H04	Comp-1 case thermo operation
H06	Low pressure protective operation
H07	Low oil level protection
H08	Oil level temp. sensor error
H14	Comp-2 case thermo operation
H16	Oil level detection circuit error / Magnet switch error / Overcurrent relay error

Error Code	Description
L03	Duplicated indoor header units
L04	Duplicated outdoor line address
L05	Duplicated indoor units with priority (Displayed in indoor unit with priority)
L06	Duplicated indoor units with priority (Displayed in unit other than indoor unit with priority)
L07	Group line in individual indoor unit
L08	Indoor group/Address unset
L09	Indoor capacity unset
L10	Outdoor capacity unset
L20	Duplicated central control addresses
L28	Maximum number of outdoor units exceeded
L29	No. of IPDU error
L30	Auxiliary interlock in indoor unit
L31	IC error
P01	Indoor fan motor error
P03	Discharge temp. TD1 error
P04	High-pressure switch detection error
P05	Phase-missing detection / Phase order error
P07	Heat sink overheat error
P10	Indoor overflow error
P12	Indoor fan motor error
P13	Outdoor liquid back detection error
P15	Gas leak detection
P17	Discharge temp. TD2 error
P19	4-way valve inverse error,
P20	High-pressure inverse error
P22	Outdoor fan IPDU error
P26	G-Tr short circuit protection error
P29	Comp position detection circuit error
P31	Follower indoor unit error (Group error)

Note: For further information regarding the above error codes, please contact your local Toshiba A/C supplier, or Toshiba A/C technical support.

Note: Toshiba Carrier UK Limited reserves the right to change specification without notice.

TOSHIBA Leading Innovation >>>

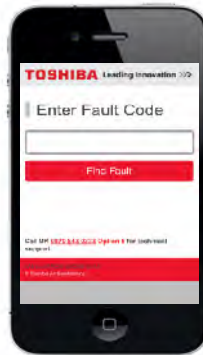

Fault code diagnosis apps now available
For
Apple iPhone & Android



24 Hour Technical Helpline: **0870 843 0333**

Fault & DN Code Apps: Android & iPhone Web Page

toshiba-calc.co.uk/fault-codes/

Fault Code Text Service: **07624 803 017**

technical.enquiries@toshiba-ac.com

Technical Department

TOSHIBA

AIR CONDITIONING

A division of Toshiba Carrier UK Limited

Parkfield House, Manchester Old Road, Middleton, Manchester, M24 4DY

www.toshiba-aircon.co.uk

Tel: 44 (0) 870 843 0333 Fax: 44 (0) 161 654 4476

UK Headquarters

Toshiba Carrier UK Limited
United Technologies House,
Guildford Road,
Leatherhead,
Surrey
KT22 9UT

Tel: 01372 220240

Fax: 01372 220241

marketing.uk@toshiba-ac.com

Plymouth

Toshiba Carrier UK Limited
Porsham Close,
Belliver Industrial Estate,
Plymouth,
Devon
PL6 7DB

Tel: 0870 843 0333

Fax: 01752 784574

toshiba.salesdesk.uk@toshiba-ac.com