

Split Case Outdoor Unit

SMMS_e



SHRM_e



Original instruction

ADOPTION OF NEW REFRIGERANT

This Air Conditioner uses R410A an environmentally friendly refrigerant.

Contents

1	Precautions for safety	5
2	Installation of new refrigerant air conditioner	8
3	Selection of installation place	9
4	Refrigerant piping	9
5	Electric wiring.....	13
6	Reassembly Instructions for VRF Outdoor Unit	14
7	Exploded Diagram/Parts List for SMMSe.....	18
9	Exploded Diagram/Parts List for SHRMe.....	39

Thank you for purchasing Toshiba air conditioning products.

This Installation Manual describes the installation method of the outdoor unit. For installation of indoor units, follow the Installation Manual supplied with the indoor unit.

Moreover, as this installation manual includes the important articles concerning the "Machinery" Directive (Directive 2006/42/ EC), please read through the manual and make sure you understand it. After installation, give this Installation Manual, the Owner's Manual and the Installation Manual supplied with the indoor unit to the customer and tell the customer to keep them safe.

Prepare an exclusive power source for indoor units, independent to that for outdoor units.

Y-shaped branching joints or a branching header (separately purchased) are required for connecting pipes between indoor and outdoor units. Choose either of them considering the system capacity concerning piping. For installing branching pipes, refer to the installation manual of the Y-shaped branching unit or branching header (separately purchased).

Outdoor connecting branching joints are required for connecting between outdoor units.

Generic Denomination: Air Conditioner

Definition of Qualified Installer or Qualified Service Person

The air conditioner must be installed, maintained, repaired and removed by a qualified installer or qualified service person. When any of these jobs is to be done, ask a qualified installer or qualified service person to do them for you.

A qualified installer or qualified service person is an agent who has the qualifications and knowledge described in the table below.

Agent	Qualifications and knowledge which the agent must have
Qualified installer	<ul style="list-style-type: none"> • The qualified installer is a person who installs, maintains, relocates and removes the air conditioners made by Toshiba Carrier Corporation. He or she has been trained to install, maintain, relocate and remove the air conditioners made by Toshiba Carrier Corporation or, alternatively, he or she has been instructed in such operations by an individual or individuals who have been trained and is thus thoroughly acquainted with the knowledge related to these operations. • The qualified installer who is allowed to do the electrical work involved in installation, relocation and removal has the qualifications pertaining to this electrical work as stipulated by the local laws and regulations, and he or she is a person who has been trained in matters relating to electrical work on the air conditioners made by Toshiba Carrier Corporation or, alternatively, he or she has been instructed in such matters by an individual or individuals who have been trained and is thus thoroughly acquainted with the knowledge related to this work. • The qualified installer who is allowed to do the refrigerant handling and piping work involved in installation, relocation and removal has the qualifications pertaining to this refrigerant handling and piping work as stipulated by the local laws and regulations, and he or she is a person who has been trained in matters relating to refrigerant handling and piping work on the air conditioners made by Toshiba Carrier Corporation or, alternatively, he or she has been instructed in such matters by an individual or individuals who have been trained and is thus thoroughly acquainted with the knowledge related to this work. • The qualified installer who is allowed to work at heights has been trained in matters relating to working at heights with the air conditioners made by Toshiba Carrier Corporation or, alternatively, he or she has been instructed in such matters by an individual or individuals who have been trained and is thus thoroughly acquainted with the knowledge related to this work.
Qualified service person	<ul style="list-style-type: none"> • The qualified service person is a person who installs, repairs, maintains, relocates and removes the air conditioners made by Toshiba Carrier Corporation. He or she has been trained to install, repair, maintain, relocate and remove the air conditioners made by Toshiba Carrier Corporation or, alternatively, he or she has been instructed in such operations by an individual or individuals who have been trained and is thus thoroughly acquainted with the knowledge related to these operations. • The qualified service person who is allowed to do the electrical work involved in installation, repair, relocation and removal has the qualifications pertaining to this electrical work as stipulated by the local laws and regulations, and he or she is a person who has been trained in matters relating to electrical work on the air conditioners made by Toshiba Carrier Corporation or, alternatively, he or she has been instructed in such matters by an individual or individuals who have been trained and is thus thoroughly acquainted with the knowledge related to this work. • The qualified service person who is allowed to do the refrigerant handling and piping work involved in installation, repair, relocation and removal has the qualifications pertaining to this refrigerant handling and piping work as stipulated by the local laws and regulations, and he or she is a person who has been trained in matters relating to refrigerant handling and piping work on the air conditioners made by Toshiba Carrier Corporation or, alternatively, he or she has been instructed in such matters by an individual or individuals who have been trained and is thus thoroughly acquainted with the knowledge related to this work. • The qualified service person who is allowed to work at heights has been trained in matters relating to working at heights with the air conditioners made by Toshiba Carrier Corporation or, alternatively, he or she has been instructed in such matters by an individual or individuals who have been trained and is thus thoroughly acquainted with the knowledge related to this work.

Definition of Protective Gear







When the air conditioner is to be transported, installed, maintained, repaired or removed, wear protective gloves and 'safety' work clothing.

In addition to such normal protective gear, wear the protective gear described below when undertaking the special work detailed in the table below.

Failure to wear the proper protective gear is dangerous because you will be more susceptible to injury, burns, electric shocks and other injuries.

Work undertaken	Protective gear worn
All types of work	Protective gloves 'Safety' working clothing
Electrical-related work	Gloves to provide protection for electricians and from heat Insulating shoes Clothing to provide protection from electric shock
Work done at heights (50 cm or more)	Helmets for use in industry
Transportation of heavy objects	Shoes with additional protective toe cap
Repair of outdoor unit	Gloves to provide protection for electricians and from heat

■ Warning Indications on the Air Conditioner Unit

Warning indication	Description				
 <table border="1" data-bbox="331 779 552 900"> <tr> <td colspan="2">WARNING</td> </tr> <tr> <td colspan="2">ELECTRICAL SHOCK HAZARD Disconnect all remote electric power supplies before servicing.</td> </tr> </table>	WARNING		ELECTRICAL SHOCK HAZARD Disconnect all remote electric power supplies before servicing.		<p>WARNING ELECTRICAL SHOCK HAZARD Disconnect all remote electric power supplies before servicing.</p>
WARNING					
ELECTRICAL SHOCK HAZARD Disconnect all remote electric power supplies before servicing.					
 <table border="1" data-bbox="331 943 552 1064"> <tr> <td colspan="2">WARNING</td> </tr> <tr> <td colspan="2">Moving parts. Do not operate unit with grille removed. Stop the unit before the servicing.</td> </tr> </table>	WARNING		Moving parts. Do not operate unit with grille removed. Stop the unit before the servicing.		<p>WARNING Moving parts. Do not operate unit with grille removed. Stop the unit before the servicing.</p>
WARNING					
Moving parts. Do not operate unit with grille removed. Stop the unit before the servicing.					
 <table border="1" data-bbox="331 1106 552 1227"> <tr> <td colspan="2">CAUTION</td> </tr> <tr> <td colspan="2">High temperature parts. You might get burned when removing this panel.</td> </tr> </table>	CAUTION		High temperature parts. You might get burned when removing this panel.		<p>CAUTION High temperature parts. You might get burned when removing this panel.</p>
CAUTION					
High temperature parts. You might get burned when removing this panel.					
 <table border="1" data-bbox="331 1270 552 1391"> <tr> <td colspan="2">CAUTION</td> </tr> <tr> <td colspan="2">Do not touch the aluminum fins of the unit. Doing so may result in injury.</td> </tr> </table>	CAUTION		Do not touch the aluminum fins of the unit. Doing so may result in injury.		<p>CAUTION Do not touch the aluminium fins of the unit. Doing so may result in injury.</p>
CAUTION					
Do not touch the aluminum fins of the unit. Doing so may result in injury.					
 <table border="1" data-bbox="331 1433 552 1554"> <tr> <td colspan="2">CAUTION</td> </tr> <tr> <td colspan="2">BURST HAZARD Open the service valves before the operation, otherwise there might be the burst.</td> </tr> </table>	CAUTION		BURST HAZARD Open the service valves before the operation, otherwise there might be the burst.		<p>CAUTION BURST HAZARD Open the service valves before the operation; otherwise there might be the burst.</p>
CAUTION					
BURST HAZARD Open the service valves before the operation, otherwise there might be the burst.					
 <table border="1" data-bbox="331 1597 552 1718"> <tr> <td colspan="2">CAUTION</td> </tr> <tr> <td colspan="2">Do not climb onto the fan guard. Doing so may result in injury.</td> </tr> </table>	CAUTION		Do not climb onto the fan guard. Doing so may result in injury.		<p>CAUTION Do not climb onto the fan guard. Doing so may result in injury.</p>
CAUTION					
Do not climb onto the fan guard. Doing so may result in injury.					

1 Precautions for safety

The manufacturer shall not assume any liability for the damage caused by not observing the description of this manual.

WARNING

General

- Before starting to install the air conditioner, read through the Installation Manual carefully, and follow its instructions to install the air conditioner. Otherwise, falling down of the unit may occur, or the unit may cause noise, vibration or water leakage.
- Only a qualified installer (*1) or qualified service person (*1) is allowed to do installation work. If installation is carried out by an unqualified individual, a fire, electric shocks, injury, water leakage, noise and/or vibration may result.
- If using separately sold products, make sure to use Toshiba specified products only. Using unspecified products may cause fire, electric shock, water leak or other failure.
- Do not use any refrigerant different from the one specified for complement or replacement. Otherwise, abnormally high pressure may be generated in the refrigeration cycle, which may result in a failure or explosion of the product or an injury to your body.
- Before opening the service panel of the outdoor unit, set the circuit breaker to the OFF position. Failure to set the circuit breaker to the OFF position may result in electric shocks through contact with the interior parts. Only a qualified installer (*1) or qualified service person (*1) is allowed to remove the service panel of the outdoor unit and do the work required.
- Before carrying out the installation, maintenance, repair or removal work, be sure to set the circuit breakers for both the indoor and outdoor units to the OFF position. Otherwise, electric shock may result.
- Place a "Work in progress" sign near the circuit breaker while the installation, maintenance, repair or removal work is being carried out. There is a danger of electric shocks if the circuit breaker is set to ON by mistake.
- Only a qualified installer (*1) or qualified service person (*1) is allowed to undertake work at heights using a stand of 50 cm or more or to remove the intake grille of the indoor unit to undertake work.
- Wear protective gloves and safety work clothing during installation, servicing and removal.
- Do not touch the aluminium fin of the outdoor unit. You may injure yourself if you do so. If the fin must be touched for some reason, first put on protective gloves and safety work clothing, and then proceed.
- Do not climb onto or place objects on top of the outdoor unit. You may fall or the objects may fall off of the outdoor unit and result in injury.
- When working at height, put a sign in place so that no-one will approach the work location before proceeding with the work. Parts or other objects may fall from above, possibly injuring a person below. Also, be sure that workers put on helmets.
- When cleaning the filter or other parts of the outdoor unit, set the circuit breaker to OFF without fail, and place a "Work in progress" sign near the circuit breaker before proceeding with the work.
- When working at heights, put a sign in place so that no-one will approach the work location, before proceeding with the work. Parts and other objects may fall from above, possibly injuring a person below.
- The refrigerant used by this air conditioner is the R410A.
- You shall ensure that the air conditioner is transported in stable condition. If you find any part of the product broken, contact your dealer.
- Do not disassemble, modify, repair or move the product yourself. Doing so may cause fire, electric shock, injury or water leaks. Ask a qualified installer or qualified service person to do any repairs or to move the product.
- Selection of installation location
- If you install the unit in a small room, take appropriate measures to prevent the refrigerant from exceeding the limit concentration even if it leaks. Consult the dealer from whom you purchased the air conditioner when you implement the measures. Accumulation of highly concentrated refrigerant may cause an oxygen deficiency accident.
- Do not install in a location where flammable gas may leak and accumulate around the unit, it may ignite and cause a fire.
- When transporting the air conditioner, wear shoes with protective toe caps, protective gloves and other protective clothing.
- When transporting the air conditioner, do not take hold of the bands around the packing carton. You may injure yourself if the bands should break.
- Install the indoor unit at least 2.5 m above the floor level since otherwise the users may injure themselves or receive electric shocks if they poke their fingers or other objects into the indoor unit while the air conditioner is running.
- Do not place any combustion appliance in a place where it is directly exposed to the wind of air conditioner, otherwise it may cause imperfect combustion.
- Places where the operation sound of the outdoor unit may cause a disturbance. (Especially at the boundary line with a neighbour, install the air conditioner while considering the noise.)
- Installation
- Follow the instructions in the Installation Manual to install the air conditioner. Failure to follow these instructions may cause the product to fall down or topple over or give rise to noise, vibration, water leakage or other failure.
- The designated bolts (M12) and nuts (M12) for securing the outdoor unit must be used when installing the unit.
- Install the outdoor unit properly in a location that is durable enough to support the weight of the outdoor unit. Insufficient durability may cause the outdoor unit to fall, which may result in injury.
- Install the unit in the prescribed manner for protection against strong wind and earthquake. Incorrect installation may result in the unit falling down, or other accidents.
- Be sure to fix the screws back which have been removed for installation or other purposes.

Refrigerant Piping

- Install the refrigerant pipe securely during the installation work before operating the air conditioner. If the compressor is operated with the valve open and without refrigerant pipe, the compressor sucks air and the refrigeration cycles is over pressurized, which may cause an injury.
- Tighten the flare nut with a torque wrench in the specified manner. Excessive tighten of the flare nut may cause a crack in the flare nut after a long period, which may result in refrigerant leakage.
- Ventilate the air if the refrigerant gas leaks during installation. If the leaked refrigerant gas comes into contact with fire, toxic gas may be produced.
- After the installation work, confirm that refrigerant gas does not leak. If refrigerant gas leaks into the room and flows near a fire source, such as a cooking range, noxious gas may be generated.
- When the air conditioner has been installed or relocated, follow the instructions in the Installation Manual and purge the air completely so that no gases other than the refrigerant will be mixed in the refrigerating cycle. Failure to purge the air completely may cause the air conditioner to malfunction.
- Nitrogen gas must be used for the airtight test.
- The charge hose must be connected in such a way that it is not slack.
- If refrigerant gas has leaked during the installation work, ventilate the room immediately. If the leaked refrigerant gas comes in contact with fire, noxious gas may be generated.

Electrical Wiring

- Only a qualified installer (*1) or qualified service person (*1) is allowed to carry out the electrical work of the air conditioner. Under no circumstances must this work be done by an unqualified individual since failure to carry out the work properly may result in electric shocks and/or electrical leaks.
- When connecting the electrical wires, repairing the electrical parts or undertaking other electrical jobs, wear gloves to provide protection for electricians and from heat, insulating shoes and clothing to provide protection from electric shocks. Failure to wear this protective gear may result in electric shocks.
- When executing address setting, test run, or troubleshooting through the checking window on the electrical control box, put on insulated heat-proof gloves, insulated shoes and other clothing to provide protection from electric shock. Otherwise you may receive an electric shock.
- Use wiring that meets the specifications in the Installation Manual and the stipulations in the local regulations and laws. Use of wiring which does not meet the specifications may give rise to electric shocks, electrical leakage, smoking and/or a fire.
- Check that the product is properly earthed. (grounding work) Incomplete earthing may cause electric shock.
- Do not connect the earth wire to a gas pipe, water pipe, lightning conductor, or a telephone earth wire.
- After completing the repair or relocation work, check that the ground wires are connected properly.
- Install a circuit breaker that meets the specifications in the installation manual and the stipulations in the local regulations and laws.
- Install the circuit breaker where it can be easily accessed by the agent.
- When installing the circuit breaker outdoors, install one which is designed to be used outdoors.
- Under no circumstances must the power cable be extended. Connection trouble in the places where the cable is extended may give rise to smoking and/or a fire.
- Electrical wiring work shall be conducted according to law and regulation in the community and installation manual. Failure to do so may result in electrocution or short circuit.
- Do not supply power from the power terminal block equipped on the outdoor unit to another outdoor unit. Capacity overflow may occur on the terminal block and may result in fire.
- When carrying out electric connection, use the wire specified in the Installation Manual and connect and fix the wires securely to prevent them applying external force to the terminals. Improper connection or fixing may result in fire.

Test Run

- Before operating the air conditioner after having completed the work, check that the electrical control box cover of the indoor unit and service panel of the outdoor unit are closed, and set the circuit breaker to the ON position. You may receive an electric shock if the power is turned on without first conducting these checks.
- When you have noticed that some kind of trouble (such as when an error display has appeared, there is a smell of burning, abnormal sounds are heard, the air conditioner fails to cool or heat or water is leaking) has occurred in the air conditioner, do not touch the air conditioner yourself but set the circuit breaker to the OFF position, and contact a qualified service person. Take steps to ensure that the power will not be turned on (by marking "out of service" near the circuit breaker, for instance) until qualified service person arrives. Continuing to use the air conditioner in the trouble status may cause mechanical problems to escalate or result in electric shocks or other failure.
- After the work has finished, be sure to use an insulation tester set (500 V Megger) to check the resistance is 2 MΩ or more between the charge section and the non-charge metal section (Earth section). If the resistance value is low, a disaster such as a leak or electric shock is caused at user's side.
- Upon completion of the installation work, check for refrigerant leaks and check the insulation resistance and water drainage. Then conduct a test run to check that the air conditioner is operating properly.

Explanations Given To User

- Upon completion of the installation work, tell the user where the circuit breaker is located. If the user does not know where the circuit breaker is, he or she will not be able to turn it off in the event that trouble has occurred in the air conditioner.
- If you have discovered that the fan grille is damaged, do not approach the outdoor unit but set the circuit breaker to the OFF position, and contact a qualified service person(*1) to have the repairs done. Do not set the circuit breaker to the ON position until the repairs are completed.
- After the installation work, follow the Owner's Manual to explain to the customer how to use and maintain the unit.

Relocation

- Only a qualified installer (*1) or qualified service person (*1) is allowed to relocate the air conditioner. It is dangerous for the air conditioner to be relocated by an unqualified individual since a fire, electric shocks, injury, water leakage, noise and/or vibration may result.
- When carrying out the pump-down work shut down the compressor before disconnecting the refrigerant pipe. Disconnecting the refrigerant pipe with the service valve left open and the compressor still operating will cause air or other gas to be sucked in, raising the pressure inside the refrigeration cycle to an abnormally high level, and possibly resulting in rupture, injury or other trouble.
- Never recover the refrigerant into the outdoor unit. Be sure to use a refrigerant recovery machine to recover the refrigerant when moving or repairing. It is impossible to recover the refrigerant into the outdoor unit. Refrigerant recovery into the outdoor unit may result in serious accidents such as explosion of the unit, injury or other accidents.

(*1) Refer to the "Definition of Qualified Installer or Qualified Service Person."



CAUTION

New refrigerant air conditioner installation

- **This air conditioner adopts the new HFC refrigerant (R410A) which does not destroy ozone layer.**
- The characteristics of R410A refrigerant are; easy to absorb water, oxidizing membrane or oil, and its pressure is approx. 1.6 times higher than that of refrigerant R22. Accompanied with the new refrigerant, refrigerating oil has also been changed. Therefore, during installation work, be sure that water, dust, former refrigerant, or refrigerating oil does not enter the refrigerating cycle.
- To prevent charging an incorrect refrigerant and refrigerating oil, the sizes of connecting sections of charging port of the main unit and installation tools are changed from those for the conventional refrigerant.
- Accordingly the exclusive tools are required for the new refrigerant (R410A).
- For connecting pipes, use new and clean piping designed for R410A, and please care so that water or dust does not enter.

Disconnection of the appliance from mains power supply.

- This appliance must be connected to the main power supply by means of a switch with a contact separation of at least 3 mm.

The installation fuse (all type can be used) must be used for the power supply line of this conditioner.

2 Installation of New Refrigerant Air Conditioner

This air conditioner adopts the new HFC refrigerant (R410A) which does not deplete the ozone layer.

- R410A refrigerant is vulnerable to impurities such as water, oxidizing membranes, or oils because the pressure of R410A refrigerant is higher than that of the former refrigerant by approximately 1.6 times.
- As well as the adoption of the new refrigerant, the refrigerating oil has been also changed. Therefore, pay attention so that water, dust, former refrigerant, or refrigerating oil does not enter the refrigerating cycle of the new refrigerant air conditioner during installation.
- To prevent mixing of refrigerant or refrigerating oil, the size of the charge port of the main unit or connecting section of the installation tool differs to that of an air conditioner for the former refrigerant. Accordingly, exclusive tools are required for the new refrigerant (R410A) as shown below.
- For connecting pipes, use new and clean piping materials so that water or dust does not enter.

■ Required Tools and Cautions on Handling

It is necessary to prepare the tools and parts for installation as described below. The tools and parts which will be newly prepared in the following items should be restricted to exclusive use.

Explanation of symbols

- △ : Newly prepared (It is necessary to use it exclusively with R410A, separately from those for R22 or R407C.)
 ○ : Former tool is available.

Used Tools	Usage	Proper Use of Tools / Parts
Gauge manifold	Vacuuming, charging refrigerant and operation check	△ Exclusive to R410A
Charging hose		△ Exclusive to R410A
Charging cylinder	Charging refrigerant	Unusable (Use the Refrigerant charging balance.)
Gas leak detector	Checking gas leak	△ Exclusive to R410A
Vacuum pump	Vacuum drying	Usable if a counter-flow preventive adapter is attached
Vacuum pump with counter flow	Vacuum drying	○ R22 (Existing article)
Flare tool	Flare processing of pipes	○ Usable by adjusting size
Bender	Bending processing of pipes	○ R22 (Existing article)
Refrigerant recovery device	Recovering refrigerant	△ Exclusive to R410A
Torque wrench	Tightening flare nut	△ Exclusive to Ø12.7mm and Ø15.9mm
Pipe cutter	Cutting pipes	○ R22 (Existing article)
Refrigerant canister	Charging refrigerant	△ Exclusive to R410A Enter the refrigerate name for identification
Welding machine / Nitrogen gas cylinder	Welding of pipes	○ R22 (Existing article)
Refrigerant charging balance	Charging refrigerant	○ R22 (Existing article)

3 Selection of Installation Place

Upon customer's approval, install the air conditioning apparatus in a place which satisfies the following conditions:

- Place where it can be installed horizontally.
- Place which can reserve a sufficient service space for safe maintenance or checks.
- Place where there is no problem even if the drained water overflows.

Avoid the following places:

- Salty places (seaside area) or places with much gas sulphide (hot spring area) (If selecting such a place, special maintenance is required.)
- Places where oil (including machine oil), steam, oil smoke or corrosive gas is generated.
- Places where iron or other metal dust is present. If iron or other metal dust adheres to or collects on the interior of the air conditioner, it may spontaneously combust and start a fire.
- Places where an organic solvent is used.
- Chemical plants with a cooling system using liquid carbon dioxide.
- Places where a device generating high frequency (inverter, non-utility generator, medical apparatus, or communication equipment) is set. (Malfunction or abnormal control of the air conditioner, or interference to devices listed above may occur.)
- Places unable to bear the weight of the apparatus.
- Places with poor ventilation.
- Places where ambient temperature falls below -15°C for more than 72 hours running.

4 Refrigerant Piping

■ GAS Label

The air conditioning product contains fluorinated greenhouse gases covered by the Kyoto Protocol

Chemical Name of Gas R410A

Global Warming Potential (GWP) of Gas 1975



1. Stick the enclosed refrigerant label adjacent to the charging and/or recovering location.
2. Clearly write the charged refrigerant quantity on the refrigerant label using indelible ink. Then, place the included transparent protective sheet over the label to prevent the writing from rubbing off.
3. Prevent emission of the contained fluorinated greenhouse gas. Ensure that the fluorinated greenhouse gas is never vented to the atmosphere during installation, service or disposal. When any leakage of the contained fluorinated greenhouse gas is detected, the leak shall be stopped and repaired as soon as possible.
4. Only qualified service personnel are allowed to access and service this product.
5. Any handling of the fluorinated greenhouse gas in this product, such as when moving the product or recharging the gas, shall comply under (EC) Regulation No. 842/2006 on certain fluorinated greenhouse gases and any relevant local legislation.
6. Periodical inspections for refrigerant leaks may be required depending on European or local legislation.
7. Contact dealers, installers, etc., for any questions.

! WARNING

- If the refrigerant gas leaks during installation, ventilate the room. If the leaked refrigerant gas comes into contact with fire, noxious gas may be generated.
- After installation, check that the refrigerant gas does not leak.
- If the refrigerant gas leaks into the room and comes into contact with fire such as a fan heater, stove, or kitchen range, noxious gas may be generated.

REQUIREMENT

- For a brazing work of the refrigerant pipes, be sure to use nitrogen gas in order to prevent oxidation of the inside of the pipes; otherwise clogging of the refrigerating cycle due to oxidized scale may occur.
- Use clean and new pipes for the refrigerant pipes and perform piping work so that water or dust does not contaminate the refrigerant.
- *Remove all flux after brazing.
- Be sure to use a double spanner to loosen or tighten the flare nut. If a single spanner is used, the required level of tightening cannot be obtained. Tighten the flare nut with the specified torque. (If it is hard to loosen or tighten the flare nut of the balance pipe or packed valve of the liquid side with a double spanner, loosen or tighten the flare nut while holding the valve mounting plate with a spanner.)

Extruding margin of copper pipe with flare tools: A (Unit: mm)

Copper pipe outer dia.	+0 A -0.4
9.5	13.2
12.7	16.6
15.9	19.7
19.1	24.0

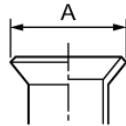

Connected section	
External size	Internal size

Extruding margin of copper pipe with flare machining: B (Unit: mm)

Copper pipe outer dia.	When using R410A tool	When using conventional tool
9.5 12.7 15.9 19.1	0 to 0.5	1.0 to 1.5

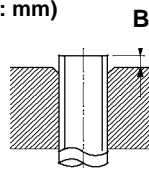

- When using the conventional flare tool, to connect R410A pipes with flaring, make a margin approx. 0.5 mm longer than that of an R22 pipe so that the flare size matches the one specified. It is convenient to use a copper pipe gauge for size adjustment of the extruding margin. Half hard or hard materials may be cracked and may cause leakage of refrigerant when it is flared.
- After flaring the connection, be sure the flared part is not damaged, deformed, uneven, or flattened, and that there are no cutting chips on it. Coupling size of brazed pipe

Standard outer dia. of connected copper pipe	Connected section				Min. depth of insertion	Oval value	Min. thickness of coupling
	External size	Internal size					
	Standard outer dia. (Allowable difference)		K	G			
	C	F					
6.35	6.35 (±0.03)	6.45 (+0.04/-0.02)	7	6	0.06 or less	0.50	
9.52	9.52 (±0.03)	9.62 (+0.04/-0.02)	8	7	0.08 or less	0.60	
12.70	12.70 (±0.03)	12.81 (+0.04/-0.02)	9	8	0.10 or less	0.70	
15.88	15.88 (±0.03)	16.00 (+0.04/-0.02)	9	8	0.13 or less	0.80	
19.05	19.05 (±0.03)	19.19 (+0.03/-0.03)	11	10	0.15 or less	0.80	
22.22	22.22 (±0.03)	22.36 (+0.03/-0.03)	11	10	0.16 or less	0.82	
28.58	28.58 (±0.04)	28.75 (+0.06/-0.02)	13	12	0.20 or less	1.00	
34.92	34.90 (±0.04)	35.11 (+0.04/-0.04)	14	13	0.25 or less	1.20	
38.10	38.10 (±0.05)	38.31 (+0.08/-0.02)	15	14	0.27 or less	1.26	
41.28	41.28 (±0.05)	41.50 (+0.08/-0.02)	15	14	0.28 or less	1.35	

■ Warnings on Refrigerant Leakage

Check of Concentration Limit

The room in which the air conditioner is to be installed requires a design that in the event of refrigerant gas leaking out, its concentration will not exceed a set limit.

The refrigerant R410A which is used in the air conditioner is safe, without the toxicity or combustibility of ammonia, and is not restricted by laws to be imposed which protect the ozone layer. However, since it contains more than air, it poses the risk of suffocation if its concentration should rise excessively. Suffocation from leakage of R410A is almost non-existent. With the recent increase in the number of high concentration buildings, however, the installation of multi air conditioner systems is on the increase because of the need for effective use of floor space, individual control, energy conservation by curtailing heat and carrying power etc.

Most importantly, the multi air conditioner system is able to replenish a large amount of refrigerant compared with conventional individual air conditioners. If a single unit of the multi conditioner system is to be installed in a small room, select a suitable model and installation procedure so that if the refrigerant accidentally leaks out, its concentration does not reach the limit (and in the event of an emergency, measures can be made before injury can occur).

1. In a room where the concentration may exceed the limit, create an opening with adjacent rooms, or install mechanical ventilation combined with a gas leak detection device. The concentration is calculated as detailed below.

$$\frac{\text{Total amount of refrigerant (kg)}}{\text{Min. volume of the indoor unit installed room (m}^3\text{)}} \leq \text{Concentration limit (kg/m}^3\text{)}$$

The concentration limit of R410A which is used in multi air conditioners is 0.3 kg/m³.

▼ NOTE 1

If there are 2 or more refrigerating systems in a single refrigerating device, the amounts of refrigerant should be as charged in each independent device.

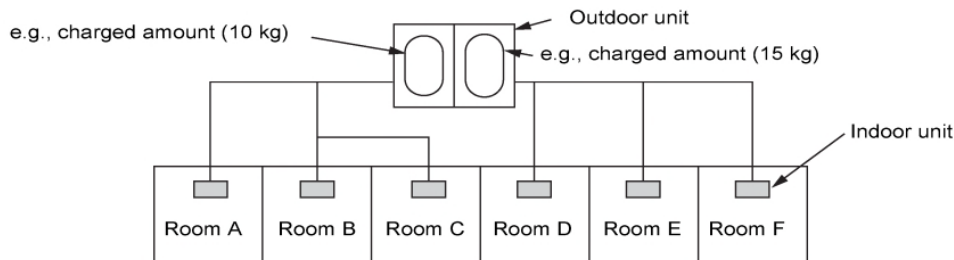

For the amount of charge in this example:

The possible amount of leaked refrigerant gas in rooms A, B and C is 10 kg. The possible amount of leaked refrigerant gas in rooms D, E and F is 15 kg.

▼ NOTE 2

The standards for minimum room volume are as follows. 1) No partition (shaded portion)

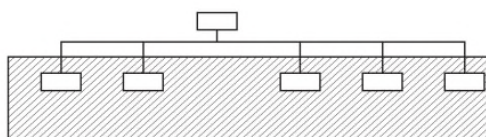

IMPORTANT

- When there is an effective opening with the adjacent room for ventilation of leaking refrigerant gas (opening without a door, or an opening 0.15 % or larger than the respective floor spaces at the top or bottom of the door).

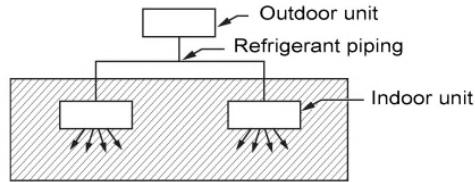

- If an indoor unit is installed in each partitioned room and the refrigerant piping is interconnected, the smallest room of course becomes the object. But when a mechanical ventilation is installed interlocked with a gas leakage detector in the smallest room where the density limit is exceeded, the volume of the next smallest room becomes the object.

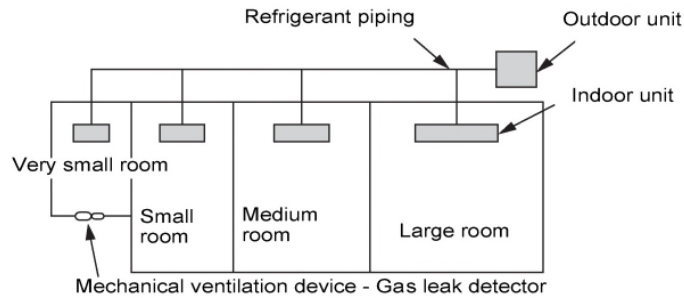

▼ NOTE 3

The minimum indoor floor area compared with the amount of refrigerant is roughly as follows: (When the ceiling is 2.7 m high)

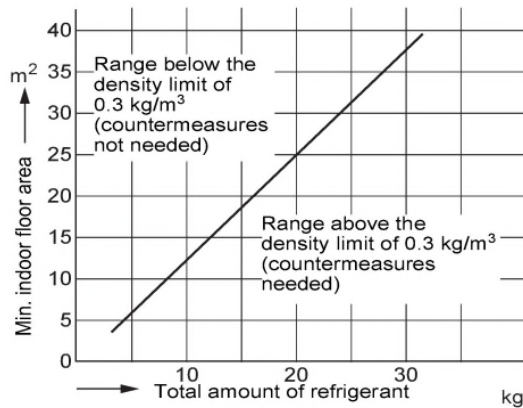

5 Electric wiring

WARNING

The appliance shall be installed in accordance with national wiring regulations.
Capacity shortages of the power circuit or an incomplete installation may cause an electric shock or fire.

CAUTION

- Perform wiring of power supply complying with the rules and regulations of the local electric company.
- Refer to H07RN-F or 60245 IEC 66 regarding specifications of the power supply wire.
- Do not connect 380 V - 415 V power to the terminal blocks for control cables (U1, U2, U3, U4, U5, U6); otherwise, the unit may break down.
- Be sure that electric wiring does not come into contact with high-temperature parts of piping; otherwise, the coating of cables may melt and cause an accident.
- After connecting wires to the terminal block, take off the traps and fix the wires with cord clamps.
- Follow the same structure for both the control wiring and refrigerate piping.
- Do not conduct power to indoor units until vacuuming of the refrigerant pipes has finished.
- Refer to the installation manuals of indoor unit and flow selector unit for power wiring and communication wiring of indoor unit and flow selector unit.
- Communication wiring and central control wiring use 2-core non-polarity wires. Use 2-core shield wires to prevent noise trouble.
- Connecting the closed end terminal of shield wire. (Connected to all connecting sections in each unit)
- Use 2-core non-polarity wire for remote controller. (A, B terminals) Use 2-core non-polarity wire for wiring of group control. (A, B terminals)

Table-1 Communication wiring between indoor and outdoor units (L1, L2, L3), Central control wiring (L4)

Wiring	2-core, non-polarity
Type	Shield wire
Size / Length	1.50mm ² (min. 1.25 mm ²): Up to 1000m 2.50mm ² (min. 2.00 mm ²): Up to 2000m (*1)

(*1): Total length of Communication wiring length for all refrigerant circuits (L1 + L2 + L3 + L4)

Table-2 Communication wiring between outdoor units (L5)

Wiring	2-core, non-polarity
Type	Shield wire
Size / Length	1.50mm ² (min. 1.25 mm ² to 2.0 mm ²) up to 100m (L5)

Table-3 Remote controller wiring (L6, L7)

Wire	2-core, non-polarity
Size	1.50mm ² (min. 0.5 mm ² to 2.0 mm ²)
Length	Up to 500m (L6 + L7) Up to 400m in case of wireless remote controller in group control. Up to 200m total length of communication wiring between indoor units L6

6 REASSEMBLY INSTRUCTIONS FOR VRF OUTDOOR UNIT

The outdoor unit requires careful reassembly. It has been deconstructed from its factory built state, to facilitate installation in a location that has limited or no access by means of craneage or by mechanical lifting equipment.

Prior to deconstruction the equipment has been FULLY run and tested.

During the deconstruction process of the respective refrigerant components OXYGEN FREE NITROGEN (OFN), has been used at ALL TIMES.

ALL refrigeration components have been shipped with a standing charge of OFN, with "Schrader type valves fitted, to prevent and eliminate any possible moisture contamination.

Shipment has been separated into three separate pallets per unit, each pallet contains components required to reassemble the outdoor unit.

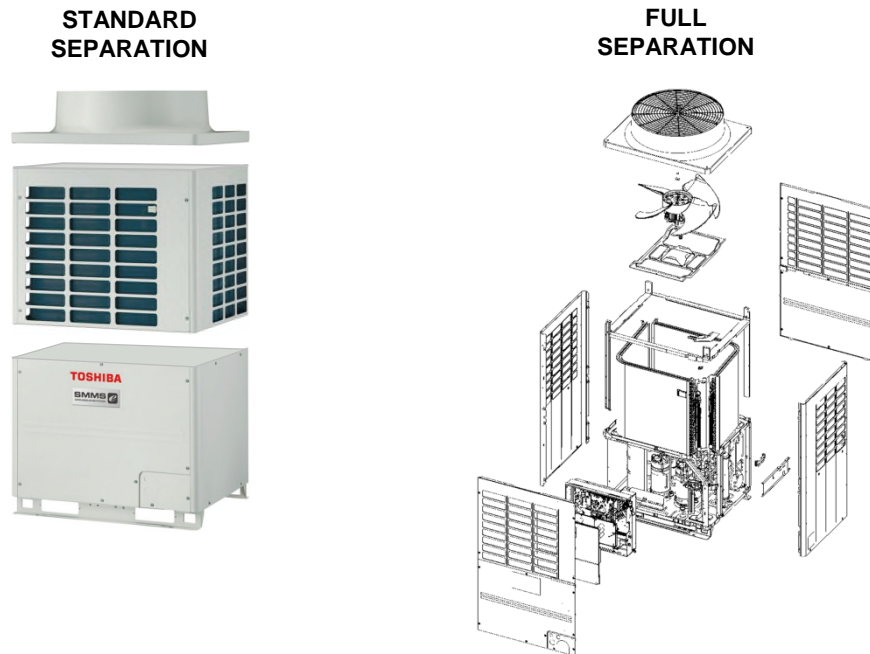

■ OUTDOOR UNIT REASSEMBLY REQUIREMENTS

1. F-Gas qualified person and assistant.
2. Level safe working area clear of debris and suitable for brazing works.
3. Suitably sized Oxy-Acetylene brazing equipment, brazing rods and flux. All pipe joints will be copper to copper.
4. Sufficient quantity of Oxygen Free Nitrogen, (OFN) and associated gauges and lines.
5. Vacuum pump, approximate size 4 CFM or better.
6. HVAC Vacuum (Torr) gauge.
7. New virgin R410A refrigerant gas, each unit will requires an outdoor unit base charge plus additional installed liquid line length charge for the installed system.
8. Refrigeration designated weighing scales.
9. General HVAC tools and R410A manifold gauge with lines.
10. R410A refrigerant leak tester.
11. Electrical testing equipment.

We recommend that reassembly of the unit and components should take place under dry conditions.

■ PROCEDURE FOR REASSEMBLY

IMPORTANT

IT IS IMPERATIVE that during the reassembly process, OFN is “Purged” through the system to eliminate and prevent any build-up of “OXIDATION (Carbon Deposits)” and reduce the risk of contamination to the refrigeration system.



In addition to the main pipe connections, the injection pipes must also be connected.

Refit the heat exchanger drainage channel

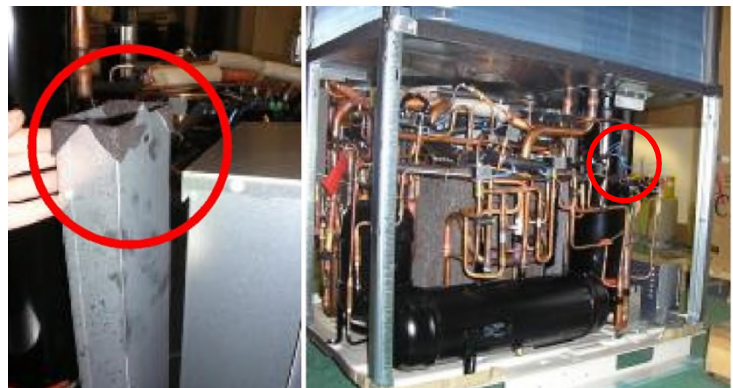

Re-connect the “Hot Gas Injection Circuit”



Re-connect the “base” refrigeration pipes. The pipes are routed through the drain pan assembly Please note all connections are colour coded for easier assembly.

The “Heat Exchanger” now requires mounting on the base drain pan assembly all refrigeration lines are colour coded for easier assembly.

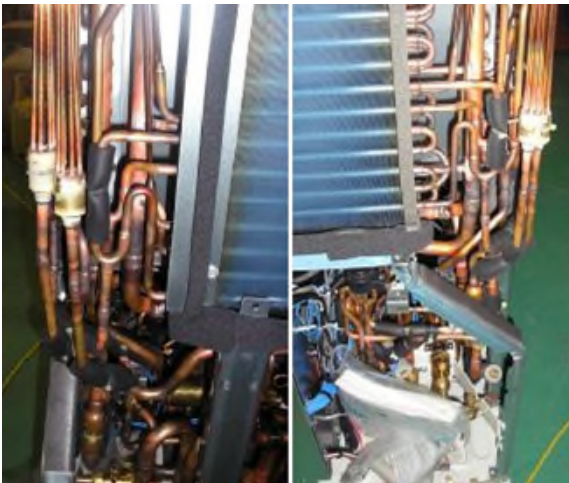

Pipe work after reconnection.

After assembly of all refrigerant lines the electrical cables must be routed via the front right hand side panel and reconnected.



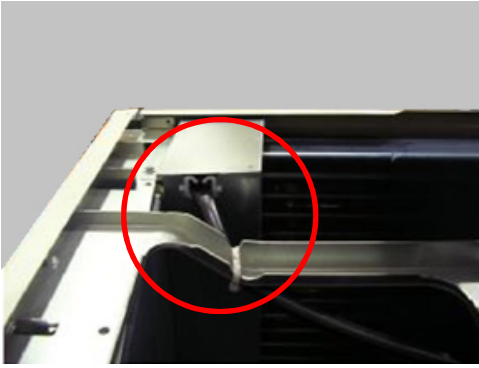

The discharge fan assembly cables must be routed through from the front right hand side panel and reconnected.

The ambient temperature sensor must be mounted and fixed in front of the heat exchanger

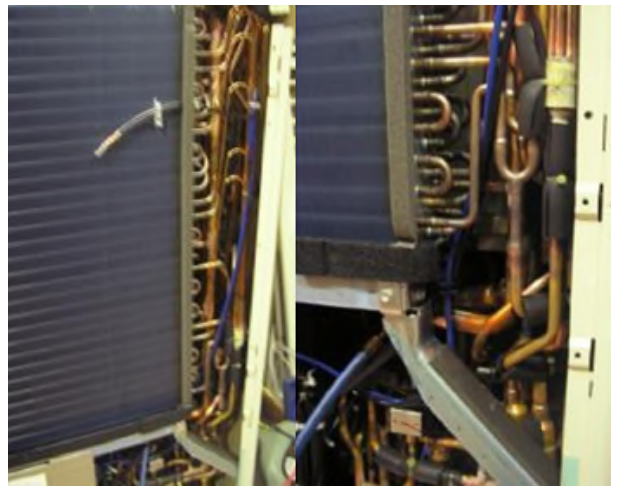

■ COMPLETION & TESTING

⚠ IMPORTANT



After reassembly of the internal components the outer casing must be secured with the supplied screws.

On completion of reassembly of the outdoor unit the refrigerant circuit must be "leak and strength" tested in accordance with F-Gas regulations.

On satisfactory completion of pressure testing the outdoor unit must be "triple evacuated".

A "triple evacuation" comprises of the following 6 stages: -

1. Evacuate the system to 1000 microns, via all service valves.
2. Break the vacuum with OFN to 15 psig
3. Evacuate the system to 500 microns.
4. Break the vacuum with OFN to 15 psig
5. Evacuate the system to the lowest pressure the vacuum pump can achieve, hold this vacuum for a minimum of 1 hour.
6. Allow the system to stand with a vacuum (Torr) gauge connected but with the vacuum pump DISCONNECTED, for a period of 30 minutes.

7 EXPLODED DIAGRAM/PARTS LIST

SMMS-e OUTDOOR UNIT

MMY-MAP0806HT8P-E, MAP1006HT8P-E, MAP1206HT8P-E

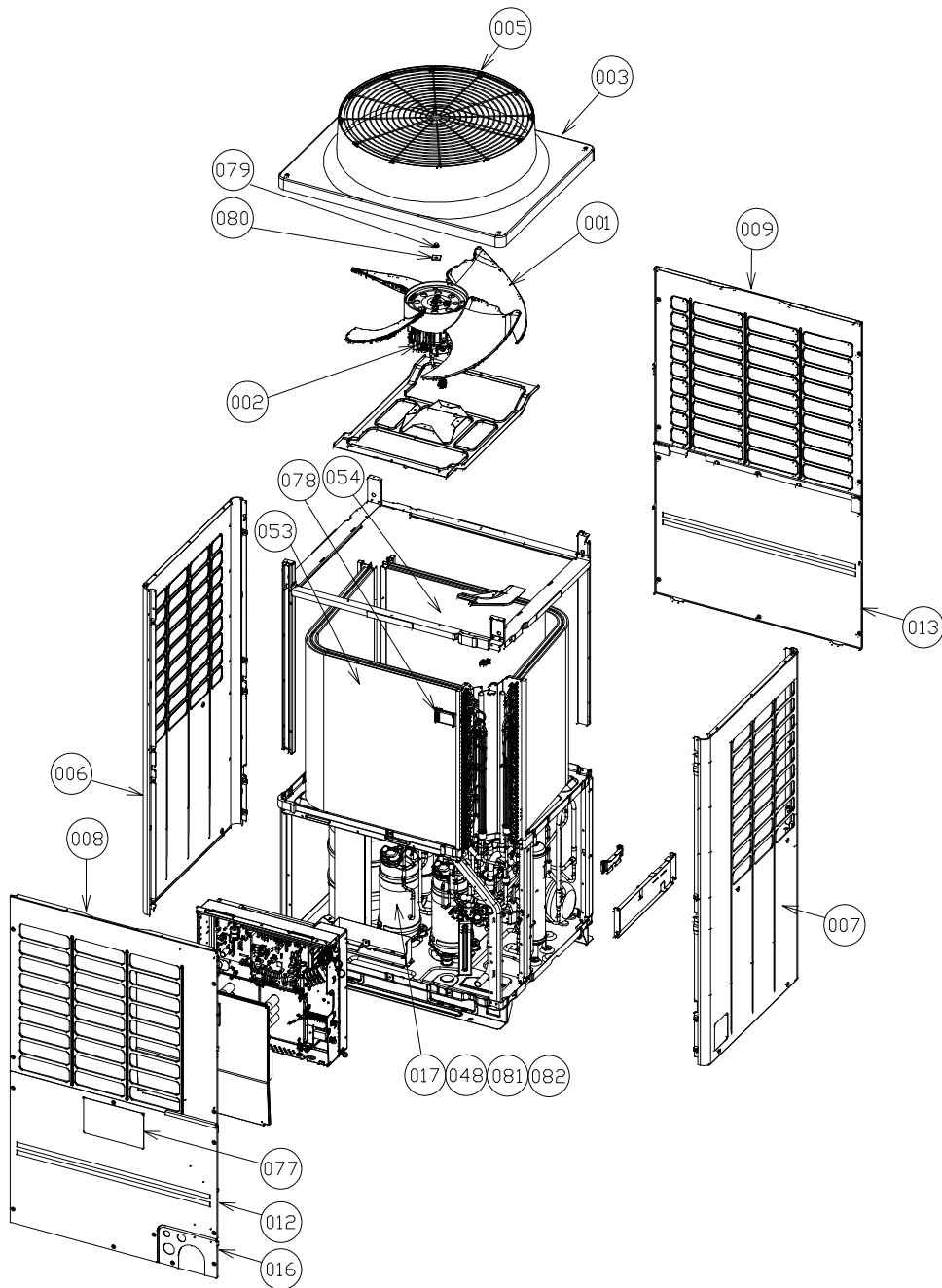

For 6HT8P-E model

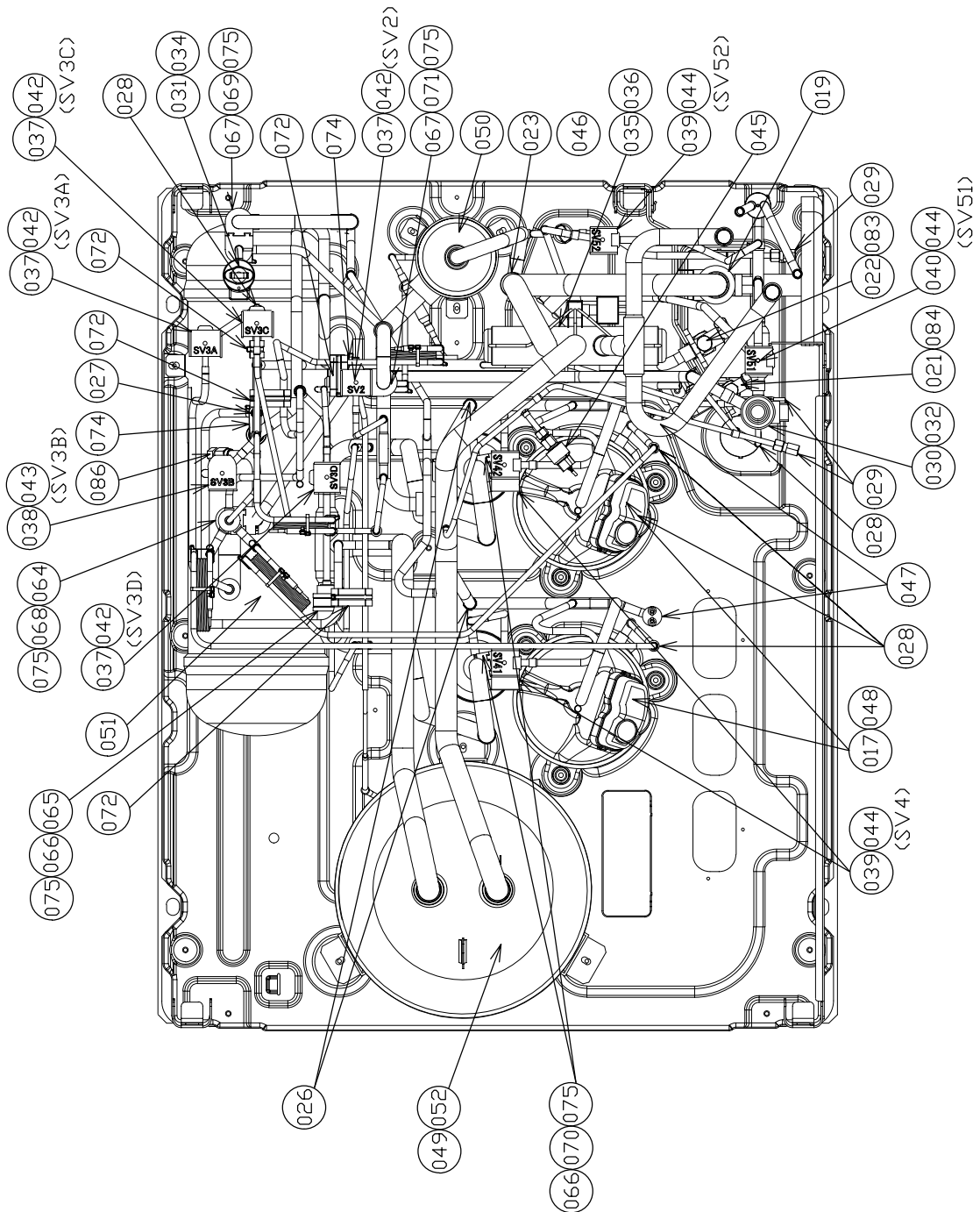

Outdoor Unit (8, 10, 12HP)
Model: MMY-MAP0806*, MMY-MAP1006*, MMY-MAP1206*
REFRIGERATION CIRCUIT DIAGRAM

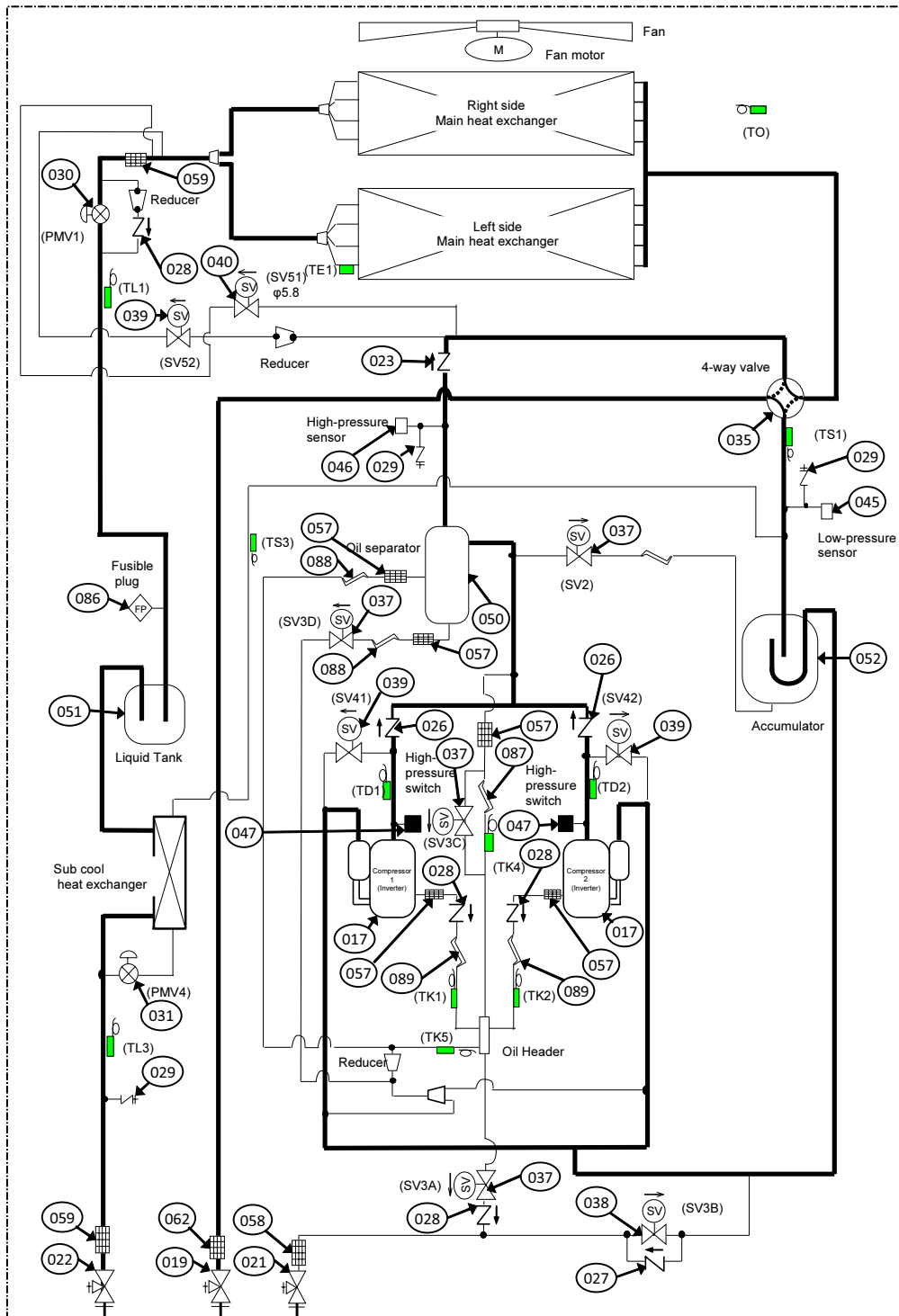

Liquid side Service valve Gas side Service valve Balance pipe Service valve

Symbol						
Solenoid valve	Capillary tube	Check valve	Check joint	Strainer	Temperature sensor	Distributor

SMMS-e OUTDOOR UNIT
MMY-MAP1406HT8P-E, MAP1606HT8P-E

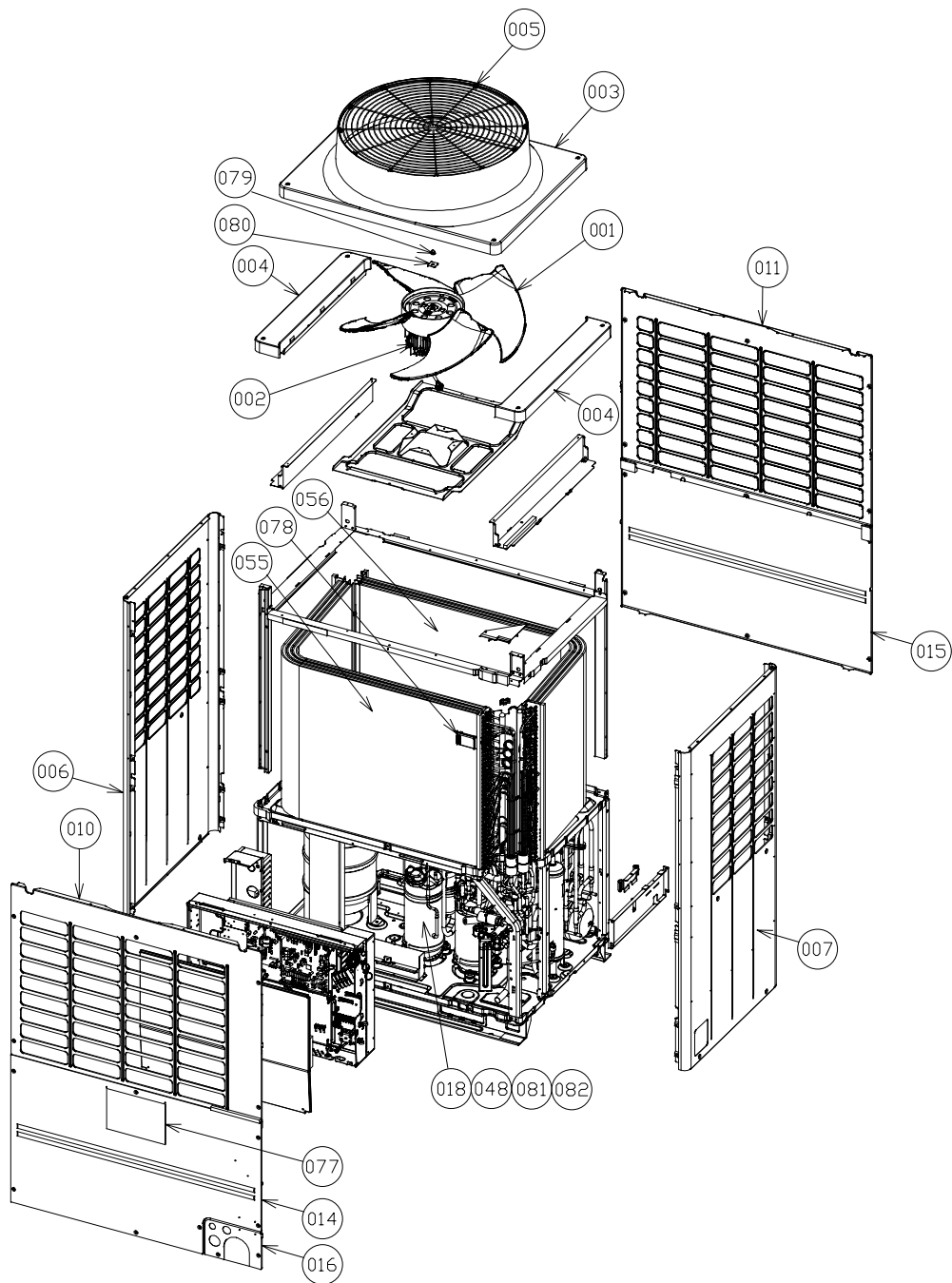

Outdoor Unit (14, 16HP)
Model: MMY-MAP1406*, MMY-MAP1606*
REFRIGERATION CIRCUIT DIAGRAM

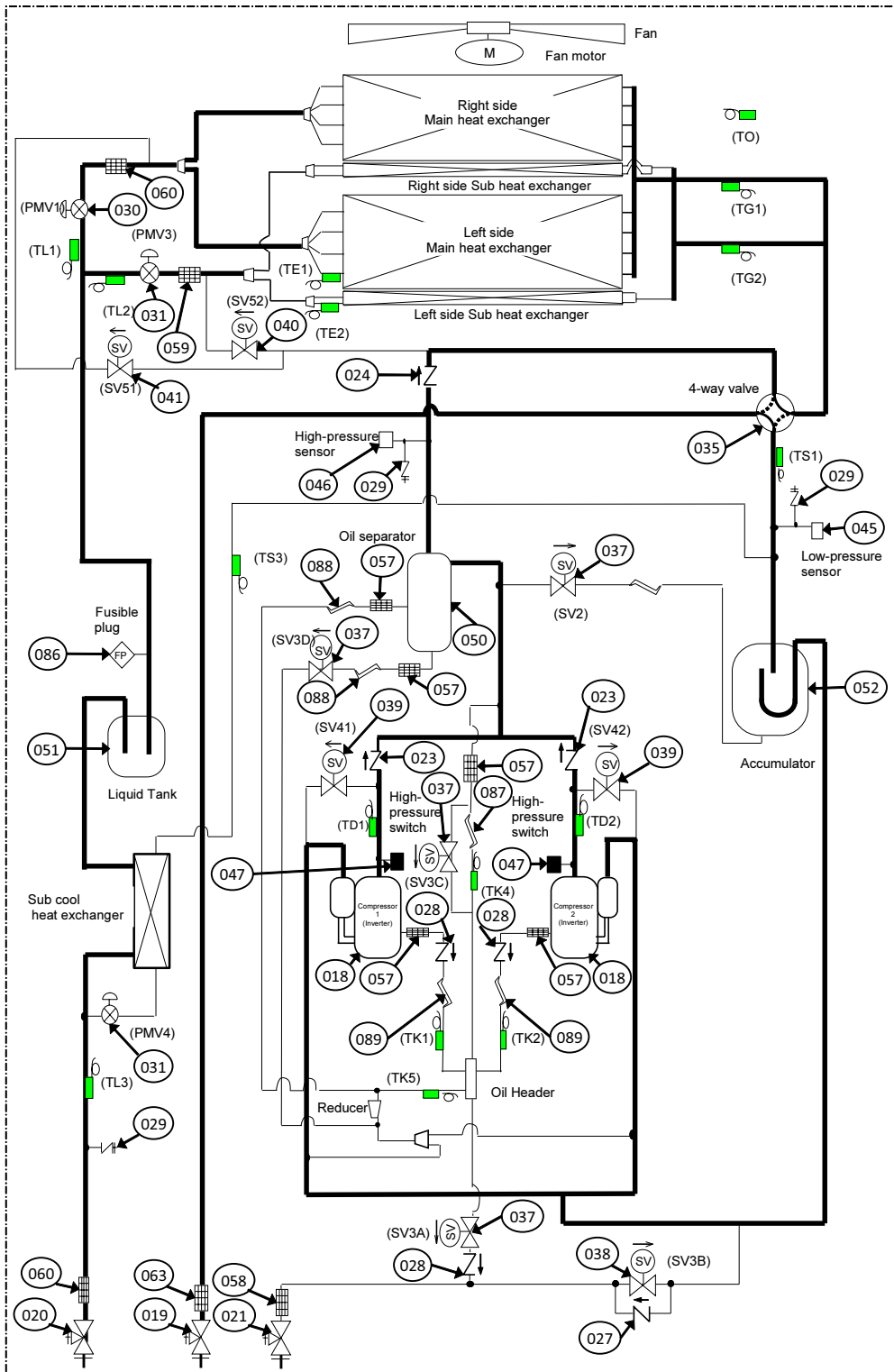

Liquid side Service valve Gas side Service valve Balance pipe Service valve

Symbol						
Solenoid valve	Capillary tube	Check valve	Check joint	Strainer	Temperature sensor	Distributor

SMMS-e OUTDOOR UNIT
MMY-MAP1806HT8P-E, MAP2006HT8P-E, MAP2206HT8P-E

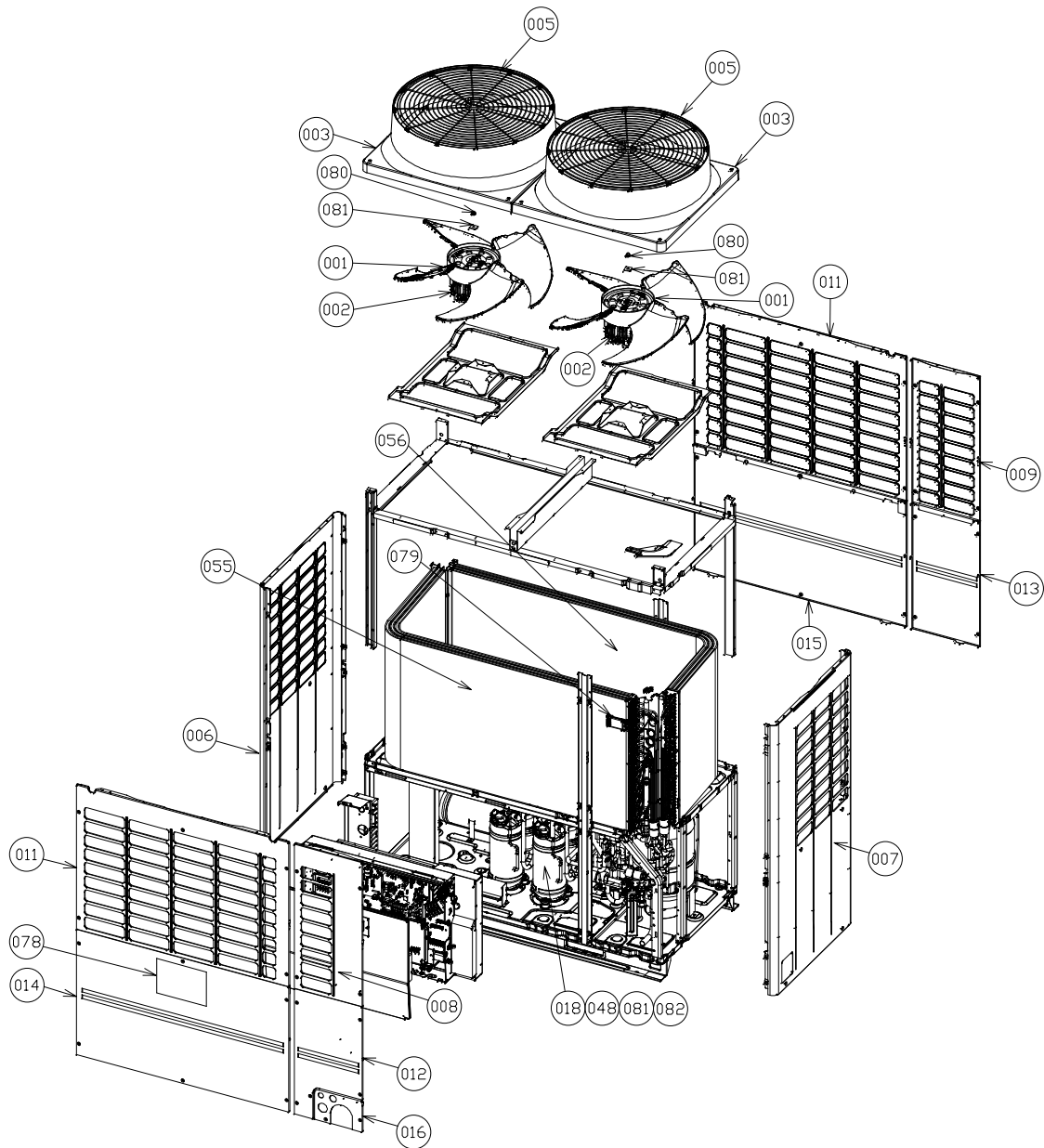

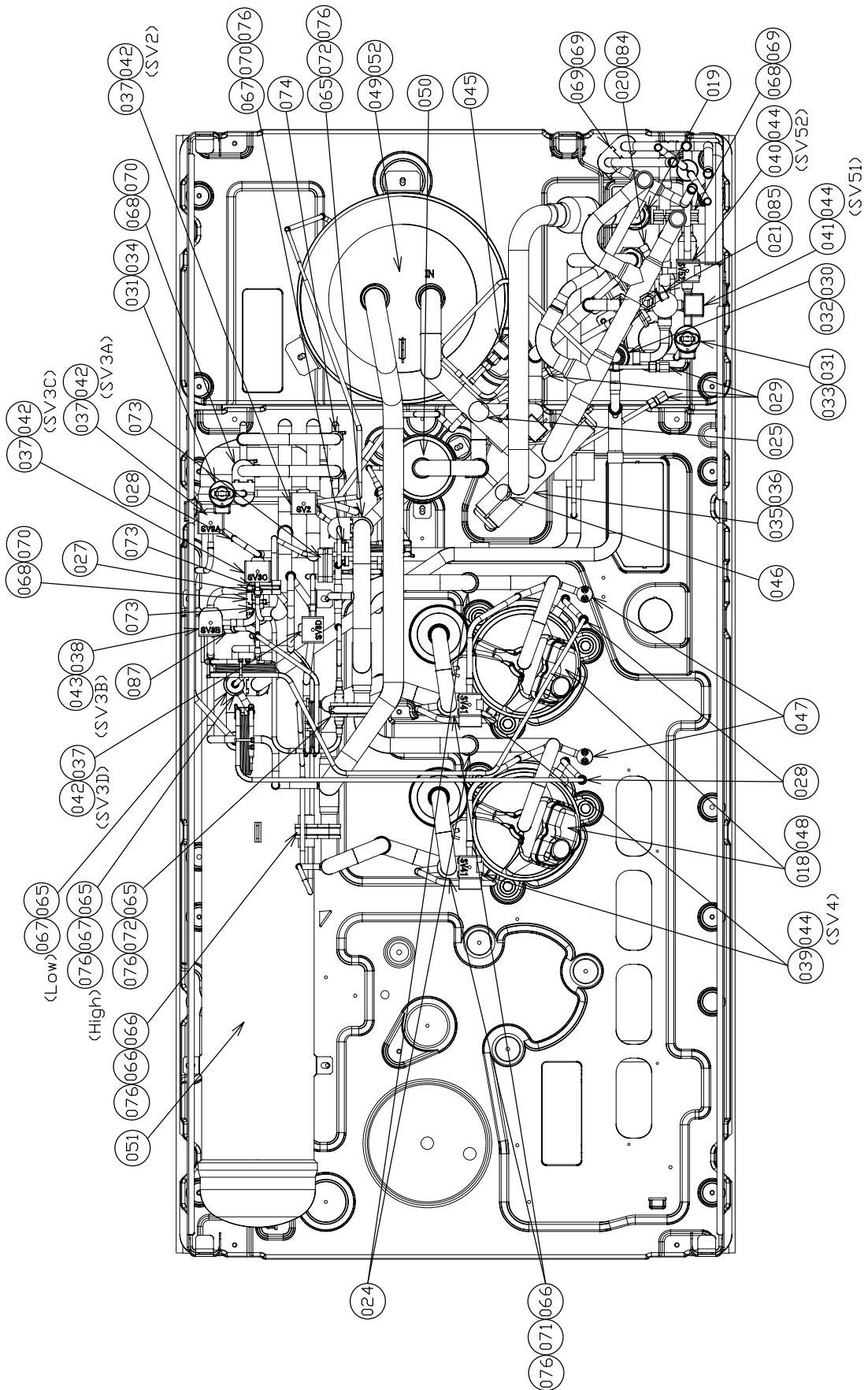

Outdoor Unit (18, 20, 22HP)
Model: MMY-MAP1806*, MMY-MAP2006*, MMY-MAP2206*
REFRIGERATION CIRCUIT DIAGRAM

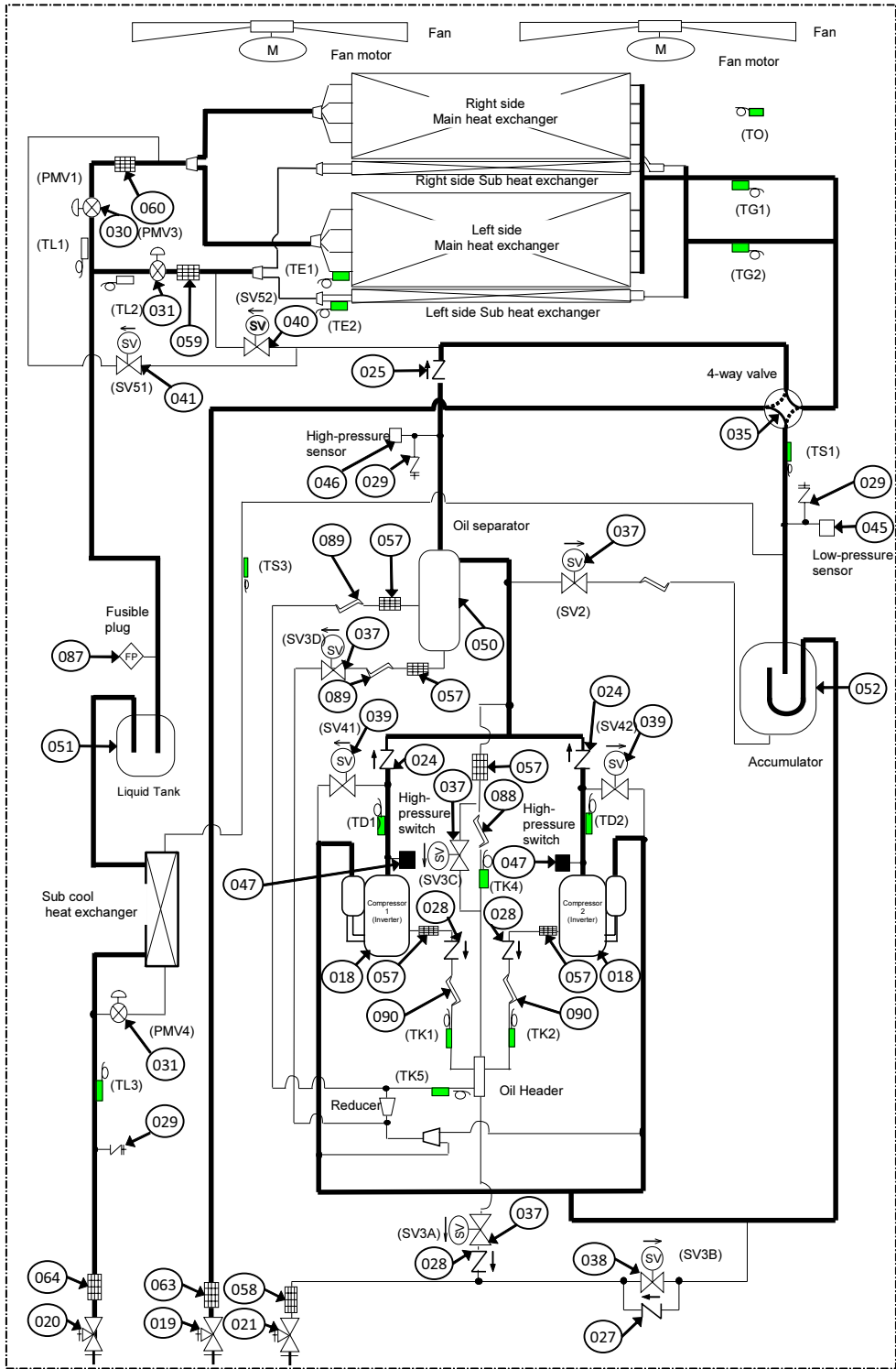

Liquid side Service valve Gas side Service valve Balance pipe Service valve

Symbol						
Solenoid valve	Capillary tube	Check valve	Check joint	Strainer	Temperature sensor	Distributor

For 6HT8P-E model

Ref. No.	Part No.	Description	Q'ty/Set MMY-				
			MAP0806 HT8(J)P	MAP1006 HT8(J)P	MAP1206 HT8(J)P	MAP1406 HT8(J)P	MAP1606 HT8(J)P
001	43T20341	FAN, PROPELLER	1	1	1	1	1
002	43T20342	MOTOR, FAN, DC530-620V, 2300L	1	1	1	1	1
003	43T19354	CABINET, AIR OUTLET	1	1	1	1	1
004	43T19355	CABINET, SIDE, UP				2	2
005	43T19359	GUARD, FAN	1	1	1	1	1
006	43T00613	CABINET ASSY, SIDE, LEFT	1	1	1	1	1
007	43T00614	CABINET ASSY, SIDE, RIGHT	1	1	1	1	1
008	43T00624	CABINET, AIR INLET, FRONT	1	1	1		
009	43T00620	CABINET, AIR INLET, BACK	1	1	1		
010	43T00625	CABINET, AIR INLET, FRONT				1	1
011	43T00622	CABINET, AIR INLET, BACK				1	1
012	43T00615	CABINET ASSY, FRONT, DOWN	1	1	1		
013	43T00616	CABINET ASSY, BACK, DOWN	1	1	1		
014	43T00617	CABINET ASSY, FRONT, DOWN				1	1
015	43T00618	CABINET ASSY, BACK, DOWN				1	1
016	43T00623	PANEL	1	1	1	1	1
017	43T41458	COMPRESSOR, RA421A3TB-20MD	2	2	2		
018	43T41485	COMPRESSOR, RA641A3TB-20M				2	2
019	43T46393	VALVE, BALL, 25.4	1	1	1	1	1
020	43T46381	VALVE, BALL, SBV-JA5GTC-1				1	1
021	43T46366	VALVE, PACKED, 9.52	1	1	1	1	1
022	43T46374	VALVE, PACKED, 12.7	1	1	1		
023	43T46444	VALVE, CHECK, UCV-A1505DRQ5	1	1	1	2	2
024	43T46445	VALVE, CHECK, UCV-A1506DRQ5				1	1
025	43T46446	VALVE, CHECK, UCV-A1507DR					
026	43T46398	VALVE, CHECKED, BCV-804DY	2	2	2		
027	43T46399	VALVE, CHECK, BCV-603DY	1	1	1	1	1
028	43T46400	VALVE, CHECKED, BCV-302DY	4	4	4	3	3
029	43T46409	JOINT,CHECK	3	3	3	3	3
030	43T46447	VALVE, PMV, PAM-BA2YGTF-1 (φ4.8)	1	1	1	1	1
031	43T46448	VALVE, PMV, UKV-25D100 (φ2.5)	1	1	1	2	2
032	43T46449	COIL, PMV	1	1	1	1	1
033	43T46450	COIL, PMV				1	1
034	43T46451	COIL, PMV	1	1	1	1	1
035	43T46452	VALVE, 4WAY, SHF-35B-67-04	1	1	1	1	1
036	43T46453 ^{*1}	COIL, SOLENOID, AC220V-240 50HZ	1	1	1	1	1
037	43T46454	VALVE, 2WAY, TEV-S1220DQ50	4	4	4	4	4
038	43T46411	VALVE, 2WAY, VPV-603DQ2	1	1	1	1	1
039	43T46412	VALVE, 2WAY, FDF3A06	3	3	3	2	2
040	43T46459	VALVE, 2WAY, FDF6A42	1	1	1	1	1
041	43T46460	VALVE, 2WAY, FDF11A16				1	1
042	43T46455	COIL, VALVE, 2WAY, TEV-SMOAJ2170A1	4	4	4	4	4
043	43T46403	COIL, SOLENOID, VPV-MOAJ510B0	1	1	1	1	1
044	43T46405	COIL, VALVE, 2WAY, FQ-G593	4	4	4	4	4
045	43T50357	SENSOR ASSY, LOW PRESSURE	1	1	1	1	1
046	43T50358	SENSOR ASSY, HIGH PRESSURE	1	1	1	1	1
047	43T63359	SWITCH, PRESSURE	2	2	2	2	2
048	43T57303	HEATER, CASE, 29W 240V	2	2	2	2	2
049	43T57304	HEATER, CASE, 55W 240V	1	1	1	1	1
050	43T48314	SEPARATOR	1	1	1	1	1
051	43T48308	TANK, LIQUID	1	1	1	1	1
052	43T48313	ACCUMULATOR	1	1	1	1	1
053	43T43523	CONDENSER ASSY, TWO ROW, LEFT	1	1	1		
054	43T43524	CONDENSER ASSY, TWO ROW, RIGHT	1	1	1		
055	43T43525	CONDENSER ASSY, THREE ROW, LEFT				1	1
056	43T43526	CONDENSER ASSY, THREE ROW, RIGHT				1	1

Ref. No.	Part No.	Description	Qty/Set MMY-				
			MAP0806 HT8(J)P	MAP1006 HT8(J)P	MAP1206 HT8(J)P	MAP1406 HT8(J)P	MAP1606 HT8(J)P
057	43T47388	STRAINER	5	5	5	5	5
058	43T47389	STRAINER	1	1	1	1	1
059	43T47390	STRAINER	2	2	2	1	1
060	43T47392	STRAINER				2	2
061	43T47393	STRAINER					
062	43T47394	STRAINER	1	1	1		
063	43T47395	STRAINER				1	1
064	43T49348	RUBBER, SUPPORTER, PIPE	1	1	1	2	2
065	43T49349	RUBBER, SUPPORTER, PIPE	1	1	1	6	6
066	43T49350	RUBBER, SUPPORTER, PIPE	3	3	3	1	1
067	43T49351	RUBBER, SUPPORTER, PIPE	2	2	2	5	5
068	43T49352	RUBBER, SUPPORTER, PIPE	1	1	1	3	3
069	43T49353	RUBBER, SUPPORTER, PIPE	1	1	1	3	3
070	43T49354	RUBBER, SUPPORTER, PIPE	2	2	2	2	2
071	43T49355	RUBBER, SUPPORTER, PIPE	1	1	1	2	2
072	43T49347	RUBBER, SUPPORTER, PIPE	4	4	4	4	4
073	43T49365	RUBBER, SUPPORTER, PIPE				1	1
074	43T49360	RUBBER, SUPPORTER, PIPE	2	2	2		
075	43T49358	BAND, FIX	5	5	5	8	8
076	43T19333	HOLDER, SENSOR	11	11	11	15	15
077	43T01310	MARK, TOSHIBA	1	1	1	1	1
078	43T63358	HOLDER, NFC	1	1	1	1	1
079	43T39351	NUT, FLANGE	1	1	1	1	1
080	43T39350	WASHER	1	1	1	1	1
081	43T47385	BOLT, COMPRESSOR	6	6	6	6	6
082	43T49357	RUBBER, CUSHION	6	6	6	6	6
083	43T47333	BONNET, 1/2 IN	1	1	1		
084	43T47332	BONNET, 3/8 IN	1	1	1	1	1
085	43T47334	BONNET, 5/8 IN				1	1
086	43T49338	PLUG, FUSIBLE	1	1	1	1	1
087	43T47374	TUBE, CAPILLARY, ID 0.8	1	1	1	1	1
088	43T47375	TUBE, CAPILLARY, ID 1.0	1	1	1	1	1
089	43T47376	TUBE, CAPILLARY, ID 1.2	1	1	1	1	1
090	43T85599	OWNER'S MANUAL	1	1	1	1	1

Ref. No.	Part No.	Description	Q'ty/Set MMY-		
			MAP1806 HT8(J)P	MAP2006 HT8(J)P	MAP2206 HT8(J)P
001	43T20341	FAN, PROPELLER	2	2	2
002	43T20343	MOTOR, FAN, DC530-620V, 3500L	2	2	2
003	43T19361	CABINET, AIR OUTLET	2	2	2
004					
005	43T19359	GUARD, FAN	2	2	2
006	43T00663	CABINET ASSY, SIDE, LEFT	1	1	1
007	43T00664	CABINET ASSY, SIDE, RIGHT	1	1	1
008	43T00665	CABINET, AIR INLET, FRONT	1	1	1
009	43T00666	CABINET, AIR INLET, BACK	1	1	1
010					
011	43T00622	CABINET, AIR INLET, BACK	2	2	2
012	43T00667	CABINET ASSY, FRONT, DOWN	1	1	1
013	43T00668	CABINET ASSY, BACK, DOWN	1	1	1
014	43T00669	CABINET ASSY, FRONT, DOWN	1	1	1
015	43T00618	CABINET ASSY, BACK, DOWN	1	1	1
016	43T00623	PANEL	1	1	1
017					
018	43T41485	COMPRESSOR, RA641A3TB-20M	2	2	2
019	43T46393	VALVE, BALL, 25.4	1	1	1
020	43T46456	VALVE, BALL, SBV-JA6GTC-1	1	1	1
021	43T46366	VALVE, PACKED, 9.52	1	1	1
022					
023					
024	43T46445	VALVE, CHECK, UCV-A1506DRQ5	2	2	2
025	43T46446	VALVE, CHECK, UCV-A1507DR	1	1	1
026					
027	43T46399	VALVE, CHECK, BCV-603DY	1	1	1
028	43T46400	VALVE, CHECKED, BCV-302DY	3	3	3
029	43T46409	JOINT,CHECK	3	3	3
030	43T46447	VALVE, PMV, PAM-BA2YGTF-1 (φ4.8)	1	1	1
031	43T46448	VALVE, PMV, UKV-25D100 (φ2.5)	2	2	2
032	43T46449	COIL, PMV	1	1	1
033	43T46450	COIL, PMV	1	1	1
034	43T46451	COIL, PMV	1	1	1
035	43T46452	VALVE, 4WAY, SHF-35B-67-04	1	1	1
036	43T46453 ^{*2}	COIL, SOLENOID, AC220V-240 50HZ	1	1	1
037	43T46454	VALVE, 2WAY, TEV-S1220DQ50	4	4	4
038	43T46411	VALVE, 2WAY, VPV-603DQ2	1	1	1
039	43T46412	VALVE, 2WAY, FDF3A06	2	2	2
040	43T46459	VALVE, 2WAY, FDF6A42	1	1	1
041	43T46460	VALVE, 2WAY, FDF11A16	1	1	1
042	43T46455	COIL, VALVE, 2WAY, TEV-SMOAJ2170A1	4	4	4
043	43T46403	COIL, SOLENOID, VPV-MOAJ510B0	1	1	1
044	43T46405	COIL, VALVE, 2WAY, FQ-G593	4	4	4
045	43T50357	SENSOR ASSY, LOW PRESSURE	1	1	1
046	43T50358	SENSOR ASSY, HIGH PRESSURE	1	1	1
047	43T63359	SWITCH, PRESSURE	2	2	2
048	43T57303	HEATER, CASE, 29W 240V	2	2	2
049	43T57304	HEATER, CASE, 55W 240V	1	1	1
050	43T48314	SEPARATOR	1	1	1
051	43T48309	TANK, LIQUID	1	1	1
052	43T48312	ACCUMULATOR	1	1	1
053					
054					
055	43T43527	CONDENSER ASSY, THREE ROW, LEFT	1	1	1
056	43T43528	CONDENSER ASSY, THREE ROW, RIGHT	1	1	1

			HT8(J)P	MAP2006 HT8(J)P	MAP2206 HT8(J)P
057	43T47388	STRAINER	5	5	5
058	43T47389	STRAINER	1	1	1
059	43T47390	STRAINER	1	1	1
060	43T47392	STRAINER	1	1	1
061					
062					
063	43T47395	STRAINER	1	1	1
064	43T47400	STRAINER	1	1	1
065	43T49348	RUBBER, SUPPORTER, PIPE	3	3	3
066	43T49349	RUBBER, SUPPORTER, PIPE	5	5	5
067	43T49350	RUBBER, SUPPORTER, PIPE	3	3	3
068	43T49351	RUBBER, SUPPORTER, PIPE	3	3	3
069	43T49352	RUBBER, SUPPORTER, PIPE	4	4	4
070	43T49353	RUBBER, SUPPORTER, PIPE	3	3	3
071	43T49354	RUBBER, SUPPORTER, PIPE	2	2	2
072	43T49355	RUBBER, SUPPORTER, PIPE	1	1	1
073	43T49347	RUBBER, SUPPORTER, PIPE	3	3	3
074	43T49365	RUBBER, SUPPORTER, PIPE	1	1	1
075	43T49360	RUBBER, SUPPORTER, PIPE	0	0	0
076	43T49358	BAND, FIX	7	7	7
077	43T19333	HOLDER, SENSOR	15	15	15
078	43T01310	MARK, TOSHIBA	1	1	1
079	43T63358	HOLDER, NFC	1	1	1
080	43T39351	NUT, FLANGE	2	2	2
081	43T39350	WASHER	2	2	2
082	43T47385	BOLT, COMPRESSOR	6	6	6
083	43T49357	RUBBER, CUSHION	6	6	6
084	43T47401	BONNET, 3/4 IN	1	1	1
085	43T47332	BONNET, 3/8 IN	1	1	1
086					
087	43T49338	PLUG, FUSIBLE	1	1	1
088	43T47374	TUBE, CAPILLARY, ID 0.8	1	1	1
089	43T47375	TUBE, CAPILLARY, ID 1.0	1	1	1
090	43T47376	TUBE, CAPILLARY, ID 1.2	1	1	1
091	43T85599	OWNER'S MANUAL	1	1	1

Inverter Assembly
MMY-MAP0806HT8P-E, MAP1006HT8P-E, MAP1206HT8P-E

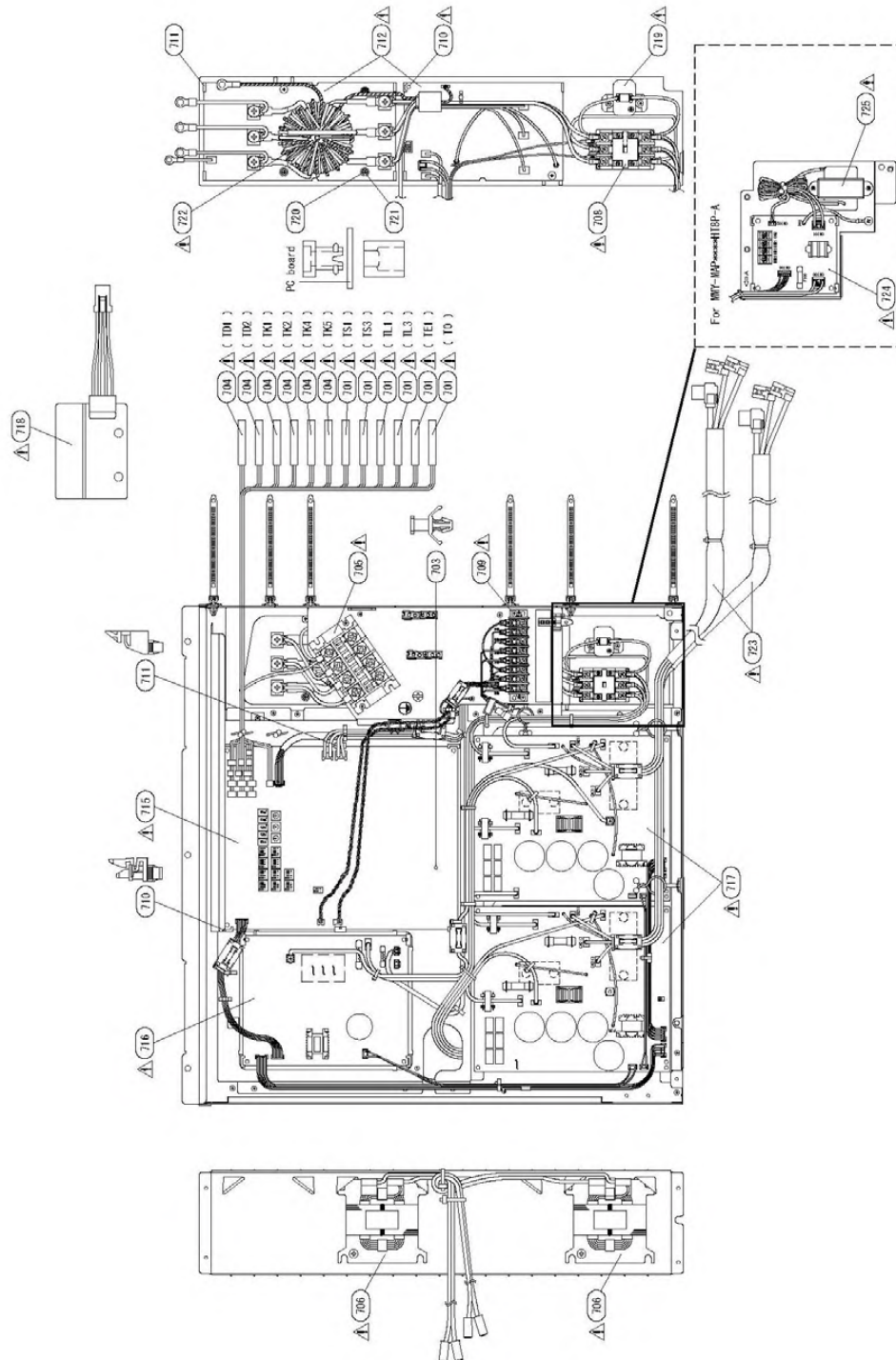

Inverter Assembly MMY-MAP1406HT8P-E, MAP1606HT8P-E

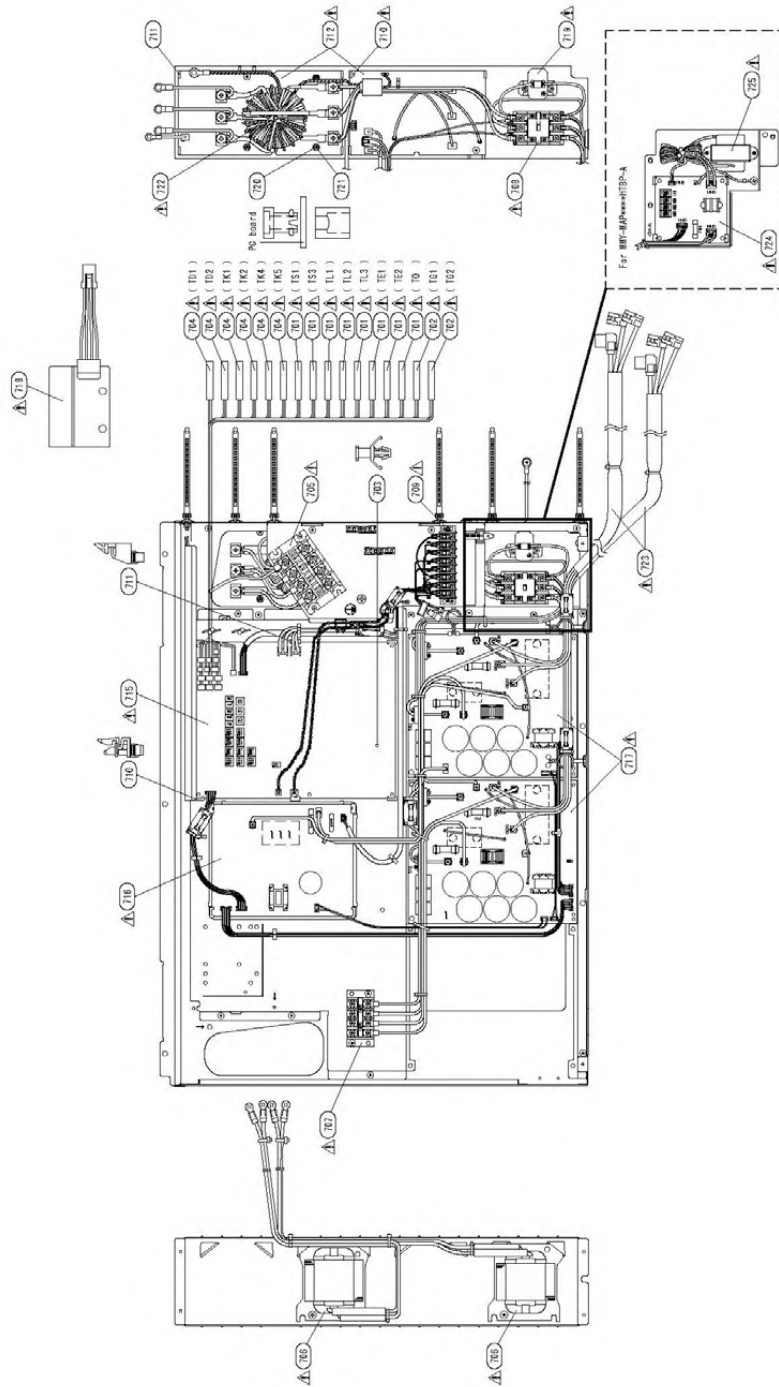

Inverter Assembly
MMY-MAP1806HT8P-E, MAP2006HT8P-E, MAP2206HT8P-E

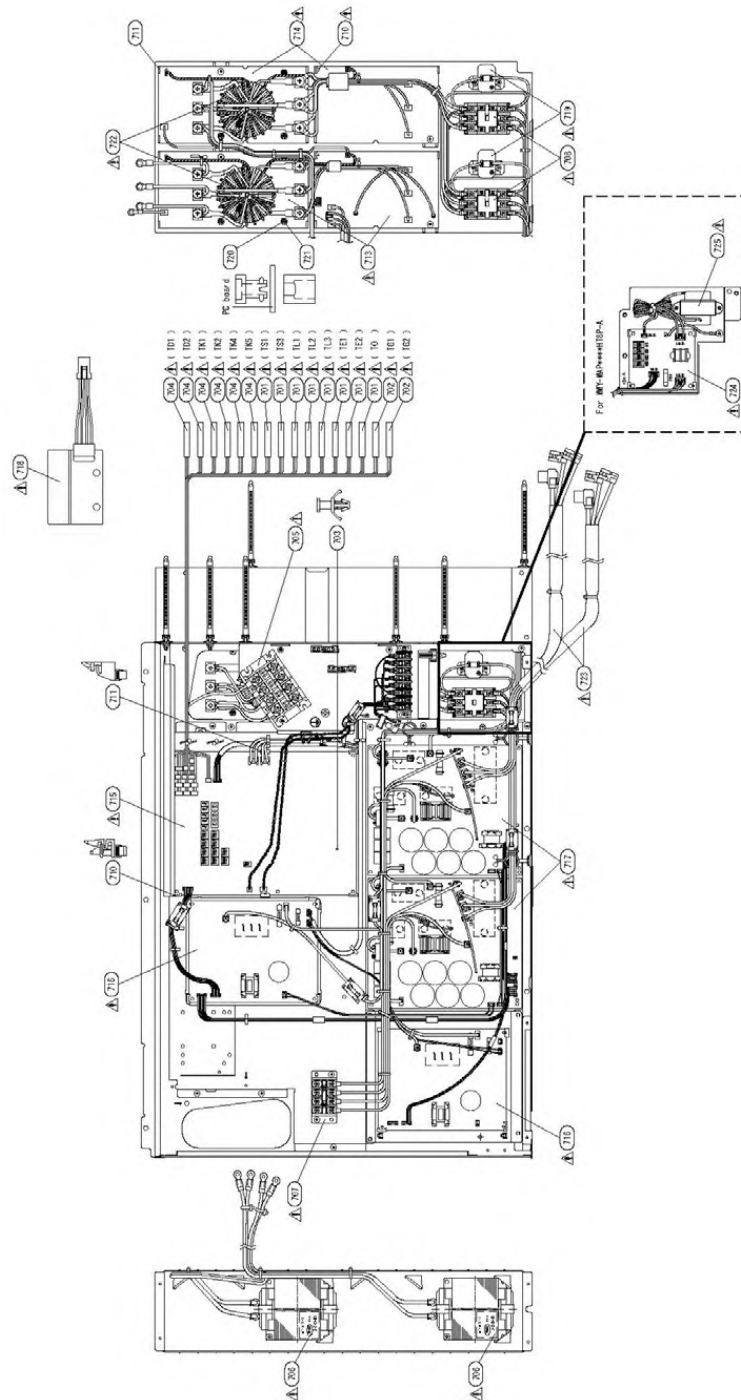

Ref. No.	Part No.	Description	Q'ty/Set MMY-				
			MAP0806 (H)T*(J)P*	MAP1006 (H)T*(J)P*	MAP1206 (H)T*(J)P*	MAP1406 (H)T*(J)P*	MAP1606 (H)T*(J)P*
701	43T50347	SENSOR ASSY, SERVICE	4	4	4	8	8
702	43T50356	SERVICE-SENSOR				2	2
703	43T95303	SUPPORTER, ASSY	3	3	3	3	3
704	43T50348	SENSOR,TD(F6)	6	6	6	6	6
705	43T60437	TERMINAL, 4P	1	1	1	1	1
706	43T58317	REACTOR, CH-79	2	2	2		
706	43T58330	REACTOR, CH-90				2	2
707	43T60453	TERMINAL, 4P				1	1
708	43T52320	CONTACTOR, MAGNETIC	1	1	1	1	1
709	43T60457	TERMINAL, 8P	1	1	1	1	1
710	43T95301	SUPPORT, SPACER	7	7	7	7	7
711	43T95302	SPACER(EDGE)	10	10	10	10	10
712	43T6V623	PC BOARD ASSY, NOISE FILTER, MCC-1608	1	1	1	1	1
715	43T6V626	PC BOARD ASSY, INTERFACE, MCC-1673	1	1	1	1	1
716	43T6V627	PC BOARD ASSY, FAN-IPDU, MCC-1659	1	1	1	1	1
717	43T6V628	PC BOARD ASSY, COMP-IPDU, MCC-1669	2	2	2		
717	43T6V629	PC BOARD ASSY, COMP-IPDU, MCC-1669				2	2
718	43T6V631	PC BOARD ASSY, NFC, MCC-1667	1	1	1	1	1
719	43T50345	THERMISTOR, PTC	1	1	1	1	1
720	43T96307	BUSHING	3	3	3	3	3
721	43T96306	COLLAR	3	3	3	3	3
722	43T55367	FILTER, LINE	1	1	1	1	1
723	43T60454	LEAD ASSY, COMPRESSOR	2	2	2		
723	43T60455	LEAD ASSY, COMPRESSOR				2	2

Ref. No.	Part No.	Description	Q'ty/Set MMY-		
			MAP1806 (H)T*(J)P*	MAP2006 (H)T*(J)P*	MAP2206 (H)T*(J)P*
701	43T50347	SENSOR ASSY, SERVICE	8	8	8
702	43T50356	SERVICE-SENSOR	2	2	2
703	43T95303	SUPPORTER, ASSY	3	3	3
704	43T50348	SENSOR,TD(F6)	6	6	6
705	43T60437	TERMINAL, 4P	1	1	1
706	43T58331	REACTOR, CH-65	2	2	2
707	43T60453	TERMINAL, 4P	1	1	1
708	43T52320	CONTACTOR, MAGNETIC	2	2	2
709	43T60457	TERMINAL, 8P	1	1	1
710	43T95301	SUPPORT, SPACER	10	10	10
711	43T95302	SPACER(EDGE)	18	18	18
713	43T6V624	PC BOARD ASSY, NOISE FILTER, MCC-1608	1	1	1
714	43T6V625	PC BOARD ASSY, NOISE FILTER, MCC-1608	1	1	1
715	43T6V626	PC BOARD ASSY, INTERFACE, MCC-1673	1	1	1
716	43T6V627	PC BOARD ASSY, FAN-IPDU, MCC-1659	2	2	2
717	43T6V630	PC BOARD ASSY, COMP-IPDU, MCC-1660	2	2	2
718	43T6V631	PC BOARD ASSY, NFC, MCC-1667	1	1	1
719	43T50345	THERMISTOR, PTC	2	2	2
720	43T96307	BUSHING	6	6	6
721	43T96306	COLLAR	6	6	6
722	43T55366	FILTER, LINE	2	2	2
723	43T60456	LEAD ASSY, COMPRESSOR	2	2	2

For T8(J)P, T8P-SG, T8(J)P-ID, T8(J)P-T model

Ref. No.	Part No.	Description	Q'ty/Set MMY-			
			MAP0806 T*(J)P	MAP1006 T*(J)P	MAP1206 T*(J)P	MAP1406 T*(J)P
701	43T50347	SENSOR ASSY, SERVICE	4	4	4	4
703	43T95303	SUPPORTER, ASSY	3	3	3	3
704	43T50348	SENSOR,TD(F6)	6	6	6	6
705	43T60437	TERMINAL, 4P	1	1	1	1
706	43T58317	REACTOR, CH-79	2	2	2	2
708	43T52320	CONTACTOR, MAGNETIC	1	1	1	1
709	43T60457	TERMINAL, 8P	1	1	1	1
710	43T95301	SUPPORT, SPACER	7	7	7	7
711	43T95302	SPACER(EDGE)	10	10	10	10
712	43T6V623	PC BOARD ASSY, NOISE FILTER, MCC-1608	1	1	1	1
715	43T6V626	PC BOARD ASSY, INTERFACE, MCC-1673	1	1	1	1
716	43T6V627	PC BOARD ASSY, FAN IPDU, MCC-1659	1	1	1	1
717	43T6V628	PC BOARD ASSY, COMP-IPDU, MCC-1669	2	2	2	2
718	43T6V631	PC BOARD ASSY, NFC, MCC-1667	1	1	1	1
719	43T50345	THERMISTOR, PTC	1	1	1	1
720	43T96307	BUSHING	3	3	3	3
721	43T96306	COLLAR	3	3	3	3
722	43T55367	FILTER, LINE	1	1	1	1
723	43T60454	LEAD ASSY, COMPRESSOR	2	2	2	2

Ref. No.	Part No.	Description	Q'ty/Set MMY-		
			MAP1406 T*(J)P	MAP1606 T*(J)P	MAP18B6 T*(J)P
701	43T50347	SENSOR ASSY, SERVICE	8	8	8
703	43T95303	SUPPORTER, ASSY	3	3	3
704	43T50348	SENSOR,TD(F6)	6	6	6
705	43T60437	TERMINAL, 4P	1	1	1
706	43T58330	REACTOR, CH-90	2	2	2
707	43T60453	TERMINAL, 4P	1	1	1
708	43T52320	CONTACTOR, MAGNETIC	1	1	1
709	43T60457	TERMINAL, 8P	1	1	1
710	43T95301	SUPPORT, SPACER	7	7	7
711	43T95302	SPACER(EDGE)	10	10	10
712	43T6V623	PC BOARD ASSY, NOISE FILTER, MCC-1608	1	1	1
715	43T6V626	PC BOARD ASSY, INTERFACE, MCC-1673	1	1	1
716	43T6V627	PC BOARD ASSY, FAN IPDU, MCC-1659	1	1	1
717	43T6V629	PC BOARD ASSY, COMP-IPDU, MCC-1669	2	2	2
718	43T6V631	PC BOARD ASSY, NFC, MCC-1667	1	1	1
719	43T50345	THERMISTOR, PTC	1	1	1
720	43T96307	BUSHING	3	3	3
721	43T96306	COLLAR	3	3	3
722	43T55367	FILTER, LINE	1	1	1
723	43T60455	LEAD ASSY, COMPRESSOR	2	2	2

Ref. No.	Part No.	Description	Q'ty/Set MMY-		
			MAP1806 T*(J)P	MAP2006 T*(J)P	MAP2206 T*(J)P
701	43T50347	SENSOR ASSY, SERVICE	8	8	8
703	43T95303	SUPPORTER, ASSY	3	3	3
704	43T50348	SENSOR,TD(F6)	6	6	6
705	43T60437	TERMINAL, 4P	1	1	1
706	43T58331	REACTOR, CH-65	2	2	2
707	43T60453	TERMINAL, 4P	1	1	1
708	43T52320	CONTACTOR, MAGNETIC	2	2	2
709	43T60457	TERMINAL, 8P	1	1	1
710	43T95301	SUPPORT, SPACER	10	10	10
711	43T95302	SPACER(EDGE)	18	18	18
713	43T6V624	PC BOARD ASSY, NOISE FILTER, MCC-1608	1	1	1
714	43T6V625	PC BOARD ASSY, NOISE FILTER, MCC-1608	1	1	1
715	43T6V626	PC BOARD ASSY, INTERFACE, MCC-1673	1	1	1
716	43T6V627	PC BOARD ASSY, FAN IPDU, MCC-1659	2	2	2
717	43T6V630	PC BOARD ASSY, COMP-IPDU, MCC-1660	2	2	2
718	43T6V631	PC BOARD ASSY, NFC, MCC-1667	1	1	1
719	43T50345	THERMISTOR, PTC	2	2	2
720	43T96307	BUSHING	6	6	6
721	43T96306	COLLAR	6	6	6
722	43T55366	FILTER, LINE	2	2	2
723	43T60456	LEAD ASSY, COMPRESSOR	2	2	2

8 EXPLODED DIAGRAM/PARTS LIST

SHRM-e OUTDOOR UNIT

MMY-MAP0806FT8(J)P-UK, MAP1006FT8(J)P-UK

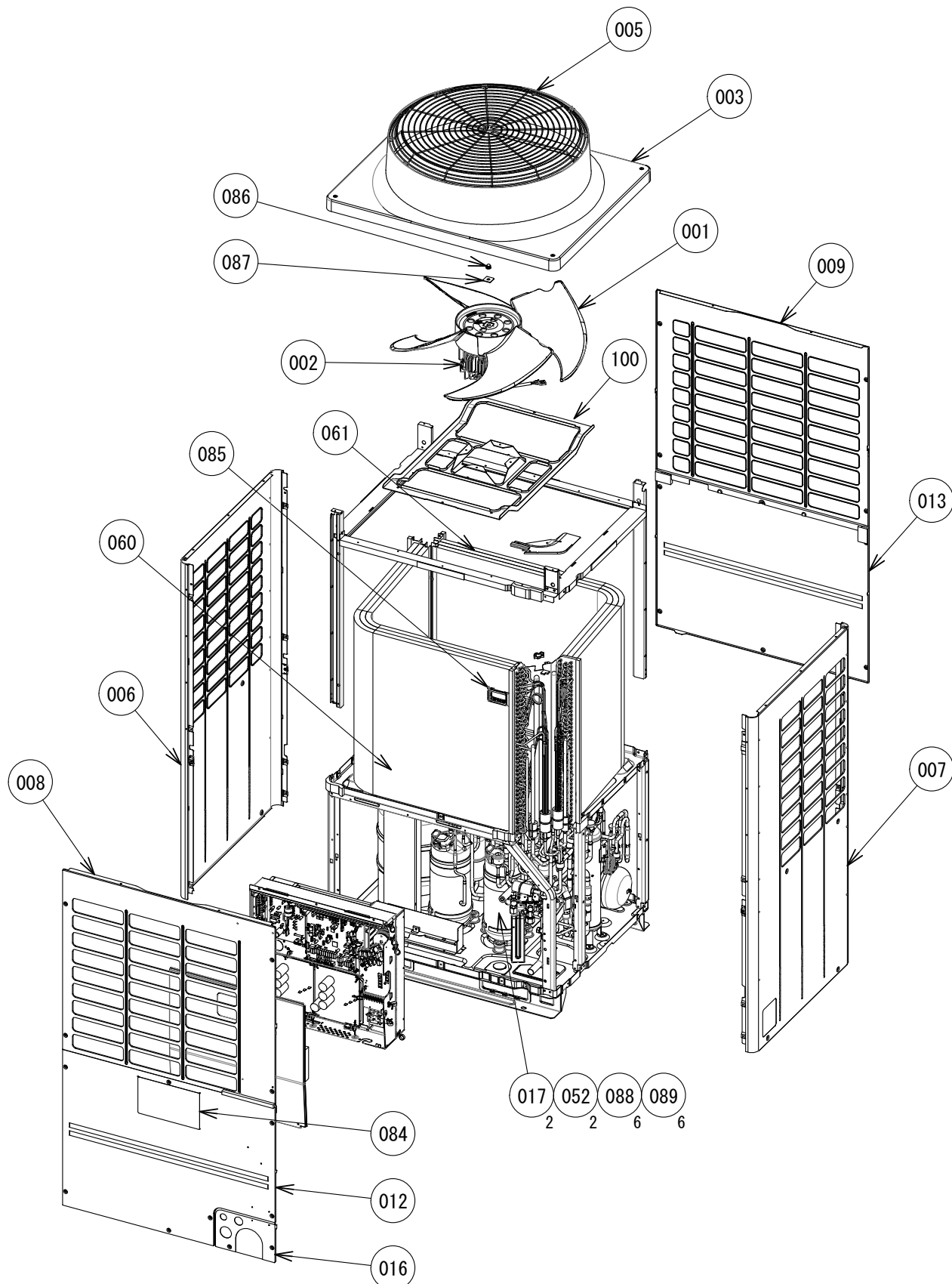

REFRIGERATION CIRCUIT DIAGRAM

MMY-MAP0806FT8(J)P-UK, MAP1006FT8(J)P-UK

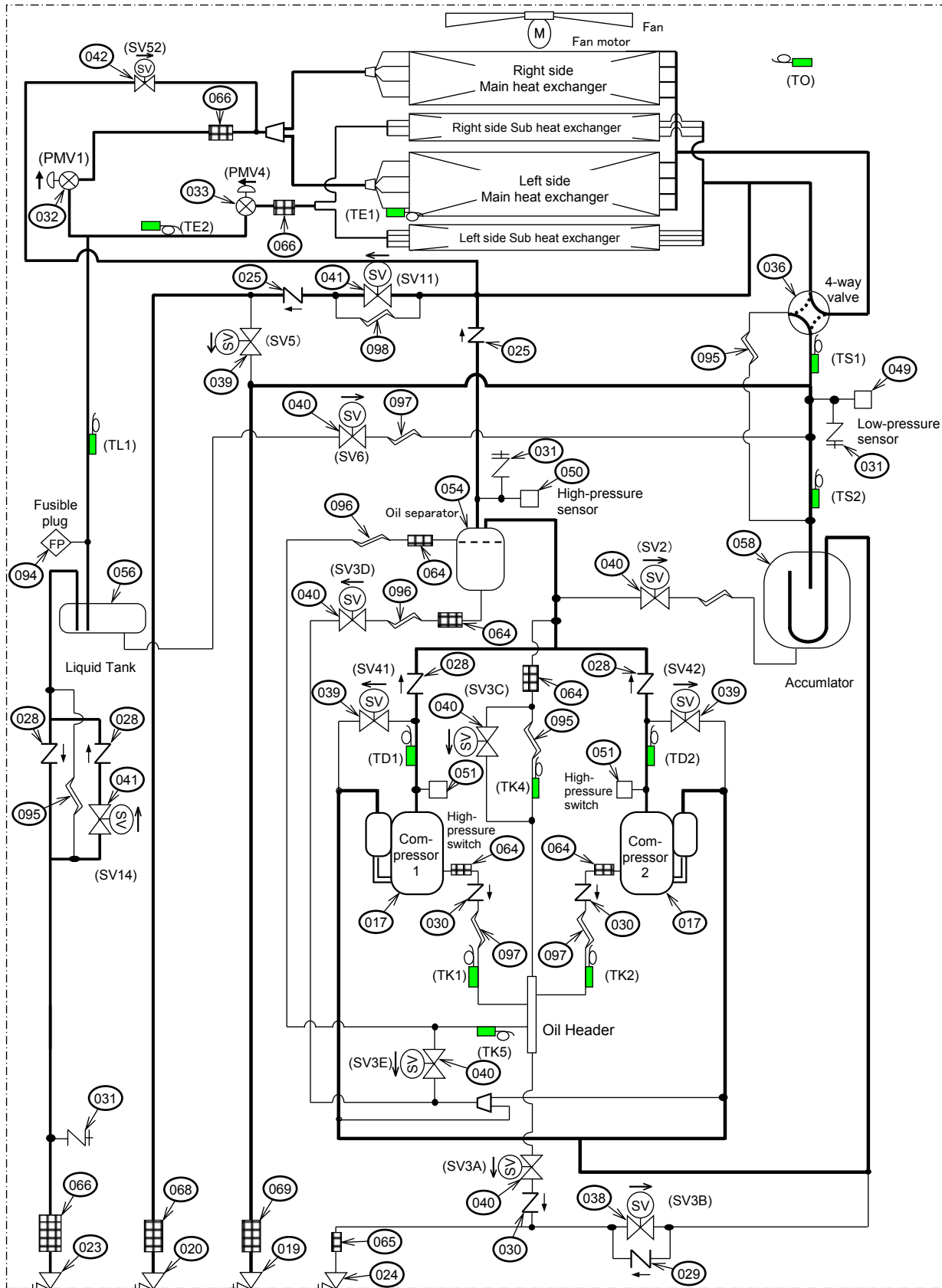

Liquid side Service valve Discharge-gas side Service valve Suction-gas side Service valve Balance pipe Service valve

Symbol						
Solenoid valve	Capillary tube	Check valve	Check joint	Strainer	Temperature sensor	Distributor

MMY-MAP1206FT8(J)P-UK, MAP1406FT8(J)P-UK

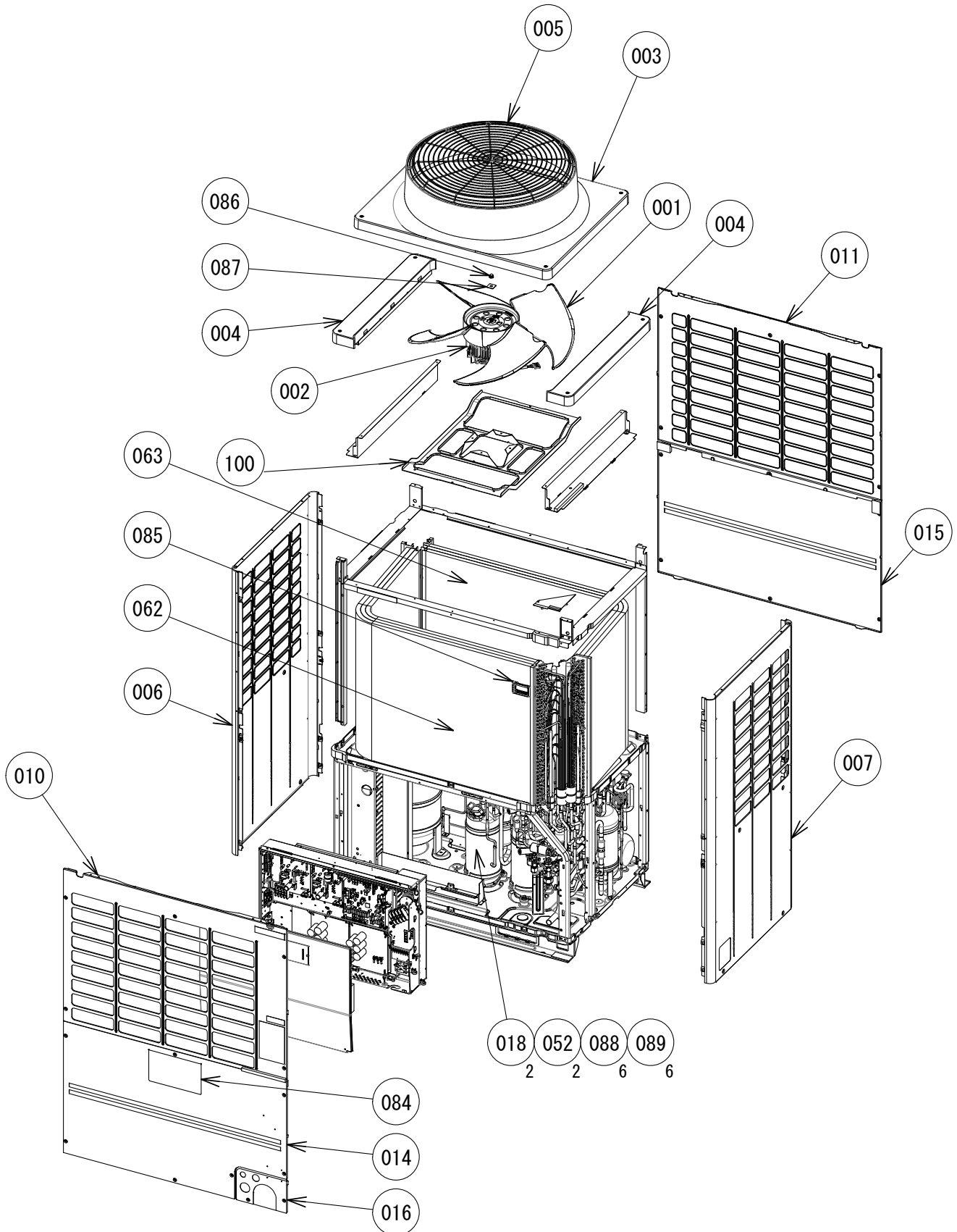

MMY-MAP1206FT8(J)P-UK, MAP1406FT8(J)P-UK

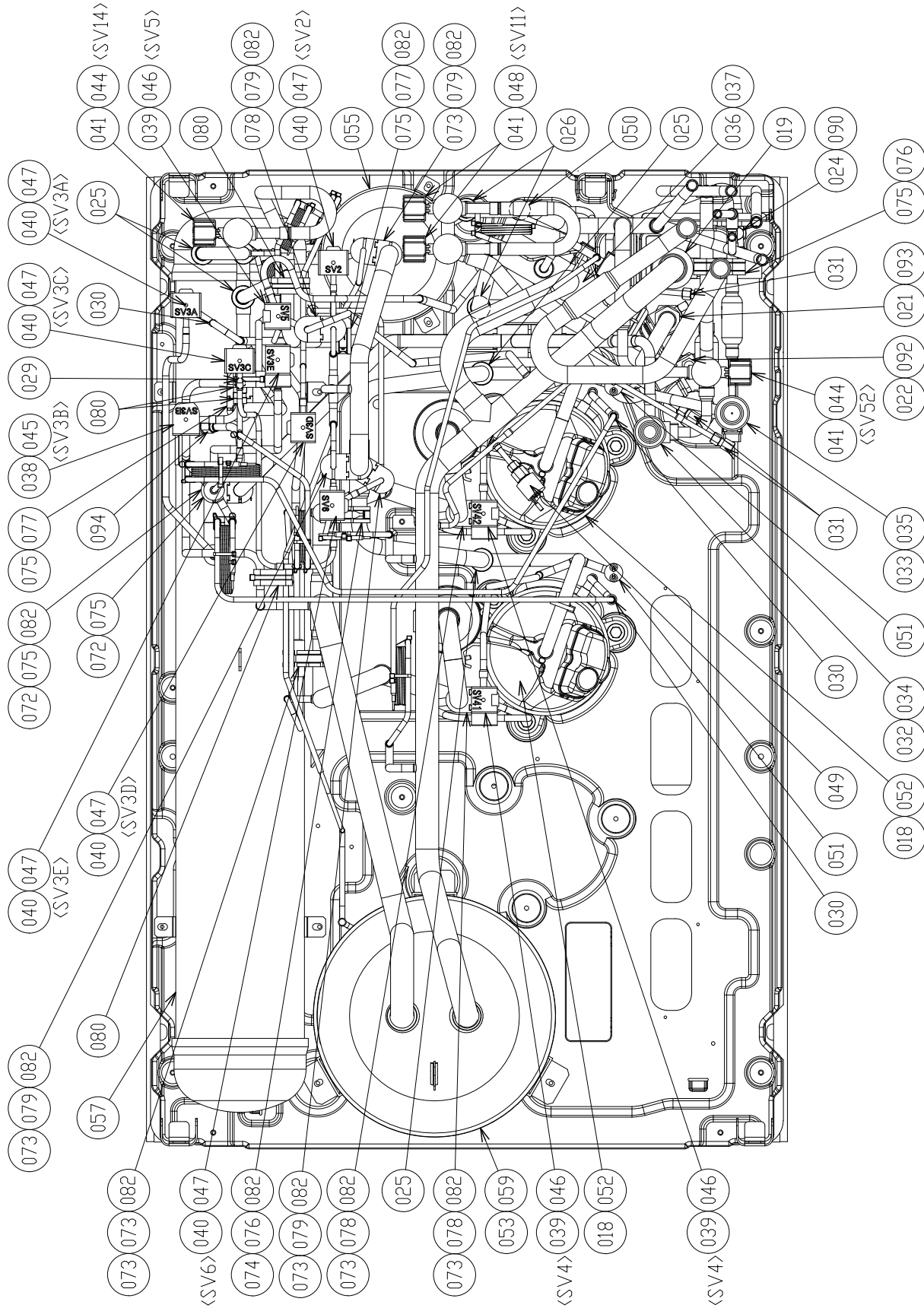

REFRIGERATION CIRCUIT DIAGRAM MMY-MAP1206FT8(J)P-UK, MAP1406FT8(J)P-UK

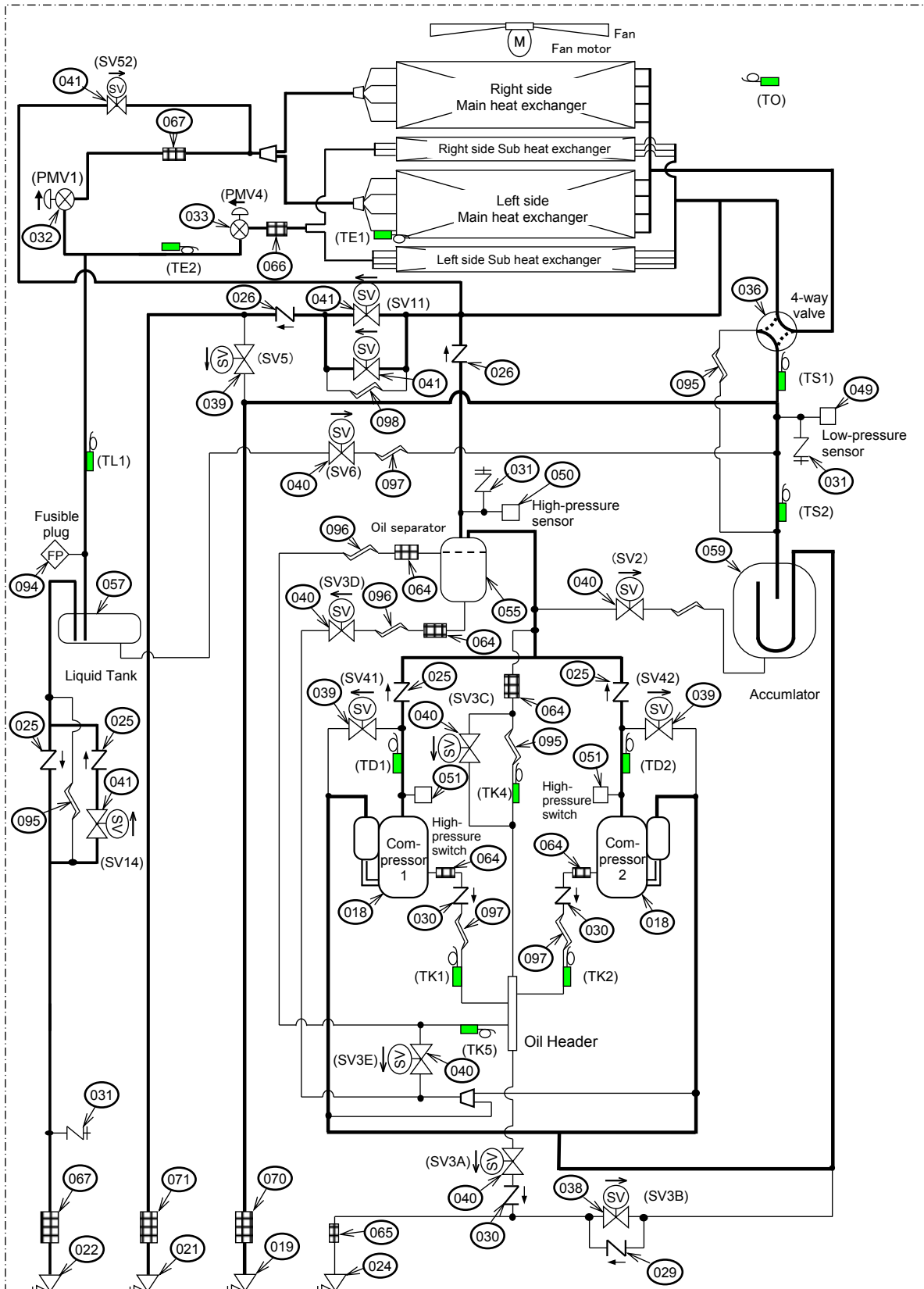

Liquid side Service valve Discharge-gas side Service valve Suction-gas side Service valve Balance pipe Service valve

Symbol						
Solenoid valve	Capillary tube	Check valve	Check joint	Strainer	Temperature sensor	Distributor

MMY-MAP1606FT8(J)P-UK, MAP1806FT8(J)P-UK, MAP2006FT8(J)P-UK

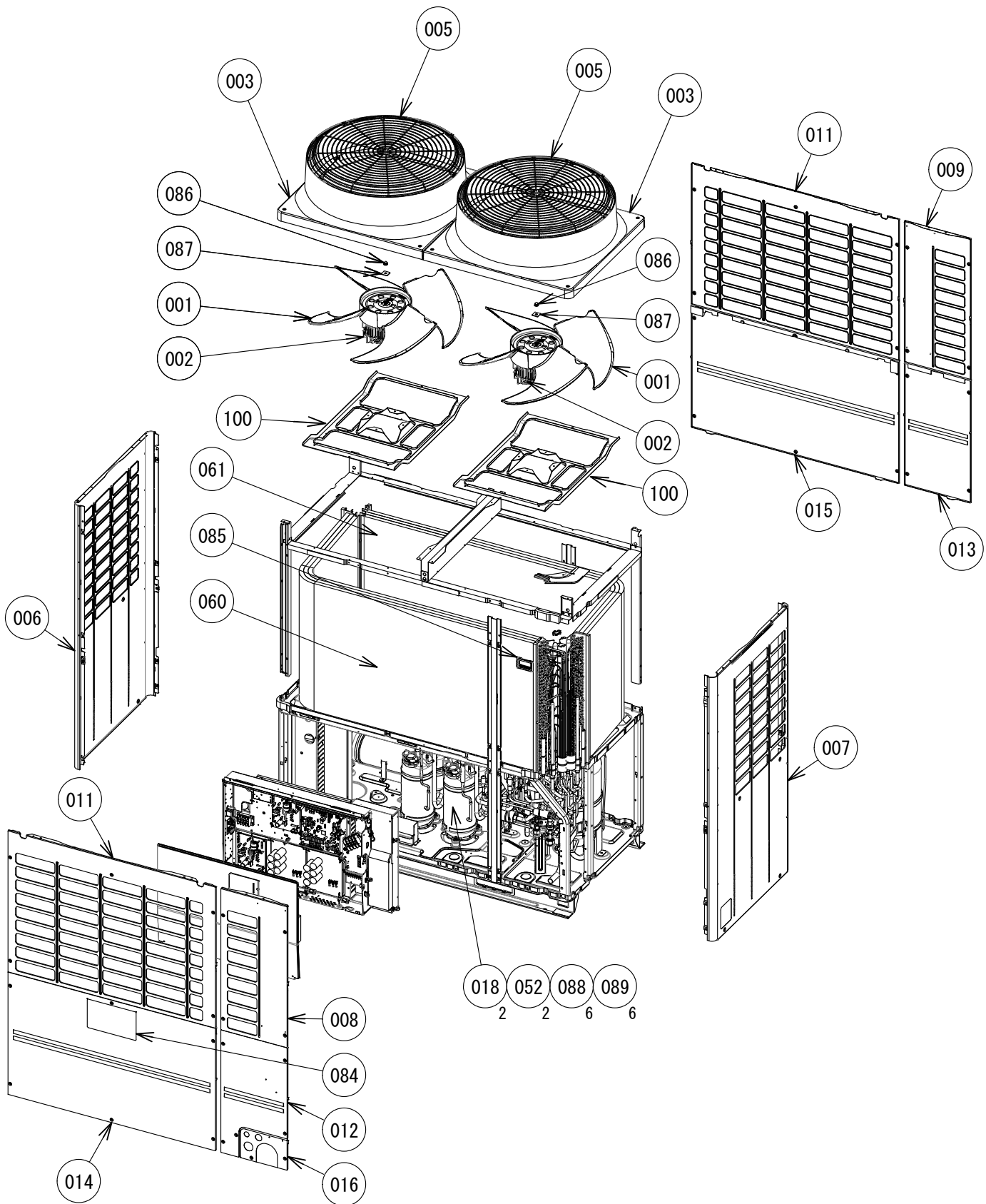

MMY-MAP1606FT8(J)P-UK, MAP1806FT8(J)P-UK, MAP2006FT8(J)P-UK

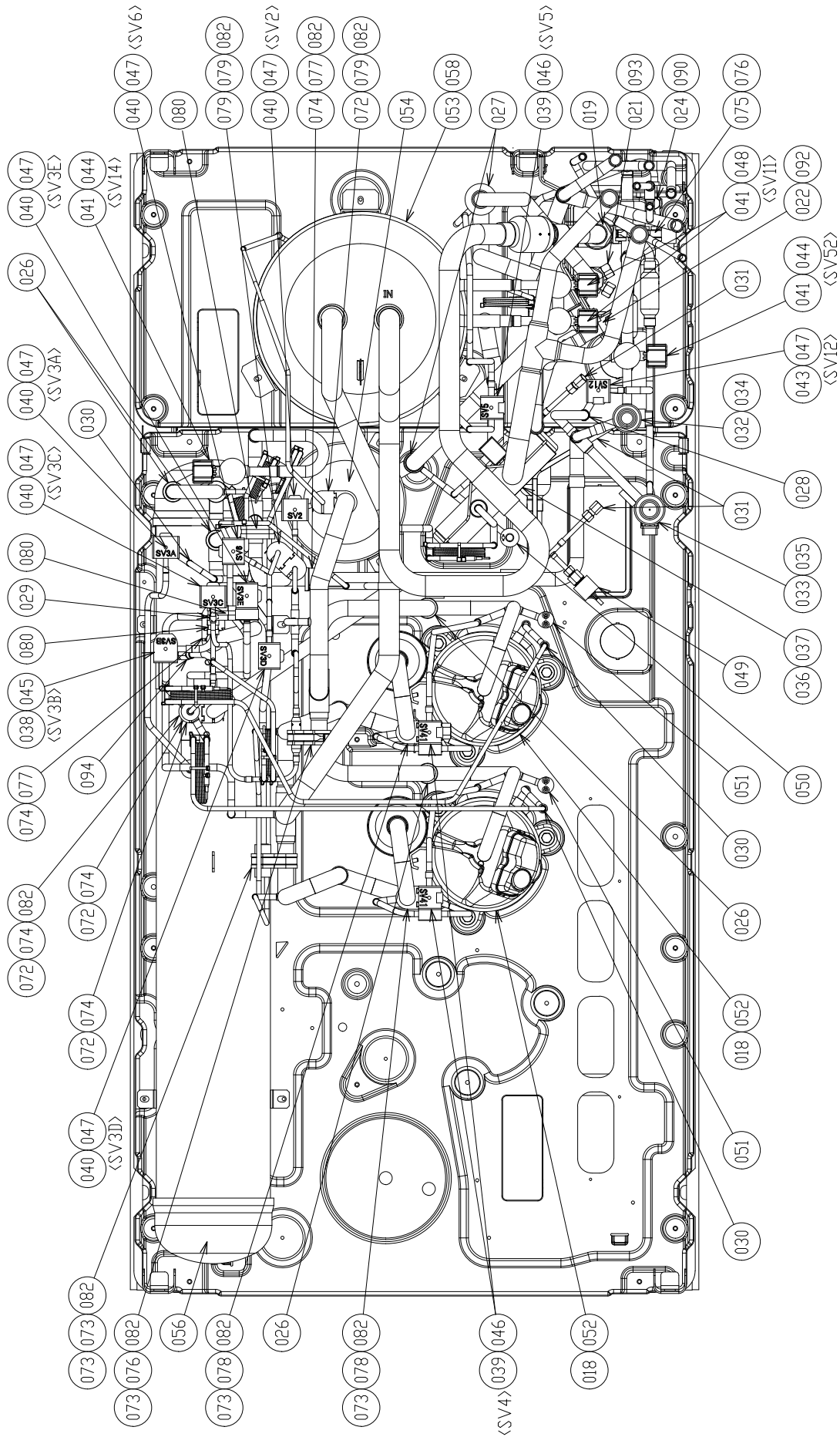

REFRIGERATION CIRCUIT DIAGRAM
MMY-MAP1606FT8(J)P-UK, MAP1806FT8(J)P-UK, MAP2006FT8(J)P-UK

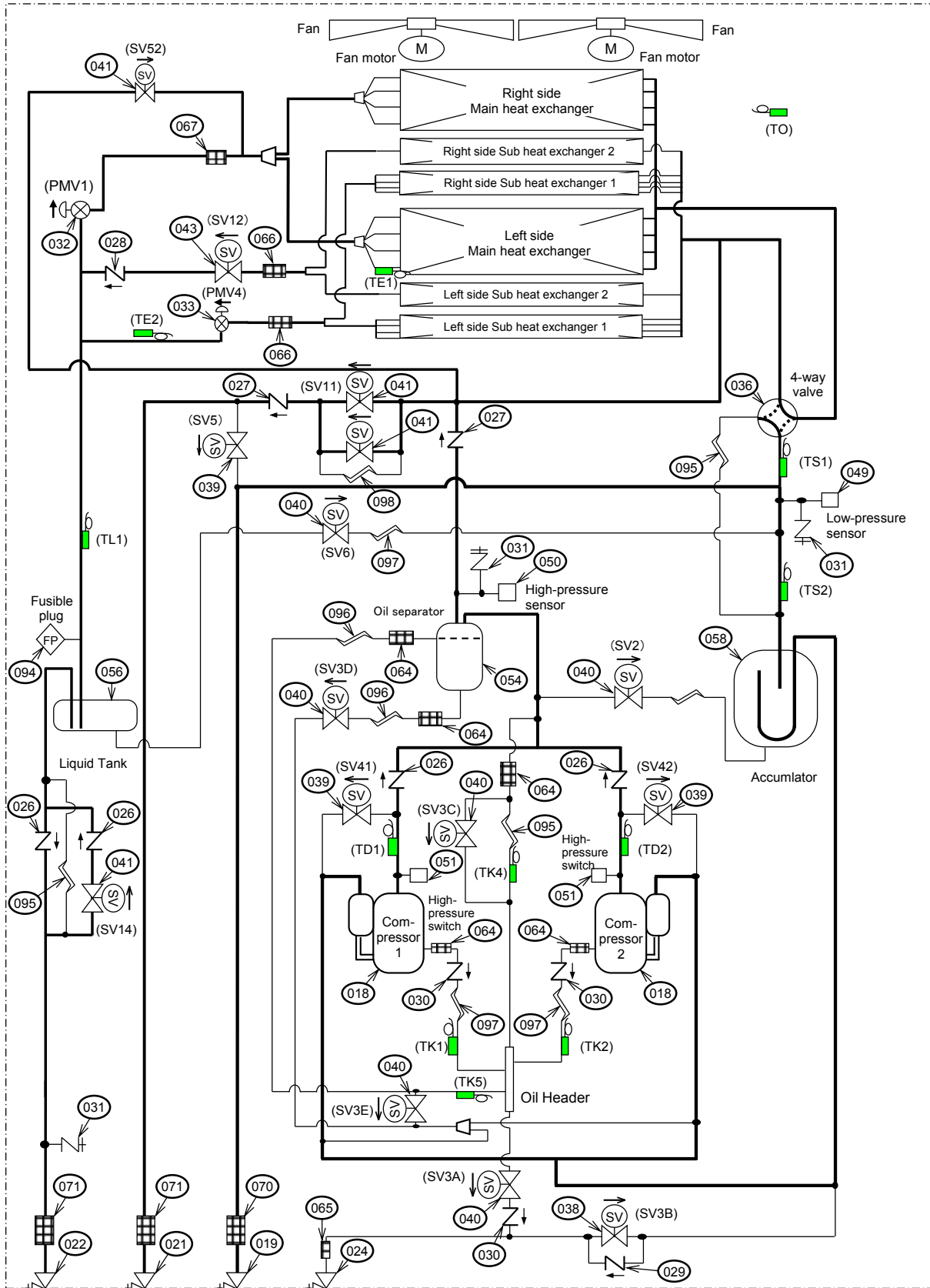

Liquid side Service valve
 Discharge-gas side Service valve
 Suction-gas side Service valve
 Balance pipe Service valve

Symbol					
Solenoid valve	Capillary tube	Check valve	Check joint	Strainer	Temperature sensor

For FT8(J)P-E, FT8(J)P-TR, FT8(J)P-UK model

Ref. No.	Part No	Description	Q'ty/Set MMY-			
			MAP0806	MAP1006	MAP1206	MAP1406
001	43T20341	FAN, PROPELLER	1	1	1	1
002	43T20342	MOTOR, FAN, DC530-620V, 2300L	1	1	1	1
003	43T19354	CABINET, AIR OUTLET	1	1	1	1
004	43T19355	CABINET, SIDE, UP			2	2
005	43T19359	GUARD, FAN	1	1	1	1
006	43T00613	CABINET ASSY, SIDE, LEFT	1	1	1	1
007	43T00614	CABINET ASSY, SIDE, RIGHT	1	1	1	1
008	43T00624	CABINET, AIR INLET, FRONT	1	1		
009	43T00620	CABINET, AIR INLET, BACK	1	1		
010	43T00625	CABINET, AIR INLET, FRONT			1	1
011	43T00622	CABINET, AIR INLET, BACK			1	1
012	43T00615	CABINET ASSY, FRONT, DOWN	1	1		
013	43T00616	CABINET ASSY, BACK, DOWN	1	1		
014	43T00617	CABINET ASSY, FRONT, DOWN			1	1
015	43T00618	CABINET ASSY, BACK, DOWN			1	1
016	43T00623	PANEL	1	1	1	1
017	43T41458	COMPRESSOR, RA421A3TB-20MD	2	2		
018	43T41485	COMPRESSOR, RA641A3TB-20M			2	2
019	43T46393	VALVE, BALL, 25.4	1	1	1	1
020	43T46381	VALVE, BALL, SBV-JA5GTC-1	1	1		
021	43T46456	VALVE, BALL, SBV-JA6GTC-1			1	1
022	43T46386	VALVE, PACKED, 15.88 DIA			1	1
023	43T46467	VALVE, PACKED, 12.7	1	1		
024	43T46366	VALVE, PACKED, 9.52	1	1	1	1
025	43T46444	VALVE, CHECK, UCV-A1505DRQ5	2	2	4	4
026	43T46445	VALVE, CHECK, UCV-A1506DRQ5			2	2
028	43T46398	VALVE, CHECKED, BCV-804DY	4	4		
029	43T46399	VALVE, CHECK, BCV-603DY	1	1	1	1
030	43T46400	VALVE, CHECKED, BCV-302DY	3	3	3	3
031	43T46409	JOINT,CHECK	3	3	3	3
032	43T46447	VALVE, PMV, PAM-BA2YGTF-1 (φ4.8)	1	1	1	1
033	43T46394	VALVE, PMV	1	1	1	1
034	43T46449	COIL, PMV	1	1	1	1
035	43T46407	COIL, PMV	1	1	1	1
036	43T46452	VALVE, 4WAY, SHF-35B-67-04	1	1	1	1
037	43T46453	COIL, SOLENOID, AC220V-240 50HZ	1	1	1	1
038	43T46411	VALVE , 2WAY, VPV-603DQ2	1	1	1	1
039	43T46412	VALVE, 2WAY, FDF3A06	3	3	3	3
040	43T46454	VALVE, 2WAY, TEV-S1220DQ50	6	6	6	6
041	43T46488	VALVE, 2WAY, VPV	2	2	4	4
042	43T46459	VALVE, 2WAY, FDF6A42	1	1		
044	43T46490	COIL, VALVE, 2WAY	1	1	2	2
045	43T46403	COIL, SOLENOID, VPV-MOAJ510B0	1	1	1	1
046	43T46405	COIL, VALVE, 2WAY, FQ-G593	4	4	3	3
047	43T46455	COIL, VALVE, 2WAY, TEV-SMOAJ2170A1	6	6	6	6
048	43T46492	COIL, VALVE, 2WAY	1	1	2	2
049	43T50357	SENSOR ASSY, LOW PRESSURE	1	1	1	1
050	43T50358	SENSOR ASSY, HIGH PRESSURE	1	1	1	1
051	43T63345	SWITCH, PRESSURE	2	2	2	2
052	43T57303	HEATER, CASE, 29W 240V	2	2	2	2
053	43T57304	HEATER, CASE, 55W 240V	1	1	1	1
054	43T48314	SEPARATOR	1	1		
055	43T48307	SEPARATOR			1	1
056	43T48317	TANK, LIQUID	1	1		

Ref. No.	Part No	Description	Q'ty/Set		MMY-	
			MAP0806	MAP1006	MAP1206	MAP1406
057	43T48318	TANK, LIQUID			1	1
058	43T48313	ACCUMULATOR	1	1		
059	43T48312	ACCUMULATOR			1	1
060	43T43531	CONDENSER ASSY, THREE ROW, LEFT	1	1		
061	43T43532	CONDENSER ASSY, THREE ROW, RIGHT	1	1		
062	43T43533	CONDENSER ASSY, THREE ROW, LEFT			1	1
063	43T43534	CONDENSER ASSY, THREE ROW, RIGHT			1	1
064	43T47388	STRAINER	5	5	5	5
065	43T47389	STRAINER	1	1	1	1
066	43T47390	STRAINER	3	3	1	1
067	43T47392	STRAINER			2	2
068	43T47393	STRAINER	1	1		
069	43T47394	STRAINER	1	1		
070	43T47395	STRAINER			1	1
071	43T47400	STRAINER			1	1
072	43T49348	RUBBER, SUPPORTER, PIPE	1	1	2	2
073	43T49349	RUBBER, SUPPORTER, PIPE	1	1	7	7
074	43T49350	RUBBER, SUPPORTER, PIPE	4	4	1	1
075	43T49351	RUBBER, SUPPORTER, PIPE	1	1	5	5
076	43T49352	RUBBER, SUPPORTER, PIPE	1	1	2	2
077	43T49353	RUBBER, SUPPORTER, PIPE			2	2
078	43T49354	RUBBER, SUPPORTER, PIPE	2	2	3	3
079	43T49355	RUBBER, SUPPORTER, PIPE	2	2	4	4
080	43T49347	RUBBER, SUPPORTER, PIPE	4	4	4	4
081	43T49360	RUBBER, SUPPORTER, PIPE	2	2		
082	43T49358	BAND, FIX	6	6	10	10
083	43T19333	HOLDER, SENSOR	12	12	12	12
084	43T01311	MARK, TOSHIBA	1	1	1	1
085	43T63358	HOLDER, NFC	1	1	1	1
086	43T39351	NUT, FLANGE	1	1	1	1
087	43T39350	WASHER	1	1	1	1
088	43T47385	BOLT, COMPRESSOR	6	6	6	6
089	43T49357	RUBBER, CUSHION	6	6	6	6
090	43T47332	BONNET, 3/8 IN	1	1	1	1
091	43T47333	BONNET, 1/2 IN	1	1		
092	43T47334	BONNET, 5/8 IN	1	1	1	1
093	43T47401	BONNET, 3/4 IN			1	1
094	43T49338	PLUG, FUSIBLE	1	1	1	1
095	43T47374	TUBE, CAPILLARY, ID 0.8	1	1	1	1
096	43T47375	TUBE, CAPILLARY, ID 1.0	1	1	1	1
097	43T47376	TUBE, CAPILLARY, ID 1.2	1	1	1	1
098	43T47406	TUBE, CAPILLARY, ID 1.5	1	1	1	1
099	43T85611 *1	OWNER'S MANUAL	1	1	1	1
	43T85612 *2					
	43T85662 *3					
100	43T00700	MOTOR, BASE	1	1	1	1

*1) For FT8(J)P-E model

*2) For FT8(J)P-TR model

*3) For FT8(J)P-UK model

Ref. No.	Part No	Description	Q'ty/Set MMY-		
			MAP1606	MAP1806	MAP2006
001	43T20341	FAN, PROPELLER	2	2	2
002	43T20343	MOTOR, FAN, DC530-620V, 3500L	2	2	2
003	43T19361	CABINET, AIR OUTLET	2	2	2
005	43T19359	GUARD, FAN	2	2	2
006	43T00663	CABINET ASSY, SIDE, LEFT	1	1	1
007	43T00664	CABINET ASSY, SIDE, RIGHT	1	1	1
008	43T00665	CABINET, AIR INLET, FRONT	1	1	1
009	43T00666	CABINET, AIR INLET, BACK	1	1	1
011	43T00622	CABINET, AIR INLET, BACK	2	2	2
012	43T00667	CABINET ASSY, FRONT, DOWN	1	1	1
013	43T00668	CABINET ASSY, BACK, DOWN	1	1	1
014	43T00669	CABINET ASSY, FRONT, DOWN	1	1	1
015	43T00618	CABINET ASSY, BACK, DOWN	1	1	1
016	43T00623	PANEL	1	1	1
018	43T41485	COMPRESSOR, RA641A3TB-20M	2	2	2
019	43T46393	VALVE, BALL, 25.4	1	1	1
021	43T46456	VALVE, BALL, SBV-JA6GTC-1	1	1	1
022	43T46386	VALVE, PACKED, 15.88 DIA	1	1	1
024	43T46366	VALVE, PACKED, 9.52	1	1	1
026	43T46445	VALVE, CHECK, UCV-A1506DRQ5	4	4	4
027	43T46446	VALVE, CHECK, UCV-A1507DR	2	2	2
028	43T46398	VALVE, CHECKED, BCV-804DY	1	1	1
029	43T46399	VALVE, CHECK, BCV-603DY	1	1	1
030	43T46400	VALVE, CHECKED, BCV-302DY	3	3	3
031	43T46409	JOINT,CHECK	3	3	3
032	43T46447	VALVE, PMV, PAM-BA2YGTF-1 (φ4.8)	1	1	1
033	43T46394	VALVE, PMV	1	1	1
034	43T46449	COIL, PMV	1	1	1
035	43T46407	COIL, PMV	1	1	1
036	43T46452	VALVE, 4WAY, SHF-35B-67-04	1	1	1
037	43T46453	COIL, SOLENOID, AC220V-240 50HZ	1	1	1
038	43T46411	VALVE , 2WAY, VPV-603DQ2	1	1	1
039	43T46412	VALVE, 2WAY, FDF3A06	3	3	3
040	43T46454	VALVE, 2WAY, TEV-S1220DQ50	6	6	6
041	43T46488	VALVE, 2WAY, VPV	4	4	4
043	43T46468	VALVE, 2WAY, TEV-S1920D	1	1	1
044	43T46490	COIL, VALVE, 2WAY	2	2	2
045	43T46403	COIL, SOLENOID, VPV-MOAJ510B0	1	1	1
046	43T46405	COIL, VALVE, 2WAY, FQ-G593	3	3	3
047	43T46455	COIL, VALVE, 2WAY, TEV-SMOAJ2170A1	7	7	7
048	43T46492	COIL, VALVE, 2WAY	2	2	2
049	43T50357	SENSOR ASSY, LOW PRESSURE	1	1	1
050	43T50358	SENSOR ASSY, HIGH PRESSURE	1	1	1
051	43T63345	SWITCH, PRESSURE	2	2	2
052	43T57303	HEATER, CASE, 29W 240V	2	2	2
053	43T57304	HEATER, CASE, 55W 240V	1	1	1
054	43T48307	SEPARATOR	1	1	1
056	43T48318	TANK, LIQUID	1	1	1

Ref. No.	Part No	Description	Q'ty/Set MMY-		
			MAP1606	MAP1806	MAP2006
058	43T48312	ACCUMULATOR	1	1	1
060	43T43535	CONDENSER ASSY, THREE ROW, LEFT	1	1	1
061	43T43536	CONDENSER ASSY, THREE ROW, RIGHT	1	1	1
064	43T47388	STRAINER	5	5	5
065	43T47389	STRAINER	1	1	1
066	43T47390	STRAINER	2	2	2
067	43T47392	STRAINER	1	1	1
070	43T47395	STRAINER	1	1	1
071	43T47400	STRAINER	2	2	2
072	43T49348	RUBBER, SUPPORTER, PIPE	4	4	4
073	43T49349	RUBBER, SUPPORTER, PIPE	5	5	5
074	43T49350	RUBBER, SUPPORTER, PIPE	5	5	5
075	43T49351	RUBBER, SUPPORTER, PIPE	1	1	1
076	43T49352	RUBBER, SUPPORTER, PIPE	2	2	2
077	43T49353	RUBBER, SUPPORTER, PIPE	2	2	2
078	43T49354	RUBBER, SUPPORTER, PIPE	2	2	2
079	43T49355	RUBBER, SUPPORTER, PIPE	3	3	3
080	43T49347	RUBBER, SUPPORTER, PIPE	3	3	3
082	43T49358	BAND, FIX	9	9	9
083	43T19333	HOLDER, SENSOR	12	12	12
084	43T01311	MARK, TOSHIBA	1	1	1
085	43T63358	HOLDER, NFC	1	1	1
086	43T39351	NUT, FLANGE	2	2	2
087	43T39350	WASHER	2	2	2
088	43T47385	BOLT, COMPRESSOR	6	6	6
089	43T49357	RUBBER, CUSHION	6	6	6
090	43T47332	BONNET, 3/8 IN	1	1	1
092	43T47334	BONNET, 5/8 IN	1	1	1
093	43T47401	BONNET, 3/4 IN	1	1	1
094	43T49338	PLUG, FUSIBLE	1	1	1
095	43T47374	TUBE, CAPILLARY, ID 0.8	1	1	1
096	43T47375	TUBE, CAPILLARY, ID 1.0	1	1	1
097	43T47376	TUBE, CAPILLARY, ID 1.2	1	1	1
098	43T47406	TUBE, CAPILLARY, ID 1.5	1	1	1
099	43T85611 *1	OWNER'S MANUAL	1	1	1
	43T85612 *2				
	43T85662 *3				
100	43T00700	MOTOR, BASE	2	2	2

*1) For FT8(J)P-E model

*2) For FT8(J)P-TR model

*3) For FT8(J)P-UK model

Inverter Assembly

MMY-MAP0806FT8(J)P-UK, MAP1006FT8(J)P-UK

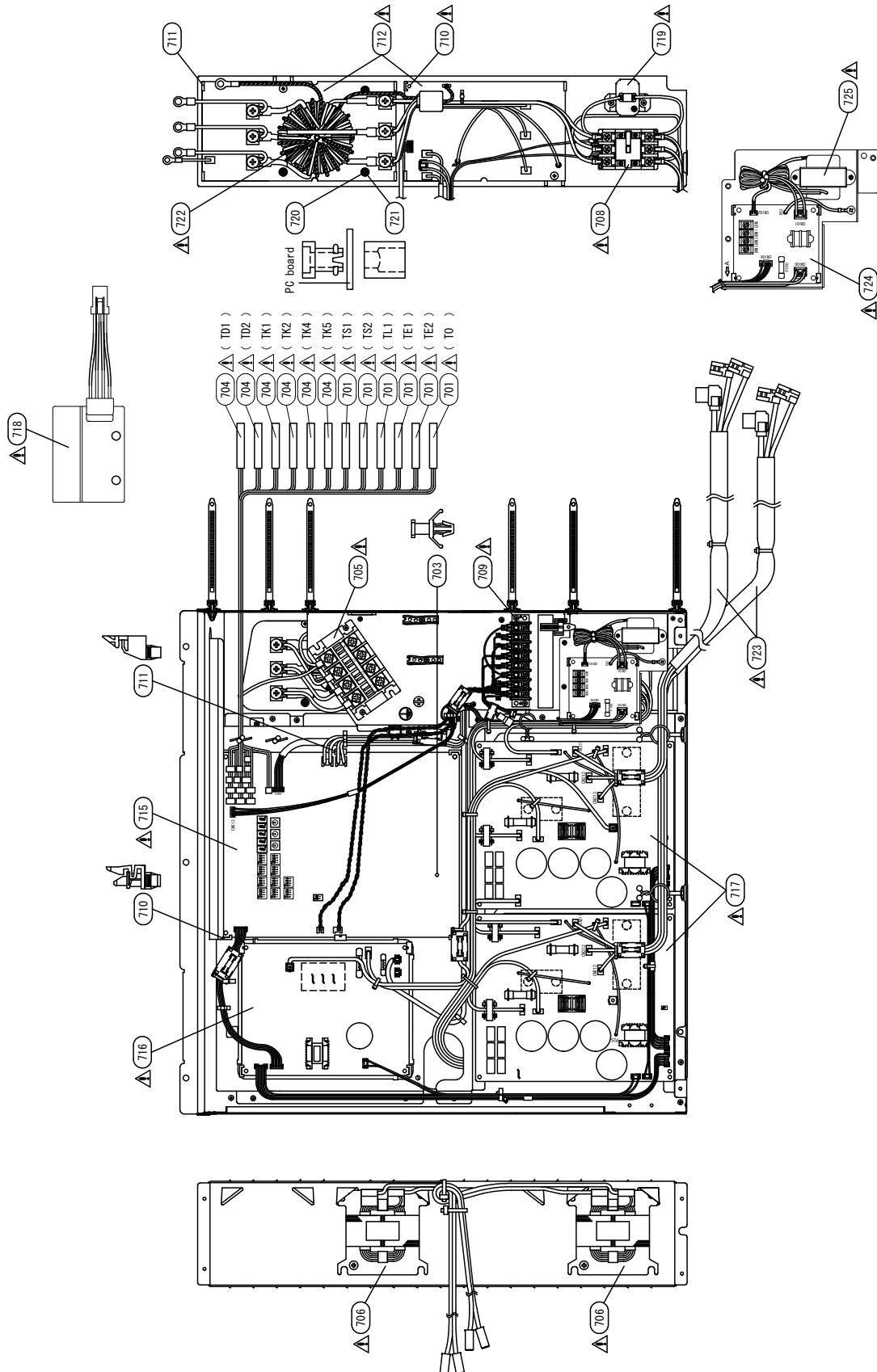

MMY-MAP1606FT8(J)P-UK, MAP1806FT8(J)P-UK, MAP2006FT8(J)P-UK

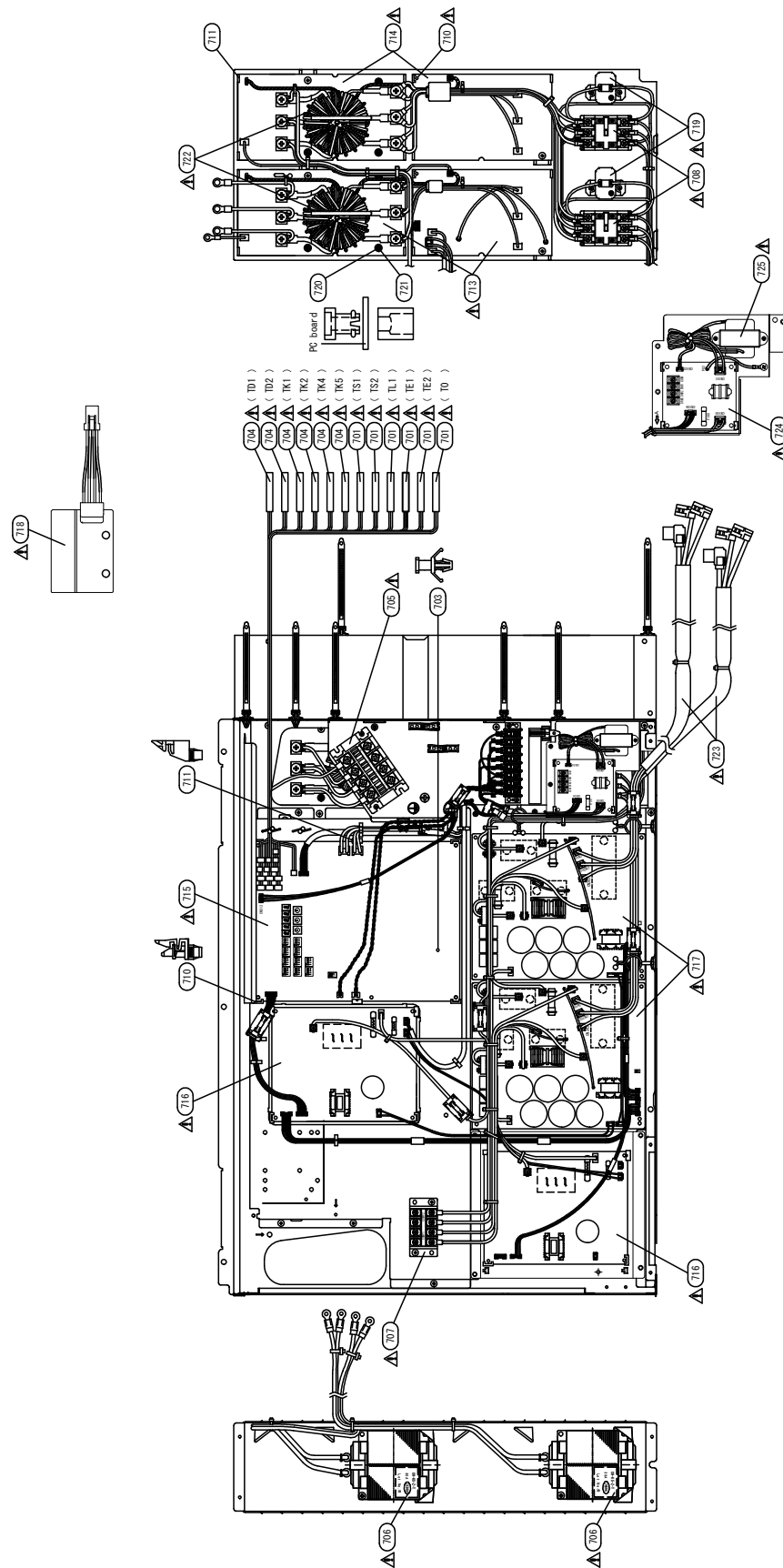

Ref. No.	Part No	Description	Q'ty/Set MMY-			
			MAP0806	MAP1006	MAP1206	MAP1406
701	43T50347	SENSOR ASSY, SERVICE	6	6	6	6
703	43T95303	SUPPORTER, ASSY	3	3	3	3
704	43T50348	SENSOR,TD(F6)	6	6	6	6
705	43T60437	TERMINAL, 4P	1	1	1	1
706	43T58317	REACTOR, CH-79	2	2		
	43T58330	REACTOR, CH-90			2	2
707	43T60453	TERMINAL, 4P			1	1
708	43T52320	CONTACTOR, MAGNETIC	1	1	1	1
709	43T60457	TERMINAL, 8P	1	1	1	1
710	43T95301	SUPPORT, SPACER	7	7	7	7
711	43T95302	SPACER(EDGE)	10	10	10	10
712	43T6V623	PC BOARD ASSY, NOISE FILTER, MCC-1608	1	1	1	1
715	43T6W386	PC BOARD ASSY, INTERFACE, MCC-1673	1	1	1	1
716	43T6V627	PC BOARD ASSY, FAN IPDU, MCC-1659	1	1	1	1
717	43T6V628	PC BOARD ASSY, COMP-IPDU, MCC-1669	2	2		
	43T6V629	PC BOARD ASSY, COMP-IPDU, MCC-1669			2	2
718	43T6V631	PC BOARD ASSY, NFC, MCC-1667	1	1	1	1
719	43T50345	THERMISTOR, PTC	1	1	1	1
720	43T96307	BUSHING	3	3	3	3
721	43T96306	COLLAR	3	3	3	3
722	43T55367	FILTER, LINE	1	1	1	1
723	43T60466	LEAD ASSY, COMPRESSOR	2	2		
	43T60467	LEAD ASSY, COMPRESSOR			2	2
724	42T6V646 *1	PC BOARD ASSY, DRC BOARD, MCC-1653	1	1	1	1
725	43T58323	TRANSFORMER (V-02 VRK)	1	1	1	1

*1) For FT8P-A model

Ref. No.	Part No	Description	Q'ty/Set		
			MAP1606	MAP1806	MMY- MAP2006
701	43T50347	SENSOR ASSY, SERVICE	6	6	6
703	43T95303	SUPPORTER, ASSY	3	3	3
704	43T50348	SENSOR,TD(F6)	6	6	6
705	43T60437	TERMINAL, 4P	1	1	1
706	43T58331	REACTOR, CH-65	2	2	2
707	43T60453	TERMINAL, 4P	1	1	1
708	43T52320	CONTACTOR, MAGNETIC	2	2	2
709	43T60457	TERMINAL, 8P	1	1	1
710	43T95301	SUPPORT, SPACER	10	10	10
711	43T95302	SPACER(EDGE)	18	18	18
713	43T6V624	PC BOARD ASSY, NOISE FILTER, MCC-1608	1	1	1
714	43T6V625	PC BOARD ASSY, NOISE FILTER, MCC-1608	1	1	1
715	43T6W386	PC BOARD ASSY, INTERFACE, MCC-1673	1	1	1
716	43T6V627	PC BOARD ASSY, FAN IPDU, MCC-1659	2	2	2
717	43T6V630	PC BOARD ASSY, COMP-IPDU, MCC-1660	2	2	2
718	43T6V631	PC BOARD ASSY, NFC, MCC-1667	1	1	1
719	43T50345	THERMISTOR, PTC	2	2	2
720	43T96307	BUSHING	6	6	6
721	43T96306	COLLAR	6	6	6
722	43T55366	FILTER, LINE	2	2	2
723	43T60468	LEAD ASSY, COMPRESSOR	2	2	2
724	42T6V646 *1	PC BOARD ASSY, DRC BOARD, MCC-1653	1	1	1
725	43T58323	TRANSFORMER (V-02 VRK)	1	1	1

*1) For FT8P-A model

TOSHIBA



Office Locations

Leatherhead

Toshiba Air Conditioning
United Technologies House
Guildford Road
Leatherhead
Surrey
KT22 9UT

Tel: 01372 220 240

marketing.uk@toshiba-ac.com

Manchester

Toshiba Air Conditioning
Unit 15 S:Park Business Park
Hamilton Road
Stockport
Greater Manchester
SK1 2AE

Tel: 0870 843 0333

sales.support@toshiba-ac.com

Plymouth

Toshiba Carrier UK Limited
Porsham Close
Belliver Industrial Estate
Plymouth
Devon
PL6 7DB

Tel: 0870 843 0333

sales.support@toshiba-ac.com

Departmental Contact Details

Sales

0845 850 8924
sales.support@toshiba-ac.com

Spares

0870 843 0333 opt 3
spares@toshiba-ac.com

Training

0870 843 0333 opt 5
toshiba.training@toshiba-ac.com

Projects

01372 220 266
projects.uk@toshiba-ac.com

Warranty

0870 843 0333 opt 6
warranty@toshiba-ac.com

Technical

0845 850 8924 opt 7
technical.enquiries@toshiba-ac.com

www.toshiba-aircon.co.uk



Toshiba Air Conditioning offering total HVAC Solutions