

## AIR CONDITIONER (MULTI TYPE)

# SERVICE MANUAL

### Indoor unit

#### <Compact 4-way cassette type>

MMU-UP0051MH-E(TR)  
MMU-UP0071MH-E(TR)  
MMU-UP0091MH-E(TR)  
MMU-UP0121MH-E(TR)  
MMU-UP0151MH-E(TR)  
MMU-UP0181MH-E(TR)

#### <2-way cassette type>

MMU-UP0071WH-E(TR)  
MMU-UP0091WH-E(TR)  
MMU-UP0121WH-E(TR)  
MMU-UP0151WH-E(TR)  
MMU-UP0181WH-E(TR)  
MMU-UP0241WH-E(TR)  
MMU-UP0271WH-E(TR)  
MMU-UP0301WH-E(TR)  
MMU-UP0361WH-E(TR)  
MMU-UP0481WH-E(TR)  
MMU-UP0561WH-E(TR)

#### <1-way cassette type>

MMU-UP0151SH-E(TR)  
MMU-UP0181SH-E(TR)  
MMU-UP0241SH-E(TR)

#### <Floor standing cabinet type>

MML-UP0071H-E(TR)  
MML-UP0091H-E(TR)  
MML-UP0121H-E(TR)  
MML-UP0151H-E(TR)  
MML-UP0181H-E(TR)  
MML-UP0241H-E(TR)

#### <Floor standing concealed type>

MML-UP0071BH-E(TR)  
MML-UP0091BH-E(TR)  
MML-UP0121BH-E(TR)  
MML-UP0151BH-E(TR)  
MML-UP0181BH-E(TR)  
MML-UP0241BH-E(TR)

#### <Floor standing type>

MMF-UP0151H-E(TR)  
MMF-UP0181H-E(TR)  
MMF-UP0241H-E(TR)  
MMF-UP0271H-E(TR)  
MMF-UP0361H-E(TR)  
MMF-UP0481H-E(TR)  
MMF-UP0561H-E(TR)

# CONTENTS

<b>PRECAUTIONS FOR SAFETY .....</b>	<b>6</b>
<b>1. SPECIFICATIONS .....</b>	<b>12</b>
1-1. Compact 4-way cassette type .....	12
1-2. 2-way cassette type .....	14
1-3. 1-way cassette type .....	17
1-4. Floor standing cabinet type .....	18
1-5. Floor standing concealed type .....	19
1-6. Floor standing type .....	20
<b>2. CONSTRUCTION VIEWS (EXTERNAL VIEWS) .....</b>	<b>21</b>
2-1. Compact 4-way cassette type .....	21
2-2. 2-way cassette type .....	22
2-3. 1-way cassette (SH) type .....	25
2-4. Floor standing cabinet type .....	26
2-5. Floor standing concealed type .....	27
2-6. Floor standing type .....	29
<b>3. WIRING DIAGRAMS .....</b>	<b>31</b>
3-1. Compact 4-way cassette type .....	31
3-2. 2-way cassette type .....	32
3-3. 1-way cassette (SH) type .....	33
3-4. Floor standing cabinet type .....	34
3-5. Floor standing concealed type .....	35
3-6. Floor standing type .....	36
<b>4. PARTS RATING .....</b>	<b>37</b>
<b>5. REFRIGERANT CYCLE DIAGRAM .....</b>	<b>38</b>
<b>6. CONTROL OUTLINE .....</b>	<b>39</b>
<b>7. COMMUNICATION TYPE, MODEL NAMES AND THE MAXIMUM NUMBER OF CONNECTABLE UNITS .....</b>	<b>50</b>
<b>8. APPLIED CONTROL AND FUNCTIONS (INCLUDING CIRCUIT CONFIGURATION) .....</b>	<b>51</b>
8-1. Indoor controller block diagram (MCC-1643) .....	51
8-1-1. In case of connection of wired remote controller .....	51
8-1-2. In case of connection of wireless remote controller (Compact 4-way cassette type) .....	53
8-1-3. Connection of both wired remote controller and wireless remote controller ...	54
8-2. Indoor controller block diagram (MCC-1744) .....	55
8-2-1. In case of connection of wired remote controller .....	55
8-2-2. In case of connection of wireless remote controller .....	56
8-2-3. Connection of both wired remote controller and wireless remote controller ...	57
8-3. Indoor Print Circuit Board .....	58
8-3-1. MCC-1643 .....	58
8-3-2. MCC-1744 .....	60
8-4. Test run of indoor unit .....	62
8-5. Method to set indoor unit function DN code .....	66
8-6. Applied control of indoor unit .....	72

<b>9. TROUBLESHOOTING .....</b>	<b>91</b>
9-1. Overview .....	91
9-2. Troubleshooting method .....	92
9-3. Troubleshooting based on information displayed on remote controller .....	98
9-4. Check Codes Displayed on Remote Controller and SMMS series Outdoor Unit (7-Segment Display on I/F Board) and Locations to Be Checked .....	103
9-5. Diagnostic Procedure for Each Check Code (Indoor Unit) .....	118
9-6. Sensor characteristics .....	126
9-7. Maintenance list .....	127
<b>10. P.C. BOARD EXCHANGE PROCEDURES .....</b>	<b>128</b>
10-1. Replacement of indoor P.C. boards .....	128
<b>11. DETACHMENTS .....</b>	<b>135</b>
11-1. Compact 4-way cassette .....	135
11-2. 2-way cassette .....	144
11-3. 1-way cassette (SH) .....	157
11-4. Floor standing cabinet .....	165
11-5. Floor standing concealed .....	170
11-6. Floor standing .....	180
<b>12. EXPLODED VIEWS AND PARTS LIST .....</b>	<b>187</b>
12-1. Compact 4-way cassette type .....	187
12-2. 2-way cassette type .....	191
12-3. 1-way Cassette Type (SH) .....	200
12-4. Floor Standing Cabinet Type .....	204
12-5. Floor Standing Concealed Type .....	207
12-6. Floor Standing Type .....	210

Please read carefully through these instructions that contain important information which complies with the “Machinery” Directive (Directive 2006/42/EC), and ensure that you understand them.

### Definition of Qualified Installer or Qualified Service Person

The air conditioner must be installed, maintained, repaired and removed by a qualified installer or qualified service person. When any of these jobs is to be done, ask a qualified installer or qualified service person to do them.

A qualified installer or qualified service person is an agent who has the qualifications and knowledge described in the table below.

Agent	Qualifications and knowledge which the agent must have
Qualified installer (*1)	<ul style="list-style-type: none"> <li>• The qualified installer is a person who installs, maintains, relocates and removes the air conditioners made by Toshiba Carrier Corporation. He or she has been trained to install, maintain, relocate and remove the air conditioners made by Toshiba Carrier Corporation or, alternatively, he or she has been instructed in such operations by an individual or individuals who have been trained and is thus thoroughly acquainted with the knowledge related to these operations.</li> <li>• The qualified installer who is allowed to do the electrical work involved in installation, relocation and removal has the qualifications pertaining to this electrical work as stipulated by the local laws and regulations, and he or she is a person who has been trained in matters relating to electrical work on the air conditioners made by Toshiba Carrier Corporation or, alternatively, he or she has been instructed in such matters by an individual or individuals who have been trained and is thus thoroughly acquainted with the knowledge related to this work.</li> <li>• The qualified installer who is allowed to do the refrigerant handling and piping work involved in installation, relocation and removal has the qualifications pertaining to this refrigerant handling and piping work as stipulated by the local laws and regulations, and he or she is a person who has been trained in matters relating to refrigerant handling and piping work on the air conditioners made by Toshiba Carrier Corporation or, alternatively, he or she has been instructed in such matters by an individual or individuals who have been trained and is thus thoroughly acquainted with the knowledge related to this work.</li> <li>• The qualified installer who is allowed to work at heights has been trained in matters relating to working at heights with the air conditioners made by Toshiba Carrier Corporation or, alternatively, he or she has been instructed in such matters by an individual or individuals who have been trained and is thus thoroughly acquainted with the knowledge related to this work.</li> </ul>
Qualified service person (*1)	<ul style="list-style-type: none"> <li>• The qualified service person is a person who installs, repairs, maintains, relocates and removes the air conditioners made by Toshiba Carrier Corporation. He or she has been trained to install, repair, maintain, relocate and remove the air conditioners made by Toshiba Carrier Corporation or, alternatively, he or she has been instructed in such operations by an individual or individuals who have been trained and is thus thoroughly acquainted with the knowledge related to these operations.</li> <li>• The qualified service person who is allowed to do the electrical work involved in installation, repair, relocation and removal has the qualifications pertaining to this electrical work as stipulated by the local laws and regulations, and he or she is a person who has been trained in matters relating to electrical work on the air conditioners made by Toshiba Carrier Corporation or, alternatively, he or she has been instructed in such matters by an individual or individuals who have been trained and is thus thoroughly acquainted with the knowledge related to this work.</li> <li>• The qualified service person who is allowed to do the refrigerant handling and piping work involved in installation, repair, relocation and removal has the qualifications pertaining to this refrigerant handling and piping work as stipulated by the local laws and regulations, and he or she is a person who has been trained in matters relating to refrigerant handling and piping work on the air conditioners made by Toshiba Carrier Corporation or, alternatively, he or she has been instructed in such matters by an individual or individuals who have been trained and is thus thoroughly acquainted with the knowledge related to this work.</li> <li>• The qualified service person who is allowed to work at heights has been trained in matters relating to working at heights with the air conditioners made by Toshiba Carrier Corporation or, alternatively, he or she has been instructed in such matters by an individual or individuals who have been trained and is thus thoroughly acquainted with the knowledge related to this work.</li> </ul>



## Definition of Protective Gear

When the air conditioner is to be transported, installed, maintained, repaired or removed, wear protective gloves and 'safety' work clothing.



In addition to such normal protective gear, wear the protective gear described below when undertaking the special work detailed in the table below.

Failure to wear the proper protective gear is dangerous because you will be more susceptible to injury, burns, electric shocks and other injuries.

Work undertaken	Protective gear worn
All types of work	Protective gloves 'Safety' working clothing
Electrical-related work	Gloves to provide protection for electricians Insulating shoes Clothing to provide protection from electric shock
Work done at heights (50 cm or more)	Helmets for use in industry
Transportation of heavy objects	Shoes with additional protective toecap
Repair of outdoor unit	Gloves to provide protection for electricians



The important contents concerned to the safety are described on the product itself and on this Service Manual. Please read this Service Manual after understanding the described items thoroughly in the following contents (Indications / Illustrated marks), and keep them.

### [Explanation of indications]

Indication	Explanation
 <b>DANGER</b>	Indicates contents assumed that an imminent danger causing a death or serious injury of the repair engineers and the third parties when an incorrect work has been executed.
 <b>WARNING</b>	Indicates possibilities assumed that a danger causing a death or serious injury of the repair engineers, the third parties, and the users due to troubles of the product after work when an incorrect work has been executed.
 <b>CAUTION</b>	Indicates contents assumed that an injury or property damage (*) may be caused on the repair engineers, the third parties, and the users due to troubles of the product after work when an incorrect work has been executed.

\* Property damage: Enlarged damage concerned to property, furniture, and domestic animal / pet

### [Explanation of illustrated marks]















Indication	Explanation
	Indicates prohibited items (Forbidden items to do) The sentences near an illustrated mark describe the concrete prohibited contents.
	Indicates mandatory items (Compulsory items to do) The sentences near an illustrated mark describe the concrete mandatory contents.
	Indicates cautions (Including danger / warning) The sentences or illustration near or in an illustrated mark describe the concrete cautious contents.

## Warning Indications on the Air Conditioner Unit

### [Confirmation of warning label on the main unit]

Confirm that labels are indicated on the specified positions





If removing the label during parts replace, stick it as the original.

Warning indication	Description			
<table border="1"> <tr> <td data-bbox="172 434 306 649" rowspan="2">  </td> <td data-bbox="306 434 657 504" style="text-align: center;"><b>WARNING</b></td> </tr> <tr> <td data-bbox="306 504 657 649"> <b>ELECTRICAL SHOCK HAZARD</b>                      Disconnect all remote electric power supplies before servicing.                 </td> </tr> </table>		<b>WARNING</b>	<b>ELECTRICAL SHOCK HAZARD</b> Disconnect all remote electric power supplies before servicing.	<p><b>WARNING</b></p> <p><b>ELECTRICAL SHOCK HAZARD</b>                      Disconnect all remote electric power supplies before servicing.</p>
		<b>WARNING</b>		
	<b>ELECTRICAL SHOCK HAZARD</b> Disconnect all remote electric power supplies before servicing.			
<table border="1"> <tr> <td data-bbox="172 712 306 927" rowspan="2">  </td> <td data-bbox="306 712 657 781" style="text-align: center;"><b>WARNING</b></td> </tr> <tr> <td data-bbox="306 781 657 927">                     Moving parts.                      Do not operate unit with grille removed.                      Stop the unit before the servicing.                 </td> </tr> </table>		<b>WARNING</b>	Moving parts. Do not operate unit with grille removed. Stop the unit before the servicing.	<p><b>WARNING</b></p> <p>Moving parts.                      Do not operate unit with grille removed.                      Stop the unit before the servicing.</p>
		<b>WARNING</b>		
	Moving parts. Do not operate unit with grille removed. Stop the unit before the servicing.			
<table border="1"> <tr> <td data-bbox="172 990 306 1205" rowspan="2">  </td> <td data-bbox="306 990 657 1059" style="text-align: center;"><b>CAUTION</b></td> </tr> <tr> <td data-bbox="306 1059 657 1205">                     High temperature parts.                      You might get burned when removing this panel.                 </td> </tr> </table>		<b>CAUTION</b>	High temperature parts. You might get burned when removing this panel.	<p><b>CAUTION</b></p> <p>High temperature parts.                      You might get burned when removing this panel.</p>
		<b>CAUTION</b>		
	High temperature parts. You might get burned when removing this panel.			
<table border="1"> <tr> <td data-bbox="172 1267 306 1482" rowspan="2">  </td> <td data-bbox="306 1267 657 1337" style="text-align: center;"><b>CAUTION</b></td> </tr> <tr> <td data-bbox="306 1337 657 1482">                     Do not touch the aluminum fins of the unit.                      Doing so may result in injury.                 </td> </tr> </table>		<b>CAUTION</b>	Do not touch the aluminum fins of the unit. Doing so may result in injury.	<p><b>CAUTION</b></p> <p>Do not touch the aluminium fins of the unit.                      Doing so may result in injury.</p>
		<b>CAUTION</b>		
	Do not touch the aluminum fins of the unit. Doing so may result in injury.			
<table border="1"> <tr> <td data-bbox="172 1545 306 1760" rowspan="2">  </td> <td data-bbox="306 1545 657 1615" style="text-align: center;"><b>CAUTION</b></td> </tr> <tr> <td data-bbox="306 1615 657 1760"> <b>BURST HAZARD</b>                      Open the service valves before the operation, otherwise there might be the burst.                 </td> </tr> </table>		<b>CAUTION</b>	<b>BURST HAZARD</b> Open the service valves before the operation, otherwise there might be the burst.	<p><b>CAUTION</b></p> <p><b>BURST HAZARD</b>                      Open the service valves before the operation, otherwise there might be the burst.</p>
		<b>CAUTION</b>		
	<b>BURST HAZARD</b> Open the service valves before the operation, otherwise there might be the burst.			

# PRECAUTIONS FOR SAFETY



The manufacturer shall not assume any liability for the damage caused by not observing the description of this manual.

## DANGER







 Turn off breaker	<p>Before carrying out the installation, maintenance, repair or removal work, be sure to set the circuit breaker for both the indoor and outdoor units to the OFF position. Otherwise, electric shocks may result.</p>
	<p>Before opening the intake grille of the indoor unit or service panel of the outdoor unit, set the circuit breaker to the OFF position. Failure to set the circuit breaker to the OFF position may result in electric shocks through contact with the interior parts. Only a qualified installer (*1) or qualified service person (*1) is allowed to remove the intake grille of the indoor unit or service panel of the outdoor unit and do the work required.</p>
	<p>Before opening the electric box cover set the circuit breaker to the OFF position. Failure to set the circuit breaker to the OFF position may result in injury through contact with the rotation parts. Only a qualified installer (*1) or qualified service person (*1) is allowed to remove the electric box cover and do the work required.</p>
	<p>Before starting to repair the outdoor unit fan or fan guard, be absolutely sure to set the circuit breaker to the OFF position, and place a "Work in progress" sign on the circuit breaker.</p>
	<p>When cleaning the filter or other parts of the indoor unit, set the circuit breaker to OFF without fail, and place a "Work in progress" sign near the circuit breaker before proceeding with the work.</p>
	<p>When you have noticed that some kind of trouble (such as when a check code display has appeared, there is a smell of burning, abnormal sounds are heard, the air conditioner fails to cool or heat or water is leaking) has occurred in the air conditioner, do not touch the air conditioner yourself but set the circuit breaker to the OFF position, and contact a qualified service person. Take steps to ensure that the power will not be turned on (by marking "out of service" near the circuit breaker, for instance) until qualified service person arrives. Continuing to use the air conditioner in the trouble status may cause mechanical problems to escalate or result in electric shocks or other failure.</p>
 Electric shock hazard	<p>When you access inside of the electric cover to repair electric parts, wait for about five minutes after turning off the breaker. Do not start repairing immediately. Otherwise you may get electric shock by touching terminals of high-voltage capacitors. Natural discharge of the capacitor takes about five minutes.</p>
	<p>When checking the electric parts, removing the cover of the electric parts box of Indoor Unit and/or service panel of Outdoor Unit inevitably to determine the failure, use gloves to provide protection for electricians, insulating shoes, clothing to provide protection from electric shock and insulating tools. Be careful not to touch the live part. Electric shock may result. Only "Qualified service person" is allowed to do this work.</p>
 Prohibition	<p>Place a "Work in progress" sign near the circuit breaker while the installation, maintenance, repair or removal work is being carried out. There is a danger of electric shocks if the circuit breaker is set to ON by mistake.</p>
	<p>When checking the electric parts, removing the cover of the electric parts box of Indoor Unit and/or front panel of outdoor unit inevitably to determine the failure, put a sign "Do not enter" around the site before the work. Failure to do this may result in third person getting electric shock.</p>
	<p>Before operating the air conditioner after having completed the work, check that the electrical parts box cover of the indoor unit and service panel of the outdoor unit are closed, and set the circuit breaker to the ON position. You may receive an electric shock if the power is turned on without first conducting these checks.</p>
 Stay on protection	<p>If, in the course of carrying out repairs, it becomes absolutely necessary to check out the electrical parts with the electrical parts box cover of one or more of the indoor units and the service panel of the outdoor unit removed in order to find out exactly where the trouble lies, wear insulated heat-resistant gloves, insulated boots and insulated work overalls, and take care to avoid touching any live parts. You may receive an electric shock if you fail to heed this warning. Only qualified service person (*1) is allowed to do this kind of work.</p>







(\*1) Refer to the "Definition of Qualified Installer or Qualified Service Person"

 **WARNIG**

 General	<p>Before starting to repair the air conditioner, read carefully through the Service Manual, and repair the air conditioner by following its instructions.</p>
	<p>Only qualified service person (*1) is allowed to repair the air conditioner. Repair of the air conditioner by unqualified person may give rise to a fire, electric shocks, injury, water leaks and / or other problems.</p>
	<p>Do not use any refrigerant different from the one specified for complement or replacement. Otherwise, abnormally high pressure may be generated in the refrigeration cycle, which may result in a failure or explosion of the product or an injury to your body.</p>
	<p>Only a qualified installer (*1) or qualified service person (*1) is allowed to carry out the electrical work of the air conditioner. Under no circumstances must this work be done by an unqualified individual since failure to carry out the work properly may result in electric shocks and / or electrical leaks.</p>
	<p>When the air conditioner is to be transported, installed, maintained, repaired or removed, wear protective gloves and 'safety' work clothing.</p>
	<p>To connect the electrical wires, repair the electrical parts or undertake other electrical jobs, wear gloves to provide protection for electricians, insulating shoes and clothing to provide protection from electric shocks. Failure to wear this protective gear may result in electric shocks.</p>
	<p>Electrical wiring work shall be conducted according to law and regulation in the community and Installation Manual. Failure to do so may result in electrocution or short circuit.</p>
	<p>Use wiring that meets the specifications in the Installation Manual and the stipulations in the local regulations and laws. Use of wiring which does not meet the specifications may give rise to electric shocks, electrical leakage, smoking and/or a fire.</p>
	<p>Only a qualified installer (*1) or qualified service person (*1) is allowed to undertake work at heights using a stand of 50 cm or more or to remove the intake grille of the indoor unit to undertake work.</p>
	<p>When working at heights, use a ladder which complies with the ISO 14122 standard, and follow the procedure in the ladder's instructions. Also wear a helmet for use in industry as protective gear to undertake the work.</p>
	<p>Before working at heights, put a sign in place so that no-one will approach the work location, before proceeding with the work. Parts and other objects may fall from above, possibly injuring a person below. While carrying out the work, wear a helmet for protection from falling objects.</p>
	<p>When executing address setting, test run, or troubleshooting through the checking window on the electric parts box, put on insulated gloves to provide protection from electric shock. Otherwise you may receive an electric shock.</p>
	<p>Do not touch the aluminum fin of the unit. You may injure yourself if you do so. If the fin must be touched for some reason, first put on protective gloves and safety work clothing, and then proceed.</p>
	<p>Do not climb onto or place objects on top of the outdoor unit. You may fall or the objects may fall off the outdoor unit and result in injury.</p>
	<p>Use forklift truck to carry in the air conditioner units and use winch or hoist at installation of them.</p>
	<p>When transporting the air conditioner, wear shoes with protective toe caps, protective gloves and other protective clothing.</p>
	<p>When transporting the air conditioner, do not hold the bands around the packing carton. You may injure yourself if the bands should break.</p>
<p>Be sure that a heavy unit (10 kg or heavier) such as a compressor is carried by four persons.</p>	
 Check earth wires.	<p>Before troubleshooting or repair work, check the earth wire is connected to the earth terminals of the main unit, otherwise an electric shock is caused when a leak occurs. If the earth wire is not correctly connected, contact an electric engineer for rework.</p>
	<p>After completing the repair or relocation work, check that the ground wires are connected properly.</p>
	<p>Connect earth wire. (Grounding work) Incomplete grounding causes an electric shock. Do not connect earth wires to gas pipes, water pipes, and lightning rods or ground wires for telephone wires.</p>



(\*1) Refer to the "Definition of Qualified Installer or Qualified Service Person"

 Prohibition of modification.	Do not modify the products. Do not also disassemble or modify the parts. It may cause a fire, electric shock or injury.
 Use specified parts.	When any of the electrical parts are to be replaced, ensure that the replacement parts satisfy the specifications given in the Service Manual (or use the parts contained on the parts list in the Service Manual). Use of any parts which do not satisfy the required specifications may give rise to electric shocks, smoking and / or a fire.
 Do not bring a child close to the equipment.	If, in the course of carrying out repairs, it becomes absolutely necessary to check out the electrical parts with the electrical parts box cover of one or more of the indoor units and the service panel of the outdoor unit removed in order to find out exactly where the trouble lies, put a sign in place so that no one will approach the work location before proceeding with the work. Third-party individuals may enter the work site and receive electric shocks if this warning is not heeded.
 Insulating measures	Connect the cut-off lead wires with crimp contact, etc., put the closed end side upward and then apply a watercut method, otherwise a leak or production of fire is caused at the users' side.
 No fire	When performing repairs using a gas burner, replace the refrigerant with nitrogen gas because the oil that coats the pipes may otherwise burn. When repairing the refrigerating cycle, take the following measures. 1) Be attentive to fire around the cycle. When using a gas stove, etc., be sure to put out fire before work; otherwise the oil mixed with refrigerant gas may catch fire. 2) Do not use a welder in the closed room. When using it without ventilation, carbon monoxide poisoning may be caused. 3) Do not bring inflammables close to the refrigerant cycle, otherwise fire of the welder may catch the inflammables.
 Refrigerant	The refrigerant used by this air conditioner is the R410A. Check the used refrigerant name and use tools and materials of the parts which match with it. For the products which use R410A refrigerant, the refrigerant name is indicated at a position on the outdoor unit where is easy to see. To prevent miss charging, the route of the service port is changed from one of the former R22. Do not use any refrigerant different from the one specified for complement or replacement. Otherwise, abnormally high pressure may be generated in the refrigeration cycle, which may result in a failure or explosion of the product or an injury to your body. For an air conditioner which uses R410A, never use other refrigerant than R410A. For an air conditioner which uses other refrigerant (R22, etc.), never use R410A. If different types of refrigerant are mixed, abnormal high pressure generates in the refrigerating cycle and an injury due to breakage may be caused. When the air conditioner has been installed or relocated, follow the instructions in the Installation Manual and purge the air completely so that no gases other than the refrigerant will be mixed in the refrigerating cycle. Failure to purge the air completely may cause the air conditioner to malfunction. Do not charge refrigerant additionally. If charging refrigerant additionally when refrigerant gas leaks, the refrigerant composition in the refrigerating cycle changes resulted in change of air conditioner characteristics or refrigerant over the specified standard amount is charged and an abnormal high pressure is applied to the inside of the refrigerating cycle resulted in cause of breakage or injury. Therefore if the refrigerant gas leaks, recover the refrigerant in the air conditioner, execute vacuuming, and then newly recharge the specified amount of liquid refrigerant. In this time, never charge the refrigerant over the specified amount. When recharging the refrigerant in the refrigerating cycle, do not mix the refrigerant or air other than R410A into the specified refrigerant. If air or others is mixed with the refrigerant, abnormal high pressure generates in the refrigerating cycle resulted in cause of injury due to breakage. After installation work, check the refrigerant gas does not leak. If the refrigerant gas leaks in the room, poisonous gas generates when gas touches to fire such as fan heater, stove or cooking stove though the refrigerant gas itself is innocuous. Never recover the refrigerant into the outdoor unit. When the equipment is moved or repaired, be sure to recover the refrigerant with recovering device. The refrigerant cannot be recovered in the outdoor unit; otherwise a serious accident such as breakage or injury is caused.

 Assembly / Wiring	After repair work, surely assemble the disassembled parts, and connect and lead the removed wires as before. Perform the work so that the cabinet or panel does not catch the inner wires. If incorrect assembly or incorrect wire connection was done, a disaster such as a leak or fire is caused at user's side.
 Insulator check	After the work has finished, be sure to use an insulation tester set (500VMΩ) to check the resistance is 1 MΩ or more between the charge section and the non-charge metal section (Earth position). If the resistance value is low, a disaster such as a leak or electric shock is caused at user's side.
 Ventilation	When the refrigerant gas leaks during work, execute ventilation. If the refrigerant gas touches to a fire, poisonous gas generates. A case of leakage of the refrigerant and the closed room full with gas is dangerous because a shortage of oxygen occurs. Be sure to execute ventilation. If refrigerant gas has leaked during the installation work, ventilate the room immediately. If the leaked refrigerant gas comes in contact with fire, noxious gas may generate. After installation work, check the refrigerant gas does not leak. If the refrigerant gas leaks in the room, poisonous gas generates when gas touches to fire such as fan heater, stove or cooking stove though the refrigerant gas itself is innocuous.
 Compulsion	When the refrigerant gas leaks, find out the leaked position and repair it surely. If the leaked position cannot be found out and the repair work is interrupted, reclaim and tighten the service valve, otherwise the refrigerant gas may leak into the room. The poisonous gas generates when gas touches to fire such as fan heater, stove or cooking stove though the refrigerant gas itself is innocuous. When installing equipment which includes a large amount of charged refrigerant in a sub-room, it is necessary that the concentration does not the limit even if the refrigerant leaks. If the refrigerant leaks and exceeds the limit concentration, an accident of shortage of oxygen is caused. Tighten the flare nut with a torque wrench in the specified manner. Excessive tighten of the flare nut may cause a crack in the flare nut after a long period, which may result in refrigerant leakage. Nitrogen gas must be used for the airtight test. The charge hose must be connected in such a way that it is not slack. For the installation / moving / reinstallation work, follow to the Installation Manual. If an incorrect installation is done, a trouble of the refrigerating cycle, water leak, electric shock or fire is caused.
 Check after repair	Once the repair work has been completed, check for refrigerant leaks, and check the insulation resistance and water drainage. Then perform a trial run to check that the air conditioner is running properly. After repair work has finished, check there is no trouble. If check is not executed, a fire, electric shock or injury may be caused. For a check, turn off the power breaker. After repair work (installation of front panel and cabinet) has finished, execute a test run to check there is no generation of smoke or abnormal sound. If check is not executed, a fire or an electric shock is caused. Before test run, install the front panel and cabinet. Be sure to fix the screws back which have been removed for installation or other purposes.
 Do not operate the unit with the valve closed.	Check the following matters before a test run after repairing piping. <ul style="list-style-type: none"> <li>• Connect the pipes surely and there is no leak of refrigerant.</li> <li>• The valve is opened.</li> </ul> Running the compressor under condition that the valve closes causes an abnormal high pressure resulted in damage of the parts of the compressor and etc. and moreover if there is leak of refrigerant at connecting section of pipes, the air is sucked and causes further abnormal high pressure resulted in burst or injury.
 Check after reinstallation	Only a qualified installer (*1) or qualified service person (*1) is allowed to relocate the air conditioner. It is dangerous for the air conditioner to be relocated by an unqualified individual since a fire, electric shocks, injury, water leakage, noise and / or vibration may result. Check the following items after reinstallation. <ol style="list-style-type: none"> <li>1) The earth wire is correctly connected.</li> <li>2) The power cord is not caught in the product.</li> <li>3) There is no inclination or unsteadiness and the installation is stable.</li> </ol> If check is not executed, a fire, an electric shock or an injury is caused. When carrying out the reclaim work shut down the compressor before disconnecting the refrigerant pipe. Disconnecting the refrigerant pipe with the service valve left open and the compressor still operating will cause air, etc. to be sucked in, raising the pressure inside the refrigeration cycle to an abnormally high level, and possibly resulting in rupture, injury, etc.

(\*1) Refer to the "Definition of Qualified Installer or Qualified Service Person"



 Cooling check	<p>When the service panel of the outdoor unit is to be opened in order for the compressor or the area around this part to be repaired immediately after the air conditioner has been shut down, set the circuit breaker to the OFF position, and then wait at least 10 minutes before opening the service panel. If you fail to heed this warning, you will run the risk of burning yourself because the compressor pipes and other parts will be very hot to the touch. In addition, before proceeding with the repair work, wear the kind of insulated heat-resistant gloves designed to protect electricians.</p>
	<p>Take care not to get burned by compressor pipes or other parts when checking the cooling cycle while running the unit as they get heated while running. Be sure to put on gloves providing protection for heat.</p>
 Installation	<p>When the service panel of the outdoor unit is to be opened in order for the fan motor, reactor, inverter or the areas around these parts to be repaired immediately after the air conditioner has been shut down, set the circuit breaker to the OFF position, and then wait at least 10 minutes before opening the service panel. If you fail to heed this warning, you will run the risk of burning yourself because the fan motor, reactor, inverter heat sink and other parts will be very hot to the touch. In addition, before proceeding with the repair work, wear the kind of insulated heat-resistant gloves designed to protect electricians.</p>
	<p>Only a qualified installer or service person is allowed to do installation work. Inappropriate installation may result in water leakage, electric shock or fire.</p>
	<p>Before starting to install the air conditioner, read carefully through the Installation Manual, and follow its instructions to install the air conditioner.</p>
	<p>Be sure to use the company-specified products for the separately purchased parts. Use of non-specified products may result in fire, electric shock, water leakage or other failure. Have the installation performed by a qualified installer.</p>
	<p>Do not supply power from the power terminal block equipped on the outdoor unit to another outdoor unit. Capacity overflow may occur on the terminal block and may result in fire.</p>
	<p>Do not install the air conditioner in a location that may be subject to a risk of exposure to a combustible gas. If a combustible gas leaks and becomes concentrated around the unit, a fire may occur.</p>
	<p>Install the indoor unit at least 2.5 m above the floor level since otherwise the users may injure themselves or receive electric shocks if they poke their fingers or other objects into the indoor unit while the air conditioner is running.</p>
	<p>Install a circuit breaker that meets the specifications in the Installation Manual and the stipulations in the local regulations and laws.</p>
	<p>Install the circuit breaker where it can be easily accessed by the agent.</p>
	<p>If you install the unit in a small room, take appropriate measures to prevent the refrigerant from exceeding the limit concentration even if it leaks. Consult the dealer from whom you purchased the air conditioner when you implement the measures. Accumulation of highly concentrated refrigerant may cause an oxygen deficiency accident.</p>
<p>Do not place any combustion appliance in a place where it is directly exposed to the wind of air conditioner, otherwise it may cause imperfect combustion.</p>	

### Explanations given to user

If you have discovered that the fan grille is damaged, do not approach the outdoor unit but set the circuit breaker to the OFF position, and contact a qualified service person to have the repairs done. Do not set the circuit breaker to the ON position until the repairs are completed.

### Relocation

- Only a qualified installer (\*1) or qualified service person (\*1) is allowed to relocate the air conditioner. It is dangerous for the air conditioner to be relocated by an unqualified individual since a fire, electric shocks, injury, water leakage, noise and / or vibration may result.
- When carrying out the reclaim work shut down the compressor before disconnecting the refrigerant pipe. Disconnecting the refrigerant pipe with the service valve left open and the compressor still operating will cause air, etc. to be sucked in, raising the pressure inside the refrigeration cycle to an abnormally high level, and possibly resulting in rupture, injury, etc.

(\*1) Refer to the “Definition of Qualified Installer or Qualified Service Person”

# 1. SPECIFICATIONS

## 1-1. Compact 4-way cassette type



Model name			MMU-UP0051MH-E(TR)	MMU-UP0071MH-E(TR)	MMU-UP0091MH-E(TR)	MMU-UP0121MH-E(TR)
Cooling Capacity	(*1)	kW	1.7	2.2	2.8	3.6
Heating Capacity	(*1)	kW	1.9	2.5	3.2	4.0
Electrical characteristics	Power supply	220-240 ~, 50Hz / 208-230 ~, 60Hz				
	Running current	A	0.16 / 0.15	0.23 / 0.21	0.24 / 0.22	0.25 / 0.23
	Power consumption	kW	0.016 / 0.016	0.023 / 0.023	0.025 / 0.025	0.027 / 0.027
	Starting current	A	0.28 / 0.27	0.41 / 0.38	0.43 / 0.39	0.44 / 0.41
Appearance	Main Unit	Zinc hot dipping steel plate * Heat-insulating material attached to only upper plate				
	Ceiling Panel (*2)	Model Name	RBC-UM21PG(W)-E			
		Panel Color	Gran White (Munsell 5PB9/1)			
Outer dimension	Main Unit	Height (*3)	mm	256		
		Width	mm	575		
		Depth (*4)	mm	575		
	Ceiling Panel	Height (*3)	mm	12		
		Width	mm	620		
		Depth	mm	620		
Total weight	Main Unit	kg	15			
	Ceiling Panel	kg	2.5			
Heat exchanger	Finned tube					
Soundproof/Heat-insulating material	Non-flammable insulation					
Fan unit	Fan	Turbo fan				
	Standard air flow (M+ / M / L+ / L)	m <sup>3</sup> /h	430(415/400/385/365)	552(500/462/395/378)	570(520/468/395/378)	594(550/504/420/402)
	Motor	W	60			
Air filter	Standard filter (Long life filter)					
Controller	Remote controller					
Connecting pipe	Gas side	mm	Dia. 9.5			
	Liquid side	mm	Dia. 6.4			
Drain port (Nominal dia. mm)	VP20 (Polyvinyl chloride tube)					
Sound pressure level	High (M+ / M / L+ / L)	dB	32 ( 31 / 30 / 29 / 29 )	37 ( 34 / 33 / 30 / 29 )	38 ( 35 / 33 / 30 / 29 )	38 ( 36 / 34 / 31 / 30 )
Sound power level	High (M+ / M / L+ / L)	dB	47 ( 46 / 45 / 44 / 44 )	52 ( 49 / 48 / 45 / 44 )	53 ( 50 / 48 / 45 / 44 )	53 ( 51 / 49 / 46 / 45 )

### Note

- (\*1) Cooling / heating capacity is based on single connection operation with standard piping length under Japanese Industrial Standard B 8615 Condition 1.
- (\*2) Remote controller and ceiling panel are sold separately
- (\*3) Height from the ceiling.
- (\*4) Depth doesn't including the Electric parts box.



Model name			MMU-UP0151MH-E(TR)	MMU-UP0181MH-E(TR)
Cooling Capacity	(*1)	kW	4.5	5.6
Heating Capacity	(*1)	kW	5.0	6.3
Electrical characteristics	Power supply		220-240 ~, 50Hz / 208-230 ~, 60Hz	
	Running current	A	0.28 / 0.26	0.46 / 0.46
	Power consumption	kW	0.030 / 0.030	0.052 / 0.052
	Starting current	A	0.50 / 0.47	0.80 / 0.81
Appearance	Main Unit		Zinc hot dipping steel plate * Heat-insulating material attached to only upper plate	
	Ceiling Panel (*2)	Model Name	RBC-UM21PG(W)-E	
		Panel Color	Gran White (Munsell 5PB9/1)	
Outer dimension	Main Unit	Height (*3)	mm	256
		Width	mm	575
		Depth (*4)	mm	575
	Ceiling Panel	Height (*3)	mm	12
		Width	mm	620
		Depth	mm	620
Total weight	Main Unit		kg	15
	Ceiling Panel		kg	2.5
Heat exchanger			Finned tube	
Soundproof/Heat-insulating material			Non-flammable insulation	
Fan unit	Fan		Turbo fan	
	Standard air flow ( M+ / M / L+ / L )		m <sup>3</sup> /h	660(600/552/480/468)      840(740/642/540/522)
	Motor		W	60
Air filter			Standard filter (Long life filter)	
Controller (*2)			Remote controller	
Connecting pipe	Gas side		mm	Dia. 12.7
	Liquid side		mm	Dia. 6.4
Drain port (Nominal dia. mm)			VP20 (Polyvinyl chloride tube)	
Sound pressure level	High ( M+ / M / L+ / L )		dB	40 ( 37 / 35 / 32 / 31 )      47 ( 43 / 39 / 36 / 34 )
Sound power level	High ( M+ / M / L+ / L )		dB	55 ( 52 / 50 / 47 / 46 )      62 ( 58 / 54 / 51 / 49 )

**Note**

- (\*1) Cooling / heating capacity is based on single connection operation with standard piping length under Japanese Industrial Standard B 8615 Condition 1.
- (\*2) Remote controller and ceiling panel are sold separately
- (\*3) Height from the ceiling.
- (\*4) Depth doesn't including the Electric parts box.

## 1-2. 2-way cassette type



Model name		MMU-	UP0071WH-E(TR)	UP0091WH-E(TR)	UP0121WH-E(TR)	UP0151WH-E(TR)
Cooling / Heating capacity (*1)		kW	2.2 / 2.5	2.8 / 3.2	3.6 / 4.0	4.5 / 5.0
Electrical characteristics	Power supply		220-240V ~, 50Hz / 208-230V ~, 60Hz			
	Running current	A	0.21 / 0.22			0.22 / 0.23
	Power consumption	kW	0.024 / 0.024			0.026 / 0.026
	Starting current	A	0.31 / 0.32			0.33 / 0.35
Appearance	Main Unit		Heat-insulating material attached Zinc hot dipping steel plate			
	Ceiling Panel	Model Name		RBC-UW283PG(W)-E		
		Panel Color		Moon White (Munsell 2.5GY9.0/0.5)		
Outer dimension	Main Unit	Height	mm	295		
		Width	mm	815		
		Depth	mm	570		
	Ceiling Panel	Height	mm	20		
		Width	mm	1050		
		Depth	mm	680		
Total weight	Main Unit		kg	18		
	Ceiling Panel		kg	10		
Heat exchanger			Finned tube			
Soundproof / Heat-insulating material			Non-flammable insulation			
Fan unit	Fan		Turbo fan			
	Standard air flow ( H / M+ / M / L+ / L )		m <sup>3</sup> /h	558 / 516 / 498 / 468 / 450		600 / 552 / 534 / 480 / 450
	Motor		W	60		
Air filter			Standard filter (Long life filter)			
Controller			Remote controller			
Connecting pipe	Gas side	mm	Dia. 9.5		Dia. 12.7	
	Liquid side	mm	Dia. 6.4			
Drain port (Nominal dia. mm)			25 (Polyvinyl chloride tube)			
Sound pressure level ( H / M+ / M / L+ / L )		dB(A)	34 / 33 / 32 / 31 / 30		35 / 34 / 33 / 31 / 30	

### Note

(\*1) Rated conditions    Cooling : Indoor 27 °C Dry Bulb / 19 °C Wet Bulb, Outdoor 35 °C Dry Bulb.  
 Heating : Indoor 20 °C Dry Bulb, Outdoor 7 °C Dry Bulb / 6 °C Wet Bulb.  
 Based on equivalent piping length of 7.5 m and piping height difference of 0 m.

Model name		MMU-	UP0181WH-E(TR)	UP0241WH-E(TR)	UP0271WH-E(TR)	UP0301WH-E(TR)	
Cooling / Heating capacity (*1)		kW	5.6 / 6.3	7.1 / 8.0	8.0 / 9.0	9.0 / 10.0	
Electrical characteristics	Power supply		220-240V ~, 50Hz / 208-230V ~, 60Hz				
	Running current	A	0.28 / 0.29	0.37 / 0.39		0.43 / 0.46	
	Power consumption	kW	0.034 / 0.034	0.045 / 0.045		0.055 / 0.055	
	Starting current	A	0.42 / 0.44	0.57 / 0.60		0.65 / 0.68	
Appearance	Main Unit		Heat-insulating material attached Zinc hot dipping steel plate				
	Ceiling Panel	Model Name		RBC-UW803PG(W)-E			
		Panel Color		Moon White (Munsell 2.5GY9.0/0.5)			
Outer dimension	Main Unit	Height	mm	345			
		Width	mm	1180			
		Depth	mm	570			
	Ceiling Panel	Height	mm	20			
		Width	mm	1415			
		Depth	mm	680			
Total weight	Main Unit		kg	26			
	Ceiling Panel		kg	14			
Heat exchanger			Finned tube				
Soundproof / Heat-insulating material			Non-flammable insulation				
Fan unit	Fan		Centrifugal fan				
	Standard air flow ( H / M+ / M / L+ / L )		m <sup>3</sup> /h	900 / 810 / 750 / 678 / 618	1050 / 942 / 840 / 780 / 738		1260 / 1062 / 900 / 840 / 780
	Motor		W	94			
Air filter			Standard filter (Long life filter)				
Controller			Remote controller				
Connecting pipe	Gas side		mm	Dia. 12.7	Dia. 15.9		
	Liquid side		mm	Dia. 6.4	Dia. 9.5		
Drain port (Nominal dia. mm)			25 (Polyvinyl chloride tube)				
Sound pressure level ( H / M+ / M / L+ / L )		dB(A)	35 / 34 / 33 / 31 / 30	38 / 37 / 35 / 34 / 33		40 / 38 / 37 / 35 / 34	

**Note**

(\*1) Rated conditions    Cooling : Indoor 27 °C Dry Bulb / 19 °C Wet Bulb, Outdoor 35 °C Dry Bulb.  
Heating : Indoor 20 °C Dry Bulb, Outdoor 7 °C Dry Bulb / 6 °C Wet Bulb.  
Based on equivalent piping length of 7.5 m and piping height difference of 0 m.

Model name		MMU-	UP0361WH-E(TR)	UP0481WH-E(TR)	UP0561WH-E(TR)	
Cooling / Heating capacity (*1)		kW	11.2 / 12.5	14.0 / 16.0	16.0 / 18.0	
Electrical characteristics	Power supply		220-240V ~, 50Hz / 208-230V ~, 60Hz			
	Running current	A	0.50 / 0.53	0.57 / 0.59	0.77 / 0.81	
	Power consumption	kW	0.081 / 0.081	0.091 / 0.091	0.131 / 0.131	
	Starting current	A	0.76 / 0.79	0.85 / 0.89	1.17 / 1.22	
Appearance	Main Unit		Heat-insulating material attached Zinc hot dipping steel plate			
	Ceiling Panel	Model Name	RBC-UW1403PG(W)-E			
		Panel Color	Moon White (Munsell 2.5GY9.0/0.5)			
Outer dimension	Main Unit	Height	mm	345		
		Width	mm	1600		
		Depth	mm	570		
	Ceiling Panel	Height	mm	20		
		Width	mm	1835		
		Depth	mm	680		
Total weight	Main Unit		kg	35		
	Ceiling Panel		kg	14		
Heat exchanger			Finned tube			
Soundproof / Heat-insulating material			Non-flammable insulation			
Fan unit	Fan		Centrifugal fan			
	Standard air flow ( H / M+ / M / L+ / L )		m <sup>3</sup> /h	1740 / 1530 / 1434 1260 / 1182	1800 / 1608 / 1482 1320 / 1230	2040 / 1770 / 1578 1410 / 1320
	Motor		W	139		
Air filter			Standard filter (Long life filter)			
Controller			Remote controller			
Connecting pipe	Gas side	mm	Dia. 15.9			
	Liquid side	mm	Dia. 9.5			
Drain port (Nominal dia. mm)			25 (Polyvinyl chloride tube)			
Sound pressure level ( H / M+ / M / L+ / L )		dB(A)	42 / 41 / 39 / 37 / 36	43 / 42 / 40 / 38 / 37	46 / 44 / 42 / 40 / 39	

**Note**

(\*1) Rated conditions    Cooling : Indoor 27 °C Dry Bulb / 19 °C Wet Bulb, Outdoor 35 °C Dry Bulb.  
Heating : Indoor 20 °C Dry Bulb, Outdoor 7 °C Dry Bulb / 6 °C Wet Bulb.  
Based on equivalent piping length of 7.5 m and piping height difference of 0 m.

### 1-3. 1-way cassette type



Model name		<b>MMU-</b>	<b>UP0151SH-E(TR)</b>	<b>UP0181SH-E(TR)</b>	<b>UP0241SH-E(TR)</b>
Cooling / Heating capacity (*1)		kW	4.5 / 5.0	5.6 / 6.3	7.1 / 8.0
Electrical characteristics	Power supply		220-240V ~ 50Hz / 208-230V ~ 60Hz		
	Running current	A	0.34 / 0.36	0.36 / 0.37	0.54 / 0.57
	Power consumption	kW	0.039 / 0.039	0.042 / 0.042	0.064 / 0.064
	Starting current	A	0.44 / 0.46	0.47 / 0.49	0.70 / 0.73
Appearance	Main Unit		Heat-insulating material attached Zinc hot dipping steel plate		
	Ceiling Panel	Model Name		RBC-US21PGE	
		Panel Color		Moon White (Munsell 2.5GY9.0/0.5)	
Outer dimension	Main Unit	Height	mm	200	
		Width	mm	1000	
		Depth	mm	710	
	Ceiling Panel	Height	mm	20	
		Width	mm	1230	
		Depth	mm	800	
Total weight	Main Unit		kg	20	21
	Ceiling Panel		kg	5.5	
Heat exchanger			Finned tube		
Soundproof / Heat-insulating material			Polyethylene foam + Expanded polyethylene		
Fan unit	Fan		Centrifugal fan		
	Standard air flow ( H / M+ / M / L+ / L )	m <sup>3</sup> /h	750 / 720 / 690 / 650 / 630	780 / 750 / 720 / 680 / 660	1140 / 1050 / 960 / 840 / 810
	Motor		W	94	
Air filter			Standard filter (Long life filter)		
Controller			Remote controller		
Connecting pipe	Gas side	mm	Dia. 12.7		Dia. 15.9
	Liquid side	mm	Dia. 6.4		Dia. 9.5
Drain port (Nominal dia. mm)			25 (Polyvinyl chloride tube)		
Sound pressure level ( H / M+ / M / L+ / L )		dB(A)	37 / 36 / 35 / 34 / 32	38 / 37 / 36 / 35 / 34	45 / 43 / 41 / 39 / 37

**Note**

(\*1) Rated conditions    Cooling : Indoor 27 °C Dry Bulb / 19 °C Wet Bulb, Outdoor 35 °C Dry Bulb.  
 Heating : Indoor 20 °C Dry Bulb, Outdoor 7 °C Dry Bulb / 6 °C Wet Bulb.  
 Based on equivalent piping length of 7.5 m and piping height difference of 0 m.

# 1-4. Floor standing cabinet type



Model name		MML-	UP0071H-E(TR)	UP0091H-E(TR)	UP0121H-E(TR)	UP0151H-E(TR)	UP0181H-E(TR)	UP0241H-E(TR)	
Cooling/Heating capacity (*1)		kW	2.2 / 2.5	2.8 / 3.2	3.6 / 4.0	4.5 / 5.0	5.6 / 6.3	7.1 / 8.0	
Electrical characteristics	Power supply		220-240V ~, 50Hz / 220V ~, 60Hz						
	Running current	A	0.26 / 0.25		0.43 / 0.44		0.47 / 0.53		
	Power consumption	kW	0.056 / 0.053		0.092 / 0.092		0.102 / 0.113		
	Starting current	A	0.60 / 0.60		0.80 / 0.80		1.10 / 1.10		
Appearance			Munsell1Y8.5/0.5						
Outer dimension	Height	mm	630						
	Width	mm	950						
	Depth	mm	230						
Total weight		kg	35				38		
Heat exchanger			Finned tube						
Soundproof/Heat-insulating material			Non-flammable insulation						
Fan unit	Fan		Centrifugal fan						
	Standard air flow (High/Mid./Low)	m <sup>3</sup> /h	480 / 420 / 360		900 / 780 / 650		1,080 / 930 / 780		
	Motor output	W	45				70		
Air filter			Standard filter (Simple filter)						
Controller			Remote controller (Sold separately)						
Connecting pipe	Gas side	mm	Dia. 9.5			Dia. 12.7		Dia. 15.9	
	Liquid side	mm	Dia. 6.4						
	Drain port (Nominal dia.)	mm	20 (Polyvinyl chloride tube)						
Sound pressure level (High/Mid./Low)		dB(A)	39 / 37 / 35		45 / 41 / 38		49 / 44 / 39		

**Note**

(\*1) Rated conditions    Cooling : Indoor 27 °C Dry Bulb / 19 °C Wet Bulb, Outdoor 35 °C Dry Bulb.  
 Heating : Indoor 20 °C Dry Bulb, Outdoor 7 °C Dry Bulb / 6 °C Wet Bulb.  
 Based on equivalent piping length of 7.5 m and piping height difference of 0 m.

## 1-5. Floor standing concealed type

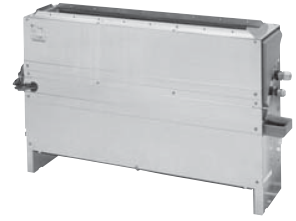

Model name		MML-	UP0071BH-E(TR)	UP0091BH-E(TR)	UP0121BH-E(TR)	UP0151BH-E(TR)	UP0181BH-E(TR)	UP0241BH-E(TR)
Cooling/Heating capacity (*1)		kW	2.2 / 2.5	2.8 / 3.2	3.6 / 4.0	4.5 / 5.0	5.6 / 6.3	7.1 / 8.0
Electrical characteristics	Power supply		220-240V ~, 50Hz / 220V ~, 60Hz					
	Running current	A	0.25 / 0.27			0.45 / 0.46		0.46 / 0.51
	Power consumption	kW	0.056 / 0.058			0.090 / 0.096		0.095 / 0.110
	Starting current	A	0.60 / 0.60			0.80 / 0.80		1.00 / 1.00
Appearance			Zinc hot dipping steel plate					
Outer dimension	Height	mm	600			600		
	Width	mm	745			1,045		
	Depth	mm	220			220		
Total weight		kg	21			28		
Heat exchanger			Finned tube					
Soundproof/Heat-insulating material			Non-flammable insulation					
Fan unit	Fan		Centrifugal fan					
	Standard air flow (High/Mid./Low)	m <sup>3</sup> /h	460 / 400 / 300			740 / 600 / 490		950 / 790 / 640
	Motor output	W	19			70		
	Static pressure	Pa	0 (*2)					
Air filter			Standard filter (Simple filter)					
Controller			Remote controller (Sold separately)					
Connecting pipe	Gas side	mm	Dia. 9.5			Dia. 12.7		Dia. 15.9
	Liquid side		Dia. 6.4					Dia. 9.5
	Drain port (Nominal dia.)		20 (polyvinyl chloride tube)					
Sound pressure level (High/Mid./Low)		dB(A)	36 / 34 / 32					42 / 37 / 33

### Note

(\*1) Rated conditions    Cooling : Indoor 27 °C Dry Bulb / 19 °C Wet Bulb, Outdoor 35 °C Dry Bulb.  
 Heating : Indoor 20 °C Dry Bulb, Outdoor 7 °C Dry Bulb / 6 °C Wet Bulb.  
 Based on equivalent piping length of 7.5 m and piping height difference of 0 m.

(\*2) This model cannot be used with external static pressure.

## 1-6. Floor standing type



Model name		MMF-	UP0151H-E(TR)	UP0181H-E(TR)	UP0241H-E(TR)	UP0271H-E(TR)	UP0361H-E(TR)	UP0481H-E(TR)	UP0561H-E(TR)
Cooling/Heating capacity (*1)		kW	4.5 / 5.0	5.6 / 6.3	7.1 / 8.0	8.0 / 9.0	11.2 / 12.5	14.0 / 16.0	16.0 / 18.0
Electical characteristics	Power supply		220-240V ~ 50Hz / 208-230V ~ 60Hz						
	Running current	A	0.37 / 0.38		0.55 / 0.58		0.82 / 0.86	0.97 / 1.02	
	Power consumption	kW	0.053 / 0.053		0.087 / 0.087		0.133 / 0.133	0.158 / 0.158	
	Starting current	A	0.48 / 0.50		0.71 / 0.75		1.06 / 1.11	1.27 / 1.33	
Appearance			Silky shade (Munsell 1Y 8.5 / 8.0)						
Outer dimension	Height	mm	1,750				1,750		
	Width	mm	600				600		
	Depth	mm	210				390		
Total weight		kg	46		47		61		
Heat exchanger			Finned tube						
Soundproof/Heat-insulating material			Non-flammable insulation						
Fan unit	Fan		Centrifugal fan						
	Standard air flow (H/M+/M/L+/L)	m <sup>3</sup> /h	820/760/700/640/600		930/830/770/700/640		1660/1550/1420/1190/1170	1760/1630/1480/1370/1350	
	Motor output	W	62				109		
Air filter			Standard filter (Simple filter)						
Controller			Remote controller (Sold separately)						
Connecting pipe	Gas side	mm	Dia. 12.7		Dia. 15.9				
	Liquid side	mm	Dia. 6.4		Dia. 9.5				
	Drain port (Nominal dia.)	mm	20 (polyvinyl chloride tube)						
Sound pressure level (H/M+/M/L+/L)		dB(A)	46 / 44 / 42 / 40 / 38		50 / 47 / 45 / 43 / 41		51 / 49 / 46 / 44 / 41	53 / 51 / 48 / 46 / 45	

### Note

(\*1) Rated conditions    Cooling : Indoor 27 °C Dry Bulb / 19 °C Wet Bulb, Outdoor 35 °C Dry Bulb.  
 Heating : Indoor 20 °C Dry Bulb, Outdoor 7 °C Dry Bulb / 6 °C Wet Bulb.  
 Based on equivalent piping length of 7.5 m and piping height difference of 0 m.







MMU-UP0181WH-E(TR), UP0241WH-E(TR), UP0271WH-E(TR), UP0301WH-E(TR)

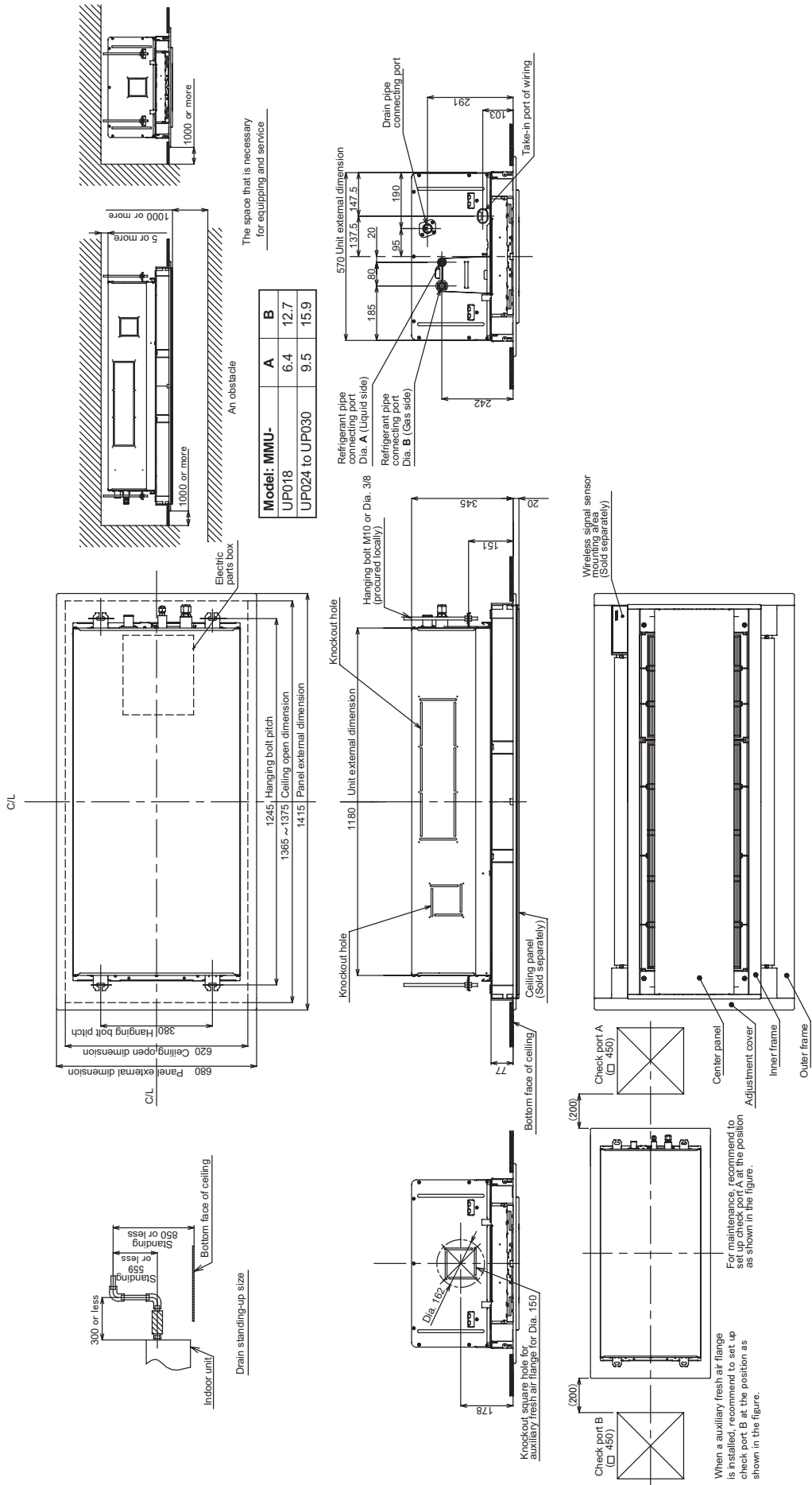

(Unit : mm)



## 2-3. 1-way cassette (SH) type

MMU-UP0151SH-E(TR), UP0181SH-E(TR), UP0241SH-E(TR)

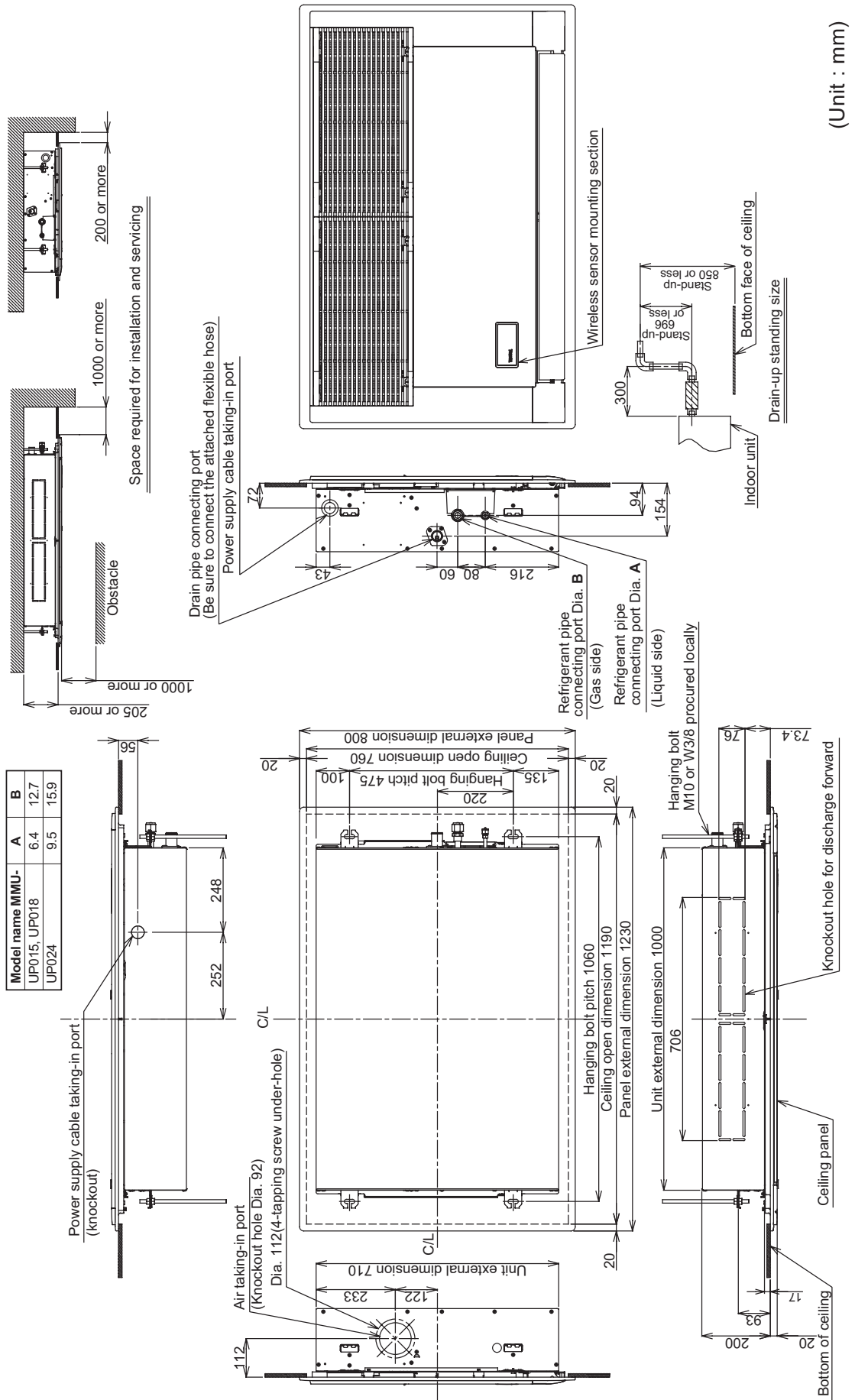

(Unit : mm)

## 2-4. Floor standing cabinet type

MML-UP0071H-E(TR), UP0091H-E(TR), UP0121H-E(TR), UP0151H-E(TR), UP0181H-E(TR), UP0241H-E(TR)

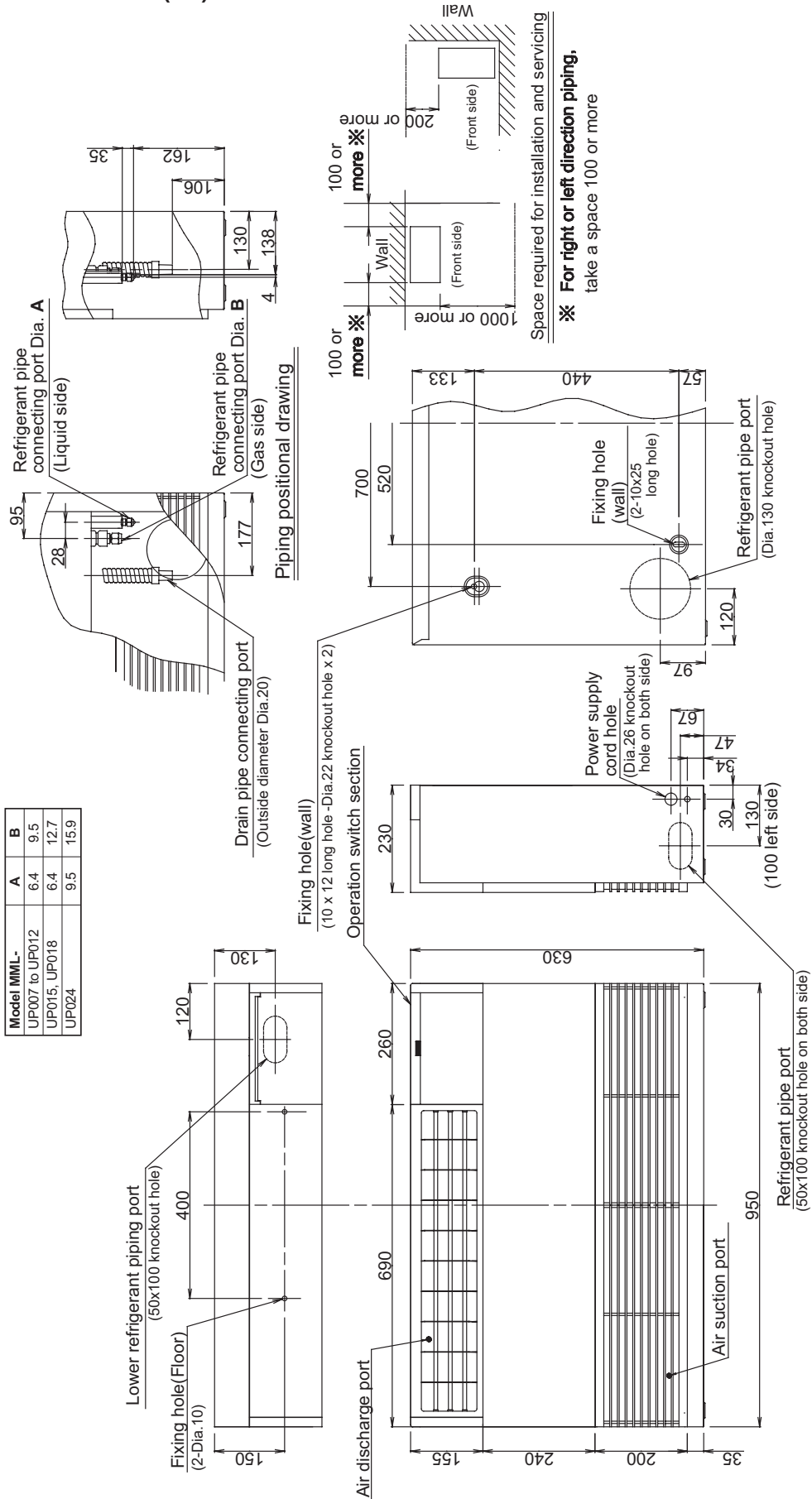

Model	MML-	A	B
UP007 to UP012		6.4	9.5
UP015, UP018		6.4	12.7
UP024		9.5	15.9

(Unit:mm)



MML-UP0151BH-E(TR), UP0181BH-E(TR), UP0241BH-E(TR)

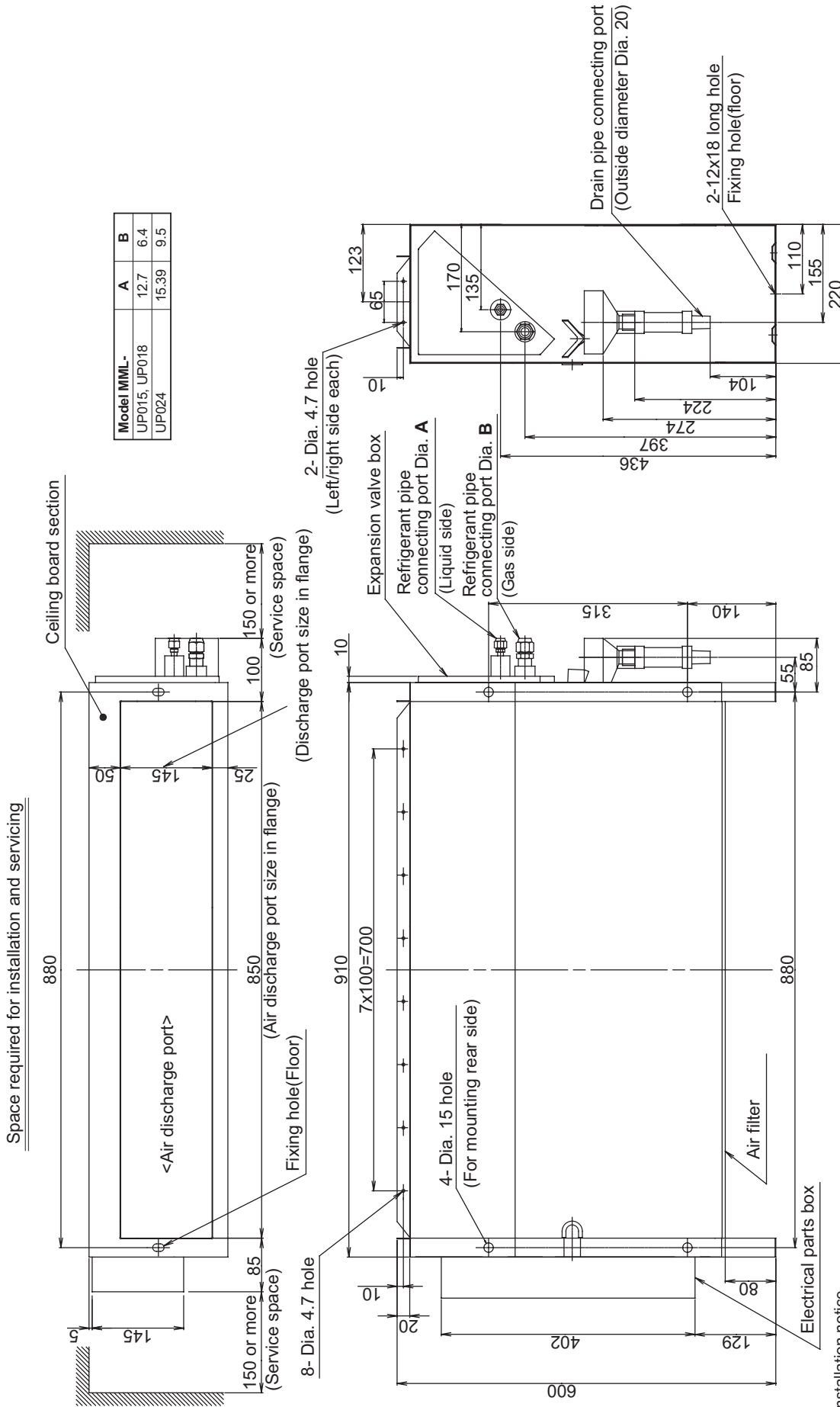

Installation notice

1. Please secure an enough suction space not to be trouble in suction air flow.
2. The drain filter to prevent drain clogging is attached in this indoor unit. It might become clogging condition with garbages or foreign matters during the installation, due to set it outside of the unit. So be sure to clean the drain filter before test run. Moreover be sure to clean it in the regular check.
3. This model is a concealed type. Therefore conceal other parts than the air outlet and the air filter. Be sure not to touch the electric parts box, the surrounding lead wires, the refrigerant pipes, etc. directly with the hands.

(Unit : mm)





MMF-UP0361H-E(TR), UP0481H-E(TR), UP0561H-E(TR)

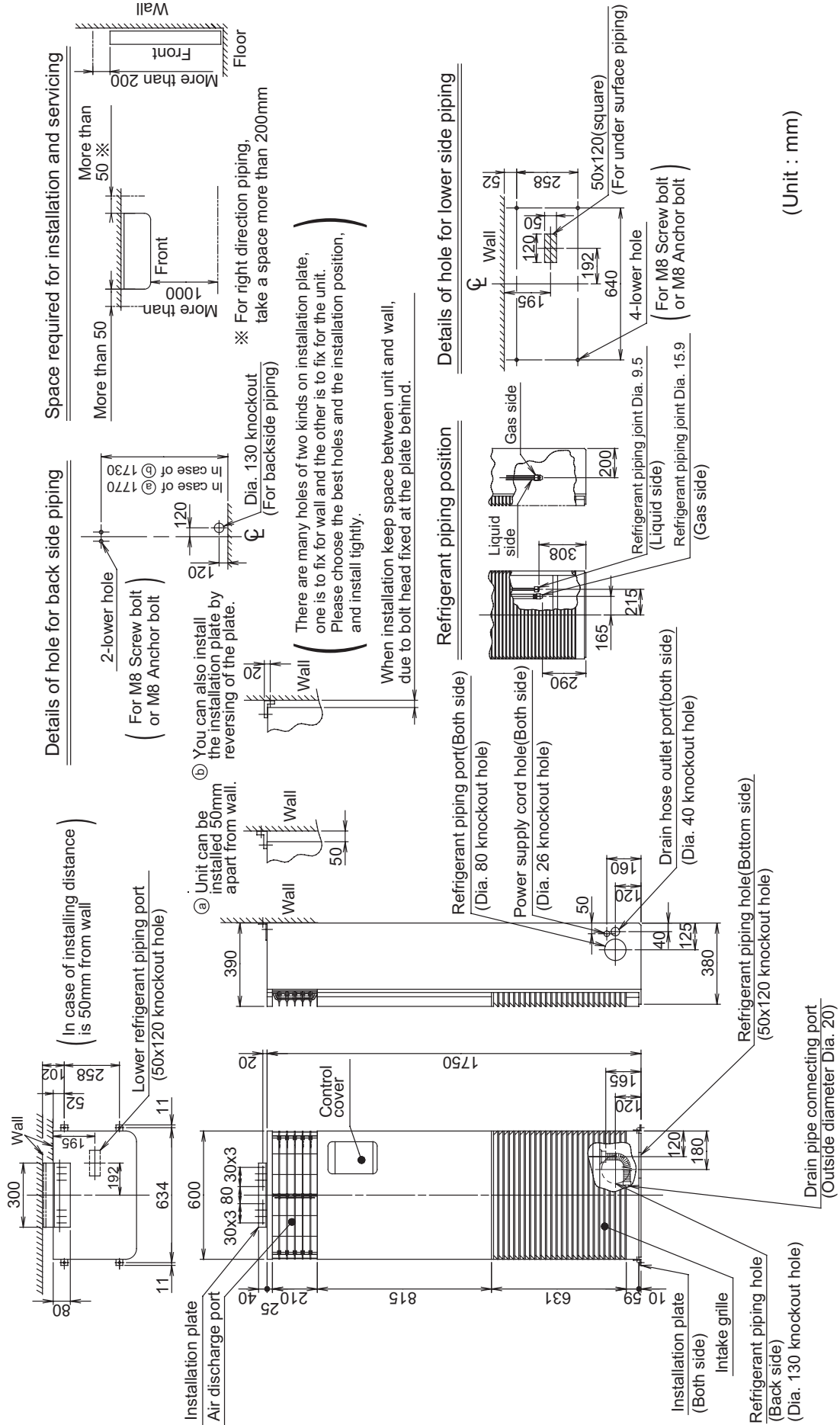

(Unit : mm)

# 3. WIRING DIAGRAMS

## 3-1. Compact 4-way cassette type

MMU- UP0051MH-E(TR), UP0071MH-E(TR), UP0091MH-E(TR), UP0121MH-E(TR),  
UP0151MH-E(TR), UP0181MH-E(TR)

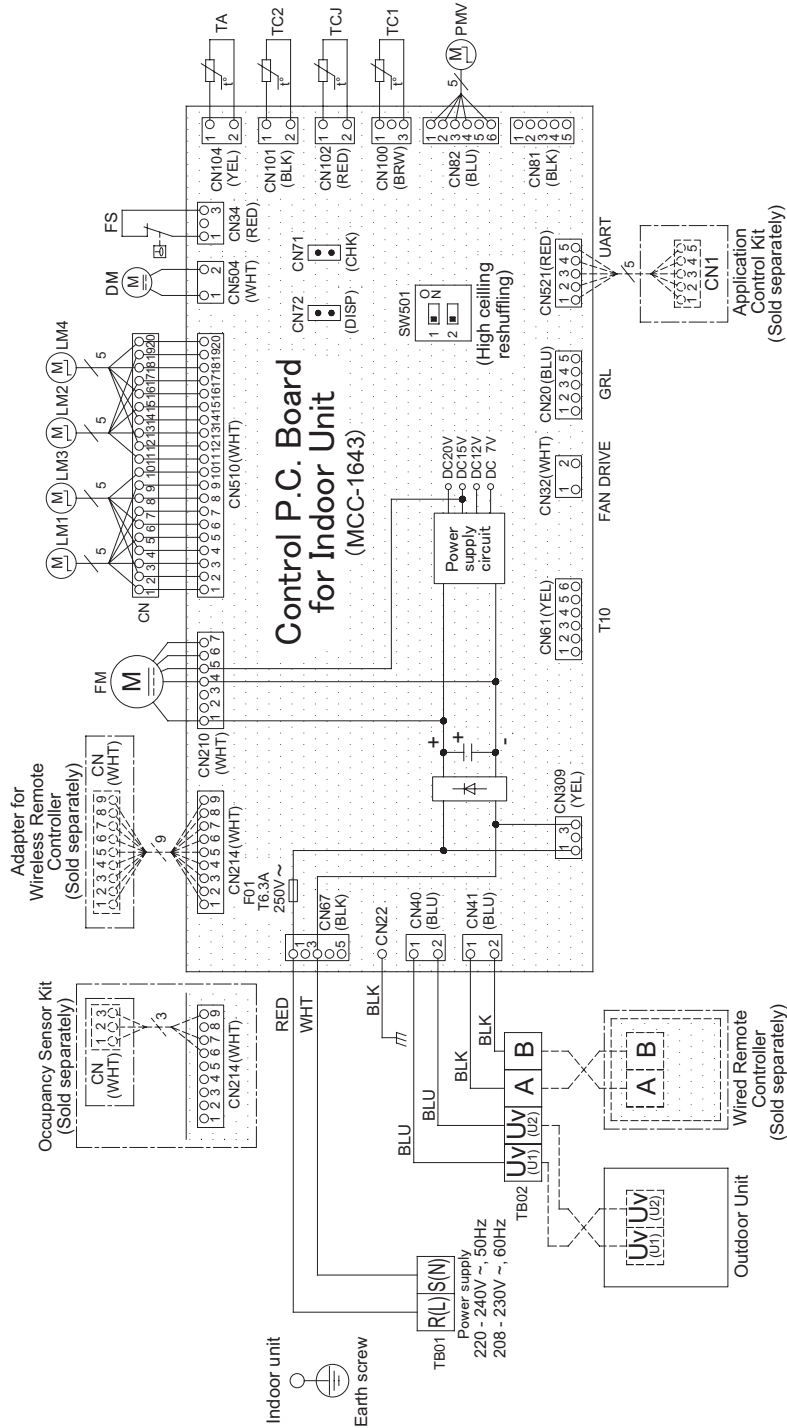

Color	Indication
RED	Red
WHT	White
YEL	Yellow
BLU	Blue
BLK	Black
GRN	Green
BRW	Brown

Symbol	Field Wiring
⊕	Protection Ground
□	Terminal Block
○	Terminal
⊡	Connector
⊞	P.C.Board
---	Accessory

Symbol	Parts Name
CN * *	Connector
DM	Drain Pump Motor
F01	Fuse
FM	Fan Motor
FS	Floater Switch
LM1,2,3,4	Louver Motor
PMV	Pulse Motor Valve
SW501	Dip Switch
TA	Indoor Temp Sensor
TB01,02	Terminal Block
TC1,2,TCJ	Temp Sensor

## 3-2. 2-way cassette type

MMU-UP0071WH-E(TR), UP0091WH-E(TR), UP0121WH-E(TR), UP0151WH-E(TR),  
UP0181WH-E(TR), UP0241WH-E(TR), UP0271WH-E(TR), UP0301WH-E(TR),  
UP0361WH-E(TR), UP0481WH-C, UP0561WH-E(TR)

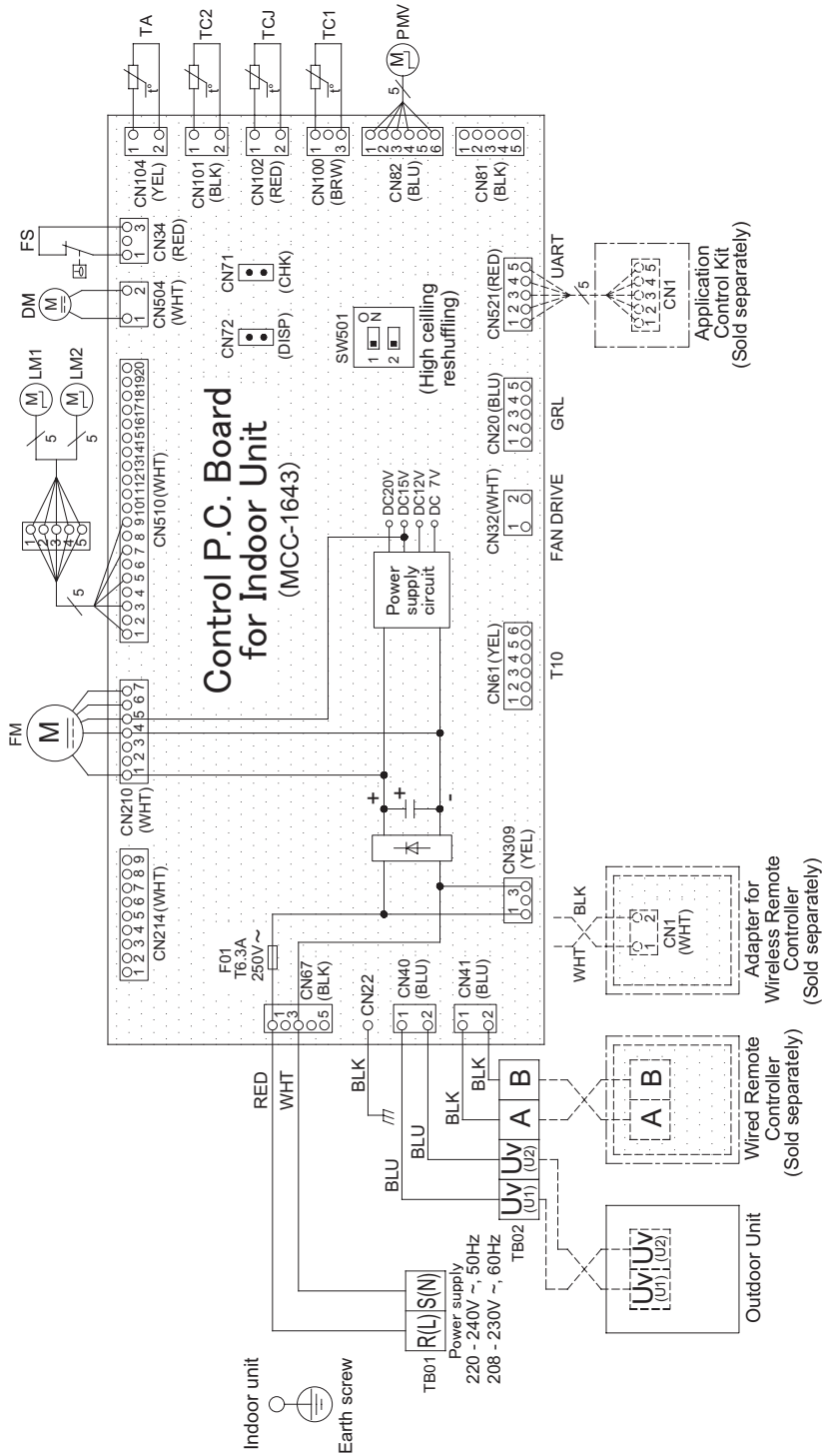

Color Indication

RED:Red
WHT:White
YEL:Yellow
BLU:Blue
BLK:Black
GRN:Green
BRW:Brown

Field Wiring
Protection Ground
Terminal Block
Terminal
Connector
P.C.Board
Accessory

Symbol	Parts Name
CN # *	Connector
DM	Drain Pump Motor
F01	Fuse
FM	Fan Motor
FS	Float Switch
LM1,2	Louver Motor
PMV	Pulse Motor Valve
SW501	Dip Switch
TA	Indoor Temp Sensor
TB01,02	Terminal Block
TC1,2,TCJ	Temp Sensor

### 3-3. 1-way cassette (SH) type

MMU-UP0151SH-E(TR), UP0181SH-E(TR), UP0241SH-E(TR)

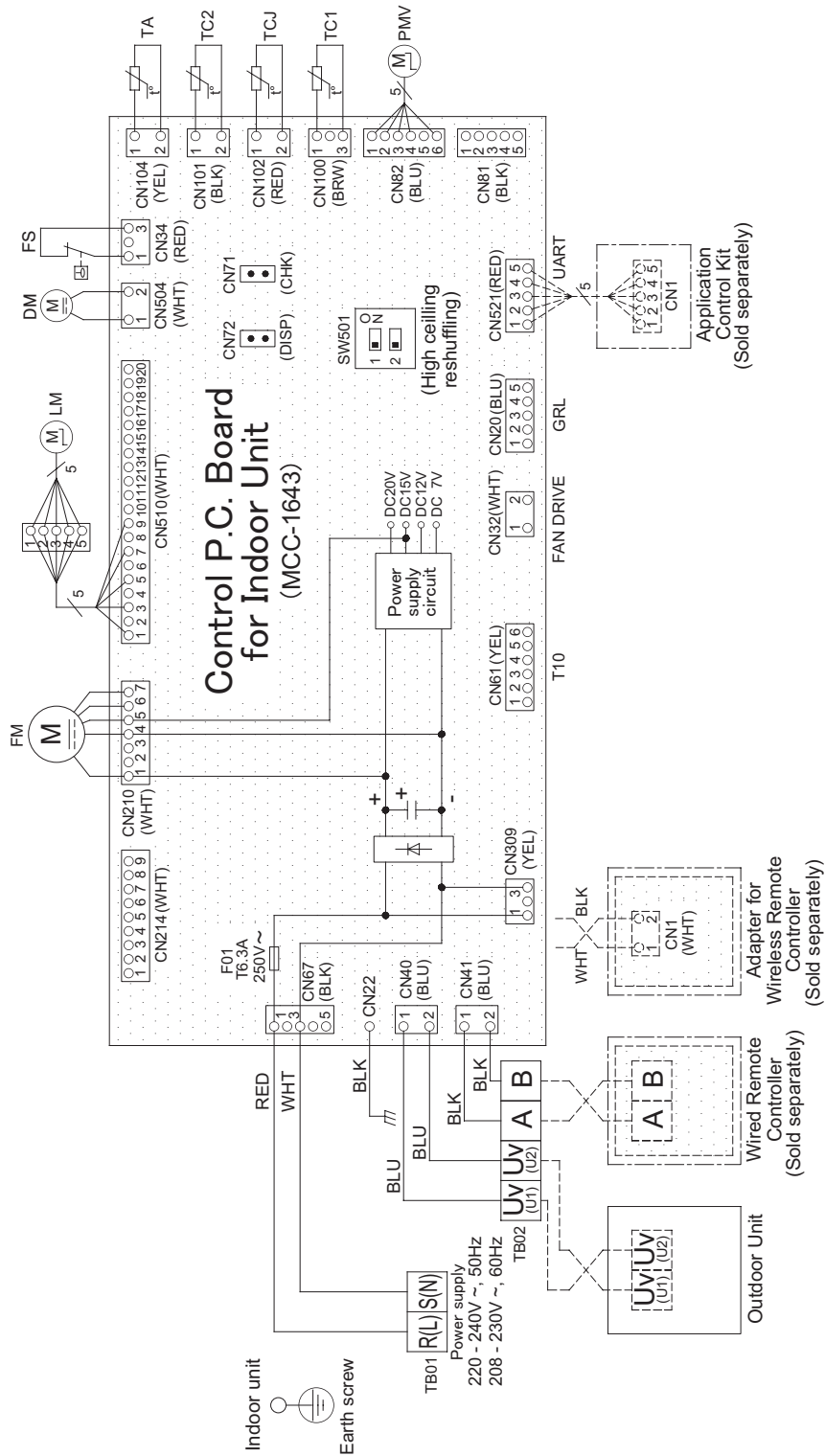

Color Indication	
RED	:Red
WHT	:White
YEL	:Yellow
BLU	:Blue
BLK	:Black
GRN	:Green
BRW	:Brown

---	Field Wiring
⊕	Protection Ground
□	Terminal Block
○	Terminal
○	Connector
□	P.C.Board
---	Accessory

Symbol	Parts Name
CN * *	Connector
DM	Drain Pump Motor
F01	Fuse
FM	Fan Motor
FS	Float Switch
LM	Louver Motor
PMV	Pulse Motor Valve
SW501	Dip Switch
TA	Indoor Temp Sensor
TB01,02	Terminal Block
TC1,2,TCJ	Temp Sensor

### 3-4. Floor standing cabinet type

MML-UP0071H-E(TR), UP0091H-E(TR), UP0121H-E(TR), UP0151H-E(TR), UP0181H-E(TR), UP0241H-E(TR)

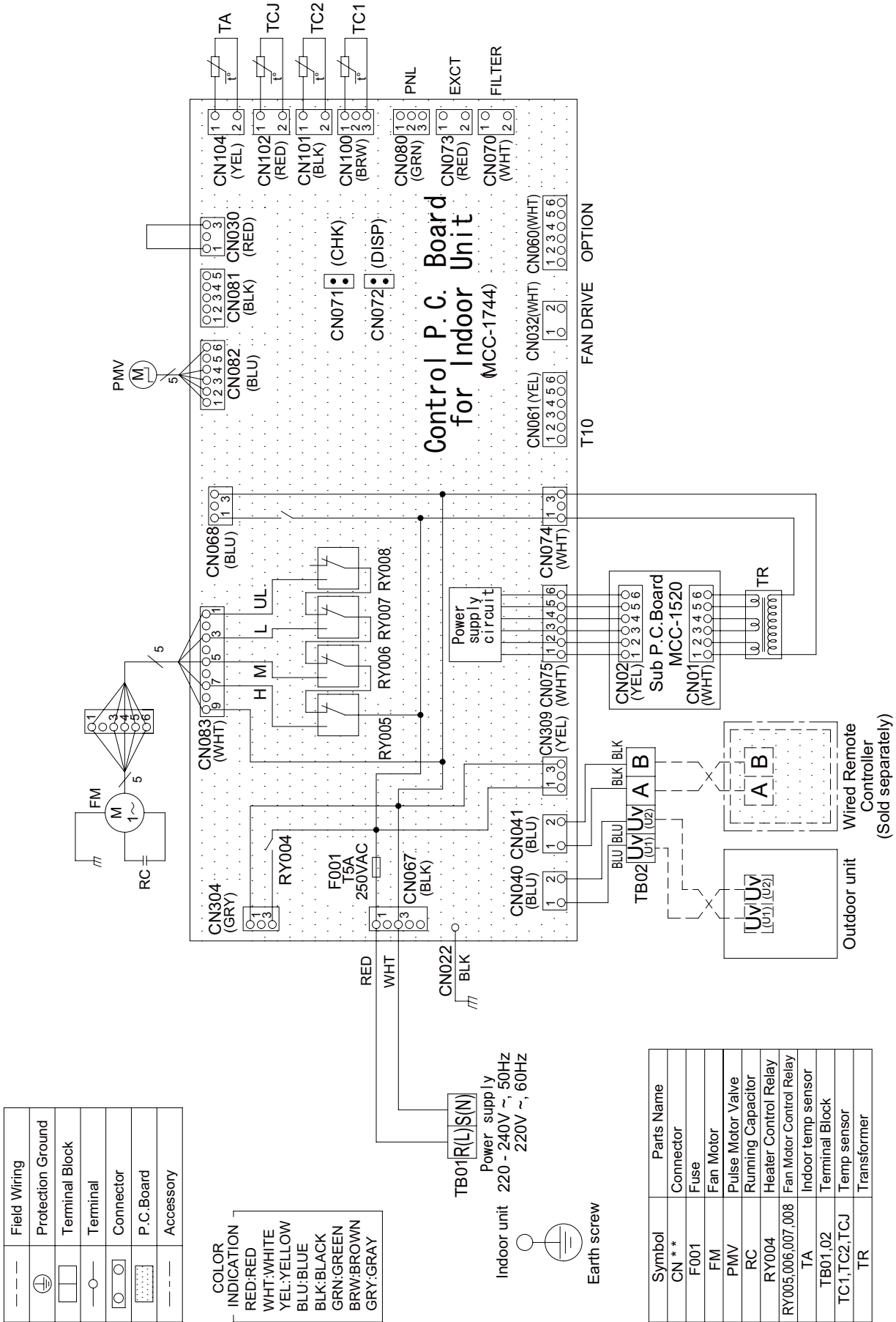

### 3-5. Floor standing concealed type

MML- UP0071BH-E(TR), UP0091BH-E(TR), UP0121BH-E(TR), UP0151BH-E(TR),  
UP0181BH-E(TR), UP0241BH-E(TR)

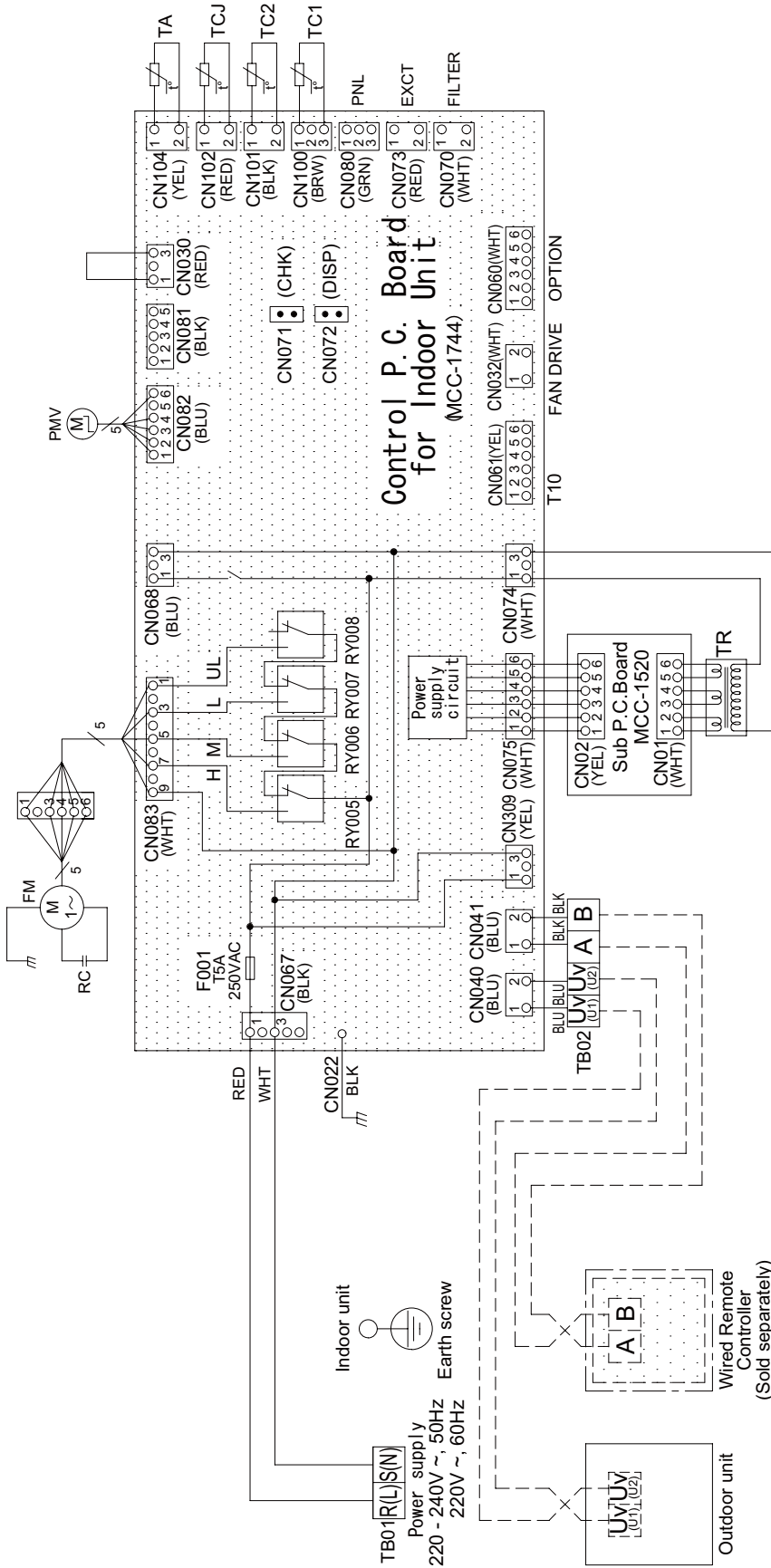

**COLOR INDICATION**

RED: RED
WHT: WHITE
YEL: YELLOW
BLU: BLUE
BLK: BLACK
GRN: GREEN
BRW: BROWN

Symbol	Parts Name
CN * *	Connector
F001	Fuse
FM	Fan Motor
PMV	Pulse Motor Valve
RC	Running Capacitor
RY005,006,007,008	Fan Motor Control Relay
TA	Indoor temp sensor
TB01.02	Terminal Block
TC1,TC2,TCJ	Temp sensor
TR	Transformer

---	Field Wiring
⊕	Protection Ground
□	Terminal Block
○	Terminal
○	Connector
□	P.C. Board
---	Accessory

### 3-6. Floor standing type

MMF-UP0151H-E(TR), UP0181H-E(TR), UP0241H-E(TR), UP0271H-E(TR), UP0361H-E(TR), UP0481H-E(TR), UP0561H-E(TR)

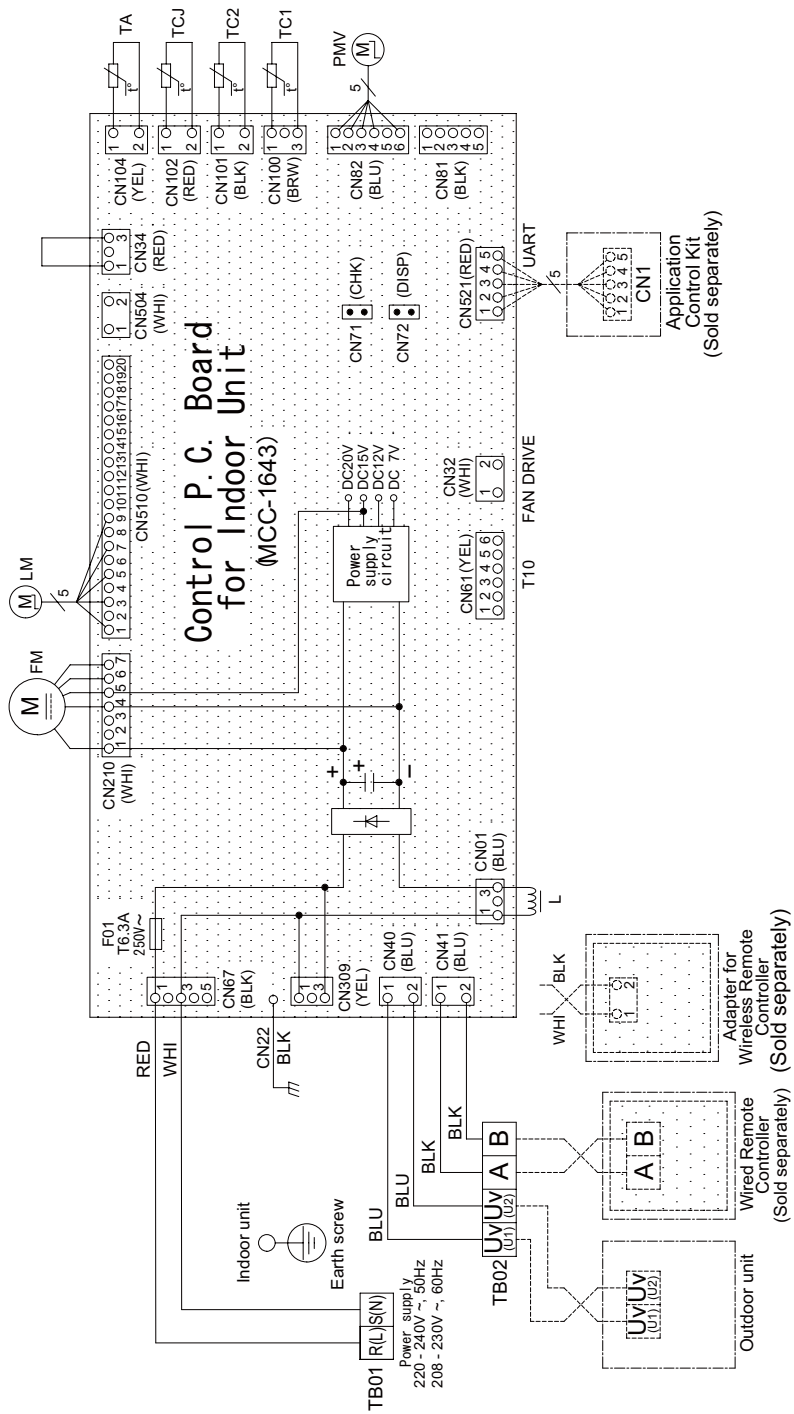

**COLOR INDICATION**

RED: RED  
WHI: WHITE  
YEL: YELLOW  
BLU: BLUE  
BLK: BLACK  
BRW: BROWN

	Field Wiring
	Protection Ground
	Terminal Block
	Terminal
	Connector
	P.C. Board
	Accessory

Symbol	Parts Name
CN**	Connector
F01	Fuse
FM	Fan Motor
L	Reactor
LM	Louver Motor
PMV	Pulse Motor Valve
TA	Indoor temp sensor
TB01,02	Terminal Block
TC1,TC2,TCJ	Temp sensor



## 4. PARTS RATING

### Indoor unit

#### Compact 4-way cassette type

Model	MMU-UP***MH-E(TR)	005	007	009	012	015	018	
Fan motor		ICF-340D60-1						
Drain pump motor		MDP-1401						
Float switch		FS-0218-102						
Pulse motor valve		PAM-B25YGTF-1			PAM-B40YGTF-1			
P.C. board		MCC-1643						
TA sensor		Lead wire length: 818 mm Vinyl tube						
TC1 sensor		Dia.4 size lead wire length: 400 mm Vinyl tube						
TC2 sensor		Dia.6 size lead wire length: 500 mm Vinyl tube (Black)						
TCJ sensor		Dia.6 size lead wire length: 400 mm Vinyl tube (Red)						

#### 2-way cassette type

Model	MMU-UP***WH-E(TR)	007	009	012	015	018	024	027	030	036	048	056
Fan motor		ICF-340D60-1			ICF-340WD94-9			ICF-340WD139-3				
Drain pump motor		ADP-1409										
Float switch		FS-0218-103										
Pulse motor valve		PAM-B25YGTF-1		PAM-B40YGTF-2				PAM-B60YGTF-1				
P.C. board		MCC-1643										
TA sensor		Lead wire length : 268 mm										
TC1 sensor		Dia.4 size lead wire length : 1200 mm vinyl tube (Blue)										
TC2 sensor		Dia.6 size lead wire length : 1200 mm vinyl tube (Black)										
TCJ sensor		Dia.6 size lead wire length : 1200 mm vinyl tube (Red)										

#### 1-way cassette type

Model	MMU-UP***SH-E(TR)	015	018	024
Fan motor		ICF-340WD94-9		
Drain pump motor		ADP-1409		
Float switch		FS-0218-103		
Pulse motor valve		PAM-B40YGTF-1		
P.C. board		MCC-1643		
TA sensor		Lead wire length: 155 mm Vinyl tube		
TC1 sensor		Dia.4 size lead wire length: 1100 mm Vinyl tube (Blue)		
TC2 sensor		Dia.6 size lead wire length: 1100 mm Vinyl tube (Black)		
TCJ sensor		Dia.6 size lead wire length: 1100 mm Vinyl tube (Red)		

#### Floor standing cabinet type

Model	MML-UP***H-E(TR)	007	009	012	015	018	024
Fan motor		SWA-200A4A		AF-200-45-4F		AF200-70-4K	
Running capacitor for fan motor		AC450 V, 1.2 $\mu$ F		AC400 V, 1.8 $\mu$ F		AC450 V, 2 $\mu$ F	
Pulse motor valve		PAM-B25YGTF-1		PAM-B40YGTF-1			
P.C. board		MCC-1744					
TA sensor		Lead wire length: 818 mm Vinyl tube					
TC1 sensor		Dia.4 size lead wire length: 1200 mm Vinyl tube (Blue)					
TC2 sensor		Dia.6 size lead wire length: 1200 mm Vinyl tube (Black)					
TCJ sensor		Dia.6 size lead wire length: 1200 mm Vinyl tube (Red)					

#### Floor standing concealed type

Model	MML-UP***BH-E(TR)	007	009	012	015	018	024	
Fan motor		SWA-200A4B			AF-200-70-4K			
Running capacitor for fan motor		AC450 V, 1.5 $\mu$ F			AC450 V, 3 $\mu$ F		AC450 V, 2 $\mu$ F	
Pulse motor valve		PAM-B25YGTF-1			PAM-B40YGTF-1			
P.C. board		MCC-1744						
TA sensor		Lead wire length: 818 mm Vinyl tube						
TC1 sensor		Dia.4 size lead wire length: 2000 mm Vinyl tube (Blue)						
TC2 sensor		Dia.6 size lead wire length: 2000 mm Vinyl tube (Black)						
TCJ sensor		Dia.6 size lead wire length: 2000 mm Vinyl tube (Red)						

#### Floor standing type

Model	MMF-UP***H-E(TR)	015	018	024	027	036	048	056	
Fan motor		ICF-340D62-1			ICF-340WD109-1				
Pulse motor valve		PAM-B40YGTF-1			PAM-B60YGTF-1				
P.C. board		MCC-1643							
TA sensor		Lead wire length: 1200 mm Vinyl tube							
TC1 sensor		Dia.4 size lead wire length: 1200 mm Vinyl tube (Blue)							
TC2 sensor		Dia.6 size lead wire length: 2000 mm Vinyl tube (Black)							
TCJ sensor		Dia.6 size lead wire length: 1200 mm Vinyl tube (Red)							

# 5. REFRIGERANT CYCLE DIAGRAM

## Indoor unit

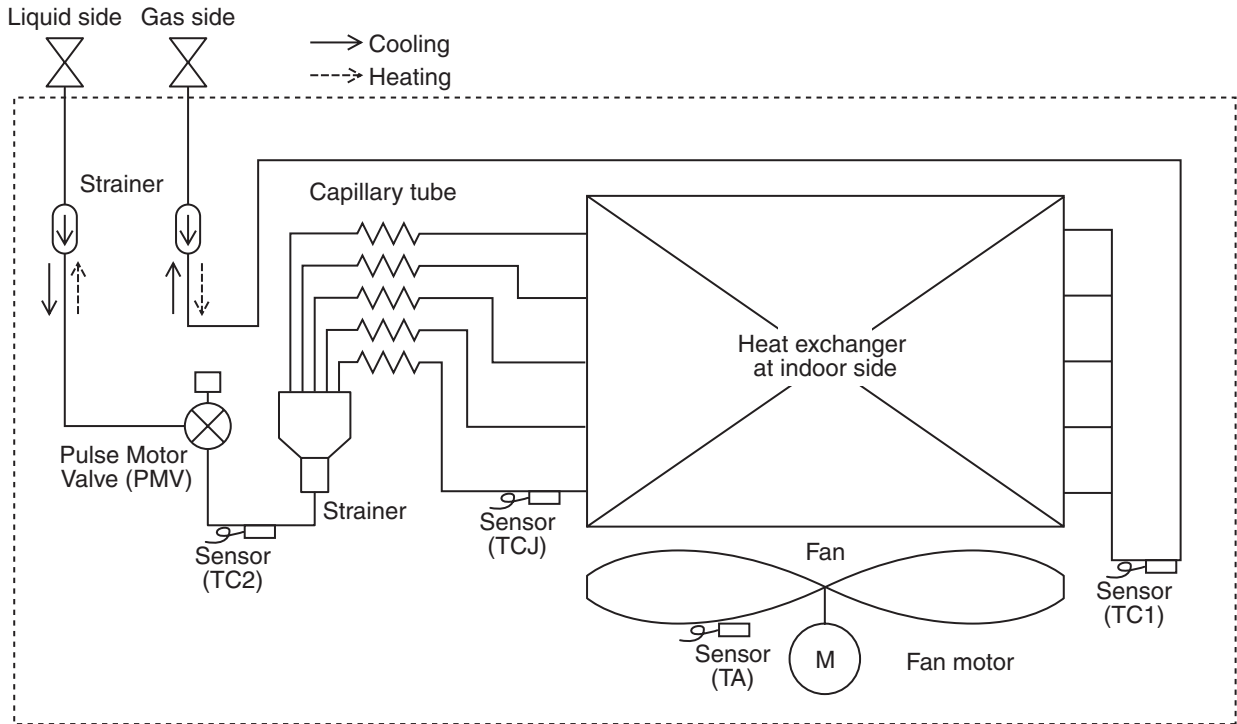

### Explanation of functional parts in indoor unit

Functional part name		Functional outline
Pulse Motor Valve	PMV	(Connector CN82 (6P): Blue) 1) Controls superheat in cooling operation 2) Controls subcool in heating operation 3) Recovers refrigerant oil in cooling operation 4) Recovers refrigerant oil in heating operation
Temp. Sensor	TA	(Connector CN104 (2P): Yellow) 1) Detects indoor suction temperature
	TC1	(Connector CN100 (3P): Brown) 1) Controls PMV superheat in cooling operation
	TC2	(Connector CN101 (2P): Black) 1) Controls PMV subcool in heating operation
	TCJ	(Connector CN102 (2P): Red) 1) Controls PMV superheat in cooling operation

# 6. CONTROL OUTLINE

## Control Specifications

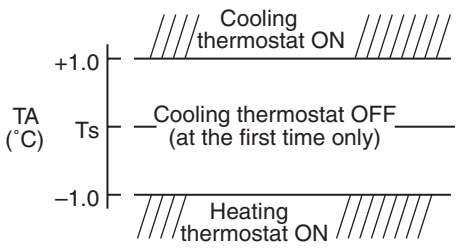
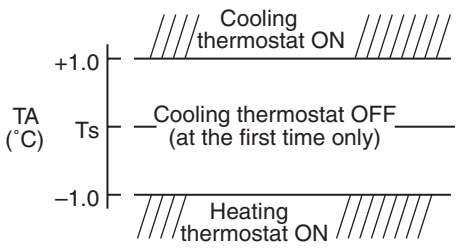
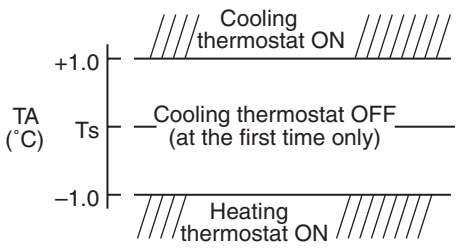
No.	Item	Outline of specifications	Remarks														
1	When power supply is reset	1) Distinction of outdoor unit When the power supply is reset, the outdoors are distinguished and the control is selected according to the distinguished result. 2) Setting of indoor fan speed and existence of air direction adjustment Based on EEPROM data, select setting of the indoor fan speed and the existence of air direction adjustment. 3) If resetting the power supply during occurrence of a trouble, the check code is once cleared. After ON/OFF button of the remote controller was pushed and the operation was resumed, if the abnormal status continues, the check code is again displayed on the remote controller.															
2	Operation mode selection	1) Based on the operation mode selecting command from the remote controller, the operation mode is selected. <table border="1" style="margin: 10px auto; width: 80%;"> <thead> <tr> <th>Remote controller command</th> <th>Control outline</th> </tr> </thead> <tbody> <tr> <td>STOP</td> <td>Operation stops.</td> </tr> <tr> <td>FAN</td> <td>Fan operation</td> </tr> <tr> <td>COOL</td> <td>Cooling operation</td> </tr> <tr> <td>DRY</td> <td>Dry operation</td> </tr> <tr> <td>HEAT</td> <td>Heating operation</td> </tr> <tr> <td>AUTO Heat recovery system outdoor unit type</td> <td> <ul style="list-style-type: none"> <li>TA and Ts automatically select COOL/HEAT operation mode for operation.</li> <li>The operation is performed as shown in the following figure according to TA value at the first time only. (In the range of <math>T_s - 1 &lt; TA &lt; T_s + 1</math>, Cooling thermostat OFF (Fan) / Setup air volume operation continues.)</li> </ul>  </td> </tr> </tbody> </table> <p>* Heat recovery system outdoor unit type can select automatic mode.            While a wireless remote controller is used, the mode is notified by "Pi Pi" (two times) receiving sound and the alternate flashing of [TIMER ☹] and [READY ☺].            To clear the alternate flashing, change the mode on the wireless remote controller.</p>	Remote controller command	Control outline	STOP	Operation stops.	FAN	Fan operation	COOL	Cooling operation	DRY	Dry operation	HEAT	Heating operation	AUTO Heat recovery system outdoor unit type	<ul style="list-style-type: none"> <li>TA and Ts automatically select COOL/HEAT operation mode for operation.</li> <li>The operation is performed as shown in the following figure according to TA value at the first time only. (In the range of <math>T_s - 1 &lt; TA &lt; T_s + 1</math>, Cooling thermostat OFF (Fan) / Setup air volume operation continues.)</li> </ul> 	TA: Room temp. Ts: Setup temp.
Remote controller command	Control outline																
STOP	Operation stops.																
FAN	Fan operation																
COOL	Cooling operation																
DRY	Dry operation																
HEAT	Heating operation																
AUTO Heat recovery system outdoor unit type	<ul style="list-style-type: none"> <li>TA and Ts automatically select COOL/HEAT operation mode for operation.</li> <li>The operation is performed as shown in the following figure according to TA value at the first time only. (In the range of <math>T_s - 1 &lt; TA &lt; T_s + 1</math>, Cooling thermostat OFF (Fan) / Setup air volume operation continues.)</li> </ul> 																
3	Room temp. control	1) Adjustment range: Remote controller setup temperature (°C) <table border="1" style="margin: 10px auto; width: 80%;"> <thead> <tr> <th></th> <th>COOL/DRY</th> <th>HEAT</th> <th>AUTO*</th> </tr> </thead> <tbody> <tr> <td>Wired type</td> <td>18 to 29</td> <td>18 to 29</td> <td>18 to 29</td> </tr> <tr> <td>Wireless type</td> <td>17 to 30</td> <td>17 to 30</td> <td>17 to 30</td> </tr> </tbody> </table>		COOL/DRY	HEAT	AUTO*	Wired type	18 to 29	18 to 29	18 to 29	Wireless type	17 to 30	17 to 30	17 to 30	Heat recovery system outdoor unit type		
	COOL/DRY	HEAT	AUTO*														
Wired type	18 to 29	18 to 29	18 to 29														
Wireless type	17 to 30	17 to 30	17 to 30														

No.	Item	Outline of specifications	Remarks																
3	Room temp. control (Continued)	<p>2) By setting the CODE No. 06, the setup temperature in heating operation can be compensated.</p> <table border="1" data-bbox="448 286 1099 371"> <thead> <tr> <th>Setup data</th> <th>0</th> <th>2</th> <th>4</th> <th>6</th> </tr> </thead> <tbody> <tr> <td>Setup temp. compensation</td> <td>+0°C</td> <td>+2°C</td> <td>+4°C</td> <td>+6°C</td> </tr> </tbody> </table> <p>The initial factory default value</p> <table border="1" data-bbox="448 427 1099 577"> <thead> <tr> <th>Model</th> <th>Set data</th> </tr> </thead> <tbody> <tr> <td>Floor standing cabinet, Floor standing concealed, Floor standing</td> <td>0</td> </tr> <tr> <td>Other models</td> <td>2</td> </tr> </tbody> </table>	Setup data	0	2	4	6	Setup temp. compensation	+0°C	+2°C	+4°C	+6°C	Model	Set data	Floor standing cabinet, Floor standing concealed, Floor standing	0	Other models	2	<p>Return air temperature shift of heating operation</p> <p>Except while sensor of the remote controller is controlled (Code No. [32], "0001")</p>
Setup data	0	2	4	6															
Setup temp. compensation	+0°C	+2°C	+4°C	+6°C															
Model	Set data																		
Floor standing cabinet, Floor standing concealed, Floor standing	0																		
Other models	2																		
4	Automatic capacity control	<p>1) Based on the difference between TA and Ts, the operation capacity is determined by the outdoor unit.</p> <div style="display: flex; justify-content: space-around;"> <div data-bbox="464 779 730 1160"> <p><b>COOL</b></p> </div> <div data-bbox="815 779 1082 1160"> <p><b>HEAT</b></p> </div> </div>	<p>Ts: Setup temp. TA: Room temp.</p>																
5	Automatic cooling/heating control	<p>1) The judgment of selecting COOL/HEAT is carried out as shown below. When TA exceeds Tsh by 1.5 for 10 minutes, the operation is thermostat OFF then, the heating operation (thermostat OFF) is changed to cooling operation.</p> <div style="text-align: center;"> </div> <p>Description in the parentheses shows an example of cooling ON/OFF. When TA is less than Tsh by 1.5 for 10 minutes, the operation is thermostat OFF then, the cooling operation(thermostat OFF) is changed to heating operation.</p> <p>2) For the automatic capacity control after judgment of cooling/heating, refer to item No.4.</p> <p>3) For temperature compensation of room temp. control in automatic heating, refer to item No.3.</p>	<p>* Heat recovery system outdoor unit type system only</p> <p>Tsc: Setup temp. in cooling operation</p> <p>Tsh: Setup temp. in heating operation + temp. compensation of room temp. control</p>																

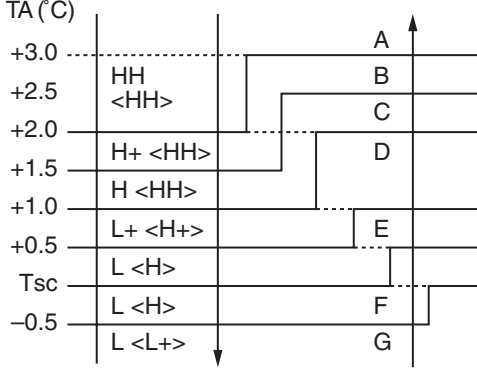
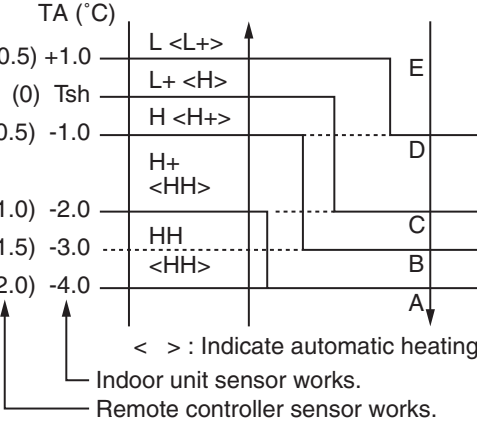



No.	Item	Outline of specifications	Remarks
6	Fan speed selection	<p>1) By the command from remote control, fan speed is changed. ((HH), (H+), (H), (L+), (L) or [AUTO])</p> <p>2) When the fan speed mode [AUTO] is selected, the fan speed varies by the difference between TA and Ts.</p> <p><b>&lt;COOL&gt;</b></p>  <p style="text-align: center;">&lt; &gt; : Indicate automatic cooling.</p> <ul style="list-style-type: none"> <li>• Fan speed mode [AUTO] in case when remote controller sensor works is equal to that in case when indoor unit sensor works.</li> <li>• If the fan speed has been changed once, it is not changed for 3 minutes. However when the air volume is changed, the fan speed changes.</li> <li>• When cooling operation has started, select a downward slope for the fan speed, that is, the high position.</li> <li>• If the temperature is just on the difference boundary, the fan speed is not changed.</li> </ul> <p><b>&lt;HEAT&gt;</b></p>  <p style="text-align: center;">&lt; &gt; : Indicate automatic heating.</p> <p style="text-align: center;">( ) : indicate the value when the remote controller sensor is worked.</p> <ul style="list-style-type: none"> <li>• If the fan speed has been changed once, it is not changed for 1 minute. However when the fan speed changed, the fan speed changes.</li> <li>• When heating operation has started, select an upward slope for the fan speed, that is, the high position.</li> <li>• If the temperature is at the difference boundary, the fan speed is not changed.</li> <li>• If TC2 ≥ 60°C, the fan speed increases by 1 step.</li> </ul>	<p>HH &gt; H+ &gt; H &gt; L+ &gt; L &gt; UL</p> <p>Depends on fan speed mode selection at the remote controller. (H+) and (L+) cannot be selected.</p> <p>For Floor Standing Concealed Type, or Floor Standing Cabinet Type, (HH), (H), (L) or [AUTO] can be selected regardless of remote controller models.</p> <p>Code No. [32]  0000: Indoor unit sensor (Main unit)  0001: Remote controller sensor</p> <p>TC2: Temperature of indoor heat exchanger sensor</p>



No.	Item	Outline of specifications	Remarks																																																																																																																																																																																																										
6	Fan speed selection (Continued):	<p><b>Compact 4-way (only UP015), 2-way, 1-way (SH)</b> (Fan speed selection of UP012 or less and UP018 for Compact 4-way are only Standard.)</p> <table border="1"> <thead> <tr> <th rowspan="2">CODE No. [5d]</th> <th colspan="2">Factory default</th> <th colspan="2">Type 1</th> <th colspan="2">Type 3</th> <th colspan="2">Type 6</th> </tr> <tr> <th colspan="2">0000</th> <th colspan="2">0001</th> <th colspan="2">0003</th> <th colspan="2">0006</th> </tr> <tr> <th>SW501 (1)/(2)</th> <th colspan="2">OFF/OFF</th> <th colspan="2">ON/OFF</th> <th colspan="2">OFF/ON</th> <th colspan="2">ON/ON</th> </tr> <tr> <th>Tap</th> <th>COOL</th> <th>HEAT</th> <th>COOL</th> <th>HEAT</th> <th>COOL</th> <th>HEAT</th> <th>COOL</th> <th>HEAT</th> </tr> </thead> <tbody> <tr><td>F1</td><td></td><td></td><td></td><td></td><td>HH</td><td>HH</td><td>HH</td><td>HH</td></tr> <tr><td>F2</td><td></td><td></td><td>HH</td><td>HH</td><td></td><td></td><td></td><td></td></tr> <tr><td>F3</td><td></td><td></td><td></td><td>H+</td><td>H+, H</td><td>H+, H</td><td>H+, H, L+, L</td><td>H+, H, L+, L</td></tr> <tr><td>F4</td><td></td><td></td><td>H+</td><td></td><td></td><td></td><td></td><td></td></tr> <tr><td>F5</td><td></td><td>HH</td><td></td><td>H</td><td></td><td></td><td></td><td></td></tr> <tr><td>F6</td><td>HH</td><td></td><td>H</td><td></td><td>L+</td><td>L+</td><td></td><td></td></tr> <tr><td>F7</td><td>H+</td><td>H+</td><td></td><td></td><td>L</td><td>L</td><td></td><td></td></tr> <tr><td>F8</td><td></td><td>H</td><td></td><td>L+</td><td></td><td></td><td></td><td></td></tr> <tr><td>F9</td><td>H</td><td></td><td>L+</td><td>L</td><td></td><td></td><td></td><td></td></tr> <tr><td>FA</td><td></td><td>L+</td><td>L</td><td></td><td></td><td></td><td></td><td></td></tr> <tr><td>FB</td><td>L+</td><td>L</td><td></td><td></td><td></td><td></td><td></td><td></td></tr> <tr><td>FC</td><td>L</td><td></td><td></td><td></td><td></td><td></td><td></td><td></td></tr> <tr><td>FD</td><td>LL</td><td>LL</td><td>LL</td><td>LL</td><td>LL</td><td>LL</td><td>LL</td><td>LL</td></tr> </tbody> </table> <p><b>Floor standing</b></p> <table border="1"> <thead> <tr> <th rowspan="2">CODE No. [5d]</th> <th colspan="2">Factory default</th> </tr> <tr> <th colspan="2">0000</th> </tr> <tr> <th>SW501 (1)/(2)</th> <th colspan="2">OFF/OFF</th> </tr> <tr> <th>Tap</th> <th>COOL</th> <th>HEAT</th> </tr> </thead> <tbody> <tr><td>F1</td><td></td><td></td></tr> <tr><td>F2</td><td></td><td></td></tr> <tr><td>F3</td><td></td><td></td></tr> <tr><td>F4</td><td></td><td></td></tr> <tr><td>F5</td><td></td><td>HH</td></tr> <tr><td>F6</td><td>HH</td><td></td></tr> <tr><td>F7</td><td>H+</td><td>H+</td></tr> <tr><td>F8</td><td></td><td>H</td></tr> <tr><td>F9</td><td>H</td><td></td></tr> <tr><td>FA</td><td></td><td>L+</td></tr> <tr><td>FB</td><td>L+</td><td>L</td></tr> <tr><td>FC</td><td>L</td><td></td></tr> <tr><td>FD</td><td>LL</td><td>LL</td></tr> </tbody> </table>	CODE No. [5d]	Factory default		Type 1		Type 3		Type 6		0000		0001		0003		0006		SW501 (1)/(2)	OFF/OFF		ON/OFF		OFF/ON		ON/ON		Tap	COOL	HEAT	COOL	HEAT	COOL	HEAT	COOL	HEAT	F1					HH	HH	HH	HH	F2			HH	HH					F3				H+	H+, H	H+, H	H+, H, L+, L	H+, H, L+, L	F4			H+						F5		HH		H					F6	HH		H		L+	L+			F7	H+	H+			L	L			F8		H		L+					F9	H		L+	L					FA		L+	L						FB	L+	L							FC	L								FD	LL	LL	LL	LL	LL	LL	LL	LL	CODE No. [5d]	Factory default		0000		SW501 (1)/(2)	OFF/OFF		Tap	COOL	HEAT	F1			F2			F3			F4			F5		HH	F6	HH		F7	H+	H+	F8		H	F9	H		FA		L+	FB	L+	L	FC	L		FD	LL	LL	Setting of height ceiling mode at CODE No. [5D] or at SW501 on P.C. board.
CODE No. [5d]	Factory default			Type 1		Type 3		Type 6																																																																																																																																																																																																					
	0000		0001		0003		0006																																																																																																																																																																																																						
SW501 (1)/(2)	OFF/OFF		ON/OFF		OFF/ON		ON/ON																																																																																																																																																																																																						
Tap	COOL	HEAT	COOL	HEAT	COOL	HEAT	COOL	HEAT																																																																																																																																																																																																					
F1					HH	HH	HH	HH																																																																																																																																																																																																					
F2			HH	HH																																																																																																																																																																																																									
F3				H+	H+, H	H+, H	H+, H, L+, L	H+, H, L+, L																																																																																																																																																																																																					
F4			H+																																																																																																																																																																																																										
F5		HH		H																																																																																																																																																																																																									
F6	HH		H		L+	L+																																																																																																																																																																																																							
F7	H+	H+			L	L																																																																																																																																																																																																							
F8		H		L+																																																																																																																																																																																																									
F9	H		L+	L																																																																																																																																																																																																									
FA		L+	L																																																																																																																																																																																																										
FB	L+	L																																																																																																																																																																																																											
FC	L																																																																																																																																																																																																												
FD	LL	LL	LL	LL	LL	LL	LL	LL																																																																																																																																																																																																					
CODE No. [5d]	Factory default																																																																																																																																																																																																												
	0000																																																																																																																																																																																																												
SW501 (1)/(2)	OFF/OFF																																																																																																																																																																																																												
Tap	COOL	HEAT																																																																																																																																																																																																											
F1																																																																																																																																																																																																													
F2																																																																																																																																																																																																													
F3																																																																																																																																																																																																													
F4																																																																																																																																																																																																													
F5		HH																																																																																																																																																																																																											
F6	HH																																																																																																																																																																																																												
F7	H+	H+																																																																																																																																																																																																											
F8		H																																																																																																																																																																																																											
F9	H																																																																																																																																																																																																												
FA		L+																																																																																																																																																																																																											
FB	L+	L																																																																																																																																																																																																											
FC	L																																																																																																																																																																																																												
FD	LL	LL																																																																																																																																																																																																											
		3)In heating operation, the mode changes to [LL] if thermostat is turned off.																																																																																																																																																																																																											





No.	Item	Outline of specifications	Remarks															
7	Prevention of cold air discharge	<p>1. In heating operation, the lowest temperature between TC1 sensor and the highest temperature between TC2 and TCJ sensor is set as the upper bound of the fan speed mode control.</p> <ul style="list-style-type: none"> <li>When B zone has been continuing for 6 minutes, the operation shifts to C zone.</li> <li>For the defrosting operation, the control point is set to +6°C.</li> </ul> <p style="margin-left: 40px;"> A zone: OFF  B zone: Over 26°C, below 28°C, ULTRA LOW (LL)  C zone: Over 28°C, below 30°C, LOW (L)  D zone: Over 30°C, below 32°C, MED (H)  E zone: HIGH (HH) </p>	TCJ: Temperature of indoor heat exchanger sensor <ul style="list-style-type: none"> <li>In D and E zones, priority is given to remote controller fan speed setup.</li> <li>In A zone “” is displayed.</li> </ul>															
8	Freeze prevention control (Low temp. release)	<p>1. In all cooling operation, the air conditioner operates as described below based upon temp. detected by TC1, TC2 and TCJ sensors.</p> <ul style="list-style-type: none"> <li>When “J” zone is detected for 5 minutes, the thermostat is forcedly off.</li> <li>In “K” zone, the timer count is interrupted, and held.</li> <li>When “I” zone is detected, the timer is cleared and the operation returns to the normal operation.</li> <li>If “J” zone continues, operation of the indoor fan in LOW mode continues until it reaches the “I” zone. It is reset when the following conditions are satisfied.</li> </ul> <p><b>Reset conditions</b></p> <ol style="list-style-type: none"> <li>TC1 ≥ 12°C and TC2 ≥ 12°C and TCJ ≥ 12°C</li> <li>20 minutes passed after stop.</li> </ol> <table border="1" style="margin-left: 40px;"> <thead> <tr> <th></th> <th>TC1</th> <th>TC2, TCJ</th> </tr> </thead> <tbody> <tr> <td>P1</td> <td>10°C (5°C)</td> <td>-10°C</td> </tr> <tr> <td>Q1</td> <td>0°C</td> <td>-14°C</td> </tr> </tbody> </table> <p>2. In all cooling operation, the air conditioner operates as described below based upon temp. detected by TC2 and TCJ sensors.</p> <ul style="list-style-type: none"> <li>When “M” zone is detected for 45 minutes, the thermostat is forcedly off.</li> <li>In “N” zone, the timer count is interrupted and held.</li> <li>When shifting to “M” zone again, the timer count restarts and continues.</li> <li>If “L” zone is detected, the timer is cleared and the operation returns to normal operation.</li> </ul> <p><b>Reset conditions</b></p> <ol style="list-style-type: none"> <li>TC1 ≥ 12°C and TC2 ≥ 12°C and TCJ ≥ 12°C</li> <li>20 minutes passed after stop.</li> </ol> <table border="1" style="margin-left: 40px;"> <thead> <tr> <th></th> <th>TC2, TCJ</th> </tr> </thead> <tbody> <tr> <td>P2</td> <td>5°C</td> </tr> <tr> <td>Q2</td> <td>-2.0°C</td> </tr> </tbody> </table>		TC1	TC2, TCJ	P1	10°C (5°C)	-10°C	Q1	0°C	-14°C		TC2, TCJ	P2	5°C	Q2	-2.0°C	TC1: Temperature of indoor heat exchanger sensor <p><b>( ) value:</b>  When the power supply is turned on, the forced thermostat becomes OFF if the temperature is less than this indicated temperature.</p>
	TC1	TC2, TCJ																
P1	10°C (5°C)	-10°C																
Q1	0°C	-14°C																
	TC2, TCJ																	
P2	5°C																	
Q2	-2.0°C																	

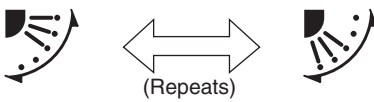



No.	Item	Outline of specifications	Remarks
9	Refrigerant (Oil) recovery control in cooling operation	<p>Indoor units during stop/thermostat OFF or FAN operation perform following controls when a refrigerant (compressor oil) recovery signal is received from outdoor unit at the cooling operation,</p> <ol style="list-style-type: none"> <li>(1) Opening the indoor unit PMV at constant valve opening. (For a maximum of about 4 minutes)</li> <li>(2) Operating the drain pump for about one minute, during recovery control and after the control finished.</li> </ol> <p>Also, indoor unit fan or louvers may operate depending on the indoor unit type.</p>	Control is performed per two hours or when the outdoor unit determines its need.(It varies depending on the indoor units connected.)
10	Refrigerant (Oil) recovery control in heating operation	<p>Indoor units during stop/thermostat OFF or FAN operation perform following controls when a refrigerant (compressor oil) recovery signal is received from outdoor unit at the heating operation,</p> <ol style="list-style-type: none"> <li>(1) Opening the indoor unit PMV at constant valve opening. (For a maximum of about 20 minutes)</li> <li>(2) TC2 temperature is detected to close its PMV.</li> </ol> <p>Also, the fan, louvers, drain pump may operate for about one minute after recovery control finished depending on indoor unit types, until the number of recovery control reaches the predetermined number.</p> <p>NOTE The PMV, indoor fan, or louvers may operate through the outdoor unit instruction. For its detail, refer to the outdoor unit service guide.</p>	<p>Indoor unit during cooling thermostat OFF or FAN operation stops the indoor fan and displays "Operation standby ☺".</p> <p>Control is performed per one hour or when the outdoor unit determines its need.(It varies depending on the indoor units connected.)</p>
11	Compensation control for short intermittent operation	<ol style="list-style-type: none"> <li>1) For 3 minutes after start of operation, the operation is forcedly continued even if the unit enters in Thermostat-OFF condition.</li> <li>2) However the thermostat is OFF giving prior to COOL/HEAT selection, READY ☼ for operation and protective control.</li> </ol>	Usually the priority is given to 5 minutes at outdoor controller side.
12	Drain pump control	<ol style="list-style-type: none"> <li>1) Drain pump operates while in cooling operation. (including DRY operation)</li> <li>2) While the drain pump is operating, if the float switch is operated, the outdoor unit will stop operating but the drain pump will keep continuously operating. After that, the check code is issued.</li> <li>3) When the drain pump stops operating, if the float switch is operated, the outdoor unit will stop and the drain pump will start operating. After the float switch is being operating for roughly 5 minutes, the check code will be issued.</li> </ol>	<p>Check Code [P10]</p> <ul style="list-style-type: none"> <li>• A model with a drain pump : Compact 4-way 2-way cassette 1-way cassette (SH)</li> </ul>
13	Elimination of retained heat	<ol style="list-style-type: none"> <li>1) When the unit stopped from [HEAT] operation, the indoor fan operates with [L] for approx. 30 seconds.</li> </ol>	
14	HA control	<ol style="list-style-type: none"> <li>1) ON/OFF operation is available by input of HA signal from the remote site when connecting to remote controller or the remote ON/OFF interface.</li> <li>2) The HA terminal is ON/OFF depending on HA control output.</li> <li>3) The I/O specifications of HA is in accordance with JEMA standard.</li> </ol>	<p>When using HA terminal (CN61) for the remote ON/OFF, a connector sold separately is necessary.</p> <p>In case of group operation, use the connector to connect HA terminal to either master or follower indoor unit.</p>

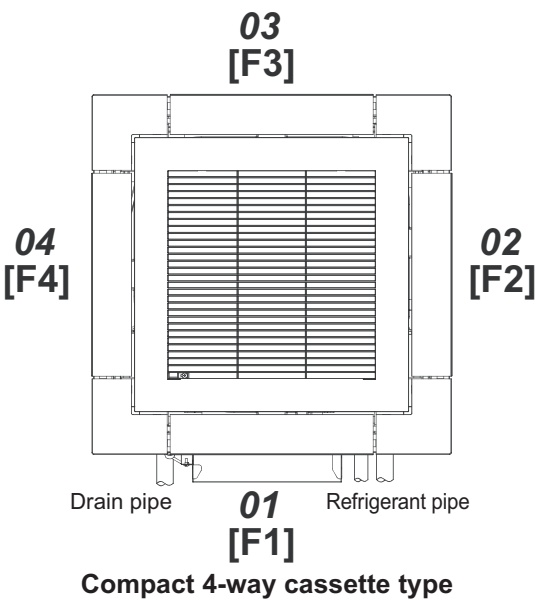

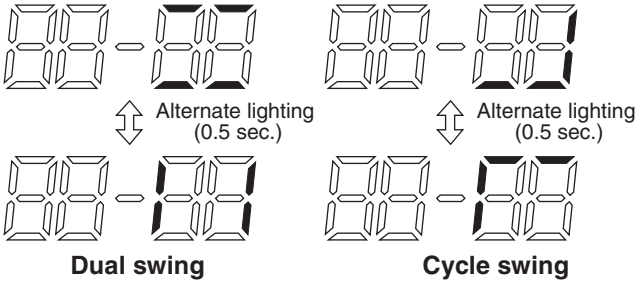

No.	Item	Outline of specifications	Remarks																																																
15	Alarm output setup	<p>The alarm output from the indoor P.C. board is output in each indoor unit during group control, but it can be set so as to be output in the header unit and follower units.</p> <p>Following the table below, register the setting data in DN Code "79".</p> <table border="1"> <thead> <tr> <th>DN</th> <th>Alarm output of the header indoor unit</th> <th>Setting data</th> </tr> </thead> <tbody> <tr> <td rowspan="2">79</td> <td>Not including the state of follower units</td> <td>0000 (Factory default)</td> </tr> <tr> <td>Including the state of follower units</td> <td>0001</td> </tr> </tbody> </table>	DN	Alarm output of the header indoor unit	Setting data	79	Not including the state of follower units	0000 (Factory default)	Including the state of follower units	0001	<p>Connector CN61 (Refer to 8-3-1,8-3-2. Optional connector specifications of indoor P.C. board (MCC-1643, MCC-1744)</p> <p>Be sure to change the setting data while operation stops.</p>																																								
DN	Alarm output of the header indoor unit	Setting data																																																	
79	Not including the state of follower units	0000 (Factory default)																																																	
	Including the state of follower units	0001																																																	
16	Display of filter sign [  ] (Not provided to the wireless type)	<p>1) The filter sign is displayed with LC by sending the filter-reset signal to the remote controller when the specified time (150H/2500H) elapsed as a result of integration of the operation time of the indoor fan.</p> <p>2) The integrated timer is cleared when the filter-reset signal is received from the remote controller. In this time, if the specified time elapsed, the counted time is reset and the liquid crystal display is deleted.</p> <table border="1"> <thead> <tr> <th>Filter service life</th> <th>2500H</th> <th>150H</th> </tr> </thead> <tbody> <tr> <td>Type</td> <td>Compact 4-way cassette type 1-way cassette type (SH) 2-way cassette type</td> <td>Floor standing type Floor standing concealed type Floor standing cabinet type</td> </tr> </tbody> </table>	Filter service life	2500H	150H	Type	Compact 4-way cassette type 1-way cassette type (SH) 2-way cassette type	Floor standing type Floor standing concealed type Floor standing cabinet type	<p>[  FILTER ] goes on. The filter sign is not displayed in RBC-ASCU11-*. </p>																																										
Filter service life	2500H	150H																																																	
Type	Compact 4-way cassette type 1-way cassette type (SH) 2-way cassette type	Floor standing type Floor standing concealed type Floor standing cabinet type																																																	
17	Display of [READY] [HEAT READY]	<p><b>&lt; READY &gt;</b> Displayed on the remote controller</p> <p>1) When the following check codes are indicated</p> <ul style="list-style-type: none"> <li>• Open phase of power supply wiring [P05] was detected.</li> <li>• There is an indoor unit that detected the indoor overflow [P10].</li> <li>• There is an indoor unit that detected the interlock alarm [L30].</li> </ul> <p>2) During Force Thermostat-OFF</p> <ul style="list-style-type: none"> <li>• [COOL/DRY] operation is unavailable because the other indoor unit operates with [HEAT] mode.</li> <li>• [HEAT] operation is unavailable because COOL priority (SW11-bit1 of the Outdoor I/F P.C. board is ON) is set and the other indoor unit operates with [COOL/DRY] mode.</li> </ul> <p>3) When the indoor unit which is in the condition of 1) or 2) keeps being in thermostat OFF status.</p> <p>4) The indoor fan stops because the system performs [Recovery operation for heating refrigerant (Oil)].</p> <p><b>&lt;HEAT READY &gt;</b> Displayed on the remote controller</p> <p>The indoor fan stops in order to prevent discharge of cool air when heating operation started or during heating operation. (including the defrost operation during thermostat-OFF)</p>	<ul style="list-style-type: none"> <li>• <b>&lt; READY &gt;</b>  display</li> <li>No display for wireless type remote controller</li> <li>• <b>&lt;HEAT READY &gt;</b>  display</li> </ul>																																																
18	Selection of central control mode	<p>1) Selection of the contents that can be operated by the remote controller at the indoor unit side is possible according to setting at the central controller side.</p> <p>2) Setting contents</p> <table border="1"> <thead> <tr> <th rowspan="2">Operation from central controller</th> <th colspan="6">Operation on remote controller</th> </tr> <tr> <th>ON/OFF setting</th> <th>Operation selection</th> <th>Timer setting</th> <th>Temp. setting</th> <th>Fan speed setting</th> <th>Air direction setting</th> </tr> </thead> <tbody> <tr> <td>Individual</td> <td>○</td> <td>○</td> <td>○</td> <td>○</td> <td>○</td> <td>○</td> </tr> <tr> <td>[Central 1]</td> <td>×</td> <td>○</td> <td>×</td> <td>○</td> <td>○</td> <td>○</td> </tr> <tr> <td>[Central 2]</td> <td>×</td> <td>×</td> <td>×</td> <td>×</td> <td>○</td> <td>○</td> </tr> <tr> <td>[Central 3]</td> <td>○</td> <td>×</td> <td>○</td> <td>×</td> <td>○</td> <td>○</td> </tr> <tr> <td>[Central 4]</td> <td>○</td> <td>×</td> <td>○</td> <td>○</td> <td>○</td> <td>○</td> </tr> </tbody> </table> <p>(○: Operation possible ×: Operation impossible)</p>	Operation from central controller	Operation on remote controller						ON/OFF setting	Operation selection	Timer setting	Temp. setting	Fan speed setting	Air direction setting	Individual	○	○	○	○	○	○	[Central 1]	×	○	×	○	○	○	[Central 2]	×	×	×	×	○	○	[Central 3]	○	×	○	×	○	○	[Central 4]	○	×	○	○	○	○	
Operation from central controller	Operation on remote controller																																																		
	ON/OFF setting	Operation selection	Timer setting	Temp. setting	Fan speed setting	Air direction setting																																													
Individual	○	○	○	○	○	○																																													
[Central 1]	×	○	×	○	○	○																																													
[Central 2]	×	×	×	×	○	○																																													
[Central 3]	○	×	○	×	○	○																																													
[Central 4]	○	×	○	○	○	○																																													

No.	Item	Outline of specifications	Remarks
19	Louver control	<p>1) Louver position setup</p> <ul style="list-style-type: none"> <li>When the louver position is changed, the position moves necessarily to downward discharge position once to return to the set position.</li> <li>The louver position can be set up in the following operation range.</li> </ul> <p><b>In cooling/dry operation</b>                      <b>In heating/fan operation</b></p>  <ul style="list-style-type: none"> <li>In group twin/triple operation, the louver positions can be set up collectively or individually.</li> <li>In case that HEAT refrigerant recovery control was performed in STOP status, the louver position becomes horizontal when the operation is resumed.</li> </ul> <p>2) Swing setup Compact 4-way, 2-way cassette, 1-way cassette (SH) :</p> <ul style="list-style-type: none"> <li>[SWING] is displayed and the following display is repeated.</li> </ul> <p><b>In all operations</b></p>  <ul style="list-style-type: none"> <li>In group operation, the louver positions can be set up collectively or individually.</li> </ul> <p>Floor standing :</p> <ul style="list-style-type: none"> <li>[SWING] is displayed and the following display is repeated.</li> </ul> <p><b>In all operations</b></p>  <ul style="list-style-type: none"> <li>As for Floor standing, the vertical louver operates to a horizontal direction. (Perform vertical wind direction adjustment manually)</li> <li>In group operation, the louver positions can be set up collectively or individually.</li> </ul> <p>3) When the unit stopped or the warning was output, the louver is automatically set to full closed position.</p> <p>4) When PRE-HEAT (Heating ready) is displayed (Heating operation started or defrost operation is performed), heating thermostat is off or self-cleaning is performed, the louver is automatically set to horizontal discharge position.</p> <p>* The louver which air direction is individually set or the locked louver closes fully when the unit stops and the louver is automatically set to horizontal discharge position when PRE-HEAT (Heating ready) is displayed, heating thermostat is off.</p>	Subject model : Compact 4-way 2-way cassette 1-way cassette (SH)

No.	Item	Outline of specifications	Remarks
19	Louver control (Continued)	<p><b>&lt;&lt;Individual air direction setup&gt;&gt;</b></p> <ul style="list-style-type: none"> <li>Pushing  Louver select button enables every discharge port to set up the air direction. The louver numbers that are displayed on the display part correspond to those in the following figure.</li> <li>In case of no input (key operation) for approx. 5 seconds during setting of individual air direction (during displaying of louver No. on the remote controller screen), the remote controller screen returns to the normal display screen.</li> <li>For the air direction illustration during normal operation, the air direction of the least No. among the louvers which are block-set is displayed.</li> <li>While individual air direction is being set, the remote controller operation (Illustration of air direction) and operation of the real machine are linked.</li> <li>When selecting a case,  Louver select button is not pushed or louver No. is not displayed, the air directions of all the louvers are collectively set up.</li> </ul> <div style="text-align: center;">  <p><b>03 [F3]</b></p> <p><b>04 [F4]</b>      <b>02 [F2]</b></p> <p>Drain pipe      <b>01 [F1]</b>      Refrigerant pipe</p> <p><b>Compact 4-way cassette type</b></p> </div>	<p>Subject model : Compact 4-way</p> <p>Setup from the remote controller without  button is unavailable.</p>

No.	Item	Outline of specifications	Remarks														
19	Louver control (Continued)	<p><b>&lt;&lt;Selection of Swing mode&gt;&gt;</b></p> <ul style="list-style-type: none"> <li>For the Swing mode, the following three types of modes are selectable and settable by keeping Swing/Direction  button pushed for 4 seconds or more on the remote controller. (In the case of RBC-AMT***) Swing mode can be selected by Code No.(DN) setup [F0] (In the case of RBC-ASCU11-*).</li> </ul> <ol style="list-style-type: none"> <li>Standard (4 pieces: same phase) swing → Data: [0001] (At shipment) When Swing operation is selected, four louvers align at the horizontal discharge position and then start the Swing operation at the same time.</li> <li>Dual swing → Data: [0002] When operation is selected, the louvers of louver No. [01] and [03] move to the horizontal discharge position, the louvers of louver No. [02] and [04] move to the downward discharge position and then start the Swing operation at the same time.</li> <li>Cycle swing → Data: [0003] When operation is selected, the louver No. [01] moves to the horizontal discharge position, [03] to the downward discharge position, [02] and [04] to the middle position and then start the Swing operation at the same time.</li> </ol> <ul style="list-style-type: none"> <li>In case of selecting the Swing mode, “Dual swing” or “Cycle swing”, the following numerals is displayed at the center of the remote controller screen for approx. 3 seconds when  button was pushed to select [SWING]. (No display for the standard swing) (In the case of RBC-AMT***)</li> </ul> <div style="text-align: center;">  <p><b>Dual swing</b>                      <b>Cycle swing</b></p> </div> <p><b>&lt;&lt;Louver lock (Louver fix)&gt;&gt;</b></p> <ul style="list-style-type: none"> <li>For the air direction setup for each discharge port, the louver position can be locked during the normal operation.</li> <li>An arbitrary air direction of an arbitrary louver can be registered and set by keeping  button pushed for 4 seconds or more on the remote controller. (In the case of RBC-AMT***) Louver lock can be selected by Code No.(DN) setup [F1], [F2], [F3] or [F4]. (In the case of RBC-ASCU11-*)</li> <li>The louver lock can be set by registering the setup data to Code No.(DN) [F1] to [F4] according to the following table.</li> </ul> <table border="1" data-bbox="443 1888 1114 2056"> <thead> <tr> <th>Code No.(DN)</th> <th>Objective louver No.</th> <th>Setup data</th> </tr> </thead> <tbody> <tr> <td>F1</td> <td>01</td> <td rowspan="2">0000: Release (At shipment) 0001: Horizontal discharge position</td> </tr> <tr> <td>F2</td> <td>02</td> </tr> <tr> <td>F3</td> <td>03</td> <td style="text-align: center;">~</td> </tr> <tr> <td>F4</td> <td>04</td> <td>0005: Downward discharge position</td> </tr> </tbody> </table>	Code No.(DN)	Objective louver No.	Setup data	F1	01	0000: Release (At shipment) 0001: Horizontal discharge position	F2	02	F3	03	~	F4	04	0005: Downward discharge position	<p>Subject model : Compact 4-way</p> <p>Carry out setting operation during stop of the unit; otherwise the unit stops operation.</p> <p>Carry out setting operation during stop of the unit; otherwise the unit stops operation.</p>
Code No.(DN)	Objective louver No.	Setup data															
F1	01	0000: Release (At shipment) 0001: Horizontal discharge position															
F2	02																
F3	03	~															
F4	04	0005: Downward discharge position															

No.	Item	Outline of specifications	Remarks																		
19	Louver control (Continued)	<ul style="list-style-type: none"> <li>If there is the locked louver in the unit, [  ] goes on the remote controller screen.</li> <li>While the following controls are performed, the louvers operate even if executing the louver lock.</li> </ul> <table border="1" data-bbox="459 358 1369 611"> <thead> <tr> <th></th> <th>Control which ignores lock</th> <th>Objective louver No.</th> </tr> </thead> <tbody> <tr> <td>①</td> <td>Operation stop</td> <td>Full-close position</td> </tr> <tr> <td>②</td> <td>When heating operation started</td> <td>Horizontal discharge position</td> </tr> <tr> <td>③</td> <td>Heating thermostat OFF</td> <td>Horizontal discharge position</td> </tr> <tr> <td>④</td> <td>During defrost operation</td> <td>Horizontal discharge position</td> </tr> <tr> <td>⑤</td> <td>Initialize operation</td> <td>Full-close position</td> </tr> </tbody> </table> <ul style="list-style-type: none"> <li>The real louver corresponding to the louver No. displayed on the remote controller screen during setting of louver lock operates swinging.</li> </ul>		Control which ignores lock	Objective louver No.	①	Operation stop	Full-close position	②	When heating operation started	Horizontal discharge position	③	Heating thermostat OFF	Horizontal discharge position	④	During defrost operation	Horizontal discharge position	⑤	Initialize operation	Full-close position	<p>For the setting operation, refer to [How to set louver lock] of Installation Manual.</p> <p>It is position check operation and it does not link with the real louver and air direction setup (Illustration on the remote controller screen).</p>
	Control which ignores lock	Objective louver No.																			
①	Operation stop	Full-close position																			
②	When heating operation started	Horizontal discharge position																			
③	Heating thermostat OFF	Horizontal discharge position																			
④	During defrost operation	Horizontal discharge position																			
⑤	Initialize operation	Full-close position																			
20	DC motor	<ol style="list-style-type: none"> <li>When the fan starts, positioning is performed for the starter and the rotor. (Vibrate slightly)</li> <li>DC motor operates according to the command from the indoor controller.</li> </ol> <p><b>(Note)</b> If the fan rotates by entry of outside air, etc while the air conditioner stopped, the indoor unit may operate as the fan motor stops.</p> <p><b>(Note)</b> If the fan lock was detected, the operation of the indoor unit stops and the check code is displayed.</p>	<p>Check code [P12] Subject model : Compact 4-way 2-way cassette 1-way cassette (SH) Floor standing</p>																		
21	Power saving mode	<p>(In the case of RBC-AMT***)</p> <ol style="list-style-type: none"> <li>Push the  button on the remote controller</li> <li>The “” segment lights up on the wired remote controller display.</li> <li>The requirement capacity ratio is limited to approximately 75 %.</li> <li>If the power saving operation is enabled, the settings are retained when the operation is stopped, when the mode is changed, or when the power is reset. The power saving operation will be enabled at the next time the operation starts.</li> </ol> <ul style="list-style-type: none"> <li>The operation may differ depending on the connected outdoor unit. Refer to the Service Manual of the outdoor unit.</li> </ul>																			

## 7. COMMUNICATION TYPE, MODEL NAMES AND THE MAXIMUM NUMBER OF CONNECTABLE UNITS

7-1. This air conditioning (U series) has new communication specifications, and TU2C-Link (U series) and TCC-Link (other than U series) differ in a communication type. For the communication type and the model names such as each unit or remote controllers, refer to the following table.

Communication type	TU2C-Link (U series and future models)	TCC-Link (Other than U series)
Outdoor unit	MMY-M $\overline{\text{U}}$ P*** ↑ This letter indicates U series model.	Other than U series MMY-MAP*** MCY-MHP***
Indoor unit	MM*- $\overline{\text{U}}$ P*** ↑ This letter indicates U series model.	Other than U series MM*-AP***
Wired remote controller	RBC-A** $\overline{\text{U}}$ *** ↑ This letter indicates U series model.	Other than U series
Wireless remote controller kit & receiver unit	RBC-AX $\overline{\text{U}}$ *** ↑ This letter indicates U series model.	Other than U series
Remote sensor	TCB-TC** $\overline{\text{U}}$ *** ↑ This letter indicates U series model.	Other than U series

U series outdoor unit : SMMS-u (MMY-MUP\*\*\* )  
Other than U series outdoor unit : SMMS-i, SMMS-e etc. (MMY-MAP\*\*\* )

7-2. If TU2C-Link (U series) is combined with TCC-Link (other than U series), the wiring specifications and the maximum number of connectable indoor units during group control operation will be changed.

- (1) For wiring specifications, carry out the installation, maintenance, or repair according to the attached Installation Manual.
- (2) For a communication type combination and the max. number of connectable indoor units, refer to the following table.
  - Only when all outdoor unit, indoor unit and remote control are a U series, communication method is TU2C-LINK, and the maximum number of connectable units will be 16.

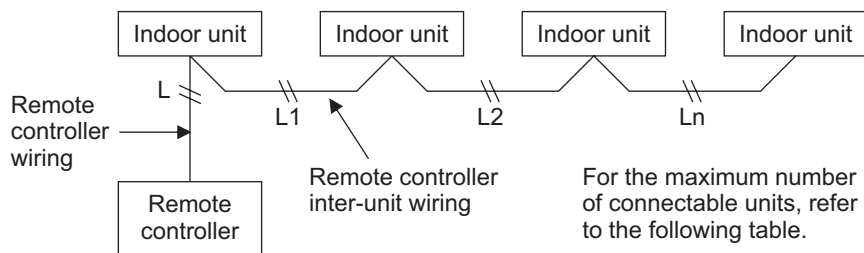

The combination of unit type and the number of the maximum connection of a communication method

	Unit type							
	U series	U series	U series	U series	*	*	*	*
Outdoor unit	U series	U series	U series	U series	*	*	*	*
Indoor unit	U series	U series	*	*	U series	U series	*	*
Remote controller	U series	*	U series	*	U series	*	U series	*
Remote sensor								
Communication type	TU2C-Link	TCC-Link						
Maximum number of connectable units	16	8						

\* Other than U series

# 8. APPLIED CONTROL AND FUNCTIONS (INCLUDING CIRCUIT CONFIGURATION)

## 8-1. Indoor controller block diagram (MCC-1643)

### 8-1-1. In case of connection of wired remote controller

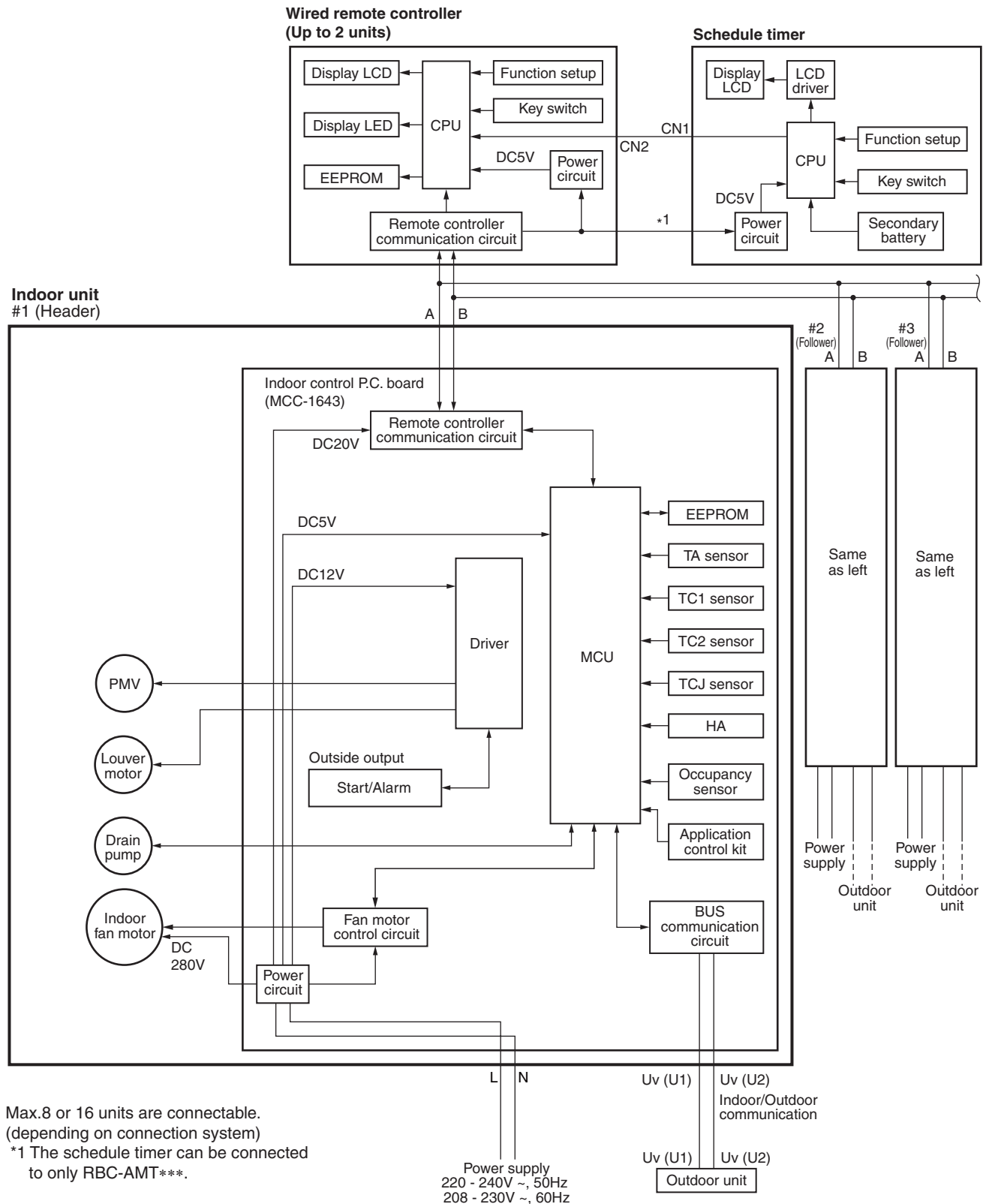

### 8-1-2. In case of connection of wireless remote controller

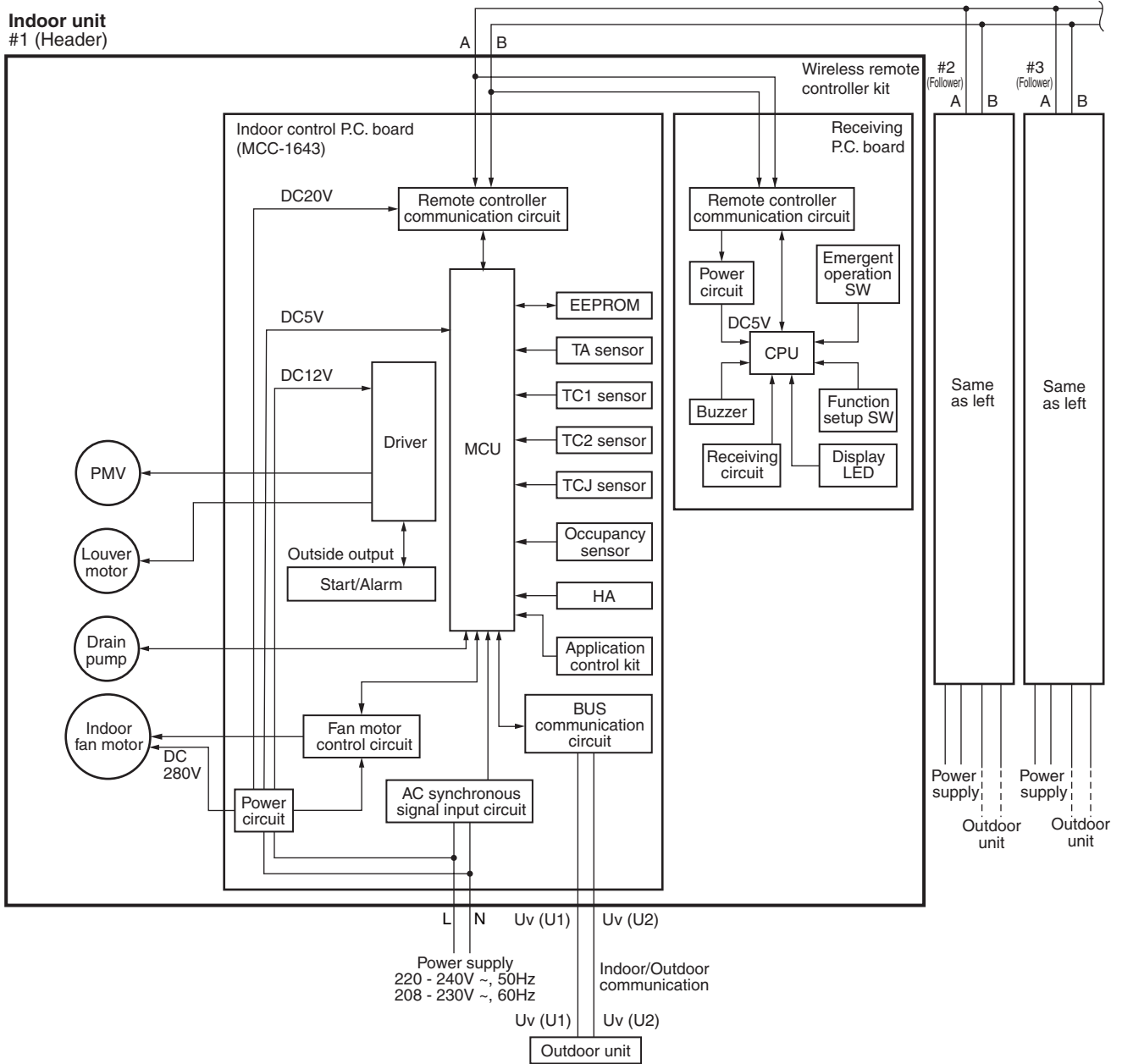



**8-1-2. In case of connection of wireless remote controller  
(Compact 4-way cassette type)**

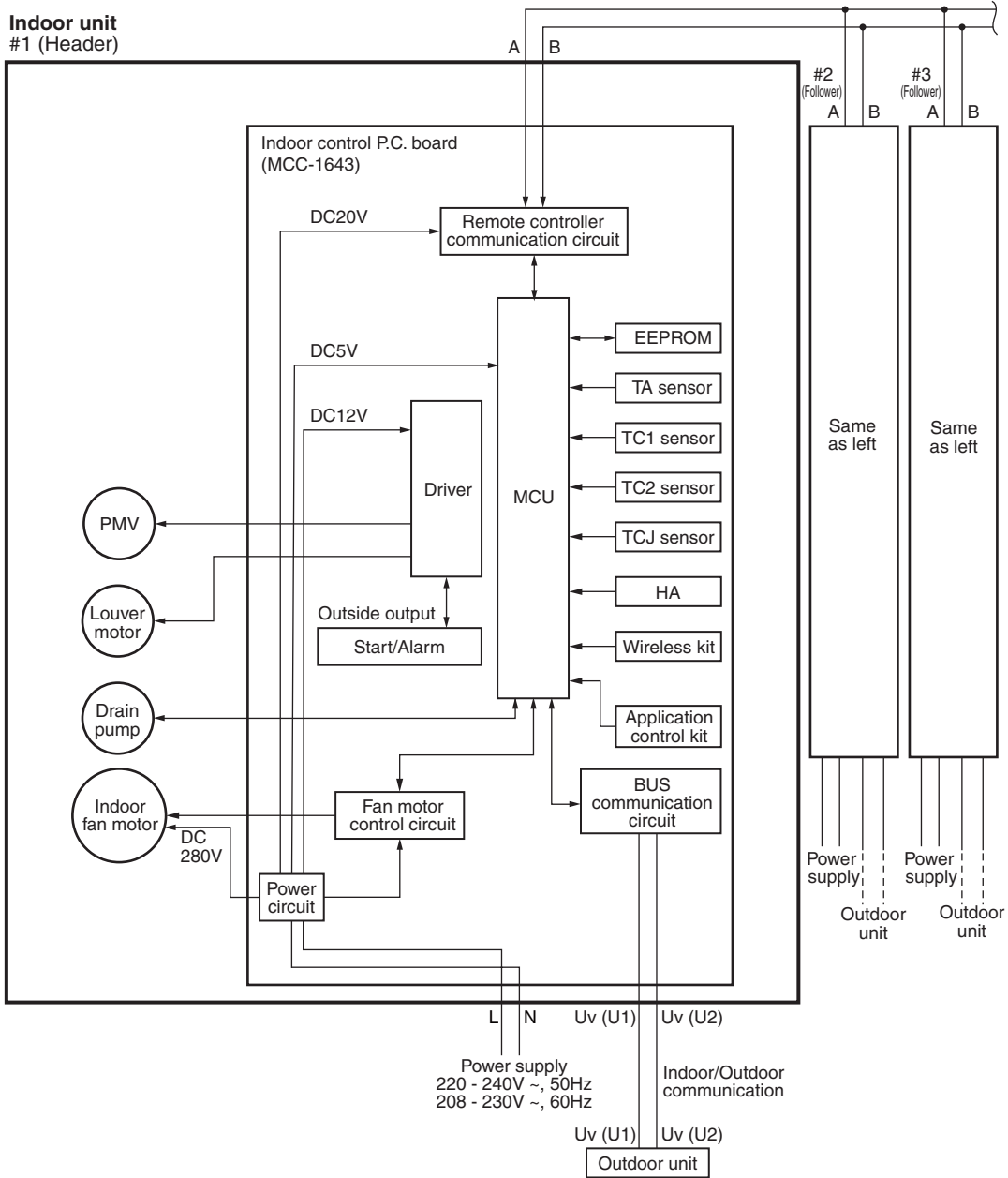

### 8-1-3. Connection of both wired remote controller and wireless remote controller

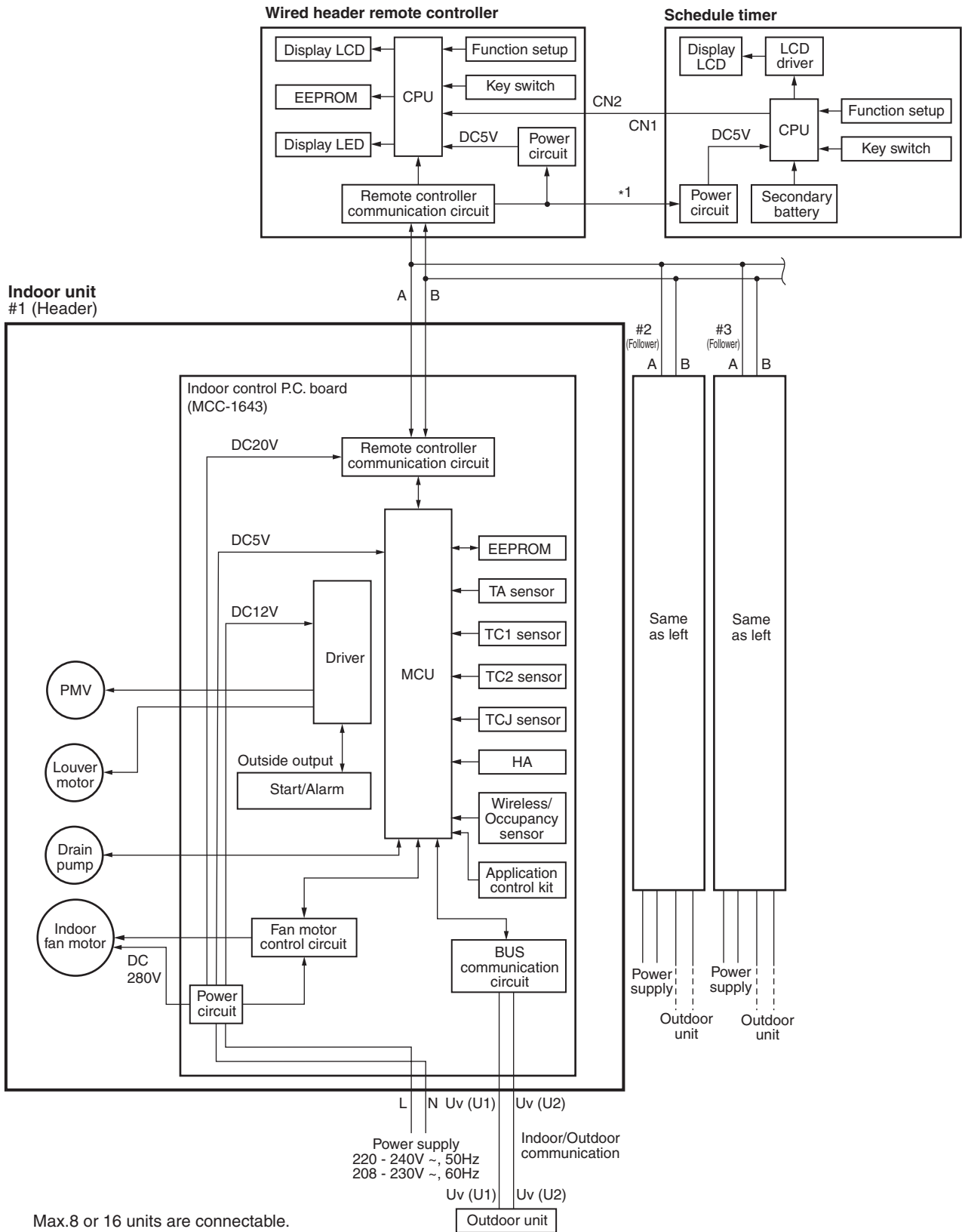

Max.8 or 16 units are connectable.  
(depending on connection system)

\*1 The schedule timer can be connected  
to only RBC-AMT\*\*\*.

## 8-2. Indoor controller block diagram (MCC-1744)

### 8-2-1. In case of connection of wired remote controller

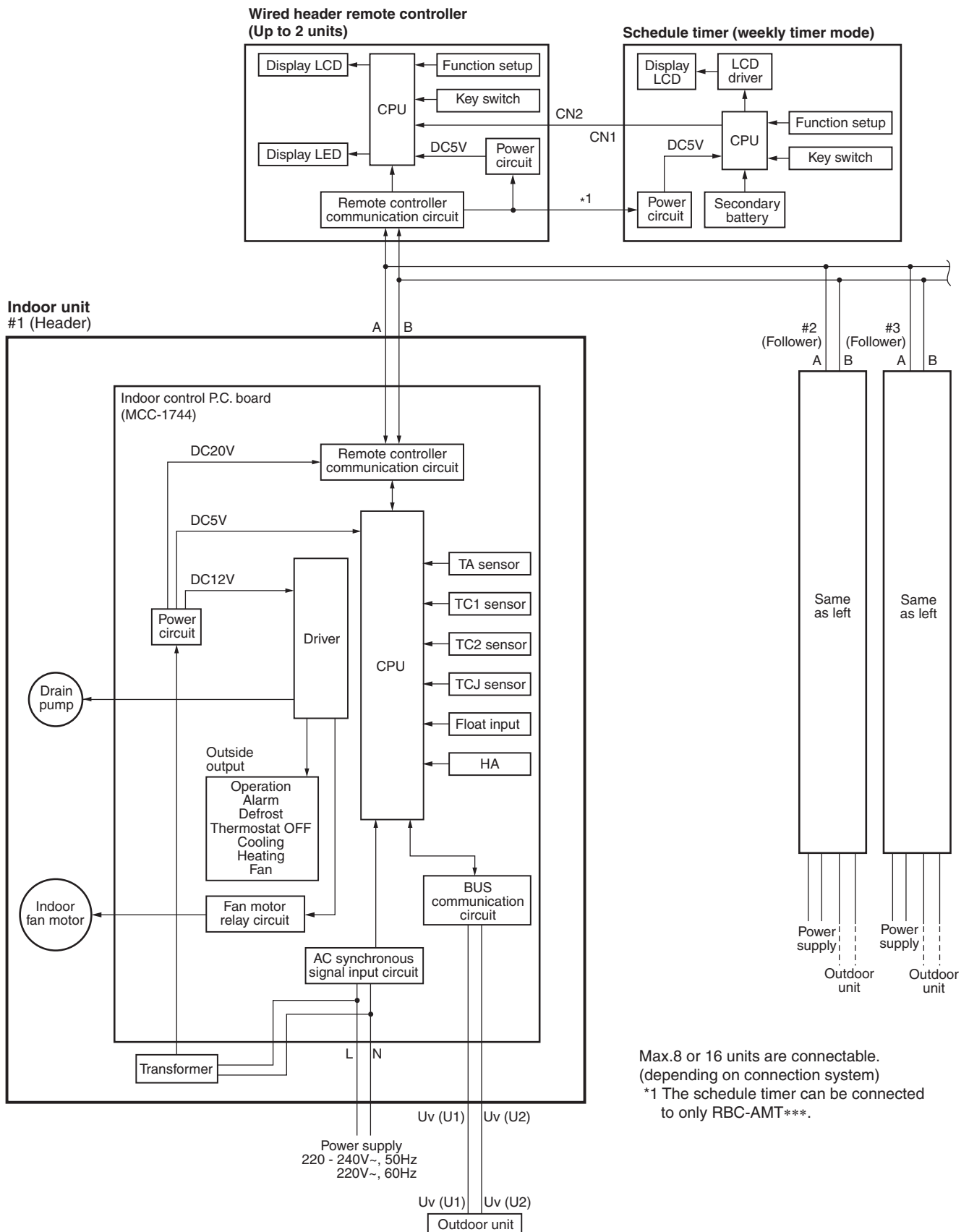

8-2-2. In case of connection of wireless remote controller

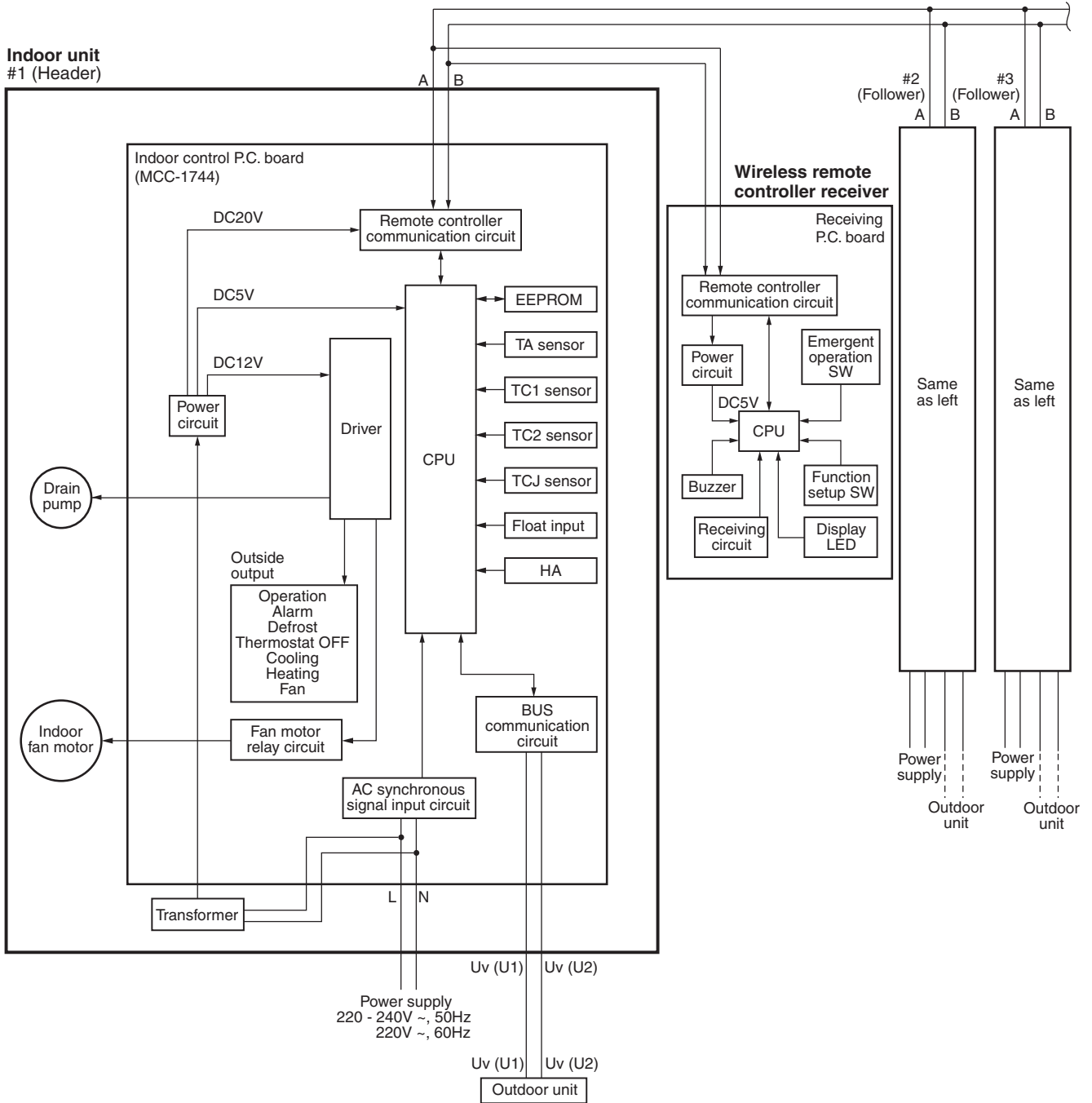

### 8-2-3. Connection of both wired remote controller and wireless remote controller

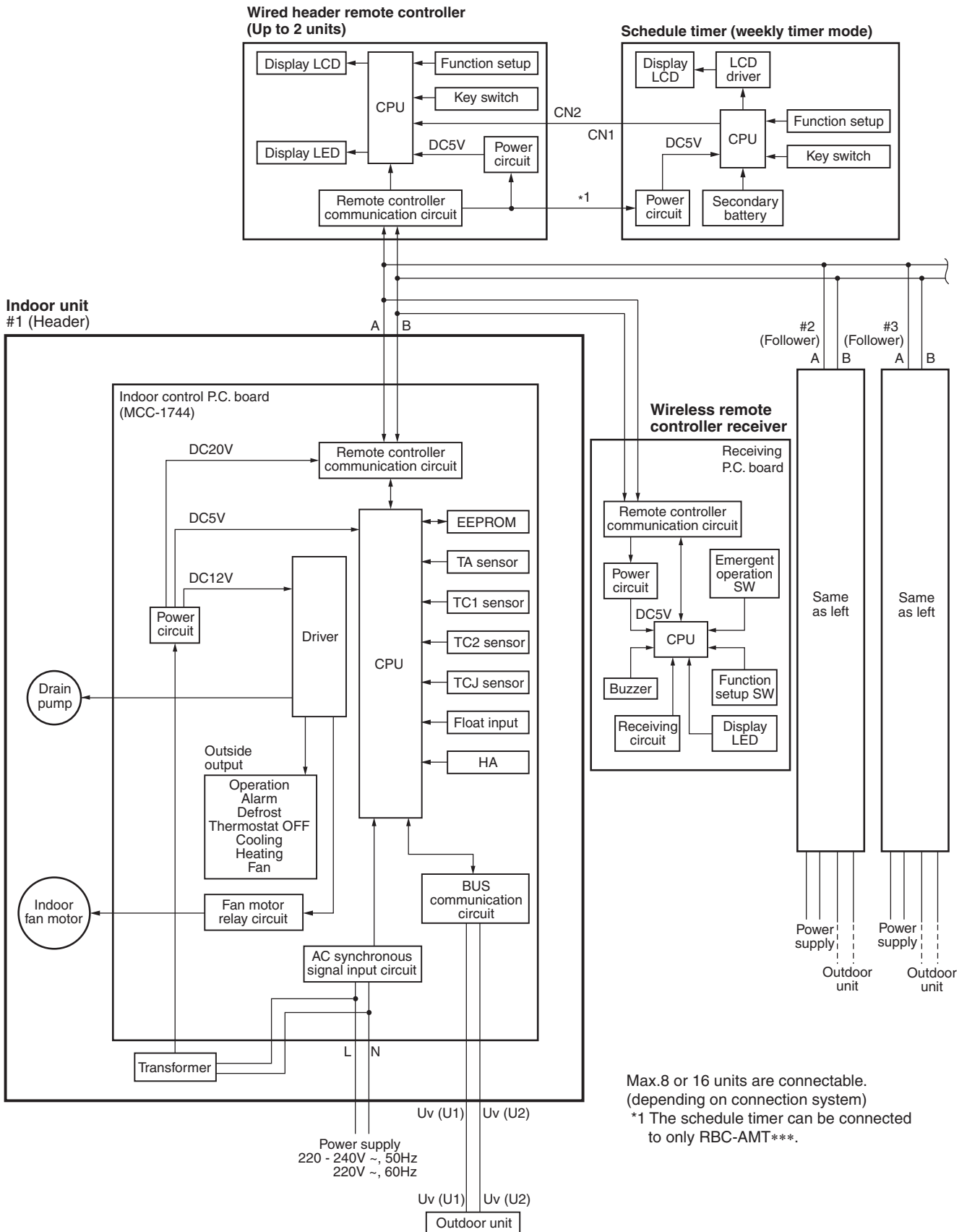

Max.8 or 16 units are connectable.  
 (depending on connection system)  
 \*1 The schedule timer can be connected to only RBC-AMT\*\*\*.

# 8-3. Indoor Print Circuit Board

## 8-3-1. MCC-1643

- Compact 4-way cassette type
- 2-way cassette type
- 1-way cassette type (SH)
- Floor standing type

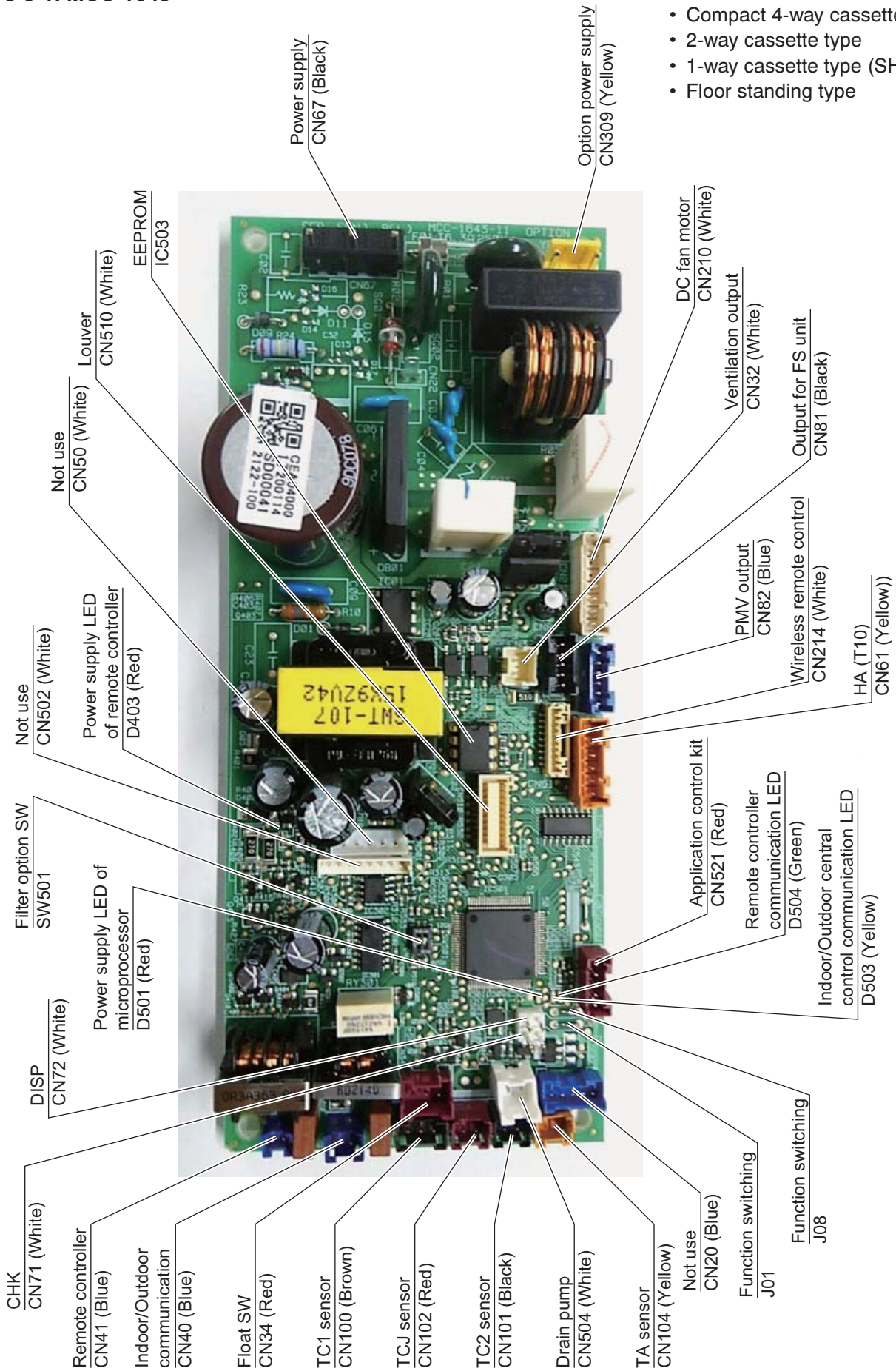

### Optional connector specifications of indoor P.C. board (MCC-1643)

Connector No.	Color	Function	Compact 4-way Cassette	2-way Cassette	1-way Cassette (SH)	Floor standing	Pin No.	Specifications	Remarks
CN32	White	Ventilation output	○	○	○	○	① ②	DC12V Output (Open collector)	Setting at shipment: Interlock of ON by indoor unit operation, with OFF by stop operation * The single operation setting by FAN button on the remote controller is performed on the remote controller (DN=31).
CN34	Red	Input for float SW	●	●	●	X (With short-circuit connector)	① ②	DC12V NC	Normal when between ①-③ short-circuits, but abnormal when open-circuits. (check code "P10" appears)
CN61	Yellow	HA	○	○	○	○	① ② ③ ④ ⑤ ⑥	Float SW input ON/OFF input 0V (COM) Remote controller prohibited input Operation output (Open collector) DC12V (COM) Warning output (Open collector)	HA ON/OFF input (J01: YES/NO=Pulse (At shipment from factory) /Static input selection) Permission/Prohibition of remote controller operation stop is performed by input. Operation ON (Answer back of HA) Warning output ON
CN71	White	CHK Operation check	○	○	○	○	① ②	Check mode input 0V	This check is used to check indoor operation. (Performs operation of indoor fan "H", Louver horizontal and Drain pump ON without communication with outdoor and remote controller)
CN72	White	DISP Exhibition mode	○	○	○	○	① ②	DISP mode input 0V	Communication is available by indoor unit and remote controller only (When the power is turned on). Shortening time of timer (Always)
CN81	Black	Output for Flow selector unit	△	△	△	△	① ② ③ ④ ⑤	DC12V EP valve output (Open collector) Balance valve output (Open collector) Suction valve output (Open collector) Discharge valve output (Open collector)	
CN309	Yellow	Output power supply for option	○	○	○	○	① ③	AC230V AC230V	This can be used as power supply for option devices.
CN521	Red	Connection for option P.C.board	△	△	△	△	① ② ③ ④ ⑤	DC12V DC5V Send Receive 0V	Connected Application control kit (TCB-PCUC2E)

● : Use in standard, ○ : Available, △ : Use by connecting parts sold separately, x : Unavailable

\* To use the functions operated by CN60, CN80, CN70 and CN73, which are provided for other P.C.board, use the Application control kit (TCB-PCUC2E) sold separately.



8-3-2. MCC-1744

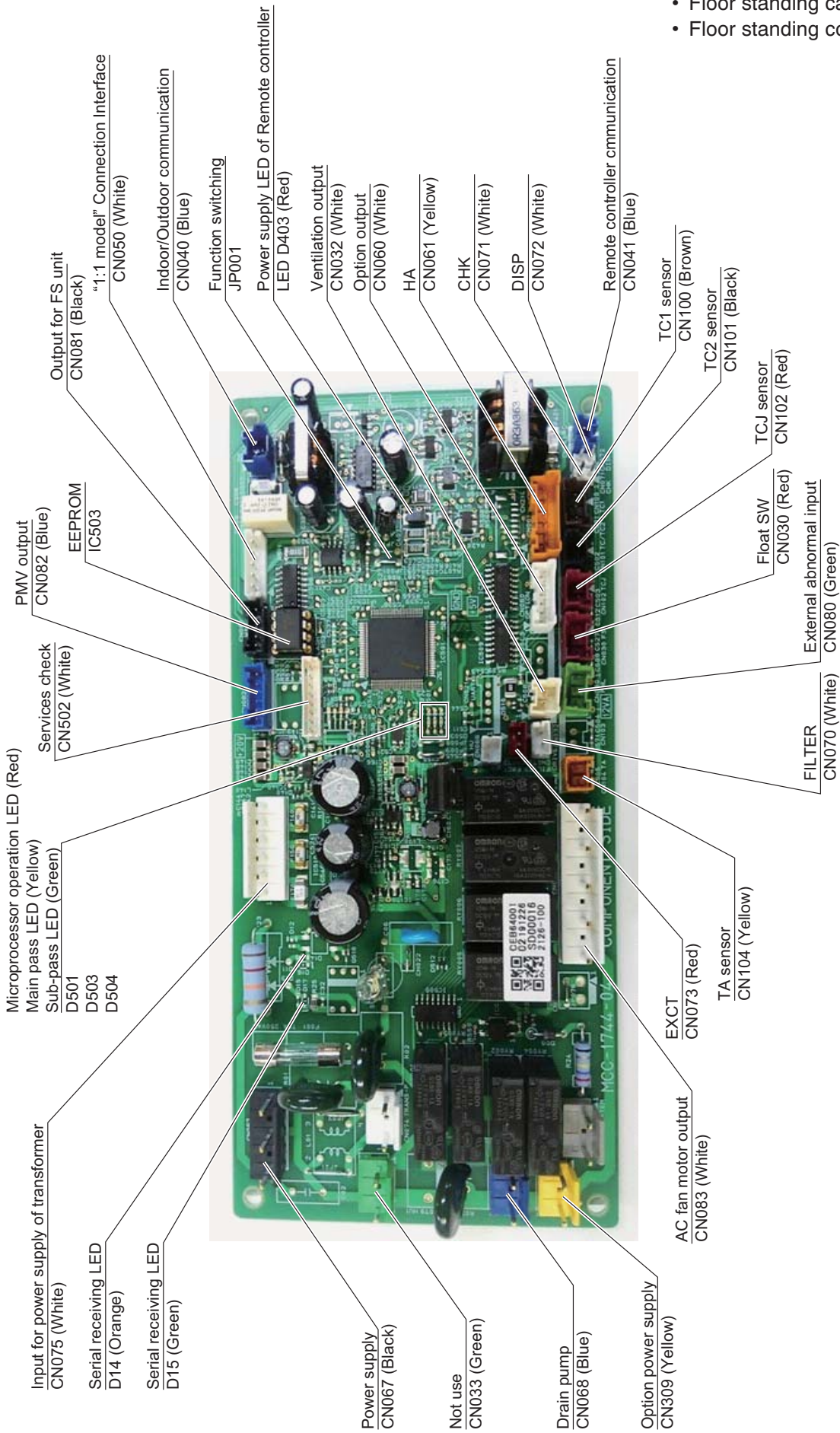

- Floor standing cabinet type
- Floor standing concealed type



### Optional connector specifications of indoor P.C. board (MCC-1744)

Connector No.	Color	Function	Floor standing concealed	Floor standing cabinet	Pin No.	Specifications	Remarks
CN032	White	Ventilation output	○	○	① ②	DC12V (COM) Output (Open collector)	Setting at shipment: Interlock of ON by indoor unit operation, with OFF by stop operation * The single operation setting by FAN button on the remote controller is performed on the remote controller (DN=31).
CN033	White	Louver output	×	×	① ③	AC230V AC230V	Output is AC200V when louver is ON.
CN034	Red	Input for float SW	×	×	① ② ③	DC12V NC Float SW input	Normal when between ①-③ short-circuits, but abnormal when open-circuits. (check code "P10" appears)
CN060	White	Option output	○	○	① ② ③ ④ ⑤ ⑥	DC12V (COM) Defrost output (Open collector) Thermostat-off output (Open collector) Cooling output (Open collector) Heating output (Open collector) Fan output (Open collector)	ON when outdoor unit is on defrost operation. ON when actual thermostat is ON (Comp. ON). ON when the operation mode is on cooling system (Cool, Dry, Auto (Cooling)). ON when the operation mode is on heating system (Heat, Auto (Heating)). ON when the indoor fan is on. (When an air cleaner is used) OFF when the clean operation is on.
CN061	Yellow	HA	○	○	① ② ③ ④ ⑤ ⑥	ON/OFF input 0V (COM) Remote controller prohibited input Operation output (Open collector) DC12V (COM) Warning output (Open collector)	HA ON/OFF input (J01: YES/NO=Pulse (At shipment from factory)/Static input selection) Permission/Prohibition of remote controller operation stop is performed by input. Operation ON (Answer back of HA) Warning output (Open collector)
CN068	Blue	Drain pump output	×	×	① ③	AC230V AC230V	Output is AC200V in cooling and float SW operation.
CN070	White	Filter	○	○	① ②	Input 0V	Option abnormal input (Display of protective operation for equipment installed to the outside) * Perform the settings having option abnormal input from the remote controller. (DN [2A] = 0002 → 0001).
CN071	White	CHK Operation check	○	○	① ②	Check mode input 0V	Use for operation check of indoor unit. (Performs operation of indoor fan "H" Louver horizontal and Drain pump ON without communication with outdoor and remote controller)
CN072	White	DISP Exhibition mode	○	○	① ②	DISP mode input 0V	Communication is available by indoor unit and remote controller only (When the power is turned on). Shortening time of timer (Always)
CN073	Red	EXCT demand	○	○	① ②	Demand input 0V	Forced thermostat OFF operation for indoor unit
CN080	Green	External abnormal input	○	○	① ② ③	DC12V NC External abnormal input	Make the check code of "L30" occur (by continuing operation for one min) and perform the forced stop.
CN081	Black	Output for Flow selector unit	△	△	① ② ③ ④ ⑤	DC12V EP valve output (Open collector) Balance valve output (Open collector) Suction valve output (Open collector) Discharge valve output (Open collector)	
CN309	Yellow	Output power supply for option	○	○	① ③	AC230V AC230V	This can be used as power supply for option devices.

● : Use in standard, ○ : Available, △ : Use by connecting parts sold separately, × : Unavailable

## 8-4. Test run of indoor unit

### ■ Cooling/Heating test run check

The test run for cooling/heating can be performed from either indoor remote controller or outdoor interface P.C. board. Refer to the Installation Manual and Service Manual of outdoor unit for the procedure of the test run from an outdoor interface P.C. board.

#### ◆ In case of wired remote controller

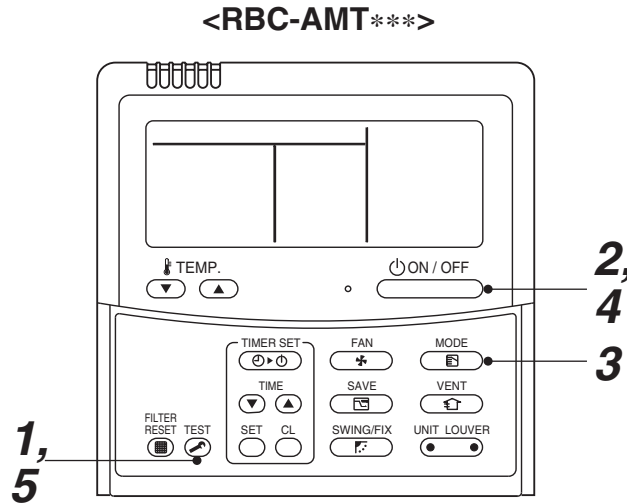

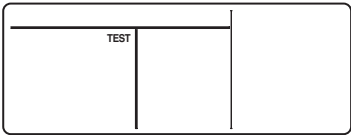
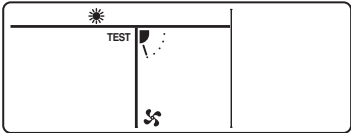
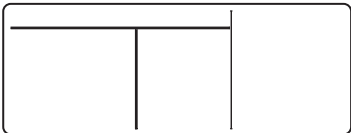
Procedure	Operation contents
<b>1</b>	<p>Push [TEST] button for 4 seconds or more. [TEST] is displayed at the display part and the mode enters in TEST mode.</p> 
<b>2</b>	<p>Push [ON/OFF] button.</p>
<b>3</b>	<p>Change the mode from [COOL] to [HEAT] using [MODE] button.</p> <ul style="list-style-type: none"> <li>• Do not use [MODE] button for other mode except [COOL]/[HEAT] modes.</li> <li>• The temperature cannot be adjusted during test run.</li> <li>• The trouble detection is performed as usual.</li> </ul> 
<b>4</b>	<p>After test run, push [ON/OFF] button to stop the operation. (Display on the display part is same to that in Procedure <b>1</b>.)</p>
<b>5</b>	<p>Push [TEST] button to clear the TEST mode. ([TEST] display in the display part disappears and status becomes the normal stop status.)</p> 

**Note)** The test run returns to the normal operation after 60 minutes.

<RBC-ASCU11-\*>

**Be sure to stop the air conditioner before making settings.**

(Change the setup while the air conditioner is not working.)

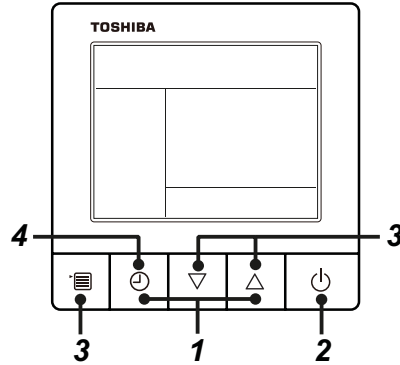

- 1** Push and hold OFF timer button and [  $\Delta$  ] setting button simultaneously for 10 seconds or more. [TEST] is displayed on the display part and the test run is permitted.

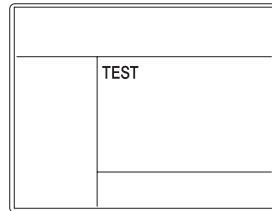

- 2** Push ON/OFF button.

- 3** Push menu button to select the operation mode. Select [  $\odot$  Cool] or [  $\odot$  Heat] with [  $\nabla$  ] [  $\Delta$  ] setting button.

- Do not run the air conditioner in a mode other than [Cool] or [Heat].
- The temperature setting function does not work during test run.
- The check code is displayed as usual.

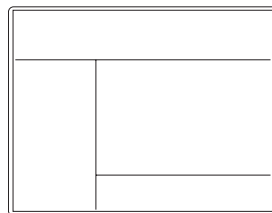

- 4** After the test run, push OFF timer button to stop a test run.

([TEST] disappears on the display and the air conditioner enters the normal stop mode.)



**◆ In case of wireless remote controller**

**1** Turn on the power of the air conditioner.  
 When power is turned on for the first time after installation, it takes approx. 5 minutes until the remote controller becomes available. In the case of subsequent power-on, it takes approx. 1 minute until the remote controller becomes available.  
 Execute a test run after the predetermined time has passed.

**2** Push “ON/OFF” button on the remote controller, select [  Cool ] or [  Heat ] with “MODE” button, and then select [  HIGH ] with “FAN” button.

**3**

Cooling test run	Heating test run
Set the temperature to 17 °C with the temp. setup buttons.	Set the temperature to 30 °C with the temp. setup buttons.

**4**

Cooling test run	Heating test run
After confirming a signal receiving sound “beep” immediately set the temperature to 18 °C with the temp. setup buttons.	After confirming a signal receiving sound “beep” immediately set the temperature to 29 °C with the temp. setup buttons.

**5**

Cooling test run	Heating test run
After confirming a signal receiving sound “beep” immediately set the temperature to 17 °C with the temp. setup buttons.	After confirming a signal receiving sound “beep” immediately set the temperature to 30 °C with the temp. setup buttons.

**6** Repeat procedures **4 → 5 → 4 → 5**.  
 Indicators “Operation” (green), “Timer” (green), and “Ready” (orange) in the wireless receiver section flash in approx. 10 seconds, and the air conditioner starts operation. If any of these indicators does not flash, repeat procedures 2 to 5.

**7** Upon completion of the test run, push “ON/OFF” button to stop operation.

<Overview of test run operations using the wireless remote controller>

▼ Cooling test run:  
 ON/OFF → 17 °C → 18 °C → 17 °C → 18 °C → 17 °C → 18 °C → 17 °C → (test run) → ON/OFF

▼ Heating test run:  
 ON/OFF → 30 °C → 29 °C → 30 °C → 29 °C → 30 °C → 29 °C → 30 °C → (test run) → ON/OFF

## ■ Check function for operation of indoor unit (Functions at indoor unit side)

This function is provided to check the operation of the indoor unit individually without connecting to the remote controller or the outdoor unit. This function can be used regardless of the ON/OFF operation.

However, it is recommend to avoid using this function for along time, otherwise the trouble of the equipment may occurred.

### [How to operate]

- 1) Short-circuit CHK pin (CN71 on the indoor P.C. board).  
 The operation mode may differ according to the indoor unit status at that time.  
 Normal time: Both float SW and fan motor are normal.  
 Abnormal time: Either one of float SW or fan motor is abnormal.
- 2) During the normal time, the minimum opening degree (30pls) of the indoor PMV can be set only when both CHK pin (CN71) and DISP pin (CN72) on the indoor P.C board are short-circuited. If the short-circuit at DISP pin (CN72) is opened, the indoor PMV will be at the maximum opening degree (1500pls). When open DISP pin, the maximum opening degree (1500 pls) can be obtained again.
  - For the detailed positions of CHK pin (CN71 on indoor P.C. board) and DISP pin (CN72 on indoor P.C. board), refer to the indoor P.C. board.

### [How to clear]

Open CHK pin. If the system is on operation, it will temporarily stop then automatically restart after a while.

	Short-circuit of CHK pin		
	Normal time		Abnormal time
	DISP pin open	DISP pin short circuit	
Fan motor	(H)	(H)	Stop
Indoor PMV (*)	Max. opening degree (1500 pls)	Min. opening degree (30 pls)	Min. opening degree (30 pls)
Louver	Vertical	Vertical	Immediate stop
Communication	All ignored	All ignored	All ignored
P.C. board LED	Lights	Lights	Flashes

\* The actual indoor PMV opening degree may differ from the described values due to adjustment depending on PMV types.

- To exchange the indoor PMV coil, set the indoor PMV to Max. opening degree.

## 8-5. Method to set indoor unit function DN code

(When performing this task, be sure to use a wired remote controller.)

### ◆ Procedure

Be sure to stop the air conditioner before making settings

<RBC-AMT\*\*\*>

- 1** Push the + + buttons simultaneously and hold for at least 4 seconds.  
The unit No. displayed first is the address of the header indoor unit in group control.  
Then the fan and louver of the selected indoor unit move.
- 2** Each time the button (left side of the button) is pressed, one of the indoor unit Nos. under group control is displayed in turn. Then the fan and louver of the selected indoor unit move.
- 3** Use the button to select the CODE No. (DN code) of the desired function.
- 4** Use the button to select the desired SET DATA associated with the selected function.
- 5** Push the button. (The display changes from flashing to steady.)
  - To change the selected indoor unit, go back to step 2.
  - To change the selected function, go back to step 3.
- 6** When the button is pushed, the system returns to normal off state.

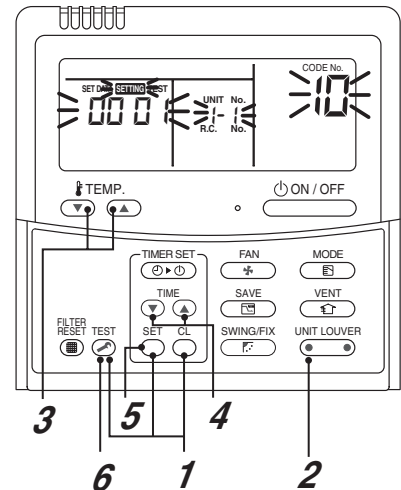

<RBC-ASCU11-\*>

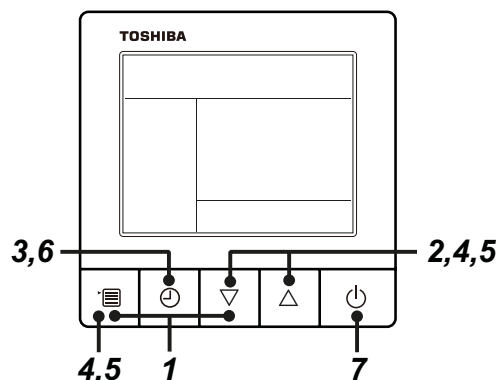

- 1** Push and hold menu button and [ ] setting button simultaneously for 10 seconds or more.
  - After a while, the display flashes as shown in the figure. "ALL" is displayed as indoor unit numbers during initial communication immediately after the power has been turned on.

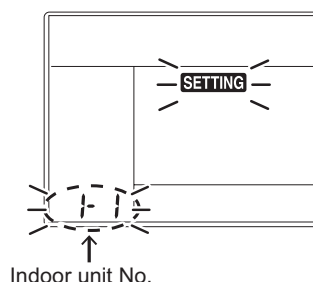

- 2** Each time [ ] [ ] setting button is pushed, indoor unit numbers in the group control change cyclically. Select the indoor unit to change settings for.
  - The fan of the selected indoor unit runs. The indoor unit can be confirmed for which to change settings.

**3 Push OFF timer button to confirm the selected indoor unit.**

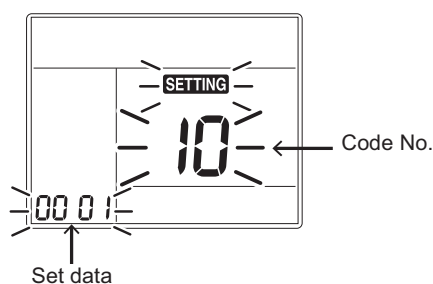

**4 Push the menu button to make Code No. [ \*\* ] flash. Change Code No. [ \*\* ] with [ ∇ ] [ △ ] setting button.**

**5 Push the menu button to make Set data [ \*\*\*\* ] flash. Change Set data [ \*\*\*\* ] with [ ∇ ] [ △ ] setting button.**

**6 Push OFF timer button to complete the set up.**

- To change other settings of the selected indoor unit, repeat from Procedure **4**.

**7 When all the settings have been completed, push ON/OFF button to finish the settings. (Return to the normal mode)**

“ **SETTING** ” flashes and then the display content disappears and the air conditioner enters the normal stop mode. (The remote controller is unavailable while “ **SETTING** ” is flashing.)

- To change settings of another indoor unit, repeat from Procedure **1**.

## Indoor unit function Code No. (DN Code) table

(includes functions needed to perform applied control on site)

DN	Item	Description	At shipment
01	Filter display delay timer	0000: None 0001: 150H 0002: 2500H 0003: 5000H 0004: 10000H	Depending on model type
02	Dirty state of filter	0000: Standard 0001: High degree of dirt (Half of standard time)	0000: Standard
03	Central control address	0001: No.1 unit to 0064: No.64 unit ... TCC-LINK 0001: No.1 unit to 0128: No.128 unit ... TU2C-LINK 00Un: Unfixed (When using U series remote controller) 0099: Unfixed (Other than U series remote controller)	00Un/0099: Unfixed *1
04	Specific indoor unit priority	0000: No priority 0001: Priority	0000: No priority
06	Heating temp. shift	0000: 0 °C 0001: +1 °C 0002: +2 °C to 0010: +10 °C (Up to +6 recommended)	Depending on model type
0b	Demand control (CN73 / CN4)	0000: Demand input 0001: O2 sensor input 0002: Card input setup.3 0003: Fire alarm input (Normal open) 0004: Card input setup.4 0005: Fire alarm input (Normal close) 0006: Notice code (202) 0007: Card input setup.5 0008: Card input setup.1 0009: Card input setup.2	0000: Demand input
0d	Existence of [AUTO] mode	0000: Provided 0001: Not provided (Automatic selection from connected outdoor unit)	0001: Not provided
0F	Cooling only	0000: Heat pump 0001: Cooling only (No display of [AUTO] [HEAT])	0000: Heat pump
10	Type	Refer to <b>Type DN code "10" list</b>	Depending on model type
11	Indoor unit capacity	0000: Unfixed 0001 to 0044 Refer to Indoor Unit Capacity DN code "11" list	According to capacity type
12	Line address	0001: No.1 unit to 0064: No.30 unit ... TCC-LINK 0001: No.1 unit to 0128: No.128 unit ... TU2C-LINK 00Un: Unfixed (When using U series remote controller) 0099: Unfixed (Other than U series remote controller)	00Un/0099: Unfixed *1
13	Indoor unit address	0001: No.1 unit to 0064: No.64 unit ... TCC-LINK 0001: No.1 unit to 0128: No.128 unit ... TU2C-LINK 00Un: Unfixed (When using U series remote controller) 0099: Unfixed (Other than U series remote controller)	00Un/0099: Unfixed *1
14	Group address	0000: Individual 0001: Header unit of group 0002: Follower unit of group 00Un: Unfixed (When using U series remote controller) 0099: Unfixed (Other than U series remote controller)	00Un/0099: Unfixed *1
19	Louver type (Air direction adjustment)	0000: No louver 0001: Swing only 0004: (4-way Air Discharge Cassette type, etc.)	Depending on model type
1E	Temp difference of [AUTO] mode selection COOL → HEAT, HEAT → COOL	0000: 0 °C to 0010: 10 °C (Ts ± 5°C) Ts:Remote controller setup temp.	0003: 3 °C (Ts ±1.5 °C )
28	Automatic restart of power failure	0000: None 0001: Restart	0000: None
2A	Selection of option/Trouble input (TCB-PCUC2E: CN3)	0000: Filter input 0001: Alarm input 0002: None (Air washer, etc.)	0002: None
2E	HA terminal (CN61) select	0000: Usual 0001: Card input setup.1 (3) 0002: Fire alarm input (Normal open) 0003: Card input setup.2 (4) 0004: Notice code (201) 0005: Card input setup.5	0000: Usual (HA terminal)
31	Ventilating fan control	0000: Unavailable 0001: Available	0000: Unavailable
32	TA sensor selection	0000: Indoor unit TA sensor 0001: Remote controller sensor	0000: Indoor unit TA sensor



DN	Item	Description	At shipment
<b>33</b>	Temperature unit select	0000: °C 0001: °F	0000: °C
<b>5d</b>	External static pressure High-ceiling adjustment (Air flow selection)	Refer to next page.	Depending on model type
<b>60</b>	Timer setting (wired remote controller)	0000: Available (can be performed) 0001: Unavailable (cannot be performed)	0000: Available
<b>77</b>	Dual set point	0000: Unavailable 0002: Available	0000: Unavailable
<b>79</b>	Alarm output setup of the header unit	0000: Not including the state of following unit 0001: Including the state of following unit	0000: Not including the state of following unit
<b>b3</b>	Soft cooling	0000: Unavailable 0001: Available	0001: Available
<b>b5</b>	Occupancy sensor/ Wireless Remote controller Provided / None	0000: None 0001: Occupancy sensor provided 0002: Wireless remote controller provided	0000: None
<b>b6</b>	Occupancy sensor Enable / Invalid (Absence time judgment time)	0000: Invalid 0001: 30min. 0002: 60min. 0003: 120min. 0004: 150min.	0002: Enable (60 min.)
<b>b7</b>	Occupancy sensor operation at absent time	0000: Stand by 0001: operation stop	0000: Stand by
<b>CF</b>	4-way cassette type model name	0000: Standard Model 0001: Smart cassette	Depending on model type
<b>d0</b>	Whether the power saving mode can be set by the remote controller	0000: Invalid 0001: Valid	0001: Valid
<b>E0</b>	Destination	0000: Japan 0004: Global	0004: Global
<b>E6</b>	Wireless remote controller A-B selection	0000: A 0001: B	0000: A
<b>F0</b>	Swing mode	0000 : Out of sync swing 0001 : 4-way sync swing 0002 : Dual swing 0003 : Cycle swing	0000: Not including 4-way 0001: 4-way (Compact)
<b>F1</b>	Louver fixed position (Louver No.1)	0000 : Release 0001 : Horizontal discharge position 0005 : Downward discharge position	0000: Not fixed
<b>F2</b>	Louver fixed position (Louver No.2)	0000 : Release 0001 : Horizontal discharge position 0005 : Downward discharge position	0000: Not fixed
<b>F3</b>	Louver fixed position (Louver No.3)	0000 : Release 0001 : Horizontal discharge position 0005 : Downward discharge position	0000: Not fixed
<b>F4</b>	Louver fixed position (Louver No.4)	0000 : Release 0001 : Horizontal discharge position 0005 : Downward discharge position	0000: Not fixed
<b>F6</b>	Presence of Application control kit (TCB-PCUC2E)	0000: None 0001: Exist	0000: None
<b>FC</b>	Communication protocol *2	0000: TCC-LINK 0003: TU2C-LINK	0000: TCC-LINK
<b>Fd</b>	Priority operation mode (FS unit)	0000: Heating 0001: Cooling	0000: Heating
<b>FE</b>	FS unit address	0001: No.1 unit to 0064: No.64 unit ... TCC-LINK 0001: No.1 unit to 0128: No.128 unit ... TU2C-LINK 00Un: Unfixed (When using U series remote controller) 0099: Unfixed (Other than U series remote controller)	00Un/0099: Unfixed *1

DN	Item	Description	At shipment
180	Notice code number 01	0000: None 0001 ~ 0255 : Notice code 0129 : Notice code (201) 0130 : Notice code (202) (0001 ~ 0255 : TU2C-LINK only)	0000: None
181	Notice code number 02		0000: None
182	Notice code number 03		0000: None
183	Notice code number 04		0000: None
184	Notice code number 05		0000: None
185	Notice code number 06		0000: None
186	Notice code number 07		0000: None
187	Notice code number 08		0000: None
188	Notice code number 09		0000: None
189	Notice code number 10		0000: None
103	Remote controller	0000: Use                      0001: Do not use	0000 : Use
1FB	Central device control state	0000: No central device control (Remote controller use is possible) 0001: Central device control (Remote controller use is impossible)	0000: No central device control
1FC	Indoor Unit terminating resistance	0000: OFF                      0001: ON	0000: OFF

\*1 Display order of "00Un" and "0099" varies depending on remote controller models or communication types.

For Central control address (DN [03]), Indoor unit address (DN [13]), FS unit address (DN [FE])

Remote controller	Communication type	Display order
U series	TU2C-LINK	... ⇔ 0128 ⇔ 00Un ⇔ 0001 ⇔ ...
	TCC-LINK	... ⇔ 0064 ⇔ 00Un ⇔ 0001 ⇔ ...
Other than U series	TCC-LINK	... ⇔ 0064 ⇔ 0099 ⇔ 0001 ⇔ ...

For Line address (DN [12])

Remote controller	Communication type	Display order
U series	TU2C-LINK	... ⇔ 0128 ⇔ 00Un ⇔ 0001 ⇔ ...
	TCC-LINK	... ⇔ 0030 ⇔ 00Un ⇔ 0001 ⇔ ...
Other than U series	TCC-LINK	... ⇔ 0030 ⇔ 0099 ⇔ 0001 ⇔ ...

For Group address (DN [14])

Remote controller	Communication type	Display order
U series	TU2C-LINK	... ⇔ 0002 ⇔ 00Un ⇔ 0000 ⇔ ...
	TCC-LINK	
Other than U series	TCC-LINK	... ⇔ 0002 ⇔ 0099 ⇔ 0000 ⇔ ...

\*2 Communication protocol can be automatically switched with the setup in the outdoor unit during installation.

## [5d] External static pressure & High-ceiling adjustment

### <2-way Cassette, 1-way Cassette SH Type>

Set data	High-ceiling adjustment
0000	Standard (Factory default)
0001	High ceiling 1
0003	High ceiling 3

### <Compact 4-way Cassette>

Set data	High-ceiling adjustment
0000	Standard (Factory default)
0001	High ceiling 1 (UP015 only)
0003	High ceiling 3 (UP015 only)

### Type

#### DN code "10"

Value	Type	Model
0000	1-way cassette	MMU-UP***SH*
0002	2-way cassette	MMU-UP***WH*
0010	Floor standing cabinet	MML-UP***H*
0011	Floor standing concealed	MML-UP***BH*
0013	Floor standing type	MMF-UP***H*
0014	Compact 4-way cassette	MMU-UP***MH*

### Indoor Unit Capacity

#### DN code "11"

##### ■ 2-way cassette type

Value	Capacity
0000*	Invalid
0001	007 type
0003	009 type
0005	012 type
0007	015 type
0009	018 type
0011	024 type
0012	027 type
0013	030 type
0015	036 type
0017	048 type
0018	056 type

##### ■ Floor standing cabinet type

Value	Capacity
0000*	Invalid
0001	007 type
0003	009 type
0005	012 type
0007	015 type
0009	018 type
0011	024 type

##### ■ 1-way cassette type

Value	Capacity
0000*	Invalid
0007	015 type
0009	018 type
0011	024 type

##### ■ Floor standing concealed type

Value	Capacity
0000*	Invalid
0001	007 type
0003	009 type
0005	012 type
0007	015 type
0009	018 type
0011	024 type

##### ■ Compact 4-way cassette type

Value	Capacity
0000*	Invalid
0041	005 type
0001	007 type
0003	009 type
0005	012 type
0007	015 type
0009	018 type

##### ■ Floor standing type

Value	Capacity
0000*	Invalid
0007	015 type
0009	018 type
0011	024 type
0012	027 type
0015	036 type
0017	048 type
0018	056 type

\* "0000" is default value stored in EEPROM mounted on service P.C. board

## 8-6. Applied control of indoor unit

### ■ Control system using Remote location ON/OFF control box (TCB-IFCB-4E2)

#### Wiring and setting

- In the case of group control, the control system functions as long as it is connected to one of the indoor units (control P.C. board) in the group. If it is desired to access the operation and trouble statuses of other units, relevant signals must be brought to it from those units individually.

#### 1. Control items

- |                               |   |
|-------------------------------|---|
| (1) Start / Stop input signal | Start / stop of unit  |
| (2) In-operation signal       | Output present while unit in normal operation   |
| (3) Check code Output         | present while alarm (e.g. serial communication trouble or operation of protective device for indoor / outdoor unit) being activated |

#### 2. Wiring diagram of control system using Remote location ON/OFF control box (TCB-IFCB-4E2)

- Input IFCB-4E2: No-voltage ON / OFF serial signal
- Output No-voltage contact (in-operation and check code indication)  
Contact capacity: Max. AC 240 V, 0.5 A

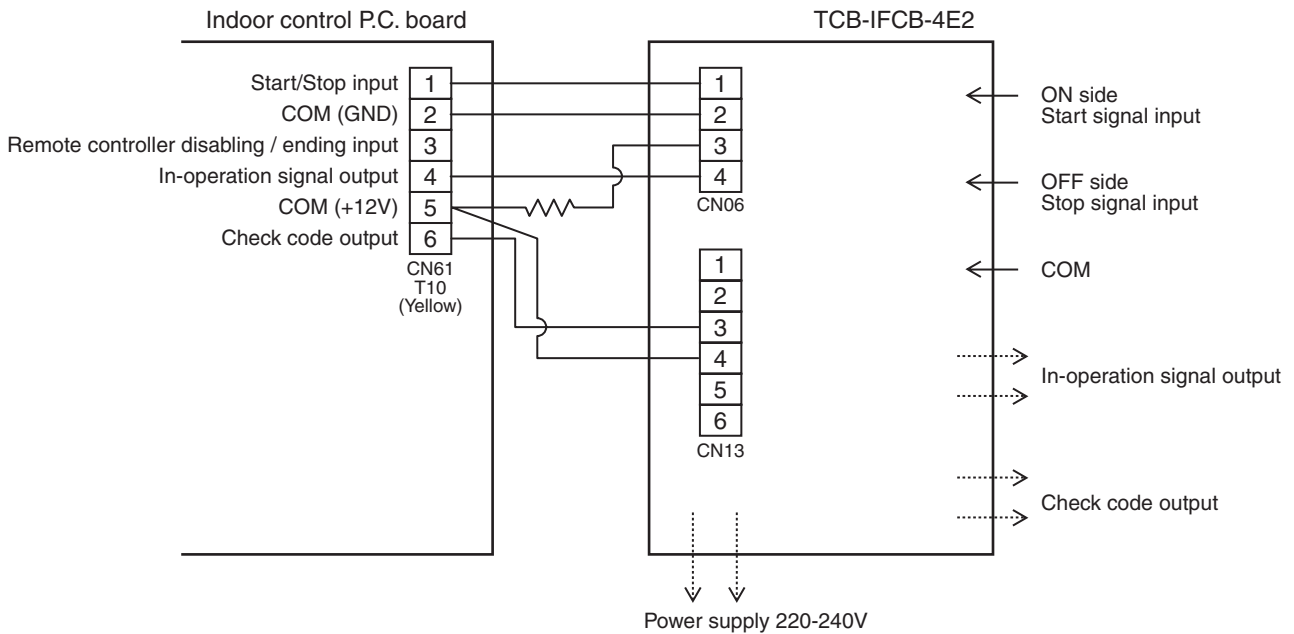

## ■ Ventilating fan control from remote controller

### [Function]

- The start / stop operation can be operated from the wired remote controller when air to air heat exchanger or ventilating fan is installed in the system.
- The fan can be operated even if the indoor unit is not operating.
- Use a fan which can receive the no-voltage normally-open contact as an outside input signal.
- In a group control, the units are collectively operated and they cannot be individually operated.

### 1. Operation

Handle a wired remote controller in the following procedure.

- \* Use the wired remote controller during stop of the system.
- \* Be sure to set up the wired remote controller to the header unit. (Same in group control)
- \* In a group control, if the wired remote controller is set up to the header unit, both header and follower units are simultaneously operable.

#### <RBC-AMT\*\*\*>

- 1 Push concurrently**  +  +  **buttons for 4 seconds or more.**

The unit No. displayed firstly indicates the header indoor unit address in the group control. In this time, the fan of the selected indoor unit turns on.

- 2 Every pushing**  **button (left side of the button), the indoor unit numbers in group control are displayed successively.**

In this time, the fan of the selected indoor unit only turns on.

- 3 Using the setup temp**  or  **button, specify the CODE No. 31.**

- 4 Using the timer time**  or  **button, select the SET DATA. (At shipment: 0000)**

The setup data are as follows:

SET DATA	Handling of operation of air to air heat exchanger or ventilating fan
<b>0000</b>	Unavailable (At shipment)
<b>0001</b>	Available

- 5 Push**  **button. (OK if display goes on.)**

- To change the selected indoor unit, go to the procedure 2 ).
- To change the item to be set up, go to the procedure 3 ).

- 6 Pushing**  **returns the status to the usual stop status.**

- \* The ventilating fan control may be unavailable depending on the remote controllers. (RBC-ASCU11-\* does not have this function.)

### 2. Wiring

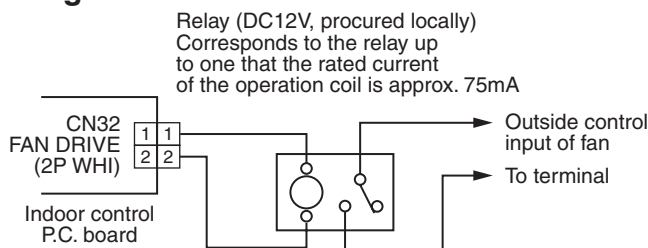

**Note)** Determine the cable length between the indoor control P.C. board and the relay within 2m.

## ■ Auto-off feature control

### [Function]

- This function controls the indoor units individually. It is used when the start operation from outside is unnecessary but the stop operation is necessary.
  - A card switch box or card lock helps protect customers from forgetting to turn off the indoor unit. (not including the following Card Input 3)
  - It is connected with connector on the indoor control P.C. board, and switched with the Code No. and jumper wire setup for use.
  - Available connectors are CN61 or CN73. For models without CN73, CN4 on the optional Application control kit (TCB-PCUC2E) can be used.
- \* Leaving-ON prevention control cannot be set with both CN61 and CN73 (CN4).  
If both of them are set, CN73 (CN4) setting automatically turns to a factory default.

### [Setup method]

#### (1) Wiring

##### Connecting to the CN61 connector

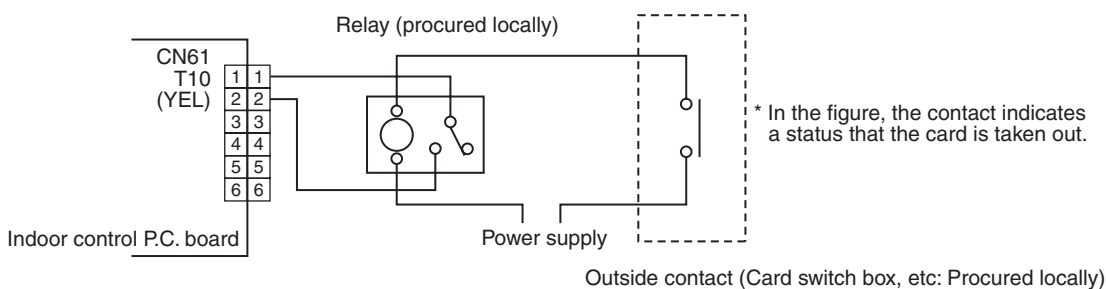

**NOTE)** Determine the cable length between the indoor control P.C. board and the relay within 3m.

##### Connecting to the Application control kit (TCB-PCUC2E, connector : CN4)

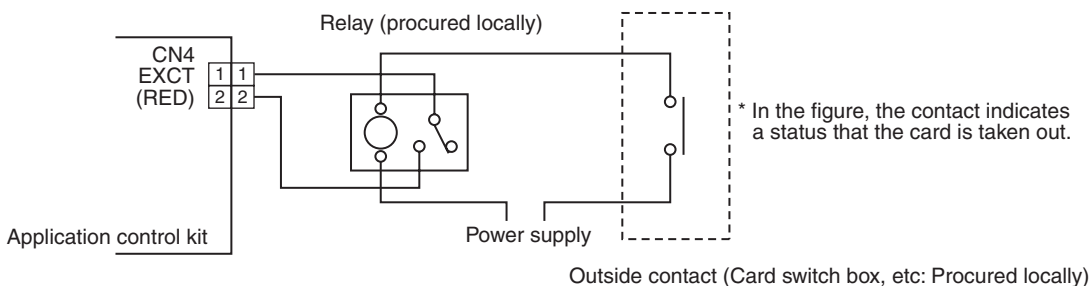

**NOTE)** Determine the cable length between the indoor control P.C. board and the relay within 3m.

#### (2) Code (DN) setup

Set Code (DN) according to "8-5. Method to set indoor unit function DN code".

Connector	Jumper wire (J01)	Code No. (DN)	Set data	Function
CN61	Short-circuit (Factory default)	002E	0000 (Factory default)	"HA normal setup" (pulse)
			0001	"Card Input 1" setup
			0003	"Card Input 2" setup
	Open-circuit (cut)		0005	"Card Input 5" setup
			0000 (Factory default)	"HA normal setup" (Static)
			0001	"Card Input 3" setup
CN73 (CN4)	Short-circuit (Factory default) or Open-circuit (cut)	000b	0003	"Card Input 4" setup
			0000 (Factory default)	"EXCT demand" setup (Forced thermostat-OFF)
			0002	"Card Input 3" setup
			0004	"Card Input 4" setup
			0007	"Card Input 5" setup
			0008	"Card Input 1" setup
0009	"Card Input 2" setup			

\* If you set "Card Input 1 to 5" for Code No. of CN61 and CN73, Code No. 000b setup becomes unavailable and the functions of Card Input 1 to 5 in CN73 cannot be used.

## [Control items]

Function	External contact terminal	
	Close (Status that card is inserted)	Open (Status that card is taken out)
Card Input 1	Manual prohibition release (Manual operation)	Manual prohibition (Operation stop)
Card Input 2	Manual prohibition release (Automatic operation)	Manual prohibition (Operation stop)
Card Input 3	Operation status continues (Do nothing)	Operation status continues and setting temperature changes (COOL/DRY: 29°C, HEAT: 18°C)
Card Input 4	Manual prohibition release (The status returns to operating condition before removing the card.)	Manual prohibition (Operation stop)
Card Input 5	<p>1) To change a setting temperature by changing data at DN code No. 172 to 174.</p> <p>2) The operation mode can be set by changing data (0000, 0001, 0002) at DN code No. 16b.</p> <p>0000: operation mode is the same at the current mode. (factory setting default)</p> <p>0001: operation mode returns to the previous mode when card was inserted. (in case of the previous mode is off operation, the operation mode is also off.)</p> <p>0002: operation mode starts at the same previous mode when the card was inserted. (the operation mode is on operation even the previous mode is off operation.)</p> <p>See contents below for DN settings and detailed operations.</p>	<p>1) To change a setting temperature, fan speed and wind direction by changing data at DN code No. 16C to 171.</p> <p>2) The operation mode can be set by changing data (0000, 0001) at DN code No. 16A.</p> <p>0000: operation mode is the same at the current mode. (factory setting default)</p> <p>0001: operation automatically starts.</p> <p>See contents below for DN settings and detailed operations.</p>

\* For the card switch box that does not involve contact operation described above, convert signals with a relay including a normally-closed contact.

## [Card input setup.5 Code (DN)]

DN	Item	Description	At shipment
16C	Open mode Set temp. (Cool, Dry)	-0015 : -15°C to 0060 : 60°C	0027 : 27°C
16d	Open mode Set temp. (Heat)	-0015 : -15°C to 0060 : 60°C	0020 : 20°C
16E	Open mode Set temp. (Auto)	-0015 : -15°C to 0060 : 60°C	0024 : 24°C
16F	Open mode Fan speed (All operation mode)	0000 : No change 0001 : HH 0002 : H 0003 : L	0000 : No change
170	Open mode Wind direction (Cool, Dry, Fan)	0000 : No change 0001 : F1 0002 : F2 0003 : F3	0000 : No change
171	Open mode Wind direction (Heat)	0000 : No change 0001 : F1 0002 : F2 0003 : F3 0004 : F4 0005 : F5	0000 : No change
16A	Open mode Operation	0000 : No change 0001 : Run operation	0000 : No change
172	Close mode Set temp. (Cool, Dry)	-0015 : -15°C to 0060 : 60°C	0024 : 24°C
173	Close mode Set temp. (Heat)	-0015 : -15°C to 0060 : 60°C	0024 : 24°C
174	Close mode Set temp. (Auto)	-0015 : -15°C to 0060 : 60°C	0024 : 24°C
16b	Close mode Operation	0000 : No change 0001 : Card ON mode operation 0002 : Run operation (Card ON mode setting)	0000 : No change

### [The example of Card Input 5 setting]

Case.	Code No. (DN) setting									External contact terminal	
	[16A] data	[16b] data	[16C] data	[16d] data	[16F] data	[170] data	[171] data	[172] data	[173] data	Close (Status that card is inserted)	Open (Status that card is taken n out)
(1)	0000	0000	0027	0020	0000	0000	0000	0024	0024	<ul style="list-style-type: none"> <li>The operation mode continues running at the same as the current mode.</li> <li>The setting temperature of cooling/dry and heating mode is changed to 24°C and 24°C respectively due to change in code No. 172, 173.</li> </ul>	<ul style="list-style-type: none"> <li>The operation mode continues running at the same as the current mode.</li> <li>The setting temperature of cooling/dry and heating mode is changed to 27°C and 20°C respectively due to change in code No. 16C, 16d.</li> </ul>
(2)*	0000	0001	0027	0020	0003	0001	0001	0024	0024	<ul style="list-style-type: none"> <li>The operation mode is running at the same mode as the last time when the card was inserted due to change in code no. 16b.</li> <li>* The operation mode will be off if the mode at the last time was in off operation. Also, the fan speed will the same as the last time when the card is inserted.</li> <li>The setting temperature of cooling/dry and heating mode is changed to 24°C and 24°C respectively due to change in code No. 172, 173.</li> </ul>	<ul style="list-style-type: none"> <li>The operation mode continues running at the same as the current mode.</li> <li>The setting temperature of cooling/dry and heating mode is changed to 27°C and 20°C respectively due to change in code no. 172, 173.</li> <li>The fan speed for all operation modes is changed due to change in code no.16F.</li> <li>The wind direction of Cooling/dry/fan and heating mode are changed due to change in code No. 170, 171 respectively.</li> </ul>
(3)*	0000	0002	0027	0020	0003	0001	0001	0024	0024	<ul style="list-style-type: none"> <li>The operation mode is running at the same mode as the last time when the card was inserted. Also, the operation mode will be on even the mode was in off operation at the last time due to change in code no. 16B.</li> <li>* The fan speed will the same as the last time when the card is inserted.</li> <li>The setting temperature of cooling/dry and heating mode is changed to 24°C and 24°C respectively due to change in code No. 172, 173.</li> </ul>	Same operation as case (2)
(4)	0001	0000	0027	0020	0003	0001	0001	0024	0024	<ul style="list-style-type: none"> <li>The operation mode continues running at the same as the current mode.</li> <li>The setting temperature of cooling/dry and heating mode is changed to 24°C and 24°C respectively due to change in code No. 172, 173.</li> </ul>	<ul style="list-style-type: none"> <li>Due to change in code no. 16A, the operation mode will be as below.</li> <li>When the operation is ON, the operation mode will continue running at the same as the current mode.</li> <li>When the operation is OFF, the air conditioner will turn on automatically.</li> <li>The setting temperature of cooling/dry and heating mode is changed to 27°C and 20°C respectively due to change in code No. 172, 173.</li> <li>The fan speed for all operation modes is changed due to change in code no.16F.</li> <li>The wind direction of Cooling/dry/fan and heating mode are changed due to change in code No. 170, 171 respectively.</li> </ul>

\* The history operation mode is only recorded when the card is inserted even if the operation mode is changed when the card is taken out, there is no related to the history operation mode.

## ■ Power peak-cut from indoor unit

When the relay is turned on, a forced thermostat OFF operation starts.

- For indoor P.C. boards other than MCC-1643, the "EXCT" is input with connector CN73 on the P.C. board. MCC-1643 requires Application control kit (TCB-PCUC2E) for input of a forced thermostat OFF "EXCT". Please refer to the manual of Application control kit for a detailed setting.

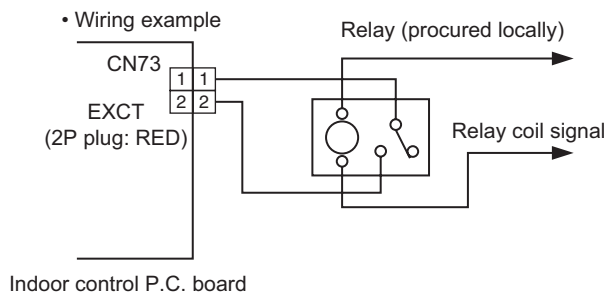

**Note)** Determine the cable length between the indoor or outdoor control P.C. board and the relay within 2 m.



## ■ Notice code signal

Notice code is a function dedicated to TU2C-Link communication.  
See service manual for u series outdoor unit for details of Notice code.

### [Function]

- Notice Code is issued if there is signal input to connector of outdoor unit P.C. board. This can be used in cases such as when confirming state of outdoor unit (filter clogging, etc.) by air conditioner system.
- Connector that can be used is CN61 or CN73. CN4 of separately-sold "option input/output P.C. board (TCB-PCUC2E)" can be used for models that do not have CN73.
- Used by switching functions with settings of Code No. (DN Code).
- Notice Code is continuously issued while input signal is ON.

### [Setup method]

#### (1) Wiring

##### Connecting to the CN61 connector

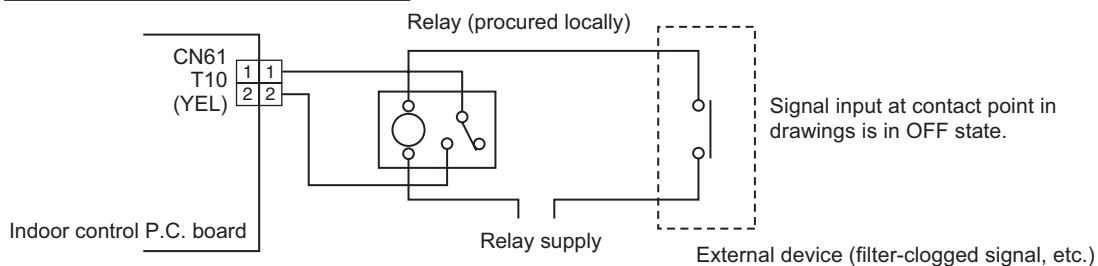

**Note)** Determine the cable length between the indoor control P.C. board and the relay within 3m.

##### Connecting to the Application control kit (TCB-PCUC2E, connector : CN4)

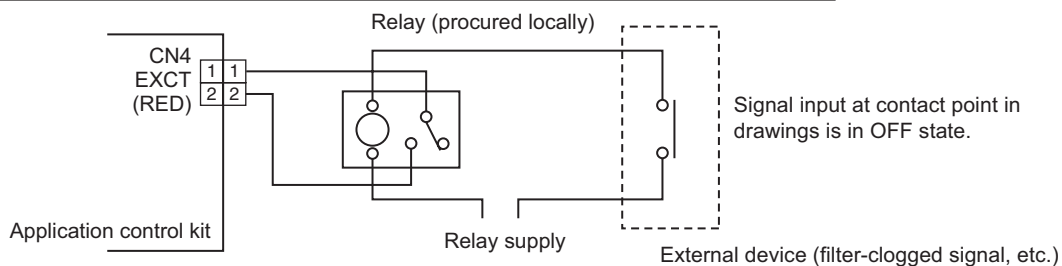

**Note)** Determine the cable length between the indoor control P.C. board and the relay within 3m.

#### (2) Code (DN) setup and Notice code

Set Code (DN) according to "8-5. Method to set indoor unit function DN code".

Connector	Code No. (DN)	Set data	Notice code
CN61	002E	0004	201
CN73 (CN4)	000B	0006	202

\* Setting of Code No. (DN Code) is necessary to display Notice code mark at remote controller.  
Set data corresponding to Notice code to be used to one of Code No. 180 to 189, in accordance with following table.  
In case where data other than 0000 is already set, set to other Code No. (DN Code).

Code No. (DN)	Set data	Notice code
0180	0000	OFF (Factory default)
to	0129	201
0189	0130	202

\* It may take up to ten minutes to be displayed on remote controller after Notice code is issued.

## Manual address setting using the remote controller

Procedure when setting indoor units' addresses first under the condition that indoor wiring has been completed and outdoor wiring has not been started (manual setting using the remote controller)

### Wiring example of 2 refrigerant lines

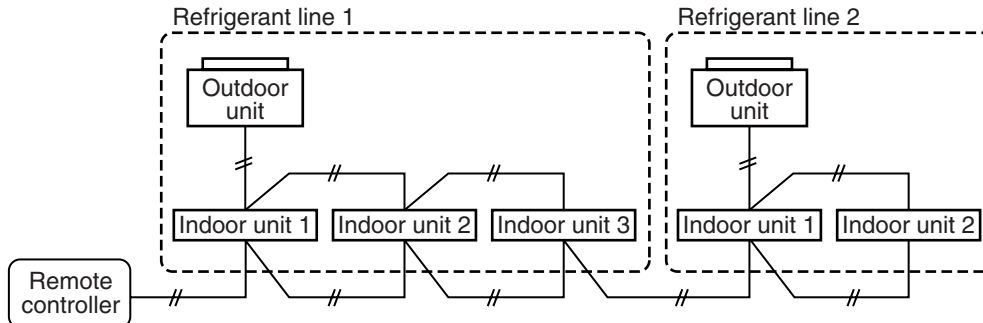

Line (system) address	1	1	1	2	2
Indoor unit address	1	2	3	1	2
Group address	1 Header unit	2 Follower unit	2 Follower unit	2 Follower unit	2 Follower unit

In the example above, disconnect the remote controller connections between the indoor units and connect a wired remote controller to the target unit directly before address setting.

<RBC-AMT\*\*\*>

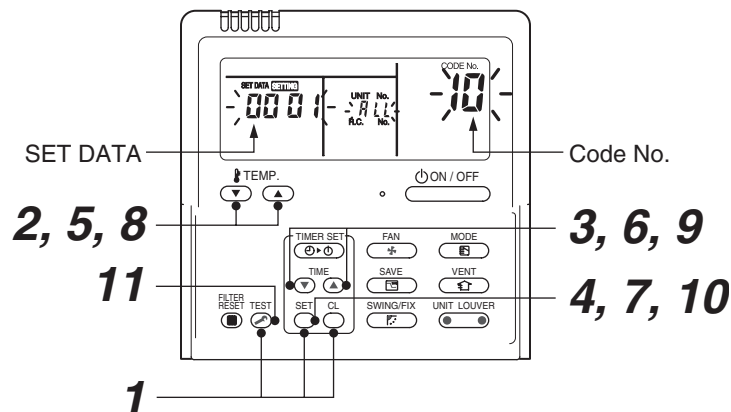

Pair the indoor unit to set and the remote controller one-to-one.

Turn on the power.

- 1 Push and hold the **SET**, **CL** and **TEST** buttons at the same time for more than 4 seconds.  
LCD starts flashing.

<Line (system) address>

- 2 Push the **TEMP.**  $\downarrow$  /  $\uparrow$  buttons repeatedly to set the **CODE No.** to **12**.
- 3 Push the **TIME**  $\downarrow$  /  $\uparrow$  buttons repeatedly to set a system address.  
(Match the address with the address on the interface P.C. board of the header outdoor unit in the same refrigerant line.)
- 4 Push **SET** button.  
(It is OK if the display turns on.)

<Indoor unit address>

- 5 Push the TEMP. (▼) / (▲) buttons repeatedly to set the CODE No. to 13.
- 6 Push the TIME (▼) / (▲) buttons repeatedly to set an indoor unit address.
- 7 Push the  button.  
(It is OK if the display turns on.)

<Group address>

- 8 Push the TEMP. (▼) / (▲) buttons repeatedly to set the CODE No. to 14.
- 9 Push the TIME (▼) / (▲) buttons repeatedly to set a group address. If the indoor unit is individual, set the address to 0000 ; header unit, 0001 ; follower unit, 0002 .

Individual	: 0000	} In case of group control
Header unit	: 0001	
Follower unit	: 0002	

- 10 Push the  button.  
(It is OK if the display turns on.)

- 11 Push the  button.  
The address setting is complete.  
( **SETTING** flashes. You can control the unit after **SETTING** has disappeared.)

<RBC-ASCU11-\*>

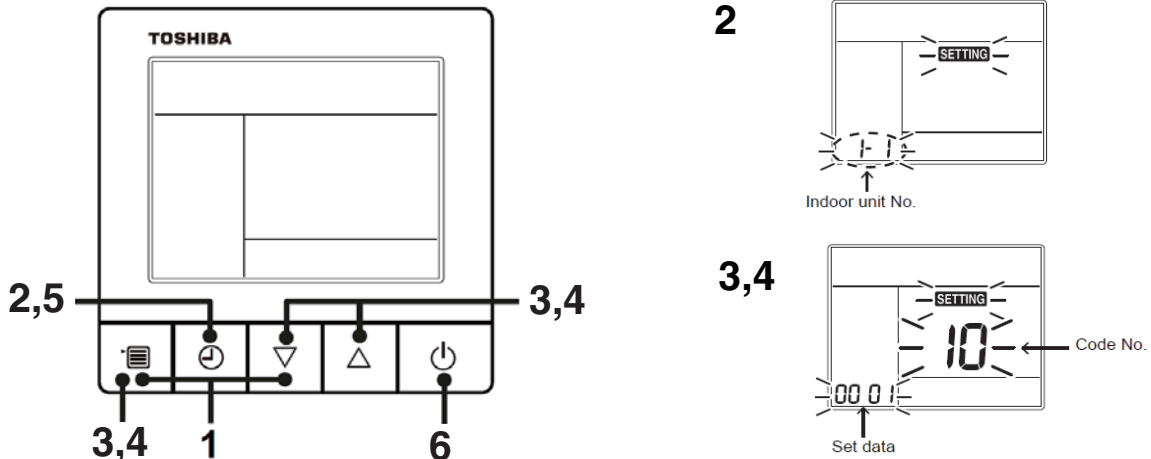

- 1 Push and hold the [menu + ▼] buttons at same time for more than 10 seconds.
- 2 Push the [OFF timer] button to confirm the selected indoor unit.

<Line (system) address>

- 3 Push the [menu] button until the CODE No. flashes. And using the [▼ or ▲] buttons, specify the CODE No.12.
- 4 Push the [menu] button until the SET DATA flashes. And using the [▼ or ▲] buttons, set a system address.
- 5 Push the [OFF timer] button to confirm the SET DATA.

<Indoor unit address>

- 3** Push the [menu] button until the CODE No. flashes. And using the [ ▽ or △ ] buttons, specify the CODE No.13.
- 4** Push the [menu] button until the SET DATA flashes. And using the [ ▽ or △ ] buttons, set an indoor unit address.
- 5** Push the [OFF timer] button to confirm the SET DATA.

<Group address>

- 3** Push the [menu] button until the CODE No. flashes. And using the [ ▽ or △ ] buttons, specify the CODE No.14.
- 4** Push the [menu] button until the SET DATA flashes. And using the [ ▽ or △ ] buttons, set a group address.  
If the indoor unit is individual, set the address to 0000. (header unit : 0001, follower unit : 0002)  
Individual :0000  
Header unit :0001 } In case of group control  
Follower unit :0002 }
- 5** Push the [OFF timer] button to confirm the SET DATA.
- 6** When all the settings have been completed, push the [ON/OFF] button to return to normal mode.

**NOTE**

**<In the case of combining with outdoor units of Super Modular Multi System u series (SMMS-u)>**

- Turn ON DIP switch 1 of SW100 on the header outdoor unit interface P.C. board the lowest system address number.
- After finishing all the settings above, set the address of the central control devices. (For the setting of the central control address, refer to the installation manual of the central control devices.)

**<In the case of combining with outdoor units other than Super Modular Multi System u series (SMMS-u)>**

- Set a system address for the header outdoor unit of each line with SW13 and 14 of their interface P.C. boards.
- Turn off dip switch 2 of SW30 on the interface P.C. boards of all the header outdoor units connected to the same central control, except the unit that has the lowest address. (For unifying the termination of the wiring for the central control of indoor and outdoor units)
- Connect the relay connectors between the [U1, U2] and [U3, U4] terminals on the header outdoor unit of each refrigerate line.
- After finishing all the settings above, set the address of the central control devices. (For the setting of the central control address, refer to the installation manuals of the central control devices.)

## ■ Confirming the indoor unit addresses and the position of an indoor unit using the remote controller

### ◆ Confirming the numbers and positions of indoor units

To know the indoor unit addresses though position of the indoor unit is recognized

- ▼ When the unit is individual (the indoor unit is paired with a wired remote controller one-to-one), or it is a group-controlled one.

<RBC-AMT\*\*\*>

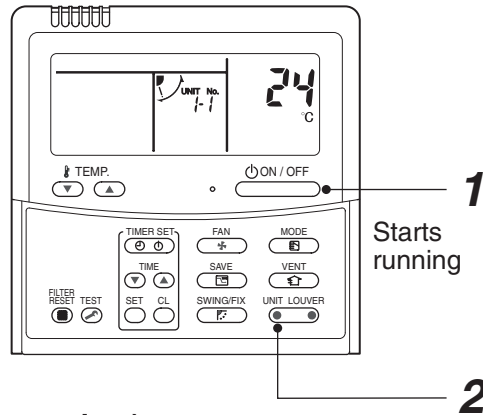

(Execute it while the units are running.)

**1** Push the  button if the units stop.

**2** Push the  button (left side of the button).

A unit numbers **1-1** is indicated on the LCD (it will disappear after a few seconds). The indicated number shows the system address and indoor unit address of the unit.

When 2 or more indoor units are connected to the remote controller (group-controlled units), a number of other connected units appears each time you push the  button (left side of the button).

<RBC-ASCU11-\*>

There is no such function in the remote controller.

## ◆ To find an indoor unit's position from its address



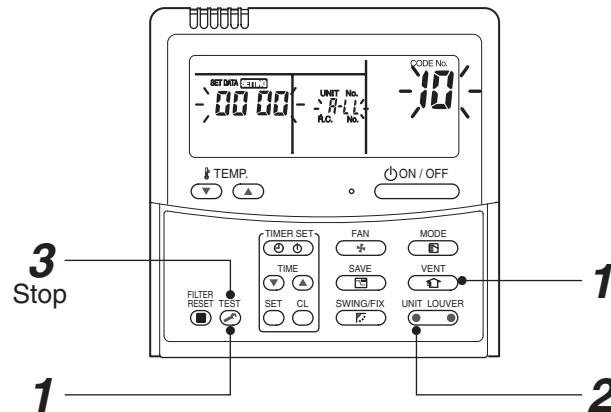

### ▼ When checking unit numbers controlled as a group

<RBC-AMT\*\*\*>







**(Execute it while the units are stopped.)**

The indoor unit numbers in a group are indicated one after another. The fan and louvers of the indicated units are activated.

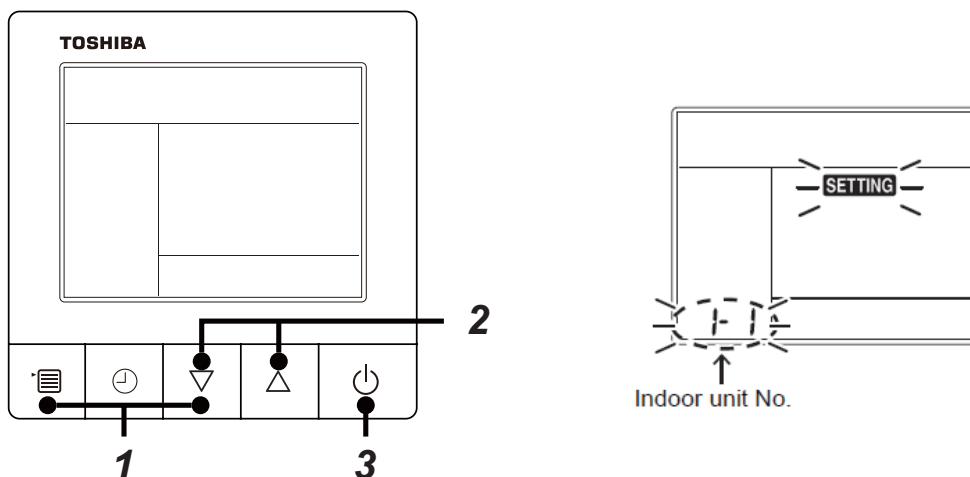
- 1** Push and hold the  and  buttons at the same time for more than 4 seconds.
  - **ALL** appears on UNIT No. on the LCD display.
  - The fans and louvers of all the indoor units in the group are activated.
- 2** Push the  button (left side of the button). Each time you push the button, the indoor unit numbers are indicated one after another.
  - The first-indicated unit number is the address of the header unit.
  - Only the fan and louvers of the indicated indoor unit are activated.
- 3** Push the  button to finish the procedure.  
All the indoor units in the group stop.

<RBC-ASCU11-\*>



- 1** Push and hold the [menu + ] buttons at same time for more than 10 seconds.  
e.g.)A unit number 1-1 is indicated on the LCD. The indicated number shows the system address and indoor unit address of the unit.
- 2** When 2 or more indoor units are connected to the remote controller (group-controlled units), a number of other connected units appears each time you push the [ or ] buttons.
- 3** Push the [ON/OFF] button, return to the normal mode.

- ▼ To check all the indoor unit addresses using an arbitrary wired remote controller.  
(When communication wirings of 2 or more refrigerant lines are interconnected for central control)

<RBC-AMT\*\*\*>

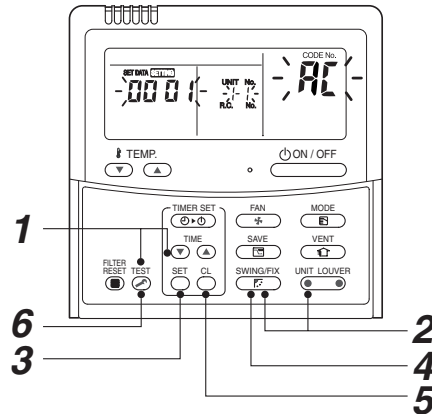

(Execute it while the units are stopped.)

You can check indoor unit addresses and positions of the indoor units in a single refrigerant line. When an outdoor unit is selected, the indoor unit numbers of the refrigerant line of the selected unit are indicated one after another and the fan and louvers of the indicated indoor units are activated.

- 1** Push and hold the TIME and <sup>TEST</sup> buttons at the same time for more than 4 seconds. At first, the line 1 and CODE No. AC (Address Change) are indicated on the LCD display. (Select an outdoor unit.)
  - 2** Push the <sup>UNIT LOUVER</sup> button (left side of the button) and <sup>SWING/FIX</sup> buttons repeatedly to select a system address.
  - 3** Push the <sup>SET</sup> button to confirm the system address selection.
    - The address of an indoor unit connected to the selected refrigerant line is indicated on the LCD display and its fan and louvers are activated.
  - 4** Push the <sup>UNIT LOUVER</sup> button (left side of the button). Each time you push the button, the indoor unit numbers of the selected refrigerant line are indicated one after another.
    - Only the fan and louvers of the indicated indoor unit are activated.
- ◆ To select another system address
- 5** Push the <sup>CL</sup> button to return to step 2.
    - After returning to step 2, select another system address and check the indoor unit addresses of the line.
  - 6** Push the <sup>TEST</sup> button to finish the procedure.

<RBC-ASCU11-\*>

There is no such function in the remote controller.

## ◆ Changing the indoor unit address using a remote controller

To change an indoor unit address using a wired remote controller.

- ▼ The method to change the address of an individual indoor unit (the indoor unit is paired with a wired remote controller one-to-one), or an indoor unit in a group. (The method is available when the addresses have already been set automatically.)

<RBC-AMT\*\*\*>

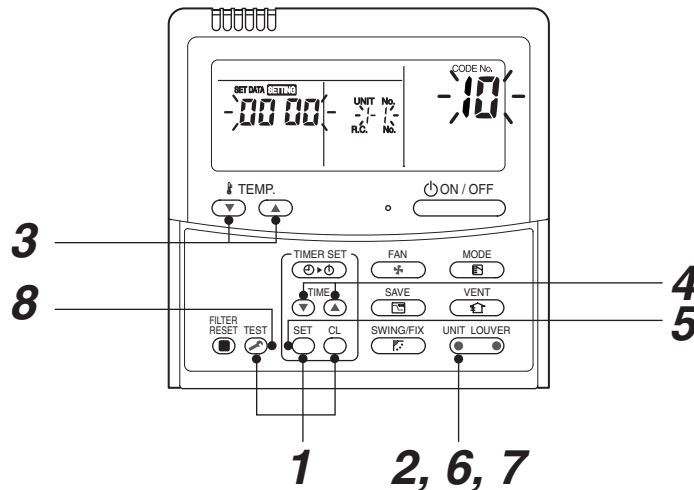

(Execute it while the units are stopped.)

- 1 Push and hold the <sup>SET</sup> ○, <sup>CL</sup> ○, and <sup>TEST</sup> ⚙ buttons at the same time for more than 4 seconds. (If 2 or more indoor units are controlled in a group, the first indicated UNIT No. is that of the head unit.)
- 2 Push the <sup>UNIT LOUVER</sup> ⬅ button (left side of the button) repeatedly to select an indoor unit number to change if 2 or more units are controlled in a group. (The fan and louvers of the selected indoor unit are activated.) (The fan of the selected indoor unit is turned on.)
- 3 Push the TEMP. ▼ / ▲ buttons repeatedly to select **13** for CODE No.
- 4 Push the TIME ▼ / ▲ buttons repeatedly to change the value indicated in the SET DATA section to that you want.
- 5 Push the <sup>SET</sup> ○ button.
- 6 Push the <sup>UNIT LOUVER</sup> ⬅ button (left side of the button) repeatedly to select another indoor UNIT No. to change. Repeat steps 4 to 6 to change the indoor unit addresses so as to make each of them unique.
- 7 Push the <sup>UNIT LOUVER</sup> ⬅ button (left side of the button) to check the changed addresses.
- 8 If the addresses have been changed correctly, push the <sup>TEST</sup> ⚙ button to finish the procedure.



<RBC-ASCU11-\*>

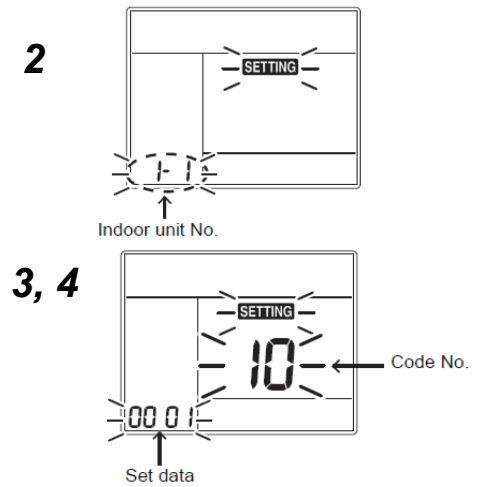
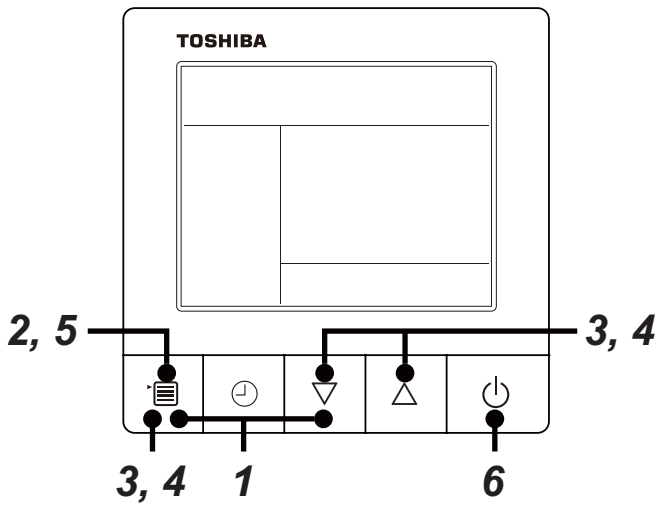

- 1** Push and hold the [menu + ▽] buttons at same time for more than 10 seconds.
- 2** Push the [OFF timer] button to confirm the selected indoor unit.
- 3** Push the [menu] button until the CODE No. flashes. And using the [▽ or △] buttons, specify the CODE No.13.
- 4** Push the [menu] button until the SET DATA flashes. And using the [▽ or △] buttons, set an indoor unit address.
- 5** Push the [OFF timer] button to confirm the SET DATA.
- 6** When all the settings have been completed, push the [ON/OFF] button, return to normal mode.

- ▼ To change all the indoor unit addresses using an arbitrary wired remote controller. (The method is available when the addresses have already been set automatically.)

(When communication wirings of 2 or more refrigerant lines are interconnected for central control)

**NOTE**  
You can change the addresses of indoor units in each refrigerant line using an arbitrary wired remote controller.

\* Enter the address check / change mode and change the addresses.

<RBC-AMT\*\*\*>

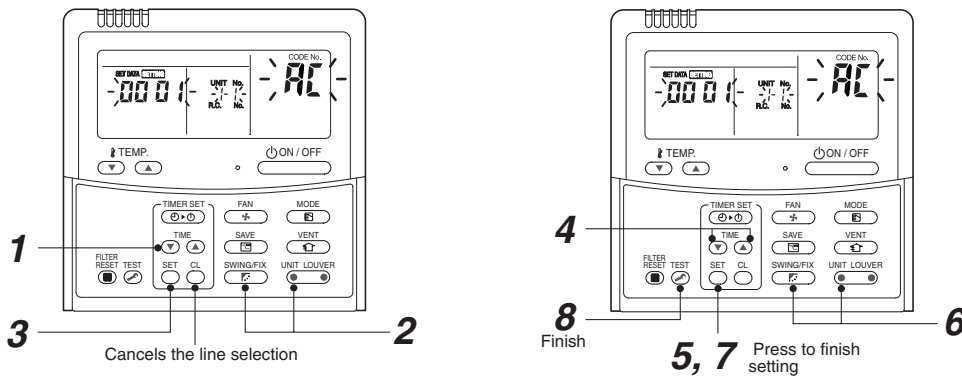

If no number appears on UNIT No., no outdoor unit exists on the line. Push button and select another line following step 2.

(Execute it while the units are stopped.)

- 1 Push and hold the TIME (▼) / (▲) buttons at the same time for more than 4 seconds. At first, the line 1 and CODE No. AC (Address Change) are indicated on the LCD display.
- 2 Push the UNIT LOUVER button (left side of the button) and the SWING/FIX buttons repeatedly to select a system address.
- 3 Push the SET button.
  - The address of one of the indoor units connected to the selected refrigerant line is indicated on the LCD display and the fan and louvers of the unit are activated. At first, the current indoor unit address is displayed in SET DATA. (No system address is indicated.)
- 4 Push the TIME (▼) / (▲) buttons repeatedly to change the value of the indoor unit address in SET DATA. Change the value in SET DATA to that of a new address.
- 5 Push the SET button to confirm the new address on SET DATA.
- 6 Push the UNIT LOUVER button (left side of the button) repeatedly to select another address to change. Each time you push the button, the indoor unit numbers in a refrigerant line are indicated one after another. Only the fan and louvers of the selected indoor unit are activated. Repeat steps 4 to 6 to change the indoor unit addresses so as to make each of them unique.
- 7 Push the SET button. (All the segments on the LCD display light up.)
- 8 Push the TEST button to finish the procedure.

<RBC-ASCU11-\*>

There is no such function in the remote controller.

◆ Check code clearing function

How to clear the check code using the wired remote controller

<RBC-AMT\*\*\*>

▼ Clearing a check code of the outdoor unit

Clear the currently detected outdoor unit for each refrigerant line to which the indoor unit controlled by the remote controller is connected. (The indoor unit check code is not cleared.)  
Use the service monitoring function of the remote controller.

- 1 Push and hold the **CL** , and **TEST** for 4 seconds or longer to enter the service monitoring mode.
- 2 Push the **TEMP.** button to set CODE No. to "FF".
- 3 The display in A of the following figure counts down as follows at 5-second intervals:  
"0005" → "0004" → "0003" → "0002" → "0001" → "0000".  
The check code is cleared when "0000" appears.  
However, the display counts down from "0005" again.
- 4 Push the **TEST** to return the display to normal.

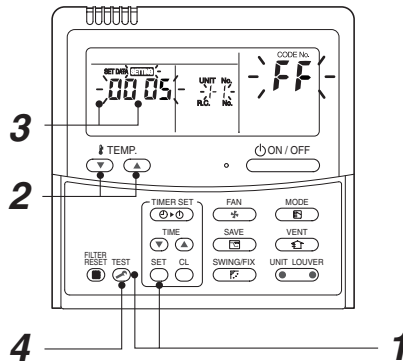

▼ Clearing a check code of the indoor unit

Push the **ON/OFF** button on the remote controller.

(Only the check code of the indoor unit controlled by the remote controller will be cleared.)

<RBC-ASCU11-\*>

▼ Clearing a check code of the outdoor unit

Clear the currently detected outdoor unit for each refrigerant line to which the indoor unit controlled by the remote controller is connected. (The indoor unit check code is not cleared.)  
Use the service monitoring function of the remote controller.

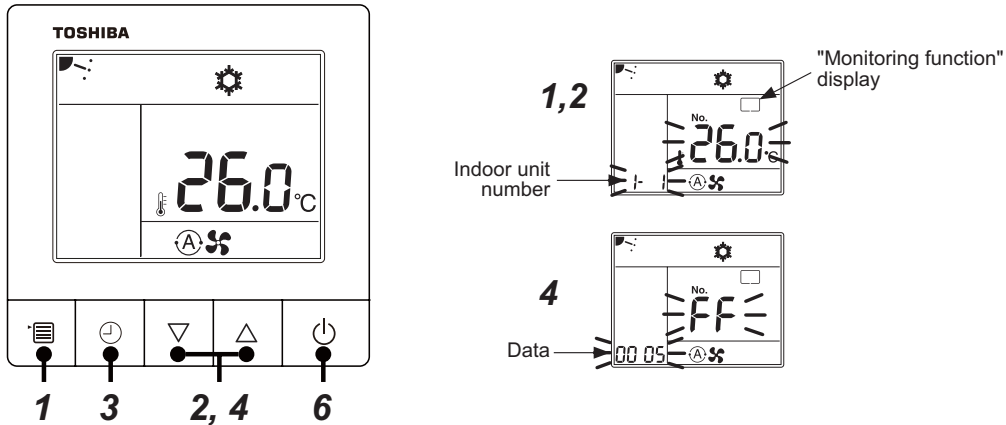

**1** Push the [menu] button for over 10 seconds.

**2** Every pushing [▽ or △] buttons, the indoor unit numbers in group control are displayed successively.

**3** Push the [OFF timer] button to confirm the selected indoor unit.

**4** Every pushing [▽ or △] buttons to set CODE No. to "FF"

**5** The display in A of the following figure counts down as follows at 5-second intervals:  
"0005" → "0004" → "0003" → "0002" → "0001" → "0000"

The check code is cleared when "000" appears.

However, the display counts down from "005" again.

**6** After you have finished checking, push the [ON/OFF] button to return to normal mode.

▼ Clearing a check code of the indoor unit

Push the ON / OFF button on the remote controller.

(Only the check code of the indoor unit controlled by the remote controller will be cleared.)



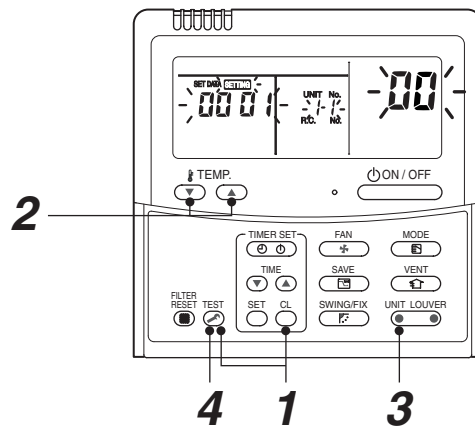

## ▼ Monitoring function of wired remote controller

<RBC-AMT\*\*\*>



### Content

Enter the service monitoring mode using the remote controller to check the sensor temperature or operation status of the remote controller, indoor unit, and outdoor unit.

- 1** Push and hold the , and  for 4 seconds or longer to enter the service monitoring mode.  
The service monitor lights up. The CODE No. **00** appears at first.
- 2** Push the  button to change to CODE No. of the item to monitor. Refer to the next page for CODE No.
- 3** Push the left part of the  button (left side of the button) to change to the item to monitor. Monitor the sensor temperature or operation status of the indoor unit and outdoor unit in the refrigerant line.
- 4** Push the  button to return the display to normal.

<RBC-ASCU11-\*>

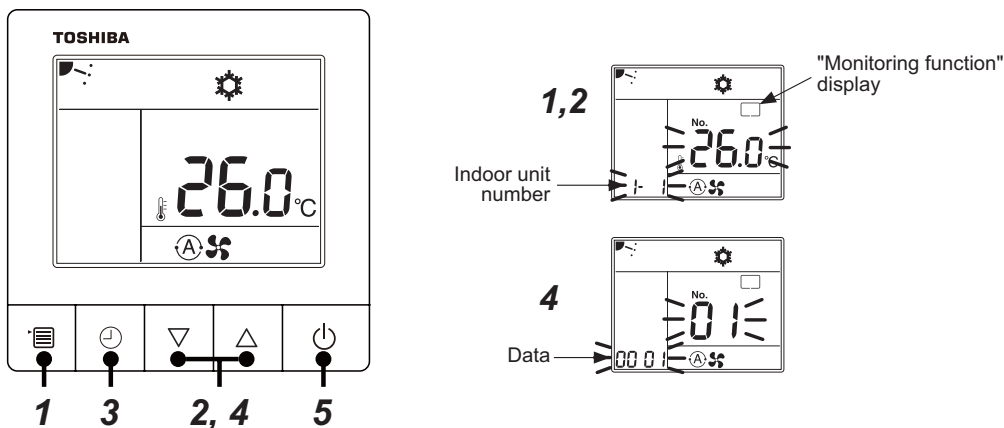

- 1** Push the [menu] button for over 10 seconds. "Monitoring function" is displayed on a screen.
- 2** Every pushing [▽ or △] buttons, the indoor unit numbers in group control are displayed successively.
- 3** Push the [OFF timer] button to confirm the selected indoor unit.
- 4** Every pushing [▽ or △] buttons, CODE No. of the item is changed successively.
- 5** After you have finished checking, push the [ON/OFF] button, return to normal mode.

## ◆ Indoor service monitor list

	Code No.	Data name	Display format	Unit	Remote controller display example
Indoor unit data *	00	Room temperature (Use to control)	×1	°C	
	01	Room temperature (Remote controller)	×1	°C	
	02	Indoor suction air temperature (TA)	×1	°C	
	03	Indoor coil temperature (TCJ)	×1	°C	
	04	Indoor coil temperature (TC2)	×1	°C	
	05	Indoor coil temperature (TC1)	×1	°C	
	06	Indoor discharge air temperature (TF) **	×1	°C	
	07	Indoor fan motor number of revolutions**	×1	rpm	[0600] = 600rpm
	08	Indoor PMV opening	×1/10	pls	[0150]=1500pls
	F3	Filter sign time	×1	h	[2500] = 2500h
	F9	Suction temperature of air to air heat exchanger (TSA) **	×1	°C	[0024] = 24°C
	FA	Outside air temperature (TOA) **	×1	°C	

\* When the units are connected to a group, data of the header indoor unit only can be displayed.

\*\* There is also a model which cannot be displayed.

- Refer to the service manual of an outdoor unit for "outdoor service monitor list".

# 9. TROUBLESHOOTING

## 9-1. Overview

(1) Before engaging in troubleshooting

(a) Applicable models

All Super Modular Multi System (SMMS-\*) models.

(Indoor units: MM\*-UP\*\*\*, Outdoor units: MMY-M\*P\*\*\*)

(b) Tools and measuring devices required

- Screwdrivers (Philips, flat head), spanners, long-nose pliers, nipper, pin to push reset switch, etc.
- Multimeter, thermometer, pressure gauge, etc.

(c) Things to check prior to troubleshooting (behaviors listed below are normal)

NO.	Behavior	Possible cause
1	A compressor would not start	<ul style="list-style-type: none"> <li>• The air conditioner is being controlled by the 3-minute protective function.</li> <li>• It is in standby status though the room temperature has reached the setup temperature.</li> <li>• It is being operated in timer mode or fan mode.</li> <li>• It is being in initial communication.</li> </ul>
2	An indoor fan would not start	<ul style="list-style-type: none"> <li>• The air conditioner is being controlled by the cool air discharge preventive function in "heating"?</li> </ul>
3	An outdoor fan would not start or would change speed for no reason	<ul style="list-style-type: none"> <li>• The air conditioner is being operated in "cooling" under the low outside air temperature.</li> <li>• It is being operated in defrost operation.</li> </ul>
4	An indoor fan would not stop	<ul style="list-style-type: none"> <li>• The air conditioner is being controlled by function of residual heat elimination being performed as part of the air conditioner shutdown process after heating operation.</li> </ul>
5	The air conditioner would not respond to a start/stop command from a remote controller	<ul style="list-style-type: none"> <li>• The air conditioner is being operated under external or remote controller.</li> </ul>

### CAUTION

The cooling performance may be declining considerably when total operating capacity of cooling indoor units is less than 4 HP while ambient temperature is below.

(2) Troubleshooting procedure

When a problem occurs, proceed with troubleshooting in accordance with the procedure shown below.

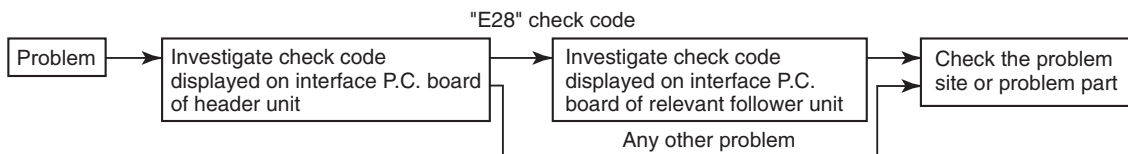

### NOTE

Rather than a product trouble (see the List of Check Codes below), the problem could have been caused by a microprocessor malfunction attributable to a poor quality of the power source or an external noise. Check for possible noise sources, and shield the remote controller wiring and signal wires as necessary.

## 9-2. Troubleshooting method

The remote controllers (main remote controller and central control device) and the interface P.C. board of an outdoor unit are provided with an a 7-segment display (outdoor interface P.C. board) to display operational status. Using this self-diagnosis feature, the trouble site / trouble part may be identified in the event of a trouble by following the method described below.

The list below summarizes check codes detected by various devices. Analyze the check code according to where it is displayed and work out the nature of the trouble in consultation with the list.

- When investigating a trouble on the basis of a display provided on the indoor remote controller or central control device - See the “central control device or main remote controller display” section of the list.
- When investigating a trouble on the basis of a display provided on an outdoor unit - See the “Outdoor 7-segment display” section of the list.
- When investigating a trouble on the basis of a wireless remote controller-controlled indoor unit - See the “Indicator light block” section of the list.

### List of check codes (indoor unit)

(Check code detected by indoor unit)

IPDU: Compressor / Fan inverter P.C. board

○: Lighting, ⊙: Flashing, ●: Goes off

ALT.: Flashing is alternately when there are two flashing LED

SIM: Simultaneous flashing when there are two flashing LED

Check code			Display of receiving unit				Typical trouble on site	Description of check code
Remote controller display	Outdoor 7-segment display		Indicator light block					
		Sub-code	Operation ⏻	Timer ⌚	Ready ⊙	Flash		
E03	—	—	⊙	●	●		Indoor-remote controller periodic communication check code	Communication from remote controller or network adaptor has been lost (so has central control communication).
E04	—	—	●	●	⊙		Indoor-outdoor periodic communication check code	Signals are not being received from outdoor unit.
E08	E08	Duplicated indoor address	⊙	●	●		Duplicated indoor address	Indoor unit detects address identical to its own.
E10	—	—	⊙	●	●		Communication trouble between indoor unit MCU	Communication trouble between main MCU and the motor microcomputer MCU
E11	—	—	⊙	●	●		Communication check code between Application control kit and indoor unit	Communication check code between Application control kit and indoor unit P.C. board
E18	—	—	⊙	●	●		Check cod in periodic communication between indoor header and follower unit	Periodic communication between indoor header and follower units cannot be maintained.
F01	—	—	⊙	⊙	●	ALT	Indoor heat exchanger temperature sensor (TCJ) check code	Heat exchanger temperature sensor (TCJ) has been open / short-circuit.
F02	—	—	⊙	⊙	●	ALT	Indoor heat exchanger temperature sensor (TC2) check code	Heat exchanger temperature sensor (TC2) has been open / short-circuit.
F03	—	—	⊙	⊙	●	ALT	Indoor heat exchanger temperature sensor (TC1) check code	Heat exchanger temperature sensor (TC1) has been open / short-circuit.
F10	—	—	⊙	⊙	●	ALT	Ambient temperature sensor (TA) check code	Ambient temperature sensor (TA) has been open / short-circuit.
F11	—	—	⊙	⊙	●	ALT	Discharge temperature sensor (TF) check code	Discharge temperature sensor (TF) has been open / short-circuit.
F29	—	—	⊙	⊙	●	SIM	P.C. board or other indoor check code	Indoor EEPROM is abnormal (some other trouble may be detected).
F30	—	—	⊙	⊙	○	ALT	Occupancy sensor trouble	Occupancy sensor trouble has been detected.
L03	—	—	⊙	●	⊙	SIM	Duplicated indoor group header unit	There is more than one header unit in group.
L07	—	—	⊙	●	⊙	SIM	Connection of group control cable to a single indoor unit	There is at least one a single indoor unit to which group control cable is connected.
L08	L08	—	⊙	●	⊙	SIM	Indoor group address not set	Address setting has not been performed for one or more indoor units (also detected at outdoor unit end).
L09	—	—	⊙	●	⊙	SIM	Indoor capacity not set	Capacity setting has not been performed for indoor unit.
L20	—	—	⊙	○	⊙	SIM	Duplicated central control address	There is duplication in central control address setting.
L30	L30	Detected indoor unit No.	⊙	○	⊙	SIM	Indoor external check code input (interlock)	Unit shutdown has been caused by external check code input (CN80).
P01	—	—	●	⊙	⊙	ALT	Indoor AC fan check code	Indoor AC fan check code is detected (activation of fan motor thermal relay).
P10	P10	Detected indoor unit No.	●	⊙	⊙	ALT	Indoor overflow check code	Float switch has been activated.
P12	—	—	●	⊙	⊙	ALT	Indoor DC fan check code	• Indoor DC fan check code (e.g. overcurrent or lock-up) is detected.
P31	—	—	⊙	●	⊙	ALT	Other indoor unit check code	Follower unit cannot be operated due to header unit alarm (E03 / L03 / L07 / L08).



(Check code detected by remote controller)

Check code			Display of receiving unit				Typical trouble site	Description of trouble
Remote control	Outdoor 7-segment display		Indicator light block					
		Sub-code	Operation ⏻	Timer ⌚	Ready ⊕	Flash		
E01	–	–	⊙	●	●		No master remote control, failure remote control communication (reception)	Signals cannot be received from indoor unit; master remote control has not been set (including two remote control).
E02	–	–	⊙	●	●		Failure remote control communication (transmission)	Signals cannot be transmitted to indoor unit.
E09	–	–	⊙	●	●		Duplicated master remote control	Both remote controls have been set as master remote control in two remote control (alarm and shutdown for header unit and continued operation for follower unit)

(Check code detected by central control device)

Check code			Display of receiving unit				Typical trouble site	Description of trouble
Central control	Outdoor 7-segment display		Indicator light block					
		Sub-code	Operation ⏻	Timer ⌚	Ready ⊕	Flash		
C05	–	–					Failure central control communication (transmission)	Central control device is unable to transmit signal due to duplication of central control device
C06	–	–						Failure central control communication (reception)
C12	–	–				–	Bracket alarm for general-purpose device control interface	Device connected to general-purpose device control interface is trouble.
P30 (L20)	–	–				(L20 is displayed.)	Communication Link	<ul style="list-style-type: none"> <li>• Duplication addresses of indoor units in central control device</li> <li>• With the combination of air conditioning system, the indoor unit may detect the check code of L20</li> </ul>

**Note:** The same trouble, e.g. a communication trouble, may result in the display of different check codes depending on the device that detects it. Moreover, check codes detected by the main remote controller / central control device do not necessarily have a direct impact on air conditioner operation.

### Flow selector unit (FS unit) Relation

(Check code detected by indoor unit)

Check code			Display of receiving unit				Typical trouble site	Description of trouble
Main remote control	Outdoor 7-segment display		Indicator light block					
		Sub-code	Operation ⏻	Timer ⌚	Ready ⊕	Flash		
E17	–	–	⊙	●	●		Communication trouble between indoor unit (s) and FS unit (s)	There is no communication from FS unit(s)
J03	–	–	●	⊙	⊙		Duplicated FS units	More than one FS units have been set up in one refrigerant line.
J10	–	–	●	⊙	⊙		FS unit overflow trouble	FS unit has been shutdown in one refrigerant line due to detection of overflow
J11	–	–	●	⊙	⊙		FS unit temperature sensor (TCS) trouble	FS unit temperature sensor (TCS) has been open/short-circuited.
L12	L12	–	⊙	○	⊙		FS unit(s) system trouble	FS unit(s) outside the application setting



## List of Check Codes (Outdoor Unit)

(Check code detected by outdoor interface - typical examples)

If "HELLO" is displayed on the outdoor 7-segment for 1 minute or more, turn off the power supply once and then turn on the power supply again after passage of 30 seconds or more. When the same symptom appears, it is considered there is a possibility of I/F board trouble.

○ : Lighting, ◎ : Flashing, ● : Goes off  
 ALT.: Flashing is alternately when there are two flashing LED  
 SIM: Simultaneous flashing when there are two flashing LED

Check code		Display of receiving unit		Typical problem site	Description of problem																																																																																										
Outdoor 7-segment display		Central control or main remote controller display	Indicator light block																																																																																												
Sub-code			Operation ⏻	Timer ⌚	Ready ⚙️	Flash																																																																																									
E06	Number of indoor units from which signal is received normally	E06	●	●	◎	Signal lack of indoor unit	<ul style="list-style-type: none"> <li>Indoor unit initially communicating normally fails to return signal (reduction in number of indoor units connected).</li> <li>In TU2C-LINK communication system, if the termination resistance is not set in any of the indoor units.</li> </ul>																																																																																								
E07	—	(E04)	●	●	◎	Indoor-outdoor communication circuit trouble	Signal cannot be transmitted to indoor units (→ indoor units left without communication from outdoor unit).																																																																																								
E08	Duplicated indoor address	(E08)	◎	●	●	Duplicated indoor address	More than one indoor unit are assigned same address (also detected at indoor unit end).																																																																																								
E12	01: Indoor-outdoor communication 02: Outdoor-outdoor communication	E12	◎	●	●	Automatic address starting trouble	<ul style="list-style-type: none"> <li>Indoor automatic address setting is started while automatic address setting for equipment in other refrigerant line is in progress.</li> <li>Outdoor automatic address setting is started while automatic address setting for indoor units is in progress.</li> </ul>																																																																																								
E15	—	E15	●	●	◎	Indoor unit not found during automatic address setting	Indoor unit fails to communicate while automatic address setting for indoor units is in progress.																																																																																								
E16	00: Capacity over 01: Number of units connected	E16	●	●	◎	Too many indoor units connected/capacity over	Combined capacity of indoor units is too large. The maximum combined of indoor units shown in the specification table.																																																																																								
E19	00: No header unit 02: Two or more header units	E19	●	●	◎	Trouble in number of outdoor header units	There is no or more than one outdoor header unit in one refrigerant line.																																																																																								
E20	01: Connection of outdoor unit from other refrigerant line 02: Connection of indoor unit from other refrigerant line	E20	●	●	◎	Connection to other refrigerant line found during automatic address setting	Indoor unit from other refrigerant line is detected while indoor automatic address setting is in progress.																																																																																								
E23	—	E23	●	●	◎	Outdoor-outdoor communication transmission trouble	Signal cannot be transmitted to other outdoor units.																																																																																								
E25	—	E25	●	●	◎	Duplicated follower outdoor address	There is duplication in outdoor addresses set manually.																																																																																								
E26	Address of outdoor unit from which signal is not received normally	E26	●	●	◎	Signal lack of outdoor unit	Follower outdoor unit initially communicating normally fails to do so (reduction in number of follower outdoor units connected).																																																																																								
E28	Detected outdoor unit No.	E28	●	●	◎	Outdoor follower unit trouble	Outdoor header unit detects trouble relating to follower outdoor unit (detail displayed on follower outdoor unit).																																																																																								
E31	<table border="1" style="font-size: small;"> <thead> <tr> <th colspan="4">P.C.board</th> <th colspan="4">P.C.board</th> </tr> <tr> <th colspan="2">Compressor</th> <th colspan="2">Fan Motor</th> <th colspan="2">Compressor</th> <th colspan="2">Fan Motor</th> </tr> <tr> <th>1</th><th>2</th><th>1</th><th>2</th><th>1</th><th>2</th><th>1</th><th>2</th> </tr> </thead> <tbody> <tr><td>01</td><td>○</td><td></td><td></td><td>11</td><td>○</td><td></td><td></td></tr> <tr><td>02</td><td>○</td><td>○</td><td></td><td>12</td><td>○</td><td>○</td><td></td></tr> <tr><td>03</td><td>○</td><td>○</td><td></td><td>13</td><td>○</td><td>○</td><td></td></tr> <tr><td>08</td><td></td><td></td><td>○</td><td>18</td><td></td><td></td><td>○</td></tr> <tr><td>09</td><td>○</td><td></td><td>○</td><td>19</td><td>○</td><td></td><td>○</td></tr> <tr><td>0A</td><td>○</td><td>○</td><td></td><td>1A</td><td>○</td><td></td><td>○</td></tr> <tr><td>0B</td><td>○</td><td>○</td><td></td><td>1B</td><td>○</td><td>○</td><td></td></tr> <tr><td>10</td><td></td><td></td><td>○</td><td></td><td></td><td></td><td>○</td></tr> </tbody> </table> <p>80 : Communication trouble between MCU and Sub MCU                      Circle (○): Trouble P.C. board</p>	P.C.board				P.C.board				Compressor		Fan Motor		Compressor		Fan Motor		1	2	1	2	1	2	1	2	01	○			11	○			02	○	○		12	○	○		03	○	○		13	○	○		08			○	18			○	09	○		○	19	○		○	0A	○	○		1A	○		○	0B	○	○		1B	○	○		10			○				○	E31	●	●	◎	P.C. board communication trouble Sub MCU communication trouble	There is no communication between P.C. boards in inverter box.
P.C.board				P.C.board																																																																																											
Compressor		Fan Motor		Compressor		Fan Motor																																																																																									
1	2	1	2	1	2	1	2																																																																																								
01	○			11	○																																																																																										
02	○	○		12	○	○																																																																																									
03	○	○		13	○	○																																																																																									
08			○	18			○																																																																																								
09	○		○	19	○		○																																																																																								
0A	○	○		1A	○		○																																																																																								
0B	○	○		1B	○	○																																																																																									
10			○				○																																																																																								
F04	—	F04	◎	◎	○	ALT	Outdoor discharge temperature sensor (TD1) trouble	Outdoor discharge temperature sensor (TD1) has been open/short-circuited.																																																																																							
F05	—	F05	◎	◎	○	ALT	Outdoor discharge temperature sensor (TD2) trouble	Outdoor discharge temperature sensor (TD2) has been open/short-circuited.																																																																																							
F06	01: TE1 sensor 02: TE2 sensor 03: TE3 sensor	F06	◎	◎	○	ALT	Outdoor heat exchanger liquid side temperature sensor (TE1, TE2, TE3) trouble	Outdoor heat exchanger liquid side temperature sensors (TE1, TE2, TE3) have been open/short-circuited.																																																																																							
F07	01: TL1 sensor 02: TL2 sensor 03: TL3 sensor	F07	◎	◎	○	ALT	Outdoor liquid temperature sensor (TL1, TL2, TL3) trouble	Outdoor liquid temperature sensor (TL1, TL2, TL3) has been open/short-circuited.																																																																																							
F08	—	F08	◎	◎	○	ALT	Outdoor outside air temperature sensor (TO) trouble	Outdoor air temperature sensor (TO) has been open/short-circuited.																																																																																							
F09	01: TG1 sensor 02: TG2 sensor 03: TG3 sensor	F09	◎	◎	○	ALT	Outdoor heat exchanger gas side temperature sensor (TG1, TG2, TG3) trouble	Outdoor heat exchanger gas side temperature sensors (TG1, TG2, TG3) have been open/short-circuited.																																																																																							

Check code		Display of receiving unit				Typical problem site	Description of problem	
Outdoor 7-segment display		Central control or main remote controller display	Indicator light block					
Sub-code			Operation 	Timer 	Ready 	Flash		
F12	01: TS1 sensor 03: TS3 sensor	F12	⊙	⊙	○	ALT	Outdoor suction temperature sensor (TS1,TS3) trouble	Outdoor suction temperature sensor (TS1,TS3) has been open/short-circuited.
F15	–	F15	⊙	⊙	○	ALT	Outdoor temperature sensor (TE1,TL1) wiring trouble	Wiring trouble in outdoor temperature sensors (TE1,TL1) has been detected.
F16	–	F16	⊙	⊙	○	ALT	Outdoor pressure sensor (Pd, Ps) wiring trouble	Wiring trouble in outdoor pressure sensors (Pd, Ps) has been detected.
F23	–	F23	⊙	⊙	○	ALT	Low pressure sensor (Ps) trouble	Output voltage of low pressure sensor (Ps) is zero.
F24	–	F24	⊙	⊙	○	ALT	High pressure sensor (Pd) trouble	Output voltage of high pressure sensor (Pd) is zero or provides abnormal readings when compressors have been turned off.
F31	–	F31	⊙	⊙	○	SIM	Outdoor EEPROM trouble	Outdoor EEPROM is failure (alarm and shutdown for header unit and continued operation for follower unit)
H05	–	H05	●	⊙	●		Outdoor discharge temperature sensor (TD1) wiring trouble	Wiring/installation trouble or detachment of outdoor discharge temperature sensor (TD1) has been detected.
H06	–	H06	●	⊙	●		Activation of low-pressure protection	Low pressure (Ps) sensor detects abnormally low operating pressure.
H07	–	H07	●	⊙	●		Low oil level protection	Temperature sensor for oil level detection (TK1,TK2) detects abnormally low oil level.
H08	01: TK1 sensor trouble 02: TK2 sensor trouble	H08	●	⊙	●		Trouble in temperature sensor for oil level detection (TK1,TK2)	Temperature sensor for oil level detection (TK1,TK2) has been open/short-circuited.
H15	–	H15	●	⊙	●		Outdoor discharge temperature sensor (TD2) wiring trouble	Wiring/installation trouble or detachment of outdoor discharge temperature sensor (TD2) has been detected.
H16	01: TK1 oil circuit trouble 02: TK2 oil circuit trouble	H16	●	⊙	●		Oil level detection circuit trouble	No temperature change is detected by temperature sensor for oil level detection (TK1,TK2) despite compressor having been started.
L04	–	L04	⊙	○	⊙	SIM	Duplicated outdoor refrigerant line address	Identical refrigerant line address has been assigned to outdoor units belonging to different refrigerant piping systems.
L06	Number of priority indoor units (check code L05 or L06 depending on individual unit)	L05	⊙	●	⊙	SIM	Duplicated priority indoor unit (as displayed on priority indoor unit)	More than one indoor unit have been set up as priority indoor unit.
		L06	⊙	●	⊙	SIM	Duplicated priority indoor unit (as displayed on indoor unit other than priority indoor unit)	More than one indoor unit have been set up as priority indoor unit.
L08	–	(L08)	⊙	●	⊙	SIM	Indoor group address not set	Address setting have not been performed for one or more indoor units (also detected at indoor end).
L10	–	L10	⊙	○	⊙	SIM	Outdoor capacity not set	Outdoor unit capacity has not been set (after P.C. board replacement).
L17	–	L17	⊙	○	⊙	SIM	Outdoor model incompatibility trouble	Old model outdoor unit has been connected.
L23	–	L23	⊙	○	⊙	SIM	SW setting mistake	
L28	–	L28	⊙	○	⊙	SIM	Too many outdoor units connected	More than five outdoor units have been connected.

Check code			Display of receiving unit				Typical problem site	Description of problem																																																																																									
Outdoor 7-segment display			Indicator light block																																																																																														
Sub-code	Central control or main remote controller display		Operation	Timer	Ready	Flash																																																																																											
	Compressor	Fan Motor	(1)	(2)	(3)																																																																																												
L29	<table border="1"> <thead> <tr> <th colspan="4">P.C.board</th> <th colspan="4">P.C.board</th> </tr> <tr> <th colspan="2">Compressor</th> <th colspan="2">Fan Motor</th> <th colspan="2">Compressor</th> <th colspan="2">Fan Motor</th> </tr> <tr> <th>1</th><th>2</th><th>1</th><th>2</th> <th>1</th><th>2</th><th>1</th><th>2</th> </tr> </thead> <tbody> <tr><td>01</td><td>○</td><td></td><td></td><td>11</td><td>○</td><td></td><td>○</td></tr> <tr><td>02</td><td>○</td><td>○</td><td></td><td>12</td><td></td><td>○</td><td>○</td></tr> <tr><td>03</td><td>○</td><td>○</td><td></td><td>13</td><td>○</td><td>○</td><td>○</td></tr> <tr><td>08</td><td></td><td></td><td>○</td><td>18</td><td></td><td></td><td>○</td></tr> <tr><td>09</td><td>○</td><td></td><td>○</td><td>19</td><td>○</td><td></td><td>○</td></tr> <tr><td>0A</td><td></td><td>○</td><td>○</td><td>1A</td><td></td><td>○</td><td>○</td></tr> <tr><td>0B</td><td>○</td><td>○</td><td>○</td><td>1B</td><td>○</td><td>○</td><td>○</td></tr> <tr><td>10</td><td></td><td></td><td>○</td><td></td><td></td><td></td><td></td></tr> </tbody> </table>		P.C.board				P.C.board				Compressor		Fan Motor		Compressor		Fan Motor		1	2	1	2	1	2	1	2	01	○			11	○		○	02	○	○		12		○	○	03	○	○		13	○	○	○	08			○	18			○	09	○		○	19	○		○	0A		○	○	1A		○	○	0B	○	○	○	1B	○	○	○	10			○					L29	◎	○	◎	SIM	Trouble in number of P.C. boards	There are insufficient number of P.C. board in inverter box.
	P.C.board				P.C.board																																																																																												
	Compressor		Fan Motor		Compressor		Fan Motor																																																																																										
	1	2	1	2	1	2	1	2																																																																																									
	01	○			11	○		○																																																																																									
	02	○	○		12		○	○																																																																																									
	03	○	○		13	○	○	○																																																																																									
	08			○	18			○																																																																																									
	09	○		○	19	○		○																																																																																									
	0A		○	○	1A		○	○																																																																																									
	0B	○	○	○	1B	○	○	○																																																																																									
10			○																																																																																														
00		L29	◎	○	◎	SIM	The number of P.C. board trouble	When there is much number of an inverter P.C. board to model setting of an interface P.C. board.																																																																																									
L30	Detected indoor unit No.	(L30)	◎	○	◎	SIM	Indoor external trouble input (interlock)	Indoor unit has been shut down for external trouble input in one refrigerant line (detected by indoor unit).																																																																																									
P03	–	P03	◎	●	◎	ALT	Outdoor discharge (TD1) temperature trouble	Outdoor discharge temperature sensor (TD1) has detected abnormally high temperature.																																																																																									
P05	00: Power detection trouble 01: Open phase 02: Power supply miswiring	P05	◎	●	◎	ALT	Power detection trouble /Open phase detection /Power supply miswiring detection	Open phase is detected when power is turned on. Inverter DC voltage is too high (overvoltage) or too low (undervoltage).																																																																																									
P07	1 : Compressor 1 heat sink trouble 2 : Compressor 2 heat sink trouble	P07	◎	●	◎	ALT	Heat sink overheating trouble	Temperature sensor built into IPM (TH) detects overheating.																																																																																									
	04: Heat sink dew condensation						Heat sink dew condensation trouble	Outdoor liquid temperature sensor (TL2) has detected abnormally low temperature.																																																																																									
P10	Indoor unit No. detected	(P10)	●	◎	◎	ALT	Indoor unit overflow	Indoor unit has been shutdown in one refrigerant line due to detection of overflow (detected by indoor unit).																																																																																									
P11	–	P11	●	◎	◎	ALT	Outdoor heat exchanger freeze trouble	Remaining frost on outdoor heat exchanger has been detected repeatedly.																																																																																									
P13	–	P13	●	◎	◎	ALT	Outdoor liquid backflow detection trouble	State of refrigerant cycle circuit indicates liquid backflow operation.																																																																																									
P15	01: TS condition 02: TD condition	P15	◎	●	◎	ALT	Gas leak detection	Outdoor suction temperature sensor (TS1) detects sustained and repeated high temperatures that exceed standard value.																																																																																									
P17	–	P17	◎	●	◎	ALT	Outdoor discharge (TD2) temperature trouble	Outdoor discharge temperature sensor (TD2) detects abnormally high temperature.																																																																																									
P19	Outdoor unit No. detected	P19	◎	●	◎	ALT	4-way valve reversing trouble	Abnormality in refrigerating cycle is detected during heating operation.																																																																																									
P20	–	P20	◎	●	◎	ALT	Activation of high-pressure protection	High pressure (Pd) sensor detects high pressure that exceeds standard value.																																																																																									

MG-CTT: Magnet contactor

(Check code detected by Inverter of Compressor featuring in outdoor unit - typical examples)

Check code		Display of receiving unit				Typical problem site	Description of proplem	
Outdoor 7-segment display		Central control or main remote controller display	Indicator light block					
Sub-code			Operation Ⓛ	Timer Ⓢ	Ready Ⓢ	Flash		
F13	1*: Compressor 1 2*: Compressor 2	F13	Ⓛ	Ⓢ	○	ALT	Trouble in temperature sensor built into indoor IPM (TH)	Temperature sensor built into indoor IPM (TH) has been open/short-circuited.
H01	1*: Compressor 1 2*: Compressor 2	H01	●	Ⓢ	●		Compressor breakdown	Inverter current (Idc) detection circuit detects overcurrent.
H02	1*: Compressor 1 2*: Compressor 2	H02	●	Ⓢ	●		Compressor trouble (lockup)	Compressor lockup is detected
H03	1*: Compressor 1 2*: Compressor 2	H03	●	Ⓢ	●		Current detection circuit trouble	Abnormal current is detected while inverter compressor is turned off.
P04	01: Compressor 1 02: Compressor 2	P04	Ⓛ	●	Ⓢ	ALT	Activation of high-pressure SW	High-pressure SW is activated.
P05	01: Compressor 1 side 02: Compressor 2 side	P05	Ⓛ	●	Ⓢ	ALT	Compressor Vdc trouble	Inverter DC voltage is too high (overvoltage) or too low (undervoltage).
P07	01: Compressor 1 side 02: Compressor 2 side	P07	Ⓛ	●	Ⓢ	ALT	Heat sink overheat trouble	Temperature sensor built into IPM (TH) detects overheating.
P11	–	P11	●	Ⓢ	Ⓢ	ALT	Outdoor heat exchanger freeze trouble	Remaining frost on outdoor heat exchanger has been detected repeatedly.
P22	1*: Fan P.C. board 1 2*: Fan P.C. board 2	P22	Ⓛ	●	Ⓢ	ALT	Outdoor fan P.C. board trouble	Outdoor fan P.C. board detects trouble.
P26	1*: Compressor 1 2*: Compressor 2	P26	Ⓛ	●	Ⓢ	ALT	Activation of IPM, compressor short-circuit protection	Short-circuit protection for compressor motor driver circuit components is activated (momentary overcurrent).
P29	1*: Compressor 1 2*: Compressor 2	P29	Ⓛ	●	Ⓢ	ALT	Compressor position detection circuit trouble	Compressor motor position detection trouble is detected.

Note: The above check codes are examples only, and different check codes may be displayed depending on the outdoor unit configuration

## 9-3. Troubleshooting based on information displayed on remote controller

### <RBC-AMT\*\*\*>

#### (1) Checking and testing

When a trouble occurs to an air conditioner, a check code and indoor unit No. are displayed on the display window of the remote controller. Check codes are only displayed while the air conditioner is in operation. If the display has already disappeared, access check code history by following the procedure described below.

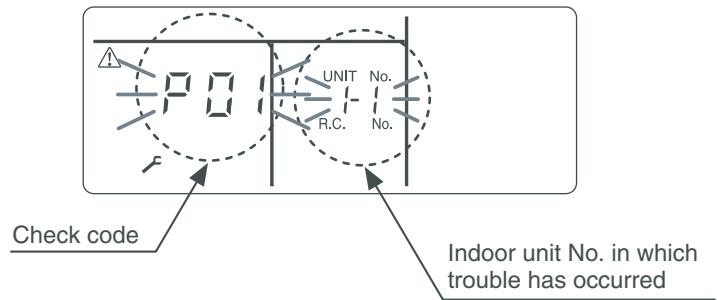

#### (2) Trouble history

The trouble history access procedure is described below (up to four check codes stored in memory). Check code history can be accessed regardless of whether the air conditioner is in operation or shut down.

<Procedure> To be performed when system at rest

### 1 Invoke the SERVICE CHECK mode by pressing the **TEST** + **SET** buttons simultaneously and holding for at least 4 seconds.

The letters "SERVICE CHECK" light up, and the check code "01" is displayed, indicating the trouble history. This is accompanied by the indoor unit No. to which the trouble history is related and a check code.

### 2 To check other trouble history items, press the **TEMP.** button to select another check code.

Check code "01" (latest) → Check code "04" (oldest)  
Note: Trouble history contains four items.

### 3 When the **TEST** button is pushed, normal display is restored.

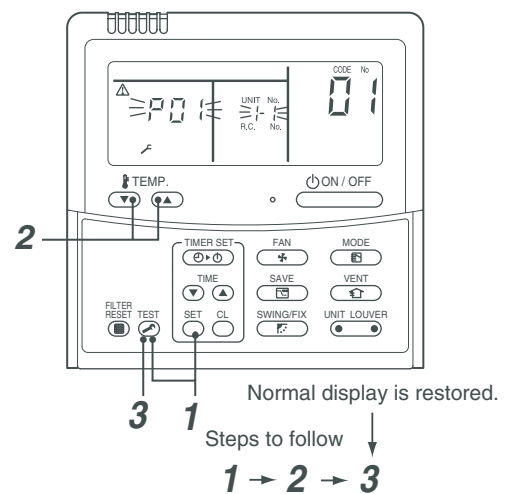

## CAUTION

Do not push the **TEST** button as it would erase the whole trouble history of the indoor unit.

<RBC-ASCU11-\*>

(1) Confirmation and check

If a problem occurs with the air conditioner, the OFF timer indicator alternately shows the check code and the indoor Unit No. in which the problem occurred.

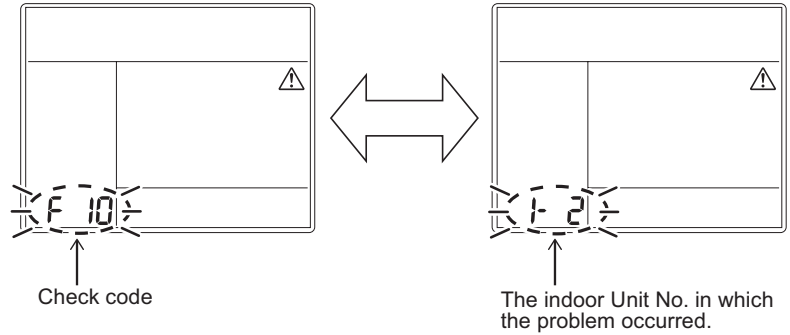

(2) Troubleshooting history and confirmation

You can check the troubleshooting history with the following procedure if a problem occurs with the air conditioner.

(The troubleshooting history records up to 4 incidents.)

You can check it during operation or when operation is stopped.

- If you check the troubleshooting history during OFF timer operation, the OFF timer will be canceled.

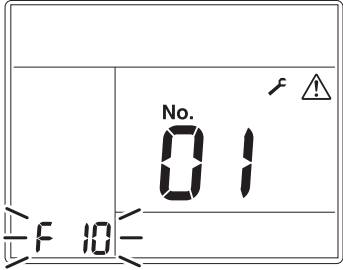
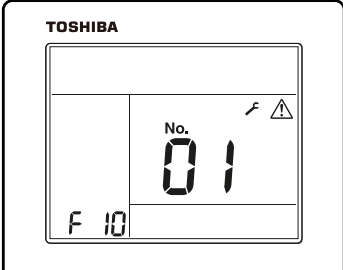
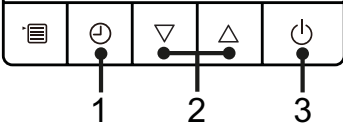
Procedure	Description of operation
<p><b>1</b></p>	<p>Push the OFF timer button for over 10 seconds and the indicators appear as an image indicating the troubleshooting history mode has been entered. If [  Service check] is displayed, the mode enters in the troubleshooting history mode.</p> <ul style="list-style-type: none"> <li>• [01: Order of troubleshooting history] appears in the temperature indicator.</li> <li>• The OFF timer indicator alternately shows the [check code] and the [indoor Unit No. ] in which the problem occurred.</li> </ul> 
<p><b>2</b></p>	<p>Each time the setting button is pushed, the recorded troubleshooting history is displayed in sequence. The troubleshooting history appears in order from [01] (newest) to [04] (oldest).</p> <p><b>CAUTION</b></p> <p>In the troubleshooting history mode, DO NOT push the Menu button for over 10 seconds, doing so deletes the entire troubleshooting history of the indoor unit.</p> 
<p><b>3</b></p>	<p>After you have finished checking, push the ON/OFF button to return to the regular mode.</p> <ul style="list-style-type: none"> <li>• If the air conditioner is operating, it remains operated even after the ON/OFF button has been pushed. To stop its operation, push the ON/OFF button again.</li> </ul> 

How to read displayed information

<7-segment display symbols>



<Corresponding alphanumerical letters>

0 1 2 3 4 5 6 7 8 9 A b C d E F H J L P

## Using indoor unit indicators (receiving unit light block) (wireless type)

To identify the check code, check the 7-segment display on the header unit. To check for check codes not displayed on the 7-segment display, consult the “List of Check Codes (Indoor Unit)” in “9-2. Troubleshooting method”.

● : Goes off ○ : Lighting ☉ : Blinking (0.5 seconds)

Light block	Check code	Cause of trouble	
Operation ●    Timer ●    Ready ● All lights out	–	Power turned off or trouble in wiring between receiving and indoor units	
Operation ☉    Timer ●    Ready ● Blinking	E01	Trouble reception	Receiving unit
	E02	Trouble transmission	
	E03	Loss of communication	
	E08	Duplicated indoor unit No. (address)	
	E09	Duplicated master remote controller	
	E10	Communication trouble between indoor unit MCU	
	E11	Communication trouble between Application control kit and indoor unit P.C. board	
	E12	Automatic address starting trouble	
	E18	Trouble or poor contact in wiring between indoor units, indoor power turned off	
Operation ●    Timer ●    Ready ☉ Blinking	E04	Trouble or poor contact in wiring between indoor and outdoor units (loss of indoor-outdoor communication)	
	E06	<ul style="list-style-type: none"> <li>• Trouble reception in indoor-outdoor communication (dropping out of indoor unit)</li> <li>• In TU2C-LINK communication system, if the termination resistance is not set in any of the indoor units</li> </ul>	
	E07	Trouble transmission in indoor-outdoor communication	
	E15	Indoor unit not found during automatic address setting	
	E16	Too many indoor units connected / overloading	
	E19	Trouble in number of outdoor header units	
	E20	Detection of refrigerant piping communication trouble during automatic address setting	
	E23	Trouble transmission in outdoor-outdoor communication	
	E25	Duplicated follower outdoor address	
	E26	Trouble reception in outdoor-outdoor communication, dropping out of outdoor unit	
	E28	Outdoor follower unit trouble	
	E31	P.C. board communication trouble	
	Operation ●    Timer ☉    Ready ☉ Alternate blinking	P01	Indoor AC fan trouble
P10		Indoor overflow trouble	
P11		Outdoor heat exchanger freezing trouble	
P12		Indoor DC fan trouble	
P13		Outdoor liquid backflow detection trouble	
Operation ☉    Timer ●    Ready ☉ Alternate blinking	P03	Outdoor discharge (TD1) temperature trouble	
	P04	Activation of outdoor high-pressure SW	
	P05	Open phase / power failure Inverter DC voltage (Vdc) trouble MG-CTT trouble	
	P07	Outdoor heat sink overheating trouble - Poor cooling of electrical component (IGBT) of outdoor unit	
	P15	Gas leak detection - insufficient refrigerant charging	
	P17	Outdoor discharge (TD2) temperature trouble	
	P18	Outdoor discharge (TD3) temperature trouble	
	P19	Outdoor 4-way valve reversing trouble	
	P20	Activation of high-pressure protection	
	P22	Outdoor fan P.C. board trouble	
	P26	Outdoor IPM, Compressor short-circuit trouble	
	P29	Compressor position detection circuit trouble	
	P31	Shutdown of other indoor unit in group due to trouble (group follower unit trouble)	

MG-CTT: Magnet contactor

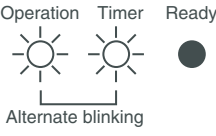
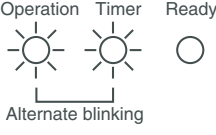
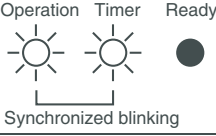
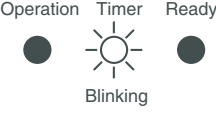
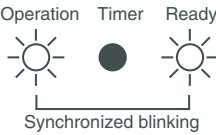
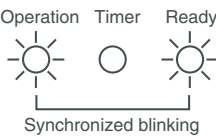

Light block	Check code	Cause of trouble		
Operation Timer Ready 	F01	Heat exchanger temperature sensor (TCJ) trouble	Indoor unit temperature sensor trouble	
	F02	Heat exchanger temperature sensor (TC2) trouble		
	F03	Heat exchanger temperature sensor (TC1) trouble		
	F10	Ambient temperature sensor (TA) trouble		
	F11	Discharge temperature sensor (TF) trouble		
Operation Timer Ready 	F04	Discharge temperature sensor (TD1) trouble	Outdoor unit temperature sensor trouble	
	F05	Discharge temperature sensor (TD2) trouble		
	F06	Heat exchanger temperature sensor (TE1, TE2) trouble		
	F07	Liquid temperature sensor (TL) trouble		
	F08	Outside air temperature sensor (TO) trouble		
	F09	TG1, TG2 or TG3 sensor trouble		
	F12	Suction temperature sensor (TS1) trouble		
	F13	Heat sink sensor (TH) trouble		
	F15	Wiring trouble in heat exchanger sensor (TE1) and liquid temperature sensor (TL) Outdoor unit temperature sensor wiring / installation trouble	Outdoor unit pressure sensor trouble	
	F16	Wiring trouble in outdoor high pressure sensor (Pd) and low pressure sensor (Ps) Outdoor pressure sensor wiring trouble		
	F22	Outdoor discharge temperature sensor (TD3) trouble		
	F23	Low pressure sensor (Ps) trouble		
	F24	High pressure sensor (Pd) trouble		
Operation Timer Ready 	F29	Failure in indoor EEPROM		
	Operation Timer Ready 	H01	Compressor breakdown	Outdoor unit compressor related trouble
		H02	Compressor lockup	
		H03	Current detection circuit trouble	
H04		Comp. 1 case thermostat operation	Protective shutdown of outdoor unit	
H05		Wiring / installation trouble or detachment of outdoor discharge temperature sensor (TD1)		
H06		Abnormal drop in low-pressure sensor (Ps) reading	Protective shutdown of outdoor unit	
H07		Abnormal drop in oil level		
H08		Trouble in temperature sensor for oil level detection circuit (TK1, TK2, TK3, TK4 or TK5)		
F14		Comp. 2 case thermostat operation		
H15		Wiring / installation trouble or detachment of outdoor discharge temperature sensor (TD2)		
H16		Oil level detection circuit trouble - Trouble in outdoor unit TK1, TK2, TK3, TK4 or TK5 circuit		
H25		Wiring / installation trouble or detachment of outdoor discharge temperature sensor (TD3)		
Operation Timer Ready 		L02	Model mismatched of indoor and outdoor unit	
		L03	Duplicated indoor group header unit	
	L05	Duplicated priority indoor unit (as displayed on priority indoor unit)		
	L06	Duplicated priority indoor unit (as displayed on indoor unit other than priority indoor unit)		
	L07	Connection of group control cable to a single indoor unit		
	L08	Indoor group address not set		
	L09	Indoor capacity not set		
	Operation Timer Ready 	L04	Duplicated outdoor refrigerant line address	
		L10	Outdoor capacity not set	
L17		Outdoor model incompatibility trouble		
L18		Flow selector units trouble		
L20		Duplicated central control address		
L28		Too many outdoor units connected		
L29		Trouble in number of P.C. boards		
L30		Indoor external interlock trouble (External abnormal input)		

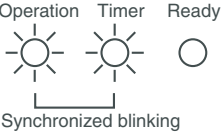
Light block	Check code	Cause of trouble
Operation    Timer    Ready 	F30	Occupancy sensor trouble
	F31	Outdoor EEPROM trouble

### Other (indications not involving check code)

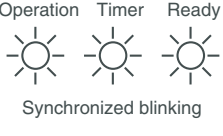
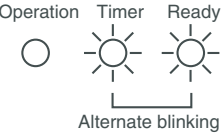
Light block	Check code	Cause of trouble
Operation    Timer    Ready 	–	Test run in progress
Operation    Timer    Ready 	–	Setting incompatibility (automatic cooling / heating setting for model incapable of it and heating setting for cooling-only model)

### Flow selector unit (FS unit) Relation

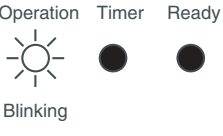
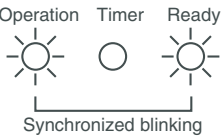
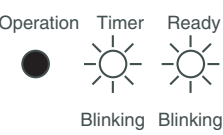
Light block	Check code	Cause of trouble
Operation    Timer    Ready 	E17	Communication trouble between indoor unit(s) and FS unit(s)
Operation    Timer    Ready 	L12	FS unit(s) system trouble
	L24	FS unit(s) setting trouble
Operation    Timer    Ready 	J03	Duplicated FS units
	J10	FS unit overflow trouble
	J11	FS unit temperature sensor(TCS) trouble

## 9-4. Check Codes Displayed on Remote Controller and SMMS series Outdoor Unit (7-Segment Display on I/F Board) and Locations to Be Checked

For other types of outdoor units, refer to their own service manuals.

Main remote controller	Check code		Location of detection	Description	System status	Check code detection condition(s)	Check items (locations)
	Outdoor 7-segment display	Sub-code					
	Check code						
E01	—	—	Remote controller	Indoor-remote controller communication trouble (detected at remote controller end)	Stop of corresponding unit	Communication between indoor P.C. board and remote controller is disrupted.	<ul style="list-style-type: none"> <li>• Check remote controller inter-unit tie cable (A/B).</li> <li>• Check for broken wire or connector bad contact.</li> <li>• Check indoor power supply.</li> <li>• Check for failure in indoor P.C. board.</li> <li>• Check remote controller address settings (when two remote controllers are in use).</li> <li>• Check remote controller P.C. board.</li> </ul>
E02	—	—	Remote controller	Remote controller transmission trouble	Stop of corresponding unit	Signal cannot be transmitted from remote controller to indoor unit.	<ul style="list-style-type: none"> <li>• Check internal transmission circuit of remote controller.</li> <li>--- Replace remote controller as necessary.</li> </ul>
E03	—	—	Indoor unit	Indoor-remote controller communication trouble (detected at indoor end)	Stop of corresponding unit	There is no communication from remote controller (including wireless) or network adaptor.	<ul style="list-style-type: none"> <li>• Check remote controller and network adaptor wiring.</li> </ul>
E04	—	—	Indoor unit	Indoor-outdoor communication circuit trouble (detected at indoor end)	Stop of corresponding unit	Indoor unit is not receiving signal from outdoor unit.	<ul style="list-style-type: none"> <li>• Check order in which power was turned on for indoor and outdoor units.</li> <li>• Check indoor address setting.</li> <li>• Check indoor-outdoor tie cable.</li> <li>• Check outdoor terminator resistor setting (SW100, Bit 2).</li> </ul>
E04	E06	No. of indoor units from which signal is received normally	I/F	Dropping out of indoor unit	All stop	<p><b>Condition 1</b> All indoor unit initially communicating normally fails to return signal for specified length of time.</p> <p><b>Condition 2</b> Outdoor I / F board SW103, Bit4 : OFF (Factory default)</p>	<ul style="list-style-type: none"> <li>• Check power supply to indoor unit. (Is power turned on?)</li> <li>• Check connection of indoor-outdoor communication cable.</li> <li>• Check connection of communication connectors on indoor P.C. board.</li> <li>• Check connection of communication connectors on outdoor P.C. board.</li> <li>• Check for failure in indoor P.C. board.</li> <li>• Check for failure in outdoor P.C. board (I/F).</li> </ul>
	—	—	Indoor unit	Indoor-outdoor communication circuit trouble	Only specified indoor units stop	<p><b>Condition 1</b> Indoor unit initially communicating normally fails to return signal for specified length of time.</p>	<ul style="list-style-type: none"> <li>• Check power supply to indoor unit. (Is power turned on?)</li> <li>• Check indoor-outdoor power-on sequence.</li> <li>• Check indoor address setting</li> <li>• Check wiring of Indoor-outdoor communication wires</li> <li>• Check outdoor terminator resistor setting (SW100, Bit 2).</li> </ul>

Check code			Location of detection	Description	System status	Check code detection condition(s)	Check items (locations)
Main remote controller	Outdoor 7-segment display						
	Check code	Sub-code					
E04/E06	E06	No. of indoor units from which signal is received normally	Indoor unit	Indoor-outdoor communication circuit trouble (E04)	All stop	<p><b>Condition 1</b> One indoor unit or more initially communicating normally fails to return signal for specified length of time.</p> <p><b>Condition 2</b> Outdoor I / F board SW103, Bit4 : ON (To switch the check code detection condition.)</p>  <p>SW103</p>	<ul style="list-style-type: none"> <li>• Check power supply to indoor unit. (Is power turned on?)</li> <li>• Check indoor-outdoor power-on sequence.</li> <li>• Check indoor address setting</li> <li>• Check wiring of Indoor-outdoor communication wires</li> <li>• Check outdoor terminator resistor setting (SW100, Bit 2).</li> </ul>
			I/F	Dropping out of indoor unit (E06)			
—	E07	—	I/F	Indoor-outdoor communication circuit trouble (detected at outdoor end)	All stop	Signal cannot be transmitted from outdoor to indoor units for 30 seconds continuously.	<ul style="list-style-type: none"> <li>• Check outdoor terminator resistor setting (SW100, Bit 2).</li> <li>• Check connection of indoor-outdoor communication circuit.</li> </ul>
E08	E08	Duplicated indoor address	Indoor unit I/F	Duplicated indoor address	All stop	More than one indoor unit are assigned same address.	<ul style="list-style-type: none"> <li>• Check indoor addresses.</li> <li>• Check for any change made to remote controller connection (group/ individual) since indoor address setting.</li> </ul>
E09	—	—	Remote controller	Duplicated master remote controller	Stop of corresponding unit	In two remote controller configuration (including wireless), both controllers are set up as master. (Header indoor unit is shut down with alarm, while follower indoor units continue operating.)	<ul style="list-style-type: none"> <li>• Check remote controller settings.</li> <li>• Check remote controller P.C. boards.</li> </ul>
E10	—	—	Indoor unit	Indoor inter-MCU communication trouble	Stop of corresponding unit	Communication cannot be established/maintained upon turning on of power or during communication.	<ul style="list-style-type: none"> <li>• Check for failure in indoor P.C. board</li> </ul>
E12	E12	01: Indoor-outdoor communication 02: Outdoor-outdoor communication	I/F	Automatic address starting trouble	All stop	<ul style="list-style-type: none"> <li>• Indoor automatic address setting is started while automatic address setting for equipment in other refrigerant line is in progress.</li> <li>• Outdoor automatic address setting is started while automatic address setting for indoor units is in progress.</li> </ul>	<ul style="list-style-type: none"> <li>• Check whether the outdoor unit of other systems or the indoor unit is connected to Uv (U1/U2) line or Uc (U5/U6) line.</li> <li>• Perform automatic address setting again after disconnecting communication cable to that refrigerant line.</li> </ul>
E15	E15	—	I/F	Indoor unit not found during automatic address setting	All stop	Indoor unit cannot be detected after indoor automatic address setting is started.	<ul style="list-style-type: none"> <li>• Check connection of indoor-outdoor communication line.</li> <li>• Check for trouble in indoor power supply system.</li> <li>• Check for noise from other devices.</li> <li>• Check for power failure.</li> <li>• Check for failure in indoor P.C. board.</li> </ul>

Main remote controller	Check code		Location of detection	Description	System status	Check code detection condition(s)	Check items (locations)
	Outdoor 7-segment display						
	Check code	Sub-code					
E16	E16	00: Capacity over 01-: No. of units connected	I/F	Too many indoor units connected	All stop	<ul style="list-style-type: none"> <li>Combined capacity of indoor units is too large.</li> </ul> <p><b>Note:</b> If this code comes up after backup setting for outdoor unit failure is performed, perform "No capacity over detected" setting.</p> <p>&lt;"No capacity over detected" setting method&gt; Turn on SW103 / Bit 3 on I/F P.C. board of outdoor header unit. For Cooling Only model, this check code is not displayed even if it exceeds the combined capacity of indoor units.</p> <ul style="list-style-type: none"> <li>More than 128 indoor units are connected.</li> </ul>	<ul style="list-style-type: none"> <li>Check capacities of indoor units connected.</li> <li>Check combined HP capacities of indoor units.</li> <li>Check HP capacity settings of outdoor units.</li> <li>Check No. of indoor units connected.</li> <li>Check for failure in outdoor P.C. board (I/F).</li> </ul>
E18	—	—	Indoor unit	Trouble in communication between indoor header and follower units	Stop of corresponding unit	<p>Periodic communication between indoor header and follower units cannot be maintained.</p>	<ul style="list-style-type: none"> <li>Check remote controller wiring.</li> <li>Check indoor power supply wiring.</li> <li>Check P.C. boards of indoor units.</li> </ul>
E19	E19	00: No header unit 02: Two or more header units	I/F	Trouble in number of outdoor header units	All stop	<ul style="list-style-type: none"> <li>There are more than one outdoor header units in one line.</li> <li>There is no outdoor header unit in one line.</li> </ul>	<p>The outdoor unit which turned on SW101 and the bit 1 of the interface P.C. board is set to Header unit.</p> <ul style="list-style-type: none"> <li>Check SW101 bit 1 of follower outdoor unit.</li> <li>Check connection of indoor-outdoor communication line.</li> <li>Check for failure in outdoor P.C. board (I/F).</li> </ul>
E20	E20	01: Connection of outdoor unit from other line 02: Connection of indoor unit from other line	I/F	Connection to other line found during automatic address setting	All stop	<p>Equipment from other line is found to have been connected when indoor automatic address setting is in progress.</p>	<p>Check whether the outdoor unit of other systems or the indoor unit is connected to Uv (U1/U2) line or Uc (U5/U6) line.</p>
E23	E23	—	I/F	Outdoor/outdoor communication transmission trouble	All stop	<p>Signal cannot be transmitted to other outdoor units for at least 30 seconds continuously.</p>	<ul style="list-style-type: none"> <li>Check power supply to outdoor units. (Is power turned on?)</li> <li>Check connection of tie cables between outdoor units for bad contact or broken wire.</li> <li>Check communication connectors on outdoor P.C. boards.</li> <li>Check for failure in outdoor P.C. board (I/F).</li> <li>Check termination resistance setting for communication between outdoor units.</li> </ul>
E25	E25	—	I/F	Duplicated follower outdoor address	All stop	<p>There is duplication in outdoor addresses set manually.</p>	<p><b>Note:</b> Do not set outdoor addresses manually.</p>
E26	E26	Address of outdoor unit from which signal is not received normally	I/F	Signal lack of outdoor unit	All stop	<p>Outdoor unit initially communicating normally fails to return signal for specified length of time.</p>	<ul style="list-style-type: none"> <li>Backup setting is being used for outdoor units.</li> <li>Check power supply to outdoor unit. (Is power turned on?)</li> <li>Check connection of tie cables between outdoor units for bad contact or broken wire.</li> <li>Check communication connectors on outdoor P.C. boards.</li> <li>Check for failure in outdoor P.C. board (I/F).</li> </ul>

Check code			Location of detection	Description	System status	Check code detection condition(s)	Check items (locations)																																																																								
Main remote controller	Outdoor 7-segment display																																																																														
	Check code	Sub-code																																																																													
The check code which occurred follower outdoor unit is displayed	E28	Detected outdoor unit No.	I/F	Outdoor follower unit trouble	All stop	Outdoor header unit receives trouble code from outdoor follower unit.	<ul style="list-style-type: none"> <li>Check check code displayed on outdoor follower unit.</li> </ul> <Convenient functions> If SW04 is pressed and held for at least 1 second while [E28] is displayed on the 7-segment display of outdoor header unit, the fan of the outdoor unit that has been shut down due to a trouble comes on. If SW04 and SW05 are pressed simultaneously, the fans of normal outdoor units come on. To stop the fan or fans, press SW05 on its own.																																																																								
E31	E31	<table border="1"> <thead> <tr> <th colspan="4">P.C. board</th> </tr> <tr> <th colspan="2">Compressor</th> <th colspan="2">Fan Motor</th> </tr> <tr> <th>1</th> <th>2</th> <th>1</th> <th>2</th> </tr> </thead> <tbody> <tr><td>01</td><td>○</td><td></td><td></td></tr> <tr><td>02</td><td></td><td>○</td><td></td></tr> <tr><td>03</td><td>○</td><td>○</td><td></td></tr> <tr><td>08</td><td></td><td></td><td>○</td></tr> <tr><td>09</td><td>○</td><td></td><td>○</td></tr> <tr><td>0A</td><td></td><td>○</td><td>○</td></tr> <tr><td>0B</td><td>○</td><td>○</td><td>○</td></tr> <tr><td>10</td><td></td><td></td><td>○</td></tr> <tr><td>11</td><td>○</td><td></td><td>○</td></tr> <tr><td>12</td><td></td><td>○</td><td>○</td></tr> <tr><td>13</td><td>○</td><td>○</td><td>○</td></tr> <tr><td>18</td><td></td><td></td><td>○</td></tr> <tr><td>19</td><td>○</td><td></td><td>○</td></tr> <tr><td>1A</td><td></td><td>○</td><td>○</td></tr> <tr><td>1B</td><td>○</td><td>○</td><td>○</td></tr> </tbody> </table> Circle (O): Trouble P.C. board	P.C. board				Compressor		Fan Motor		1	2	1	2	01	○			02		○		03	○	○		08			○	09	○		○	0A		○	○	0B	○	○	○	10			○	11	○		○	12		○	○	13	○	○	○	18			○	19	○		○	1A		○	○	1B	○	○	○	I/F	P.C. board communication trouble	All stop	Communication is disrupted between P.C. board in inverter box.	<ul style="list-style-type: none"> <li>Check wiring and connectors involved in communication between P.C. board I/F P.C. board for bad contact or broken wire.</li> <li>Check for failure in outdoor P.C. board (I/F, comp. P.C. board or Fan P.C. board).</li> <li>Check for external noise.</li> </ul>
		P.C. board																																																																													
Compressor		Fan Motor																																																																													
1	2	1	2																																																																												
01	○																																																																														
02		○																																																																													
03	○	○																																																																													
08			○																																																																												
09	○		○																																																																												
0A		○	○																																																																												
0B	○	○	○																																																																												
10			○																																																																												
11	○		○																																																																												
12		○	○																																																																												
13	○	○	○																																																																												
18			○																																																																												
19	○		○																																																																												
1A		○	○																																																																												
1B	○	○	○																																																																												
		80		Communication trouble between MCU and Sub MCU	All stop	Communication between MCU and Sub MCU stopped.	<ul style="list-style-type: none"> <li>Operation of power supply reset (OFF for 60 seconds or more)</li> <li>Outdoor I/F PC board trouble check</li> </ul>																																																																								
F01	—	—	Indoor unit	Indoor TCJ sensor trouble	Stop of corresponding unit	Sensor resistance is infinity or zero (open/short circuit).	<ul style="list-style-type: none"> <li>Check connection of TCJ sensor connector and wiring.</li> <li>Check resistance characteristics of TCJ sensor.</li> <li>Check for failure in indoor P.C. board.</li> </ul>																																																																								
F02	—	—	Indoor unit	Indoor TC2 sensor trouble	Stop of corresponding unit	Sensor resistance is infinity or zero (open/short circuit).	<ul style="list-style-type: none"> <li>Check connection of TC2 sensor connector and wiring.</li> <li>Check resistance characteristics of TC2 sensor.</li> <li>Check for failure in indoor P.C. board.</li> </ul>																																																																								
F03	—	—	Indoor unit	Indoor TC1 sensor trouble	Stop of corresponding unit	Sensor resistance is infinity or zero (open/short circuit).	<ul style="list-style-type: none"> <li>Check connection of TC1 sensor connector and wiring.</li> <li>Check resistance characteristics of TC1 sensor.</li> <li>Check for failure in indoor P.C. board.</li> </ul>																																																																								
F04	F04	—	I/F	TD1 sensor trouble	All stop	Sensor resistance is infinity or zero (open/short circuit).	<ul style="list-style-type: none"> <li>Check connection of TD1 sensor connector.</li> <li>Check resistance characteristics of TD1 sensor.</li> <li>Check for failure in outdoor P.C. board (I/F).</li> </ul>																																																																								

Main remote controller	Check code		Location of detection	Description	System status	Check code detection condition(s)	Check items (locations)
	Outdoor 7-segment display						
	Check code	Sub-code					
F05	F05	—	I/F	TD2 sensor trouble	All stop	Sensor resistance is infinity or zero (open/short circuit).	<ul style="list-style-type: none"> <li>• Check connection of TD2 sensor connector.</li> <li>• Check resistance characteristics of TD2 sensor.</li> <li>• Check for failure in outdoor P.C. board (I/F).</li> </ul>
F06	F06	01: TE1 sensor trouble 02: TE2 sensor trouble 03: TE3 sensor trouble	I/F	TE1/TE2/TE3 sensor trouble	All stop	Sensor resistance is infinity or zero (open/short circuit).	<ul style="list-style-type: none"> <li>• Check connection of TE1/TE2/TE3 sensor connectors.</li> <li>• Check resistance characteristics of TE1/TE2/TE3 sensors.</li> <li>• Check for failure in outdoor P.C. board (I/F).</li> </ul>
F07	F07	01: TL1 sensor trouble 02: TL2 sensor trouble 03: TL3 sensor trouble	I/F	TL1/TL2/TL3 sensor trouble	All stop	Sensor resistance is infinity or zero (open/short circuit).	<ul style="list-style-type: none"> <li>• Check connection of TL1/TL2/TL3 sensor connector.</li> <li>• Check resistance characteristics of TL1/TL2/TL3 sensor.</li> <li>• Check for failure in outdoor P.C. board (I/F).</li> </ul>
F08	F08	—	I/F	TO sensor trouble	All stop	Sensor resistance is infinity or zero (open/short circuit).	<ul style="list-style-type: none"> <li>• Check connection of TO sensor connector.</li> <li>• Check resistance characteristics of TO sensor.</li> <li>• Check for failure in outdoor P.C. board (I/F).</li> </ul>
F09	F09	01: TG1 sensor trouble 02: TG2 sensor trouble 03: TG3 sensor trouble	I/F	TG1/TG2/TG3 sensor trouble	All stop	Sensor resistance is infinity or zero (open/short circuit).	<ul style="list-style-type: none"> <li>• Check connection of TG1/TG2/TG3 sensor connectors.</li> <li>• Check resistance characteristics of TG1/TG2/TG3 sensors.</li> <li>• Check for failure in outdoor P.C. board (I/F).</li> </ul>
F10	—	—	Indoor unit	Indoor TA sensor trouble	Stop of corresponding unit	Sensor resistance is infinity or zero (open/short circuit).	<ul style="list-style-type: none"> <li>• Check connection of TA sensor connector and wiring.</li> <li>• Check resistance characteristics of TA sensor.</li> <li>• Check for failure in indoor P.C. board.</li> </ul>
F11	—	—	Indoor unit	Indoor TF sensor trouble	Stop of corresponding unit	Sensor resistance is infinity or zero (open/short circuit).	<ul style="list-style-type: none"> <li>• Check connection of TF sensor connector and wiring.</li> <li>• Check resistance characteristics of TF sensor.</li> <li>• Check for failure in indoor P.C. board.</li> </ul>
F12	F12	01: TS1 sensor trouble 03: TS3 sensor trouble	I/F	TS1/TS3 sensor trouble	All stop	Sensor resistance is infinity or zero (open/short circuit).	<ul style="list-style-type: none"> <li>• Check connection of TS1/TS3 sensor connector</li> <li>• Check resistance characteristics of TS1/TS3 sensor.</li> <li>• Check for failure in indoor P.C. board.</li> </ul>
F13	F13	1*: Compressor 1 side 2*: Compressor 2 side	Compressor P.C. board	TH sensor trouble	All stop	Sensor resistance is infinity or zero (open/short circuit).	<ul style="list-style-type: none"> <li>• Failure in IPM built-in temperature sensor → Replace Compressor P.C. board.</li> </ul>
F15	F15	—	I/F	Outdoor temperature sensor wiring trouble (TE1, TL1)	All stop	During compressor operation in HEAT mode, TL1 continuously provides temperature reading higher than indicated by TL1 by at least specified margin for 3 minutes or more.	<ul style="list-style-type: none"> <li>• Check installation of TE1 and TL1 sensors.</li> <li>• Check resistance characteristics of TE1 and TL1 sensors.</li> <li>• Check for outdoor P.C. board (I/F) trouble</li> </ul>

Main remote controller	Check code		Location of detection	Description	System status	Check code detection condition(s)	Check items (locations)
	Outdoor 7-segment display						
	Check code	Sub-code					
F16	F16	—	I/F	Outdoor pressure sensor wiring trouble (Pd, Ps)	All stop	Readings of high-pressure Pd sensor and low-pressure Ps sensor are switched. Output voltages of both sensors are zero.	<ul style="list-style-type: none"> <li>• Check connection of high-pressure Pd sensor connector.</li> <li>• Check connection of low-pressure Ps sensor connector.</li> <li>• Check for failure in pressure sensors Pd and Ps.</li> <li>• Check for trouble in outdoor P.C. board (I/F).</li> <li>• Check for compressor poor compression.</li> </ul>
F23	F23	—	I/F	Ps sensor trouble	All stop	Output voltage of Ps sensor is zero.	<ul style="list-style-type: none"> <li>• Check for connection trouble involving Ps sensor and Pd sensor connectors.</li> <li>• Check connection of Ps sensor connector.</li> <li>• Check for failure in Ps sensor.</li> <li>• Check for compressor poor compression.</li> <li>• Check for failure in 4-way valve.</li> <li>• Check for failure in outdoor P.C. board (I/F).</li> <li>• Check for failure in SV4 circuit.</li> </ul>
F24	F24	—	I/F	Pd sensor trouble	All stop	Output voltage of Pd sensor is zero (sensor open-circuited). Pd > 4.15MPa despite compressor having been turned off.	<ul style="list-style-type: none"> <li>• Check connection of Pd sensor connector.</li> <li>• Check for failure in Pd sensor.</li> <li>• Check for failure in outdoor P.C. board (I/F).</li> </ul>
F29	—	—	Indoor unit	Other indoor trouble	Stop of corresponding unit	Indoor P.C. board does not operate normally.	<ul style="list-style-type: none"> <li>• Check for failure in indoor P.C. board (failure EEPROM)</li> </ul>
F31	F31	—	I/F	Outdoor EEPROM trouble	All stop *1	Outdoor P.C. board (I/F) does not operate normally.	<ul style="list-style-type: none"> <li>• Check power supply voltage.</li> <li>• Check power supply noise.</li> <li>• Check for failure in outdoor P.C. board (I/F).</li> </ul>
H01	H01	1*: Compressor 1 side 2*: Compressor 2 side	Compressor P.C. board	Compressor breakdown	All stop	Inverter current detection circuit detects overcurrent and shuts system down.	<ul style="list-style-type: none"> <li>• Check power supply voltage. (AC380V-415V ± 10%).</li> <li>• Check for failure in compressor.</li> <li>• Check for possible cause of abnormal overloading.</li> <li>• Check for failure in outdoor P.C. board (Compressor).</li> </ul>
H02	H02	1*: Compressor 1 side 2*: Compressor 2 side	Compressor P.C. board	Compressor trouble (lockup) MG-CTT trouble	All stop	Overcurrent is detected several seconds after startup of inverter compressor.	<ul style="list-style-type: none"> <li>• Check for failure in compressor.</li> <li>• Check power supply voltage. (AC380V-415V ± 10%).</li> <li>• Check compressor system wiring, particularly for open phase.</li> <li>• Check connection of connectors/terminals on compressor P.C. board.</li> <li>• Check conductivity of case heater. (Check for refrigerant problem inside compressor.)</li> <li>• Check for failure in outdoor P.C. board (Compressor).</li> <li>• Check outdoor MG-CTT.</li> </ul>
H03	H03	1*: Compressor 1 side 2*: Compressor 2 side	Compressor P.C. board	Current detection circuit trouble	All stop	Current flow of at least specified magnitude is detected despite inverter compressor having been shut turned off.	<ul style="list-style-type: none"> <li>• Check current detection circuit wiring.</li> <li>• Check failure in outdoor P.C. board (Compressor).</li> </ul>

\*1 Total shutdown in case of header unit  
Continued operation in case of follower unit



Main remote controller	Check code		Location of detection	Description	System status	Check code detection condition(s)	Check items (locations)
	Outdoor 7-segment display						
	Check code	Sub-code					
H05	H05	—	I/F	TD1 sensor miswiring (incomplete insertion)	All stop	Discharge temperature of compressor 1 (TD1) does not increase despite compressor being in operation.	<ul style="list-style-type: none"> <li>• Check installation of TD1 sensor.</li> <li>• Check connection of TD1 sensor connector and wiring.</li> <li>• Check resistance characteristics of TD1 sensor.</li> <li>• Check for failure in outdoor P.C. board (I/F).</li> </ul>
H06	H06	—	I/F	Activation of low-pressure protection	All stop	Low-pressure Ps sensor detects operating pressure lower than 0.02MPa.	<ul style="list-style-type: none"> <li>• Check service valves to confirm full opening (both gas and liquid sides).</li> <li>• Check outdoor PMVs for clogging (PMV1, 2, 3).</li> <li>• Check for failure in SV4 circuits.</li> <li>• Check for failure in low-pressure Ps sensor.</li> <li>• Check indoor filter for clogging.</li> <li>• Check valve opening status of indoor PMV.</li> <li>• Check refrigerant piping for clogging.</li> <li>• Check operation of outdoor fan (during heating).</li> <li>• Check for insufficiency in refrigerant quantity.</li> </ul>
H07	H07	—	I/F	Low oil level protection	All stop	Operating compressor detects continuous state of low oil level for about 2 hours.	<p>&lt;All outdoor units in corresponding line to be checked&gt;</p> <ul style="list-style-type: none"> <li>• Check connection and installation of TK1 and TK2 sensors.</li> <li>• Check resistance characteristics of TK1 and TK2 sensors.</li> <li>• Check for gas or oil leak in same line.</li> <li>• Check for refrigerant problem inside compressor casing.</li> <li>• Check SV3D, SV3F valves for failure.</li> <li>• Check oil return circuit of oil separator for clogging.</li> <li>• Check oil equalizing circuit for clogging.</li> </ul>
H08	H08	01: TK1 sensor trouble 02: TK2 sensor trouble	I/F	Trouble in temperature sensor for oil level detection	All stop	Sensor resistance is infinity or zero (open/short circuit).	<ul style="list-style-type: none"> <li>• Check connection of TK1 sensor connector.</li> <li>• Check resistance characteristics of TK1 sensor.</li> <li>• Check for failure in outdoor P.C. board (I/F).</li> </ul>
					All stop	Sensor resistance is infinity or zero (open/short circuit).	<ul style="list-style-type: none"> <li>• Check connection of TK2 sensor connector.</li> <li>• Check resistance characteristics of TK2 sensor.</li> <li>• Check for failure in outdoor P.C. board (I/F).</li> </ul>
H15	H15	—	I/F	TD2 sensor miswiring (incomplete insertion)	All stop	Discharge temperature of (TD2) does not increase despite compressor 2 being in operation.	<ul style="list-style-type: none"> <li>• Check installation of TD2 sensor.</li> <li>• Check connection of TD2 sensor connector and wiring.</li> <li>• Check resistance characteristics of TD2 sensor.</li> <li>• Check for failure in outdoor P.C. board (I/F).</li> </ul>

Main remote controller	Check code		Location of detection	Description	System status	Check code detection condition(s)	Check items (locations)
	Outdoor 7-segment display						
	Check code	Sub-code					
H16	H16	01: TK1 oil circuit trouble 02: TK2 oil circuit trouble	I/F	Oil level detection circuit trouble	All stop	No temperature change is detected by TK1 despite compressor 1 having been started.	<ul style="list-style-type: none"> <li>• Check for disconnection of TK1 sensor.</li> <li>• Check resistance characteristics of TK1 sensor.</li> <li>• Check for connection trouble involving TK1 and TK2 sensors</li> <li>• Check for clogging in oil equalizing circuit capillary.</li> <li>• Check for refrigerant entrapment inside compressor.</li> </ul>
						No temperature change is detected by TK2 despite compressor 2 having been started.	<ul style="list-style-type: none"> <li>• Check for disconnection of TK2 sensor.</li> <li>• Check resistance characteristics of TK2 sensor.</li> <li>• Check for connection trouble involving TK1 and TK2 sensors</li> <li>• Check SV3F valve malfunction.</li> <li>• Check for clogging in oil equalizing circuit capillary.</li> <li>• Check for refrigerant entrapment inside compressor.</li> </ul>
H17	H17	1*: Compressor 1 side 2*: Compressor 2 side	Compressor P.C. board	Compressor trouble (Step-out)	All stop	Judged that the synchronization could not be taken.	<ul style="list-style-type: none"> <li>• Check power supply voltage. (AC380V-415V ± 10%).</li> <li>• Check for failure in compressor.</li> <li>• Check for possible cause of abnormal overloading.</li> <li>• Check for failure in outdoor P.C. board (compressor).</li> </ul>
L02	L02	—	Indoor unit	Outdoor units model disagreement trouble	Stop of corresponding unit	In case of different outdoor unit (Not corresponded to Air to Air Heat Exchanger type)	<ul style="list-style-type: none"> <li>• Check outdoor unit model. (Check whether the outdoor unit corresponds to Air to Air Heat Exchanger type or not.)</li> </ul>
L03	—	—	Indoor unit	Duplicated indoor header unit	Stop of corresponding unit	There are more than one header units in group.	<ul style="list-style-type: none"> <li>• Check indoor addresses.</li> <li>• Check for any change made to remote controller connection (group/ individual) since indoor address setting.</li> </ul>
L04	L04	—	I/F	Duplicated outdoor line address	All stop	There is duplication in line address setting for outdoor units belonging to different refrigerant piping systems.	<ul style="list-style-type: none"> <li>• Check line addresses.</li> </ul>
L05	—	—	I/F	Duplicated priority indoor unit (as displayed on priority indoor unit)	All stop	More than one indoor units have been set up as priority indoor unit.	<ul style="list-style-type: none"> <li>• Check display on priority indoor unit.</li> </ul>
L06	L06	No. of priority indoor units	I/F	Duplicated priority indoor unit (as displayed on indoor unit other than priority indoor unit)	All stop	More than one indoor units have been set up as priority indoor unit.	<ul style="list-style-type: none"> <li>• Check displays on priority indoor unit and outdoor unit.</li> </ul>
L07	—	—	Indoor unit	Connection of group control cable to standalone indoor unit	Stop of corresponding unit	There is at least one standalone indoor unit to which group control cable is connected.	<ul style="list-style-type: none"> <li>• Check indoor addresses.</li> </ul>
L08	L08	—	Indoor unit	Indoor group / addresses not set	Stop of corresponding unit	Address setting has not been performed for indoor units.	<ul style="list-style-type: none"> <li>• Check indoor addresses.</li> </ul> <p><b>Note:</b> This code is displayed when power is turned on for the first time after installation.</p>
L09	—	—	Indoor unit	Indoor capacity not set	Stop of corresponding unit	Capacity setting has not been performed for indoor unit.	Set indoor capacity. (DN = 11)

Main remote controller	Check code		Location of detection	Description	System status	Check code detection condition(s)	Check items (locations)																																																																								
	Outdoor 7-segment display																																																																														
	Check code	Sub-code																																																																													
L10	L10	—	I/F	Outdoor capacity not set	All stop	Initial setting of I/F P.C. board has not been implemented.	• Check model setting of P.C. board for servicing outdoor I/F P.C. board.																																																																								
L20	—	—	Network adaptor Indoor unit	Duplicated central control address	All stop	There is duplication in central control address setting.	• Check central control addresses.																																																																								
L23	—	—	I/F	SW setting mistake	All stop	Outdoor P.C. board (I/F) does not operate normally.	• Check switch setting of outdoor P.C. board (I/F).																																																																								
L28	L28	—	I/F	Too many outdoor units connected	All stop	There are more than 5 outdoor units.	• Check No. of outdoor units connected (Only up to 5 units per system allowed). • Check communication lines between outdoor units. • Check for failure in outdoor P.C. board (I/F).																																																																								
L29	L29	<table border="1"> <thead> <tr> <th colspan="4">P.C. board</th> </tr> <tr> <th colspan="2">Compressor</th> <th colspan="2">Fan Motor</th> </tr> <tr> <th>1</th> <th>2</th> <th>1</th> <th>2</th> </tr> </thead> <tbody> <tr><td>01</td><td>○</td><td></td><td></td></tr> <tr><td>02</td><td></td><td>○</td><td></td></tr> <tr><td>03</td><td>○</td><td>○</td><td></td></tr> <tr><td>08</td><td></td><td></td><td>○</td></tr> <tr><td>09</td><td>○</td><td></td><td>○</td></tr> <tr><td>0A</td><td></td><td>○</td><td>○</td></tr> <tr><td>0B</td><td>○</td><td>○</td><td>○</td></tr> <tr><td>10</td><td></td><td></td><td>○</td></tr> <tr><td>11</td><td>○</td><td></td><td>○</td></tr> <tr><td>12</td><td></td><td>○</td><td>○</td></tr> <tr><td>13</td><td>○</td><td>○</td><td>○</td></tr> <tr><td>18</td><td></td><td></td><td>○</td></tr> <tr><td>19</td><td>○</td><td></td><td>○</td></tr> <tr><td>1A</td><td></td><td>○</td><td>○</td></tr> <tr><td>1B</td><td>○</td><td>○</td><td>○</td></tr> </tbody> </table> <p>Circle (○): Trouble P.C. board</p>	P.C. board				Compressor		Fan Motor		1	2	1	2	01	○			02		○		03	○	○		08			○	09	○		○	0A		○	○	0B	○	○	○	10			○	11	○		○	12		○	○	13	○	○	○	18			○	19	○		○	1A		○	○	1B	○	○	○	I/F	Trouble in No. of P.C. board	All stop	Insufficient number of P.C. board are detected when power is turned on.	• Check model setting of P.C. board for servicing outdoor I/F P.C. board. • Check connection of UART communication connector. • Check compressor P.C. board, fan P.C. board, and I/F P.C. board for failure.
		P.C. board																																																																													
Compressor		Fan Motor																																																																													
1	2	1	2																																																																												
01	○																																																																														
02		○																																																																													
03	○	○																																																																													
08			○																																																																												
09	○		○																																																																												
0A		○	○																																																																												
0B	○	○	○																																																																												
10			○																																																																												
11	○		○																																																																												
12		○	○																																																																												
13	○	○	○																																																																												
18			○																																																																												
19	○		○																																																																												
1A		○	○																																																																												
1B	○	○	○																																																																												
		00	I/F	The number of inverter P.C. boards is abnormal.	All stop	When there is much number of an inverter P.C. board to model setting of an interface P.C. board.	• Check I/F P.C. board exchange has been correctly performed as a procedure. • Check for failure in I/F P.C. board. • Check for inverter P.C. board for compressors and inverter P.C. board for fan.																																																																								
L30	L30	Detected indoor address	Indoor unit	Indoor external interlock (External abnormal input)	Stop of corresponding unit	• Indoor unit has been shut down due to external abnormal input signal.	<b>When external device is connected:</b> 1) Check for trouble in external device. 2) Check for trouble in indoor P.C. board. <b>When external device is not connected:</b> 1) Check for trouble in indoor P.C. board.																																																																								
—	L31	—	I/F	Extended IC trouble	Continued operation	There is part failure in P.C. board (I/F).	Check outdoor P.C. board (I/F).																																																																								
P01	—	—	Indoor unit	Indoor fan motor trouble	Stop of corresponding unit		• Check the lock of fan motor (AC fan). • Check wiring.																																																																								
P03	P03	—	I/F	Discharge temperature TD1 trouble	All stop	Discharge temperature (TD1) exceeds 115 °C.	• Check outdoor service valves (gas side, liquid side) to confirm full opening. • Check outdoor PMVs (PMV1, 2, 3, 4) for clogging. • Check resistance characteristics of TD1 sensor. • Check for insufficiency in refrigerant quantity. • Check for failure in 4-way valve. • Check for leakage of SV4 circuit. • Check SV4 circuit (wiring or installation trouble in SV41 or SV42).																																																																								

Main remote controller	Check code		Location of detection	Description	System status	Check code detection condition(s)	Check items (locations)
	Outdoor 7-segment display						
	Check code	Sub-code					
P04	P04	1*: Compressor 1 side 2*: Compressor 2 side	I/F	Activation of high-pressure SW	All stop	High-pressure SW is activated.	<ul style="list-style-type: none"> <li>• Check connection of high-pressure SW connector.</li> <li>• Check for failure in Pd pressure sensor.</li> <li>• Check outdoor service valves (gas side, liquid side) to confirm full opening.</li> <li>• Check for failure in outdoor fan.</li> <li>• Check for failure in outdoor fan motor.</li> <li>• Check outdoor PMVs (PMV1, 2, 3) for clogging.</li> <li>• Check indoor/outdoor heat exchangers for clogging.</li> <li>• Check for short-circuiting of outdoor suction/discharge air flows.</li> <li>• Check for failure in outdoor P.C. board (I/F).</li> <li>• Check for trouble in indoor fan system (possible cause of air flow reduction).</li> <li>• Check opening status of indoor PMV.</li> <li>• Check indoor-outdoor communication line for wiring trouble.</li> <li>• Check for failure operation of check valve in discharge pipe convergent section.</li> <li>• Check gas balancing SV4 valve circuit.</li> <li>• Check for refrigerant overcharging.</li> </ul>
P05	P05	00: Power detection trouble 01: Open phase 02: Power supply miswiring	I/F	Power detection trouble / Open phase detection / Power supply miswiring	All stop	<ul style="list-style-type: none"> <li>• Open phase is detected when power is turned on.</li> <li>• Inverter DC voltage is too high (overvoltage) or too low (undervoltage).</li> </ul>	<ul style="list-style-type: none"> <li>• Check for failure in outdoor P.C. board (I/F).</li> <li>• Check wiring of outdoor power supply.</li> <li>• Check power supply voltage.</li> </ul>
		1*: Compressor 1 side 2*: Compressor 2 side	Compressor P.C. board	Compressor Vdc trouble			
P07	P07	1*: Compressor 1 side 2*: Compressor 2 side	Compressor P.C. board	Heat sink overheating trouble	All stop	Temperature sensor built into IPM (TH) is overheated.	<ul style="list-style-type: none"> <li>• Check outdoor fan system trouble.</li> <li>• Check IPM and heat sink for thermal performance for failure installation. (e.g. mounting screws and thermal conductivity)</li> <li>• Check for failure in Compressor P.C. board. (failure IPM built-in temperature sensor (TH))</li> </ul>
		01: Compressor 1 heat sink trouble 02: Compressor 2 heat sink trouble 04: Heat sink dew condensation	I/F	Heat sink overheating trouble Heat sink dew condensation trouble	All stop	Condensation detection on heat sink has occurred four times or more in operation. Temperature sensor built into IPM (TH) is overheated.	<ul style="list-style-type: none"> <li>• Check outdoor fan system trouble.</li> <li>• Check IPM and heat sink for thermal performance for troubled installation. (e. g. mounting screws and thermal conductivity)</li> <li>• Check for failure in compressor P.C. board. (failure IPM built-in temperature sensor (TH))</li> <li>• Check shortage of refrigerant.</li> <li>• Check outdoor service valves.</li> <li>• Check connection of TL2 sensor.</li> <li>• Check resistance characteristics of TL2 sensor.</li> <li>• Check resistance characteristics of TO sensor.</li> <li>• Check malfunctions of Pd and Ps sensors.</li> <li>• Check outdoor I/F P.C. board malfunction.</li> <li>• Check PMV2 and PMV3</li> </ul>

Main remote controller	Check code		Location of detection	Description	System status	Check code detection condition(s)	Check items (locations)
	Outdoor 7-segment display						
	Check code	Sub-code					
P10	P10	Detected indoor address	Indoor unit	Indoor overflow trouble	All stop	<ul style="list-style-type: none"> <li>• Float switch operates.</li> <li>• Float switch circuit is open-circuited or disconnected at connector.</li> </ul>	<ul style="list-style-type: none"> <li>• Check float switch connector.</li> <li>• Check operation of drain pump.</li> <li>• Check drain pump circuit.</li> <li>• Check drain pipe for clogging.</li> <li>• Check for failure in indoor P.C. board.</li> </ul>
P11	—	—	I/F	Outdoor heat exchanger freeze trouble	All stop	<ul style="list-style-type: none"> <li>• Outdoor heat exchanger remaining frost detection has occurred eight times or more due to abnormal frost formation in heating operation.</li> </ul>	<ul style="list-style-type: none"> <li>• Check shortage of refrigerant.</li> <li>• Check connection of TE1, TE2 and TE3 sensors.</li> <li>• Check resistance characteristics of TE1, TE2, and TE3 sensors.</li> <li>• Check disconnection of TS1 sensor.</li> <li>• Check resistance characteristics of TS1 sensor.</li> <li>• Check outdoor I/F P.C. board malfunction.</li> <li>• Check operation of 4 way valve.</li> <li>• Check operation of outdoor PMV (1, 2, 3).</li> <li>• Check short circuit from outlet air to inlet air.</li> </ul>
P12	—	—	Indoor unit	Indoor fan motor trouble	Stop of corresponding unit	<ul style="list-style-type: none"> <li>• Motor speed measurements continuously deviate from target value.</li> <li>• Overcurrent protection is activated.</li> </ul>	<ul style="list-style-type: none"> <li>• Check connection of fan connector and wiring.</li> <li>• Check for failure in fan motor.</li> <li>• Check for failure in indoor P.C. board.</li> <li>• Check impact of outside air treatment (OA).</li> </ul>
P13	P13	—	I/F	Outdoor liquid backflow detection trouble	All stop	<p>&lt;During cooling operation&gt; When system is in cooling operation, high pressure is detected in the unit that has been turned off.</p> <p>&lt;During heating operation&gt; When system is in heating operation, low pressure is detected to be high in unit that has been turned off.</p>	<ul style="list-style-type: none"> <li>• Check full-close operation of outdoor PMV (1, 2, 3, 4).</li> <li>• Check for failure in Pd or Ps sensor.</li> <li>• Check failure in outdoor P.C. board (I/F).</li> <li>• Check capillary of oil separator oil return circuit for clogging.</li> <li>• Check for leakage of check valve in discharge pipe</li> </ul>
P15	P15	01: TS condition	I/F	Gas leak detection (TS1 condition)	All stop	Protective shutdown due to sustained suction temperature at or above judgment criterion for at least 10 minutes is repeated four times or more. <TS trouble judgment criterion> In cooling operation: 60 °C In heating operation: 40 °C	<ul style="list-style-type: none"> <li>• Check for insufficiency in refrigerant quantity.</li> <li>• Check outdoor service valves (gas side, liquid side) to confirm full opening.</li> <li>• Check PMVs (PMV1, 2, 3, 4) for clogging.</li> <li>• Check resistance characteristics of TS1 sensor.</li> <li>• Check for failure in 4-way valve.</li> <li>• Check SV4 circuit for leakage</li> </ul>
		02: TD condition	I/F	Gas leak detection (TD condition)	All stop	Protective shutdown due to sustained discharge temperature (TD1 or TD2) at or above 108 °C for at least 10 minutes is repeated four times or more.	<ul style="list-style-type: none"> <li>• Check for insufficiency in refrigerant quantity.</li> <li>• Check PMVs (PMV 1, 2, 3, 4) for clogging.</li> <li>• Check resistance characteristics of TD1 and TD2 sensors.</li> <li>• Check indoor filter for clogging.</li> <li>• Check piping for clogging.</li> <li>• Check SV4 circuit (for leakage or coil installation trouble).</li> </ul>

Main remote controller	Check code		Location of detection	Description	System status	Check code detection condition(s)	Check items (locations)
	Outdoor 7-segment display						
	Check code	Sub-code					
P17	P17	—	I/F	Discharge temperature TD2 trouble	All stop	Discharge temperature (TD2) exceeds 115 °C.	<ul style="list-style-type: none"> <li>• Check outdoor service valves (gas side, liquid side) to confirm full opening.</li> <li>• Check outdoor PMVs (PMV1, 2, 3, 4) for clogging.</li> <li>• Check resistance characteristics of TD2 sensor.</li> <li>• Check for failure in 4-way valve.</li> <li>• Check SV4 circuit for leakage.</li> <li>• Check SV4 circuit (for wiring or installation trouble involving SV41 and SV42).</li> </ul>
P19	P19	Detected outdoor unit No.	I/F	4-way valve reversing trouble	All stop	Abnormal refrigerating cycle data is collected during heating operation.	<ul style="list-style-type: none"> <li>• Check for failure in main body of 4-way valve.</li> <li>• Check for coil failure in 4-way valve and loose connection of its connector.</li> <li>• Check resistance characteristics of TS1 and TE1, TE2 sensors.</li> <li>• Check output voltage characteristics of Pd and Ps pressure sensors.</li> <li>• Check for wiring trouble involving TE1 and TL1 sensors.</li> </ul>
P20	P20	—	I/F	Activation of high-pressure protection	All stop	<p>&lt;During cooling operation&gt; Pd sensor detects pressure equal to or greater than 3.85 MPa.</p> <p>&lt;During heating operation&gt; Pd sensor detects pressure equal to or greater than 3.6 MPa.</p>	<ul style="list-style-type: none"> <li>• Check for failure in Pd pressure sensor.</li> <li>• Check service valves (gas side, liquid side) to confirm full opening.</li> <li>• Check for failure in outdoor fan.</li> <li>• Check for failure in outdoor fan motor.</li> <li>• Check outdoor PMV (PMV1, 2, 3, 4) for clogging.</li> <li>• Check indoor/outdoor heat exchangers for clogging.</li> <li>• Check for short-circuiting of outdoor suction/discharge air flows.</li> <li>• Check for failure in outdoor P.C. board (I/F).</li> <li>• Check for failure in indoor fan system (possible cause of air flow reduction).</li> <li>• Check opening status of indoor PMV.</li> <li>• Check indoor-outdoor communication line for wiring trouble.</li> <li>• Check for trouble operation of check valve in discharge pipe convergent section.</li> <li>• Check gas balancing SV4 valve circuit.</li> <li>• Check for refrigerant overcharging.</li> </ul>

Check code			Location of detection	Description	System status	Check code detection condition(s)	Check items (locations)
Main remote controller	Outdoor 7-segment display						
	Check code	Sub-code					
P22	P22	1*: Fan P.C. board 1 2*: Fan P.C. board 2	Fan INV. P.C. board	Outdoor fan P.C. board trouble	All stop	Protected operation of Fan inverter P.C. board	<ul style="list-style-type: none"> <li>• Check fan motor.</li> <li>• Check for failure in fan P.C. board.</li> <li>• Check connection of fan motor connector.</li> <li>• Check power voltage of the main power supply.</li> </ul>
P26	P26	1*: Compressor 1 side 2*: Compressor 2 side	Compressor P.C. board	IPM, Compressor shortcircuit protection trouble	All stop	Overcurrent is momentarily detected during startup of compressor.	<ul style="list-style-type: none"> <li>• Check connector connection and wiring on compressor P.C. board.</li> <li>• Check for failure in compressor (layer shortcircuit).</li> <li>• Check for failure in outdoor P.C. board ( Compressor).</li> </ul>
P29	P29	1*: Compressor 1 side 2*: Compressor 2 side	Compressor P.C. board	Compressor position detection circuit trouble	All stop	Position detection is not going on normally.	<ul style="list-style-type: none"> <li>• Check wiring and connector connection.</li> <li>• Check for compressor layer short-circuit.</li> <li>• Check for failure in compressor P.C. board.</li> </ul>
P31	—	—	Indoor unit	Other indoor trouble (group follower unit trouble)	Stop of corresponding unit	There is trouble in other indoor unit in group, resulting in detection of E07/L07/L03/L08.	<ul style="list-style-type: none"> <li>• Check indoor P.C. board.</li> </ul>

## Check codes Detected by Central Control Device

Main remote controller	Check code		Location of detection	Description	System status	Check code detection condition(s)	Check items (locations)
	Outdoor 7-segment display						
	Check code	Sub-code					
C05	—		Central control device	Central control device transmission trouble	Continued operation	Central control device is unable to transmit signal.	<ul style="list-style-type: none"> <li>• Check for failure in central control device.</li> <li>• Check for failure in central control communication line.</li> <li>• Check termination resistance setting.</li> </ul>
C06	—		Central control device	Central control device reception trouble	Continued operation	Central control device is unable to receive signal.	<ul style="list-style-type: none"> <li>• Check for failure in central control device.</li> <li>• Check for failure in central control communication line.</li> <li>• Check terminator resistor setting.</li> <li>• Check power supply for devices at other end of central control communication line.</li> <li>• Check failure in P.C. boards of devices at other end of central control communication line.</li> </ul>
C12	—		General-purpose device I/F	Batch alarm for general-purpose device control interface	Continued operation	Trouble signal is input to control interface for general-purpose devices.	<ul style="list-style-type: none"> <li>• Check trouble input.</li> </ul>
P30	Differs according to nature of alarm-causing trouble		Central control device	Group control follower unit trouble	Continued operation	Trouble occurs in follower unit under group control. ([P30] is displayed on central control remote controller.)	<ul style="list-style-type: none"> <li>• Check check code of unit that has generated alarm.</li> </ul>
	(L20 displayed.)			Duplicated central control address	Continued operation	There is duplication in central control addresses.	<ul style="list-style-type: none"> <li>• Check address settings.</li> </ul>



### ▼ Points to Note When Servicing Compressor

(1) When checking the outputs of inverters, remove the wiring from all the compressors.

### ▼ How to Check Inverter Output

- (1) Turn off the power supply.
- (2) Remove compressor leads from the compressor P.C. board.  
(The model with two compressor should remove the wiring for two sets (6 leads).)
- (3) Turn on the power supply and start cooling or heating operation.
- (4) Check the output voltage across each pair of inverter-side. If the result is unsatisfactory according to the judgment criteria given in the table below, replace the compressor P.C. board.

No.	Measured leads	Criterion
1	CN201 - CN202	380~580V
2	CN202 - CN203	380~580V
3	CN203 - CN201	380~580V

### ▼ How to Check Resistance of Compressor Winding

- (1) Turn off the power supply.
- (2) Remove compressor leads from the compressor P.C. board. (Be sure to remove all the leads.)
- (3) With each compressor, check the phase-to-phase winding resistances and winding-to-outdoor cabinet resistance using a multimeter.
  - Earth trouble?  
→ It is normal if the winding-to-outdoor cabinet resistance is 10MΩ or more.
  - Inter-winding short circuit?  
→ It is normal if the phase-to-phase resistances are in the 0.1-1.0Ω range. (Use a digital multimeter.)

### ▼ How to Check Outdoor Fan Motor

- (1) Turn off the power supply.
- (2) Remove fan motor leads from the fan P.C. board for the outdoor fan.
- (3) Rotate the fan by hand. If the fan does not turn, the fan motor is faulty (locked up). Replace the fan motor. If the fan turns, measure the phase-to-phase winding resistances using a multimeter. It is normal if the measurements are in the 8.1-9.9 range. (Use a digital multimeter.)

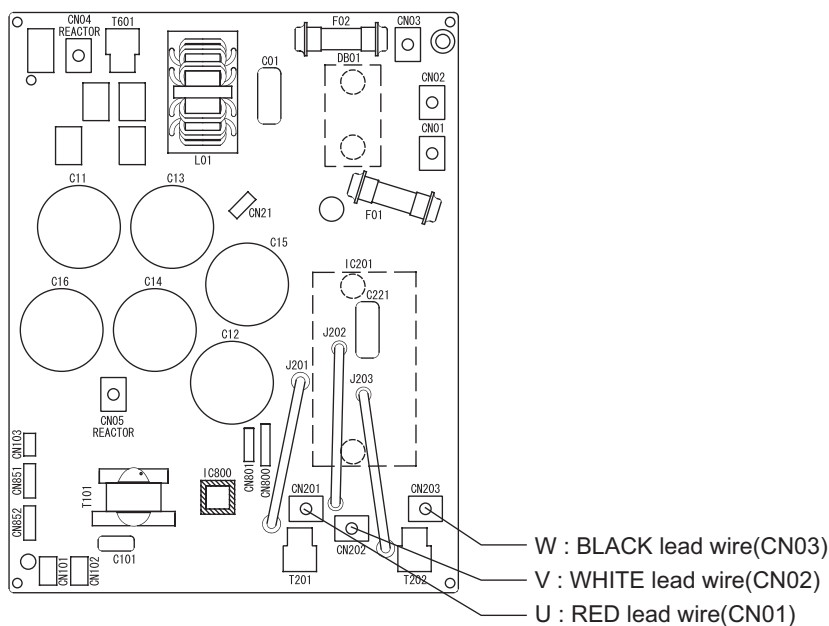

## 9-5. Diagnostic Procedure for Each Check Code (Indoor Unit)

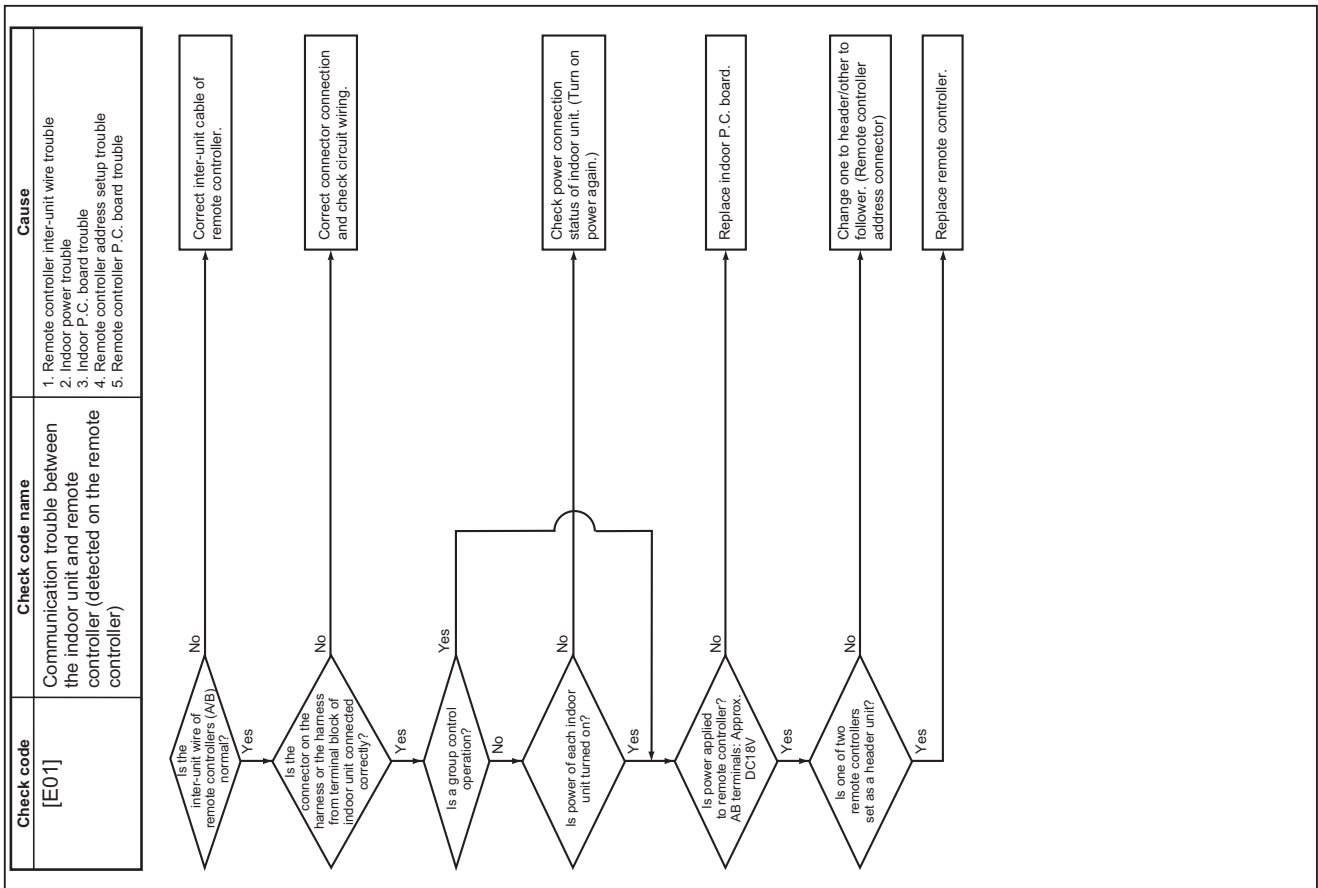
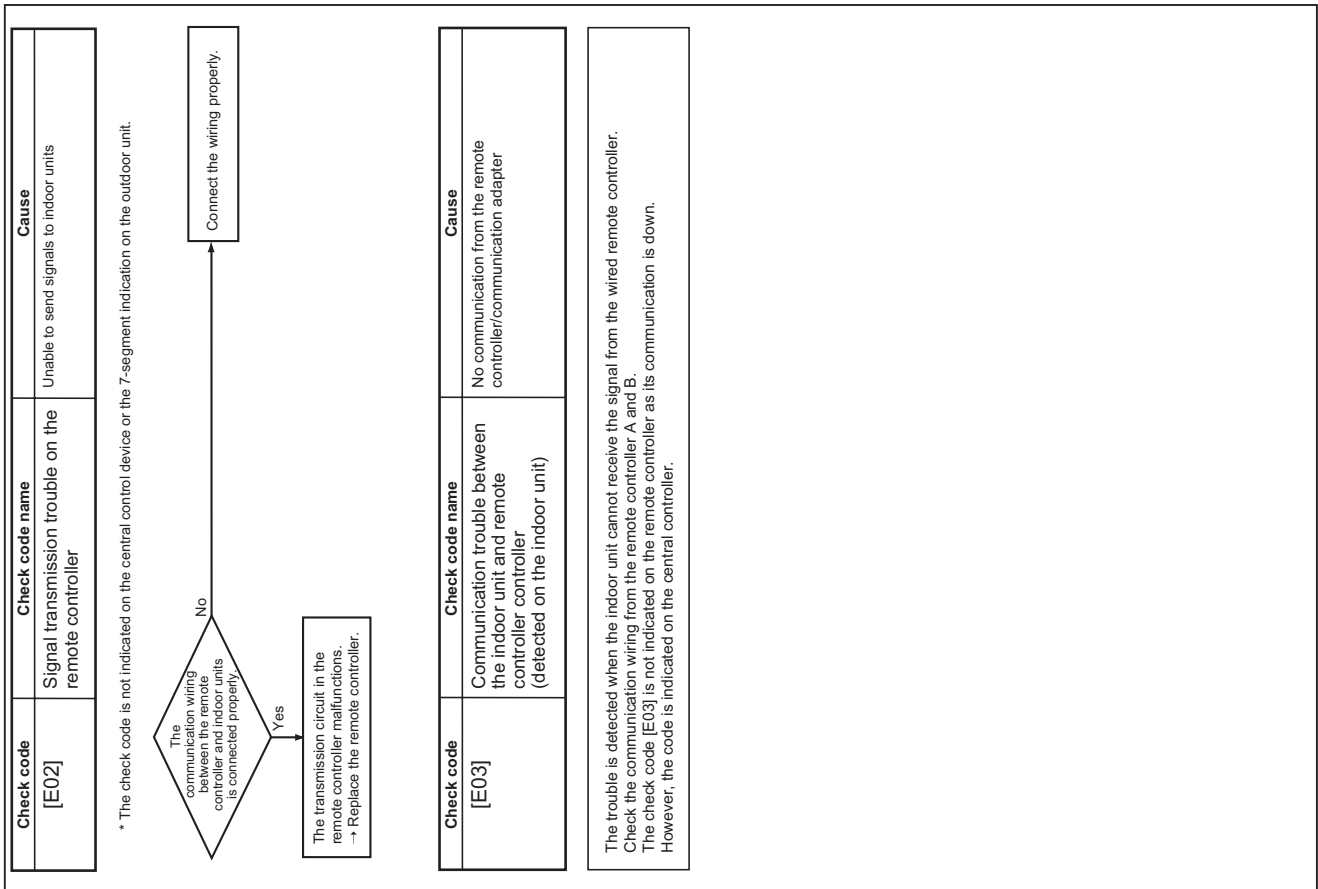

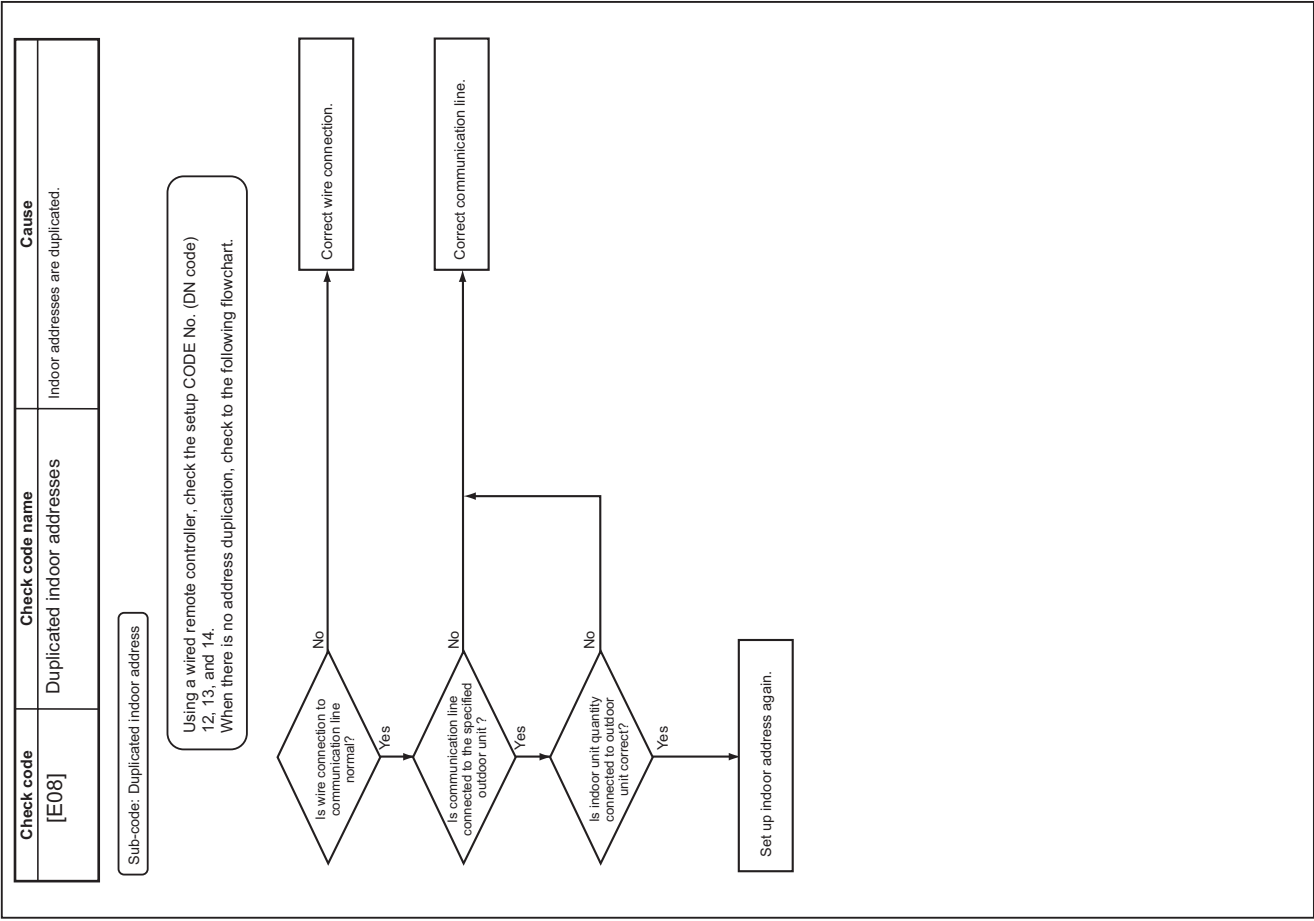
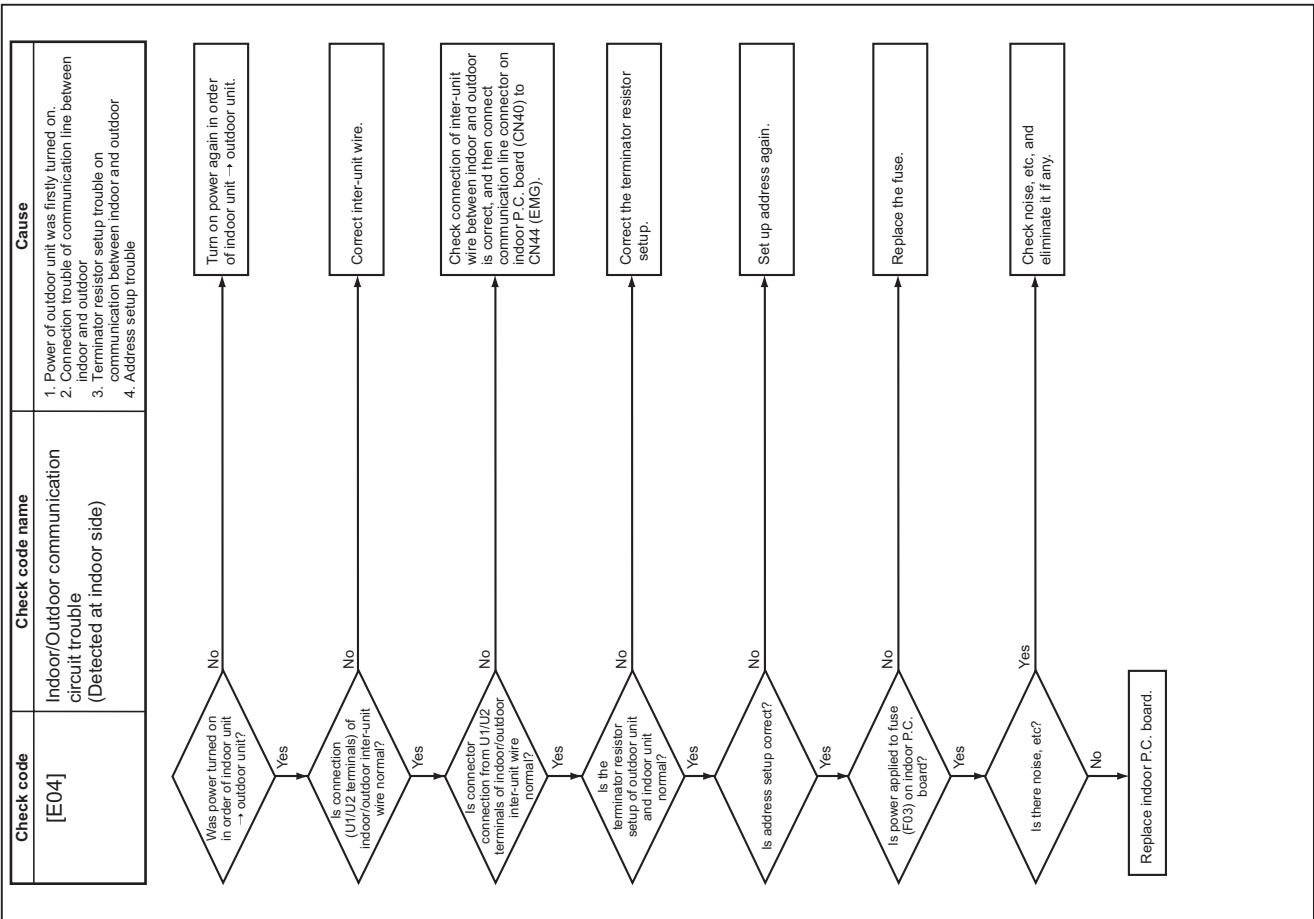

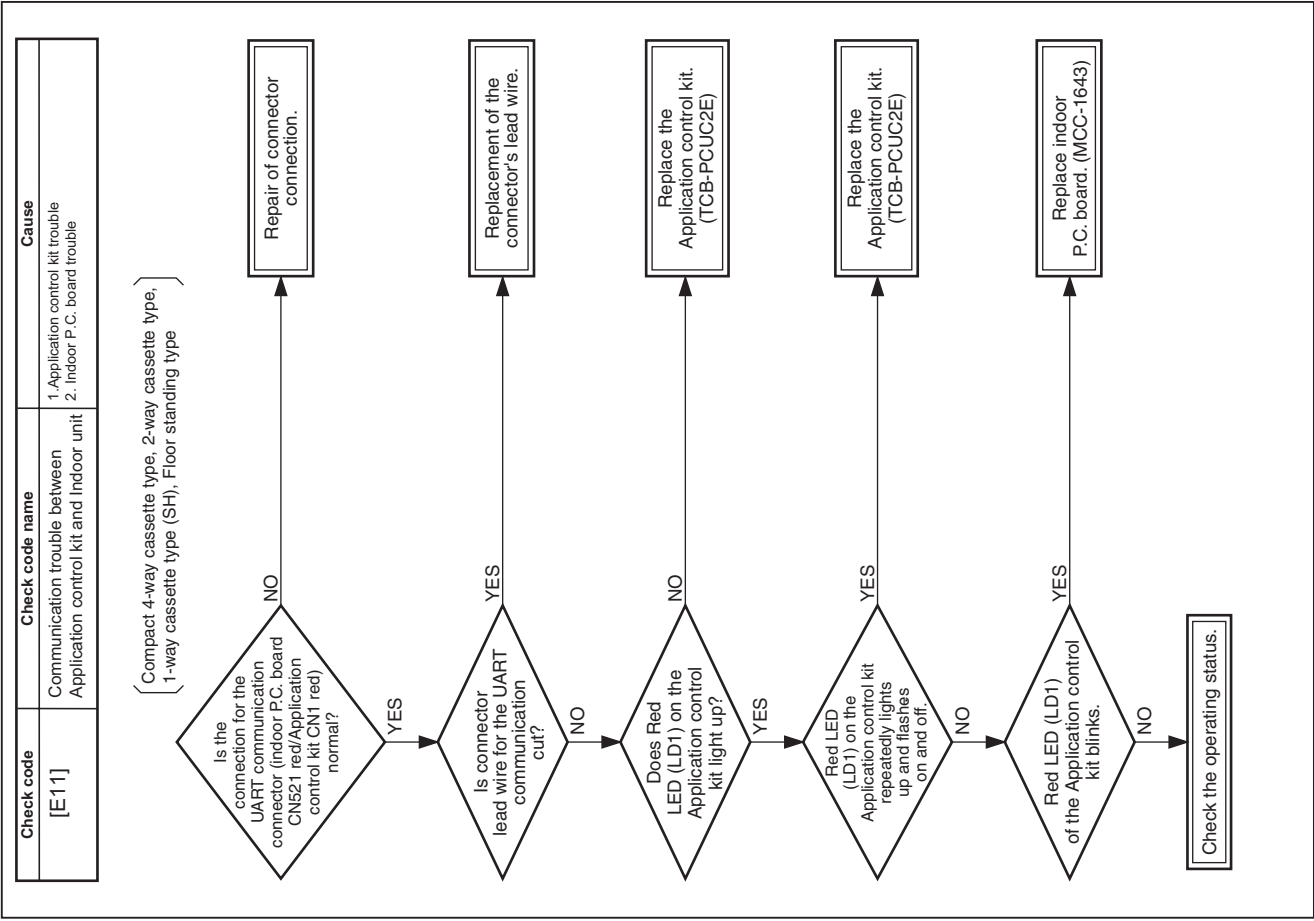
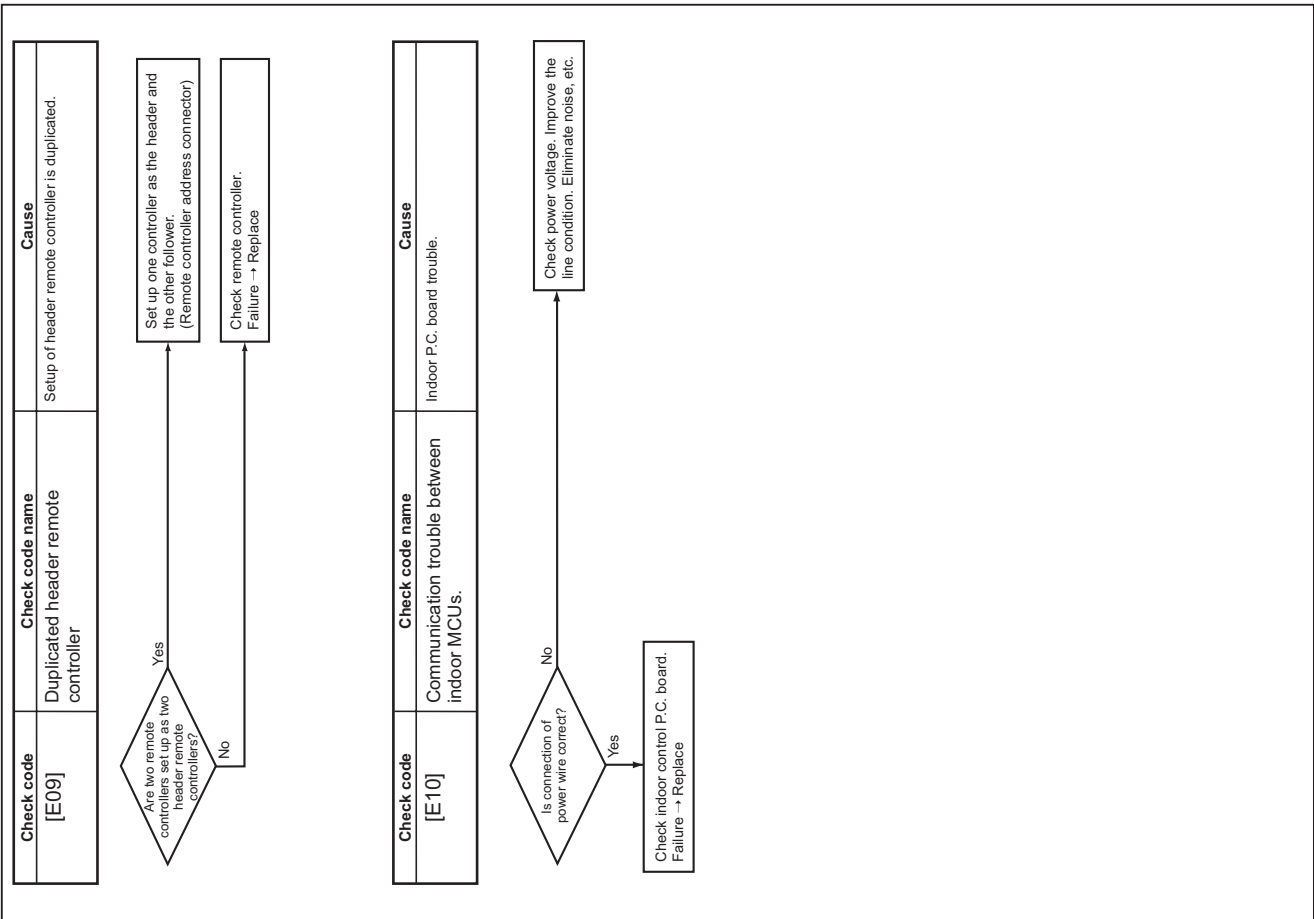

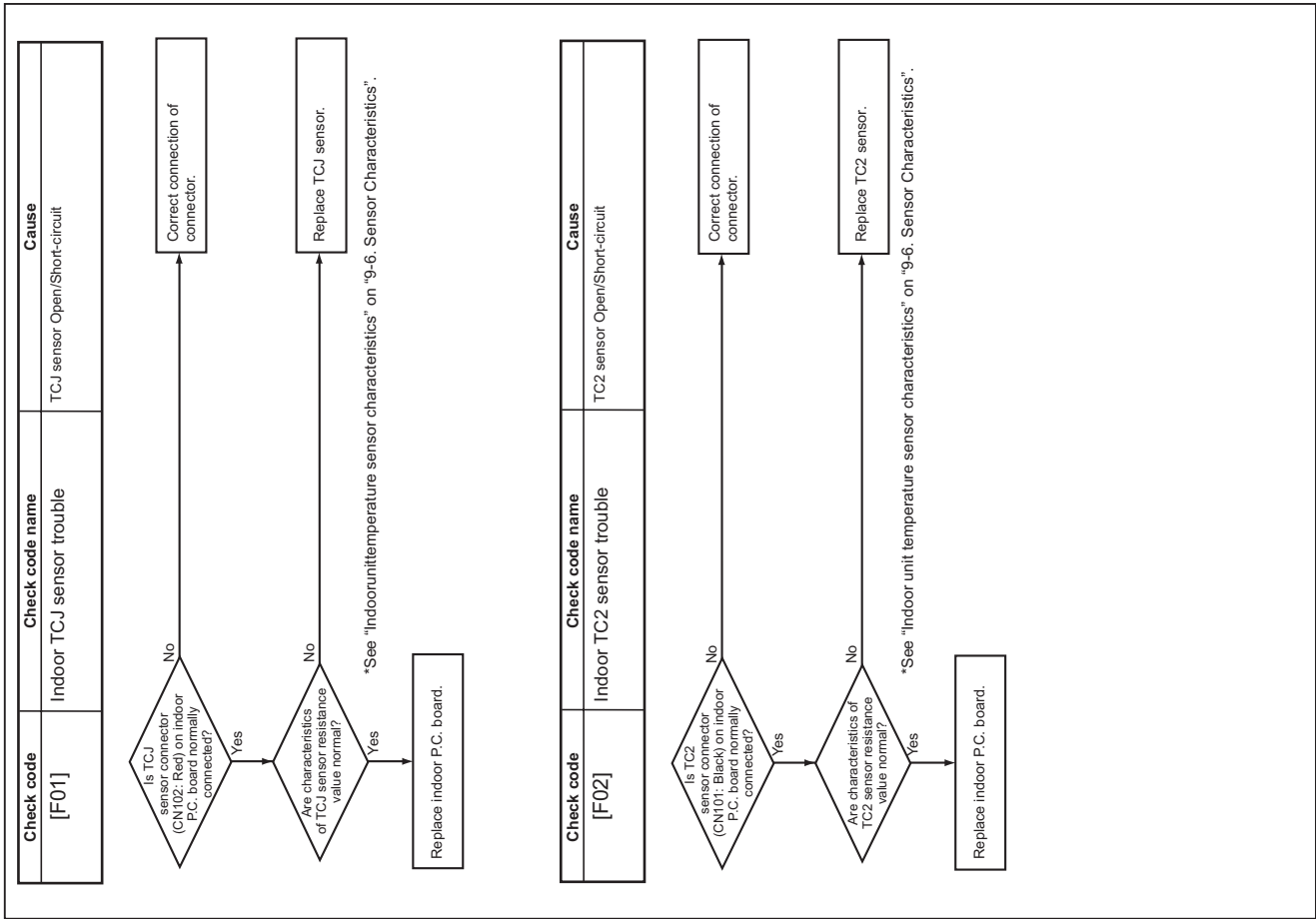
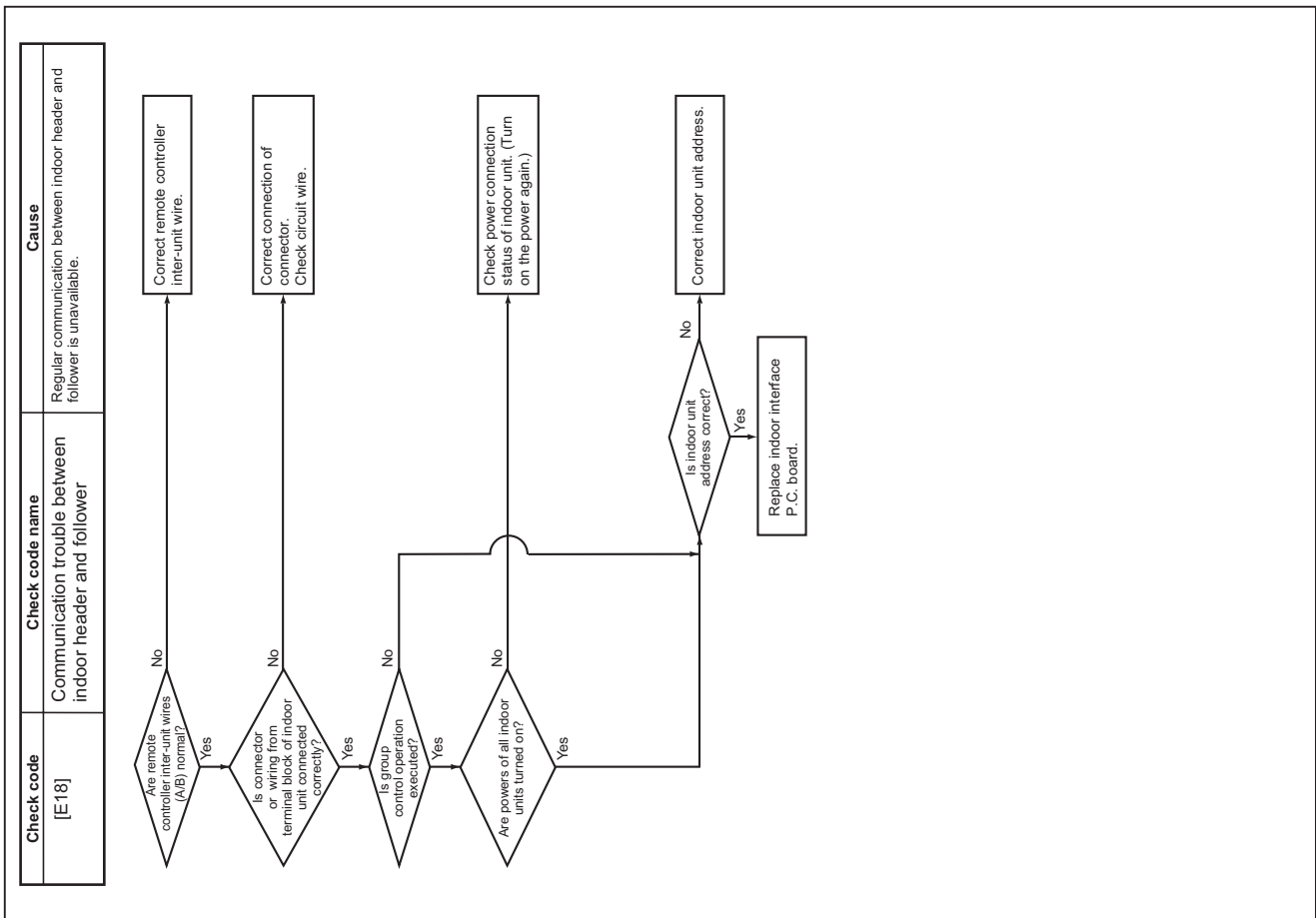

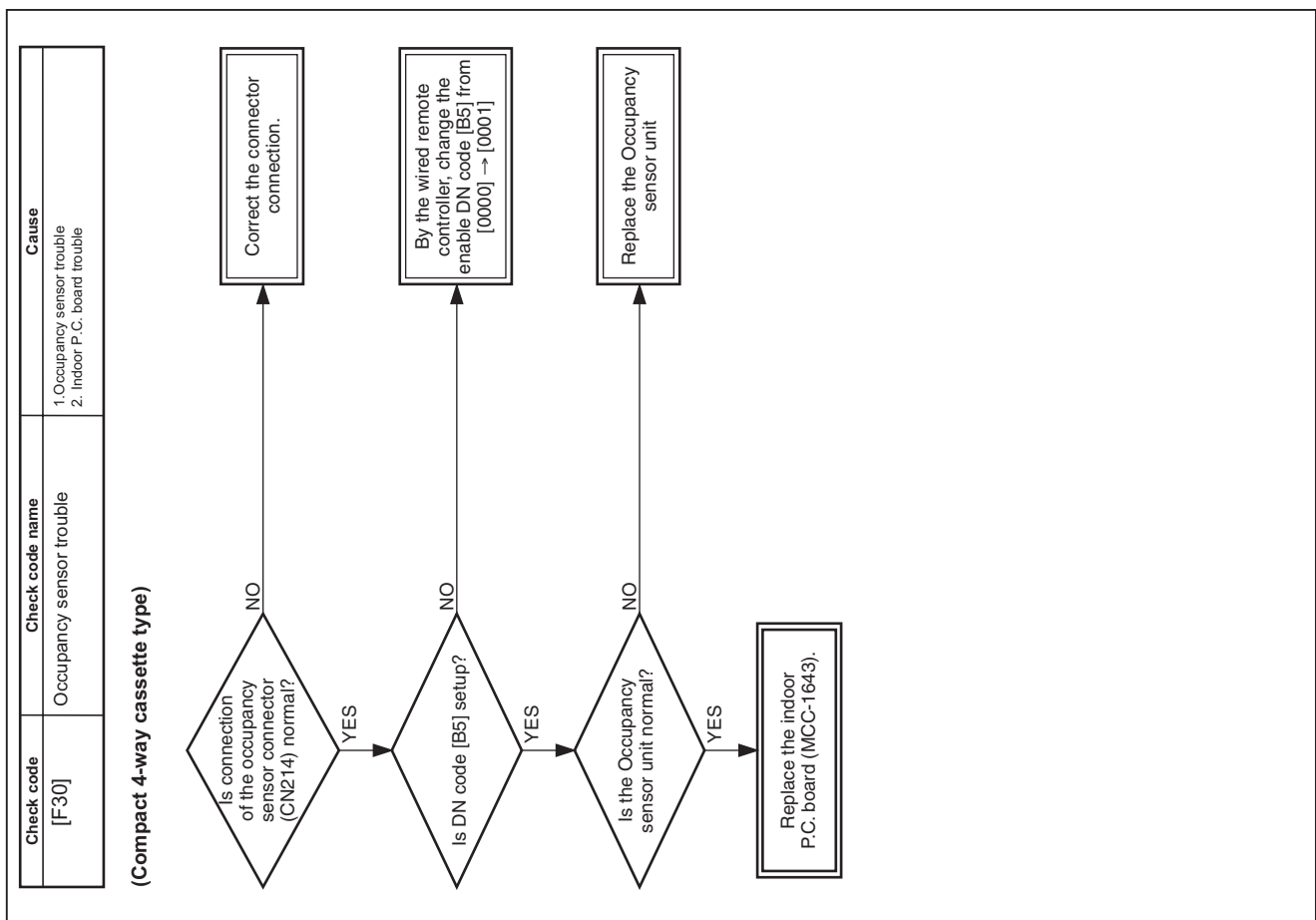
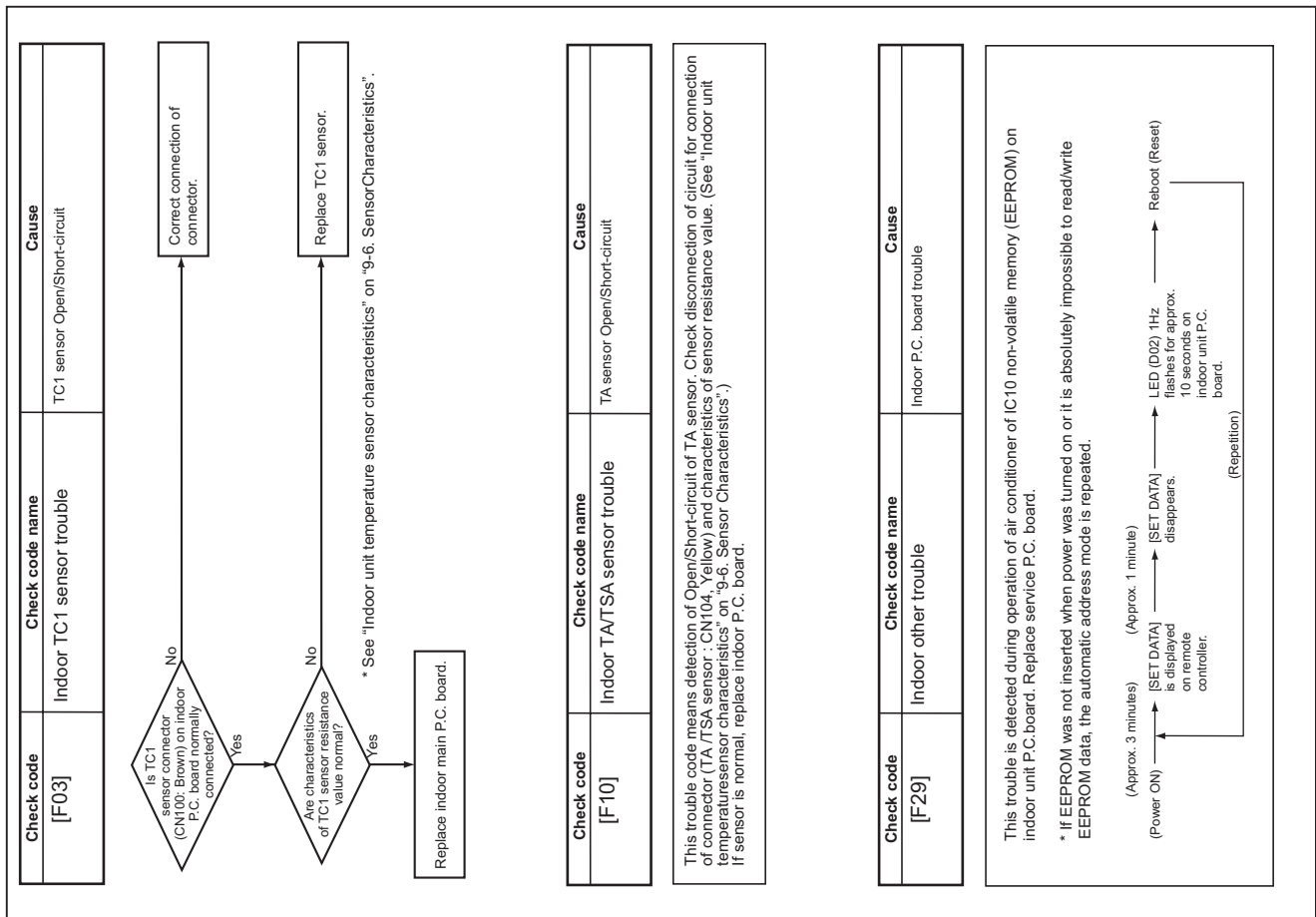

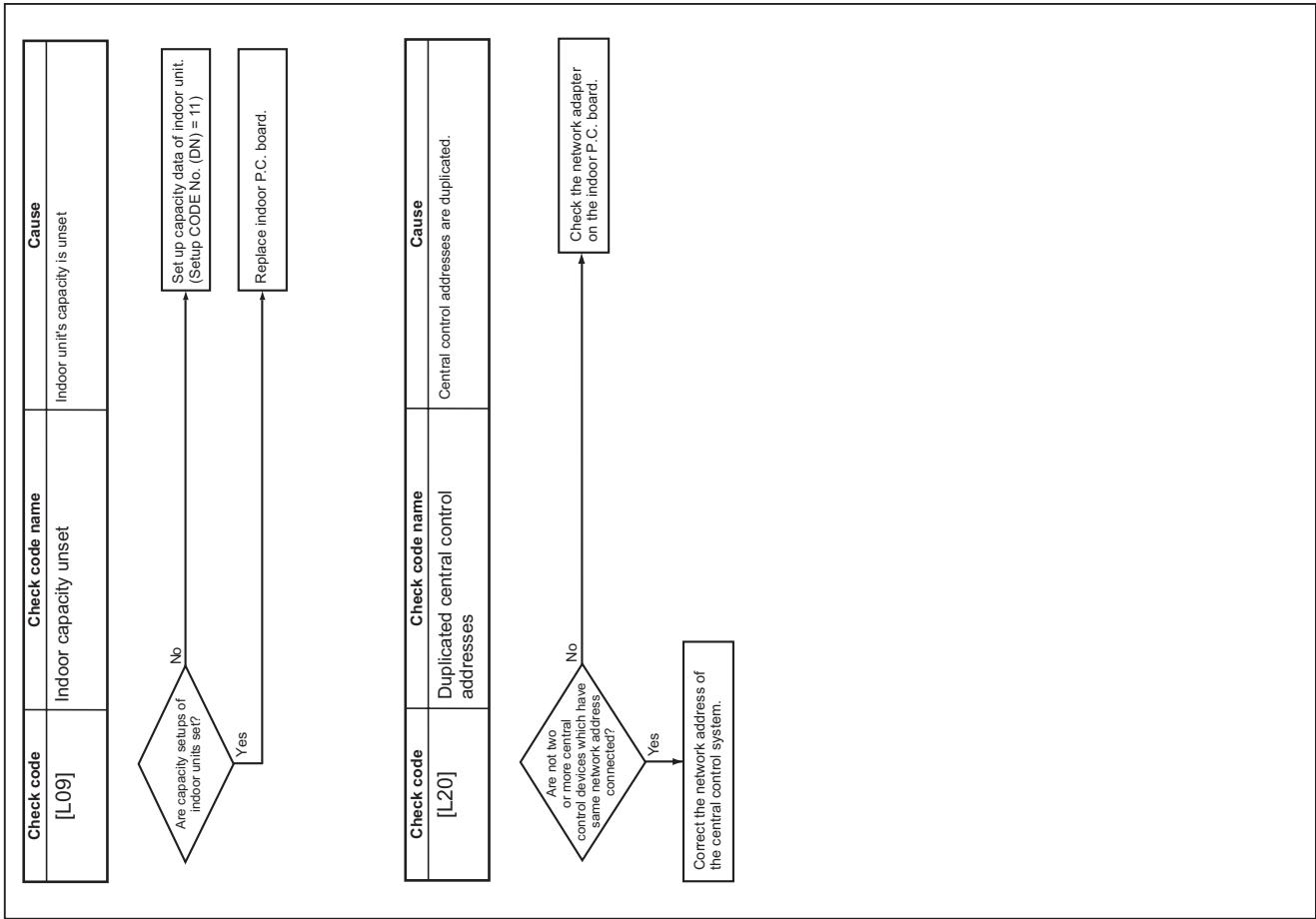
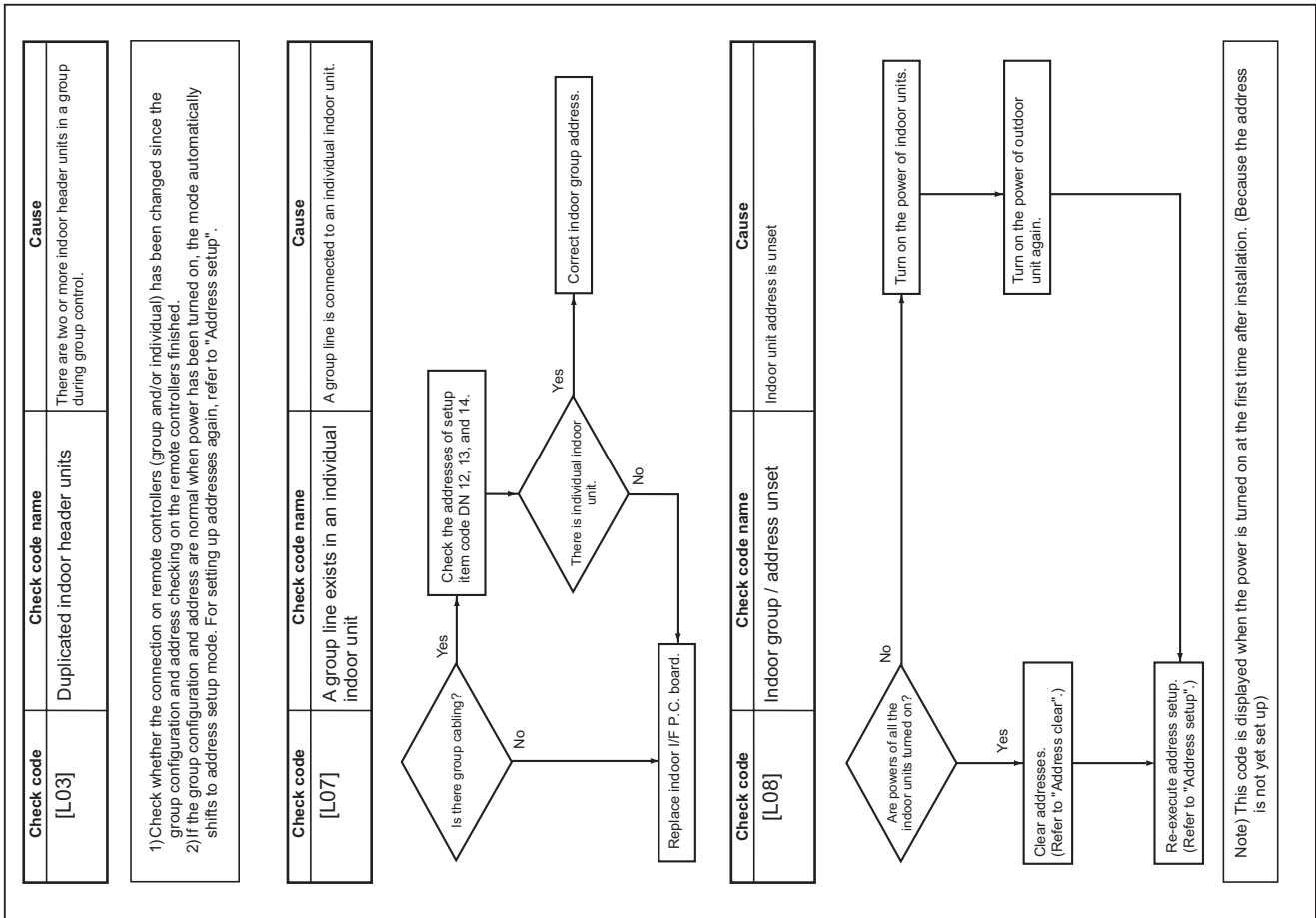

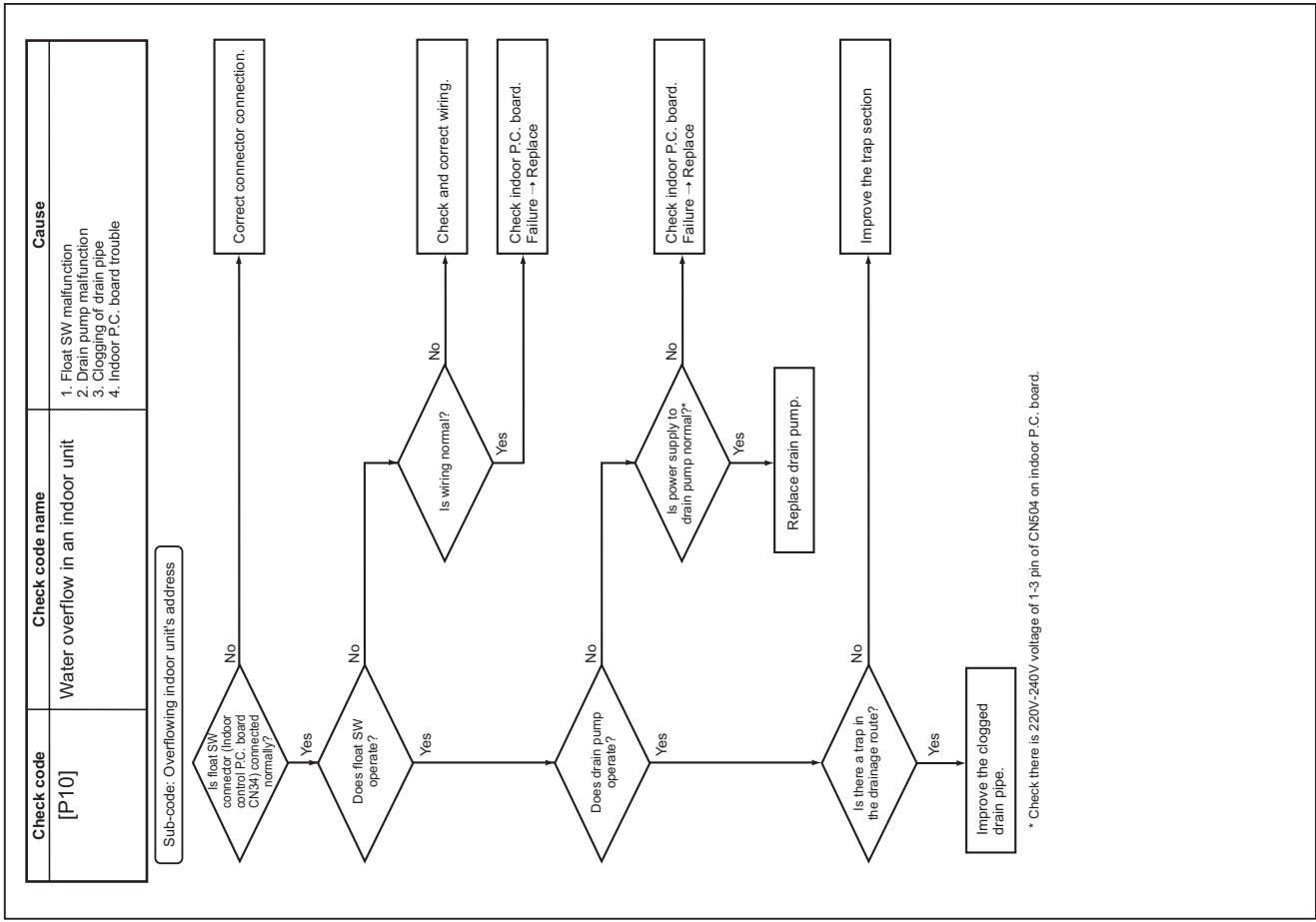
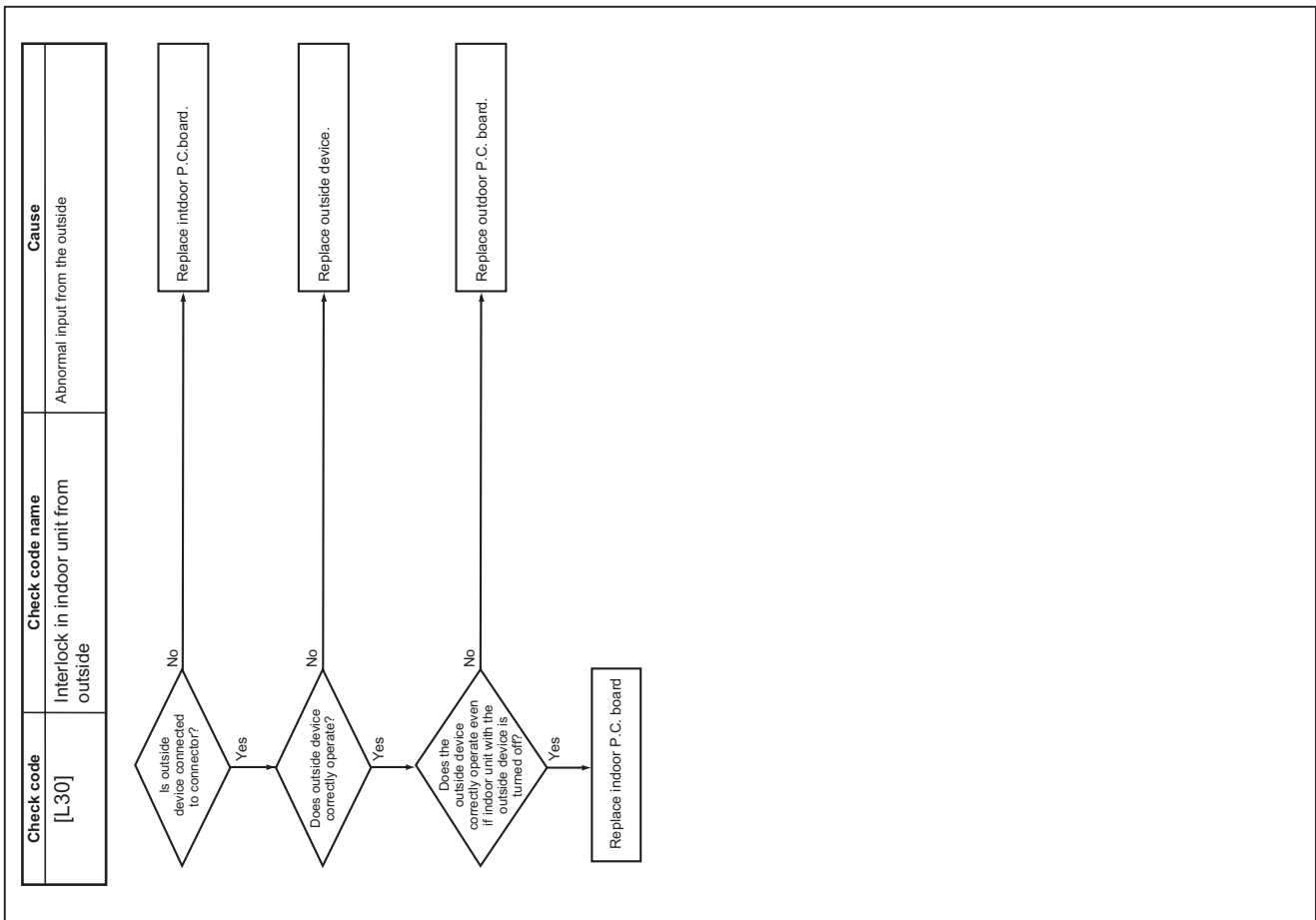



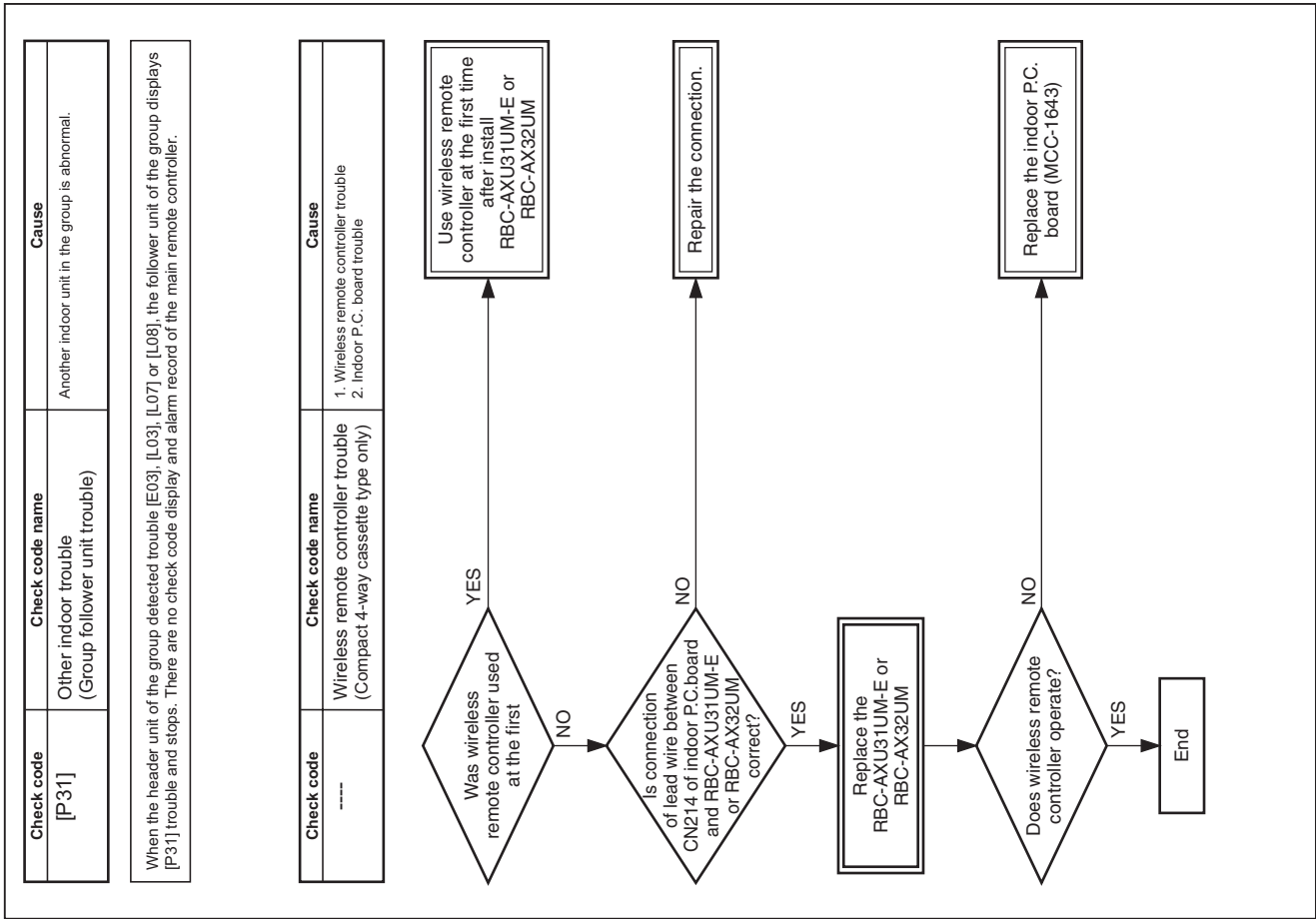
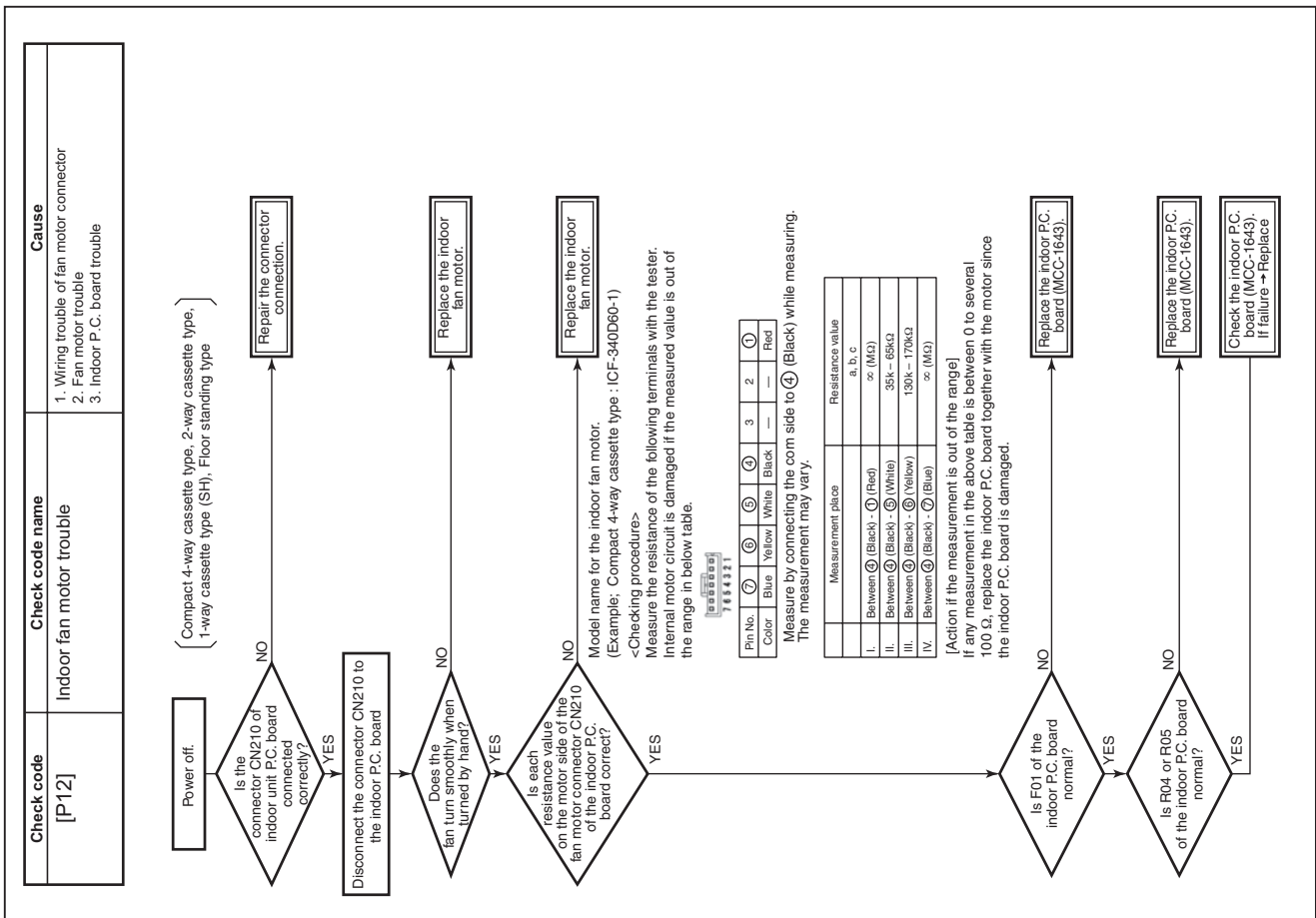

## 9-6. Sensor characteristics

### Indoor unit

#### ▼ Temperature sensor characteristics

Indoor TA sensor

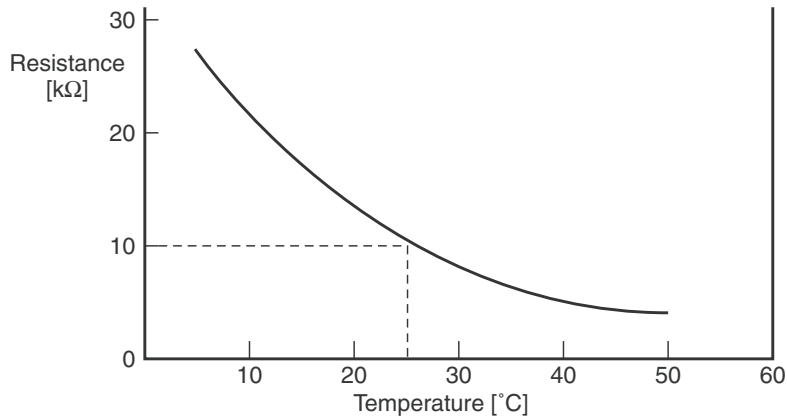

Temperature [°C]	Resistance [kΩ]
0	33.9
5	26.1
10	20.3
15	15.9
20	12.6
25	10.0
30	8.0
35	6.4
40	5.2
45	4.2
50	3.5
55	2.6
60	2.4

Indoor TC1 sensor

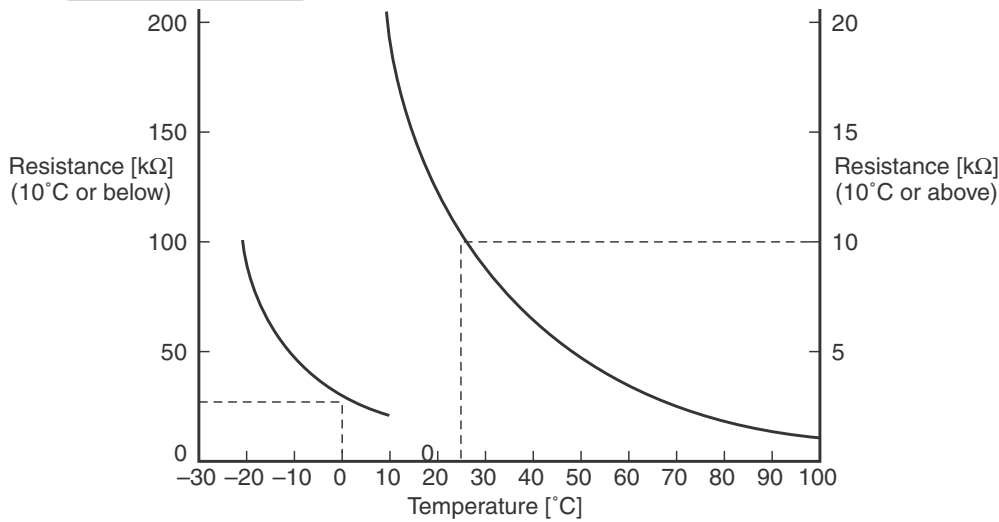

Temperature [°C]	Resistance [kΩ]
-20	99.9
-15	74.1
-10	55.6
-5	42.2
0	32.8
5	25.4
10	19.8
15	15.6
20	12.4
25	10.0
30	8.1
35	6.5
40	5.3
45	4.4
50	3.6
55	3.0
60	2.5
65	2.1
70	1.8
75	1.5
80	1.3
85	1.1
90	1.0
95	0.8
100	0.7

Indoor TC2 and TCJ sensors

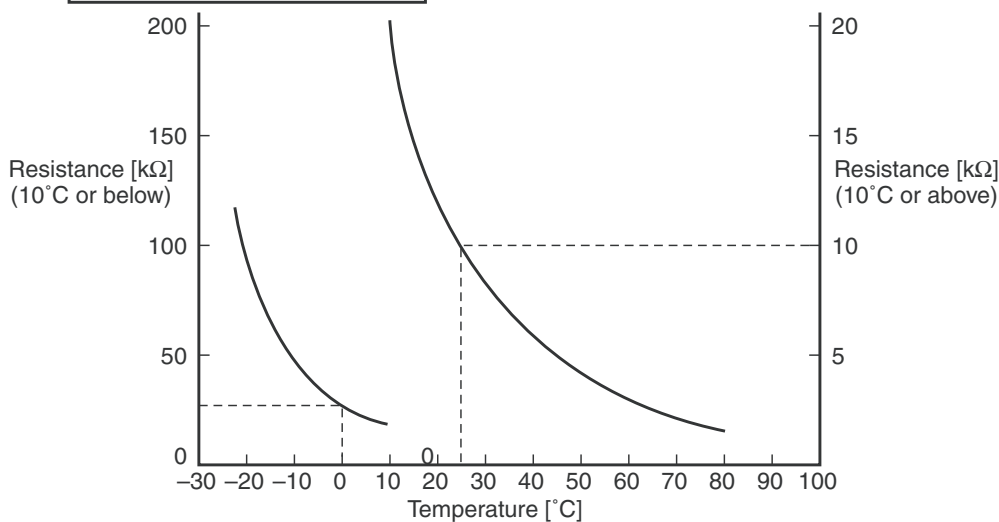

Temperature [°C]	Resistance [kΩ]
-20	115.2
-15	84.2
-10	62.3
-5	46.6
0	35.2
5	26.9
10	20.7
15	16.1
20	12.6
25	10.0
30	8.0
35	6.4
40	5.2
45	4.2
50	3.5
55	2.8
60	2.4
65	2.0
70	1.6
75	1.4
80	1.2

## ▼ Winding resistance of PMV (Pulse Motor Vale) coil

Measure position	Resistance value
White - Red (COM)	180 to 220 Ω
Yellow - Red (COM)	
Orange - Red (COM)	
Blue - Red (COM)	

at 20°C

## 9-7. Maintenance list

Aiming in environmental preservation, it is strictly recommended to clean and maintain the indoor/outdoor units of the operating air conditioning system regularly to secure effective operation of the air conditioner.

It is also recommended to maintain the units once a year regularly when operating the air conditioner for a long time.

Check periodically signs of rust or scratches, etc. on coating of the outdoor units.

Repair the defective position or apply the rust resisting paint if necessary.

If an indoor unit operates for approx. 8 hours or more per day, usually it is necessary to clean the indoor/outdoor units once three months at least.

These cleaning and maintenance should be carried out by a qualified dealer.

Although the customer has to pay the charge for the maintenance, the life of the unit can be prolonged.

Failure to clean the indoor/outdoor units regularly will cause shortage of capacity, freezing, water leakage or trouble on the compressor.

### <Check list>

Part name	Object		Contents of check	Contents of maintenance
	Indoor	Outdoor		
Heat exchanger	✓	✓	• Blocking with dust, damage check	• Clean it when blocking is found.
Fan motor	✓	✓	• Audibility for sound	• When abnormal sound is heard
Filter	✓	—	• Visual check for dirt and breakage	• Clean with water if dirty • Replace if any breakage
Fan	✓	✓	• Visual check for swing and balance • Check adhesion of dust and external appearance.	• Replace fan when swinging or balance is remarkably poor. • If a large dust adheres, clean it with brush or water.
Suction/ Discharge grille	✓	—	• Visual check for dirt and scratch	• Repair or replace it if deformation or damage is found.
Drain pan	✓	—	• Check blocking by dust and dirt of drain water.	• Clean drain pan, Inclination check
Front panel, Louver	✓	—	• Check dirt and scratch.	• Cleaning/Coating with repair painting
External appearance	—	✓	• Check rust and peeling of insulator • Check peeling and floating of coating film	• Coating with repair painting

# 10. P.C. BOARD EXCHANGE PROCEDURES

## ■ Indoor unit

---

### 10-1. Replacement of indoor P.C. boards

#### <Note: when replacing the P.C. board for indoor unit servicing>

The nonvolatile memory (hereafter called EEPROM, IC503) on the indoor unit P.C. board before replacement includes the model specific type information and capacity codes as the factory-set value and the important setting data which have been automatically or manually set when the indoor unit is installed, such as system/indoor/group addresses, high ceiling select setting, etc.

When replacing the P.C. board for indoor unit servicing, follow the procedures below.

After replacement completes, confirm whether the settings are correct by checking the indoor unit No., Group header unit/follower unit settings and perform the cooling cycle confirmation through the trial operation.

#### <Replacement procedures>

#### **CASE 1**

**Before replacement, the indoor unit can be turned on and the setting data can be read out by wired remote control operation.**

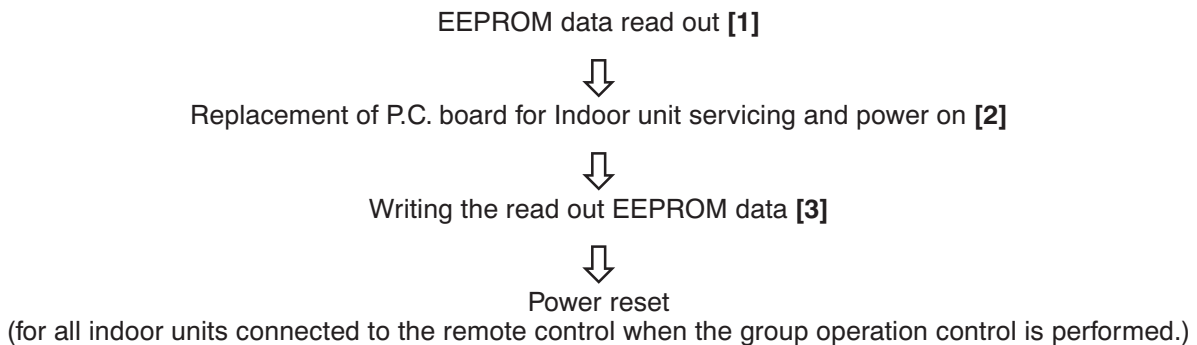

#### **CASE 2**

**The EEPROM before replacement is incomplete and the setting data cannot be read out.**

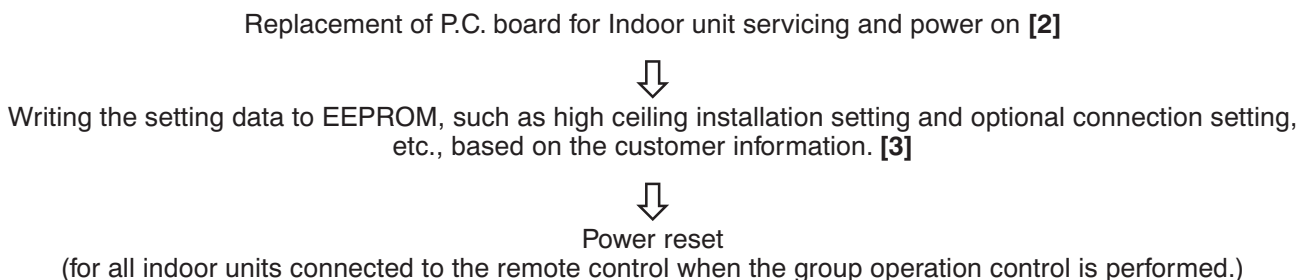

## [1] Setting data read out from EEPROM

The setting data modified on the site, other than factory-set value, stored in the EEPROM shall be read out.

### <RBC-ASCU11-\*>

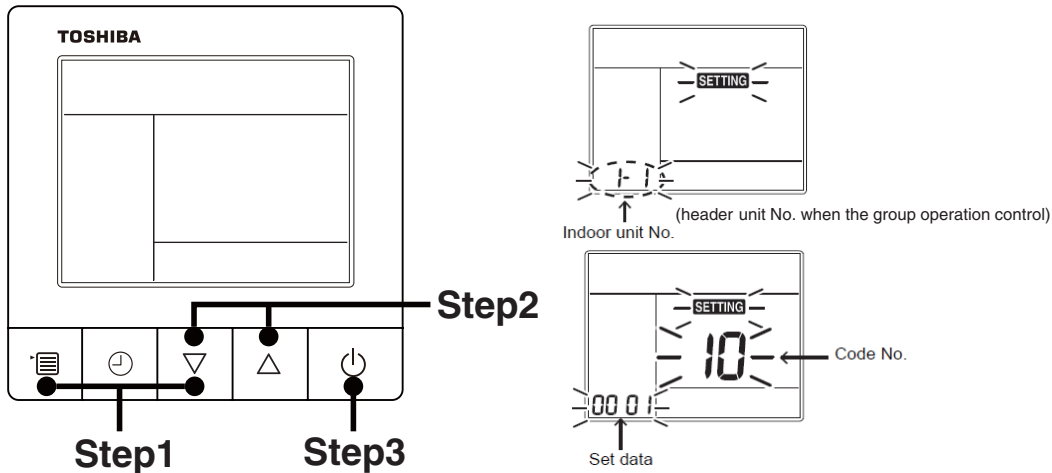

**Step 1** Push and hold the [menu + ▽] buttons at same time for more than 10 seconds.

\*When the group operation control is performed, the unit No. displayed for the first time is the header unit No.

At this time, the Code No. (DN) shows “10”. Also, the fan of the indoor unit selected starts its operation and the swing operation also starts if it has the louvers.

**Step 2** Every time when the [▽ or △] button is pushed, the indoor unit No. under the group control is displayed in order. Specify the indoor unit No. to be replaced.

1. Change the Code No. (DN) to 10 → 01 by pushing [▽ or △] buttons setting. (this is the setting for the filter sign lighting time.)

At this time, be sure to write down the setting data displayed.

2. Change the Code No. (DN) by pushing [▽ or △] buttons. Similarly, be sure to write down the setting data displayed.

3. Repeat the step 2-2 to set the other settings in the same way and write down the setting data as shown in the table 1 (example).

\* The Code No. (DN) are ranged from “01” to “FE”. The Code No. (DN) may skip.

### <RBC-AMT\*\*\*>

## [1] Setting data read out from EEPROM

The setting data modified on the site, other than factory-set value, stored in the EEPROM shall be read out.

**Step 1** Push  $\text{SET}$ ,  $\text{ON}$  and  $\text{TEST}$  button on the remote controller simultaneously for more than 4 seconds.

\*When the group operation control is performed, the unit No. displayed for the first time is the header unit No.

At this time, the CODE No. (DN) shows “ $\text{E}1$ ”. Also, the fan of the indoor unit selected starts its operation and the swing operation also starts if it has the louvers.

**Step 2** Every time when the  $\text{UNIT LOUVER}$  (left side button) button is pushed, the indoor unit No. under the group control is displayed in order. Specify the indoor unit No. to be replaced.

1. Change the CODE No. (DN) to  $\text{E}1 \rightarrow \text{E}2$  by pushing  $\text{DOWN} / \text{UP}$  buttons for the temperature setting. (this is the setting for the filter sign lighting time.)  
At this time, be sure to write down the setting data displayed.

2. Change the CODE No. (DN) by pushing  $\text{DOWN} / \text{UP}$  buttons for the temperature setting. Similarly, be sure to write down the setting data displayed.

3. Repeat the step 2-2 to set the other settings in the same way and write down the setting data as shown in the table 1 (example).

\* The CODE No. (DN) are ranged from “ $\text{E}1$ ” to “FE”. The CODE No. (DN) may skip.

**CODE No. required at least**

DN	Contents
10	Type
11	Indoor unit capacity
12	System address
13	Indoor unit address
14	Group address

1. The Code No. for the Indoor unit type and Indoor unit capacity are required to set the rotation number setting of the fan.
2. If the system/indoor/group addresses are different from those before replacement, the auto-address setting mode starts and the manual resetting may be required again.  
(when the multiple units group operation including twin system.)

**Step3** After writing down all setting data, push [ON/OFF] button to return to the normal stop status.  
(It takes approx. 1 min until the remote controller operation is available again.)

## [2] P.C. Board for indoor unit servicing replacement procedures (e.g. MCC-1643)

- Step1** Replace the P.C. board to the P.C. board for indoor unit servicing.  
At this time, perform the same setting of the jumper wire (J01, J08, J09) setting (cut), switch SW501, (short-circuit) connector CN34 as the setting of the P.C. board before replacement.

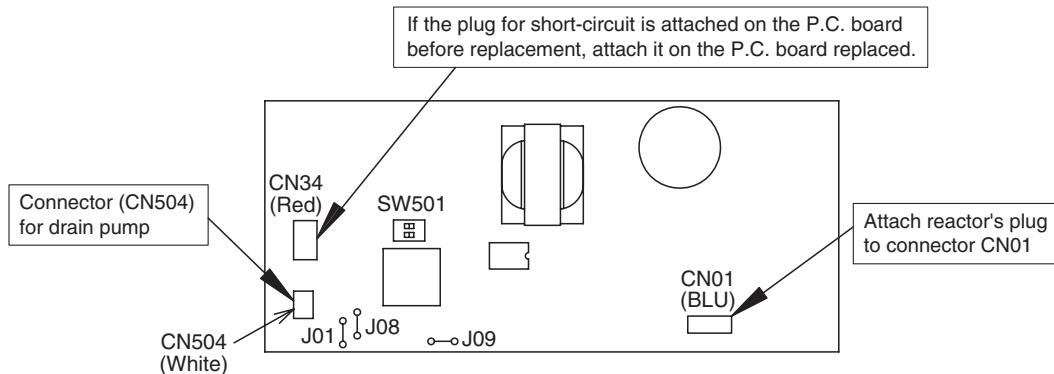

- Step2** It is necessary to set indoor unit to be exchanged: Remote controller = 1 : 1  
Based upon the system configuration, turn on power of the indoor unit with one of the following items.

- 1) Single (Individual) operation. Turn on power of the indoor units and proceed to [3].
- 2) Group operation
  - A) In case that power of the exchanged indoor unit only can be turned on  
Turn on power of the exchanger indoor unit only and proceed to [3].
  - B) In case that power of the indoor units cannot be turned on individually (Case 1)
    - a) Remove temporarily the group wire connected to the terminal blocks A and B of the indoor unit.
    - b) After connecting the remote controller wire only to the removed terminal block, turn on power of the indoor units and proceed to [3].
      - \* When the above methods cannot be used, follow to the two cases below.
  - C) In case that power of the indoor units cannot be turned in individually (Case 2)
    - a) Remove all CN41 connectors of the indoor units in the same group except those of the exchanged indoor unit.
    - b) Turn on power of the indoor units and proceed to [3].
      - \* After [3] operation has finished, be sure to return the temporarily removed group wire or CN41 connector to the original connection.

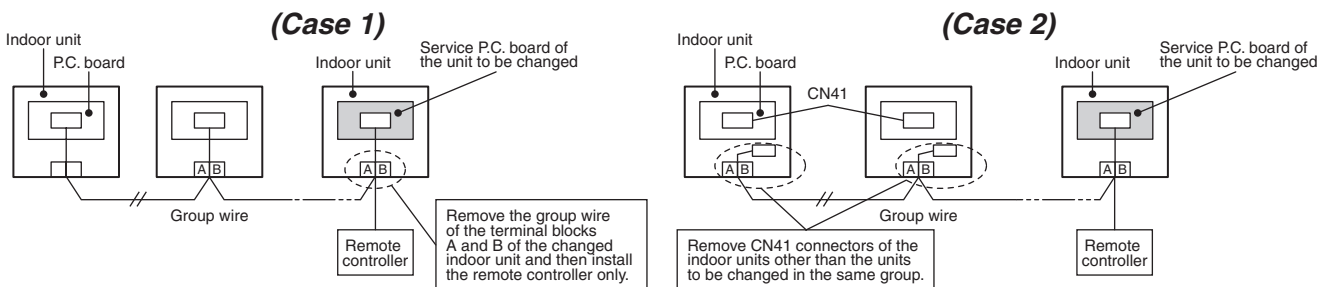

### [3] Writing the setting data to EEPROM

The settings stored in the EEPROM of the P.C. board for indoor unit servicing are the factory-set values.

#### <RBC-ASCU11-\*>

- Step 1** Push and hold the [menu + ▽] buttons at same time for more than 10 seconds.  
\*When the group operation control is performed, the unit No. displayed for the first time is the header unit No.  
At this time, the Code No. (DN) shows “10”. Also, the fan of the indoor unit selected starts its operation and the swing operation also starts if it has the louvers.
- Step 2** Every time when the [▽ or △] button is pushed, the indoor unit No. in the group control operation are displayed in order.  
(The settings stored in the EEPROM of the P.C. board for indoor unit servicing are the factory-set values.)  
Specify the indoor unit No. with its P.C. board replaced to the P.C. board for indoor unit servicing.  
(You cannot perform this operation if “ALL” is displayed.)
- Step 3** Select the Code No. (DN) can be selected by pushing the [▽ or △] button.  
• Set the indoor unit type and capacity.  
The factory-set values shall be written to the EEPROM by changing the type and capacity.
1. Push the [menu] button to make Code No. flash. And set the Code No. (DN) to 10 .
  2. Push the [menu] button to make SET DATA flash. And select the type by pushing the [•Ⓜ or •Ⓨ] buttons.  
(For example, 4-way Cassette Type is set to “0001”. Refer to table 2)
  3. Push [OFF timer] button.  
(The changed data is set.)
  4. Change the Code No. (DN) to “11” by pushing the [▽ or △] buttons.
  5. Select the capacity by pushing the [▽ or △] buttons.  
(For example, UP009 Type is set to “0003”. Refer to table 3)
  6. Push [OFF timer] button.  
(The changed data is set.)
- Step 4** Write the on-site setting data to the EEPROM, such as address setting, etc. Perform the steps 1 and 2 above again.
- Step 5** Change the Code No. (DN) to “01” by pushing the [▽ or △] buttons.  
(this is the setting for the filter sign lighting time.)
- Step 6** Check the setting data displayed at this time with the setting data put down in [1].
1. If the setting data is different, modify the setting data by pushing the [▽ or △] buttons to the data put down in [1].
  2. If the data is the same, proceed to next step.
- Step 7** Change the Code No. (DN) by pushing the [▽ or △] buttons.  
As described above, check the setting data and modify to the data put down in [1].
- Step 8** Repeat the steps 6 and 7.
- Step 9** After the setting completes, push the [ON/OFF] button to return to the normal stop status.  
(It takes approx. 1 min until the remote controller operation is available again.)



<RBC-AMT\*\*\*>

**Step 1** Push , and buttons on the remote controller simultaneously for more than 4 seconds.

\* In the group control operation, the unit No. displayed for the first time is the header unit No.  
At this time, the CODE No. (DN) shows “ ”. Also, the fan of the indoor unit selected starts its operation and the swing operation starts if it has the louvers.

(The unit No. “ ” is displayed if the auto-address setting mode is interrupted in [2] step 2 a))

**Step 2** Every time when (left side button) button is pushed, the indoor unit No. in the group control operation are displayed in order.  
(The settings stored in the EEPROM of the P.C. board for indoor unit servicing are the factory-set values.)

Specify the indoor unit No. with its P.C. board replaced to the P.C. board for indoor unit servicing.  
(You cannot perform this operation if “ ” is displayed.)

**Step 3** Select the CODE No. (DN) can be selected by pushing the / button for the temperature setting.

• Set the indoor unit type and capacity.  
The factory-set values shall be written to the EEPROM by changing the type and capacity.

1. Set the CODE No. (DN) to . (without change)
2. Select the type by pushing / buttons for the timer setting.  
(For example, 4-way Cassette Type is set to “ ”. Refer to table 2)
3. Push button.  
(The operation completes if the setting data is displayed.)
4. Change the CODE No. (DN) to “ ” by pushing / buttons for the temperature setting.
5. Select the capacity by pushing / buttons for the timer setting.  
(For example, UP018 Type is set to “ ”. Refer to table 3)
6. Push button.  
(The setting completes if the setting data are displayed.)

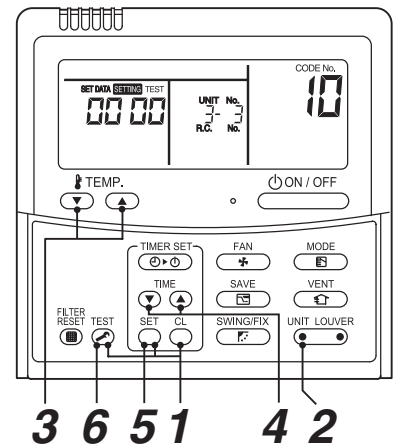

**Step 4** Write the on-site setting data to the EEPROM, such as address setting, etc. Perform the steps 1 and 2 above again.

**Step 5** Change the CODE No. (DN) to “ ” by pushing / buttons for the temperature setting.  
(this is the setting for the filter sign lighting time.)

**Step 6** Check the setting data displayed at this time with the setting data put down in [1].

1. If the setting data is different, modify the setting data by pushing / buttons for the timer setting to the data put down in [1].  
The operation completes if the setting data is displayed.

2. If the data is the same, proceed to next step.

**Step 7** Change the CODE No. (DN) by pushing / buttons for the temperature setting.  
As described above, check the setting data and modify to the data put down in [1].

**Step 8** Repeat the steps 6 and 7.

**Step 9** After the setting completes, push button to return to the normal stop status.  
(It takes approx. 1 min until the remote controller operation is available again.)

\* The CODE No. (DN) are ranged from “ ” to “ ”. The CODE No. (DN) is not limited to be serial No.

Even after modifying the data wrongly and pushing button, it is possible to return to the data before modification by pushing button if the CODE No. (DN) is not changed.

**Table 1. Setting data (CODE No. table (example))**

CODE No. (DN)	Item	Setting data	Factory-set value
01	Filter sign lighting time		Depending on Type
02	Filter pollution level		0000: standard
03	Central control address		0099: Not determined
06	Heating suction temperature shift		Depending on Type
0F	Cooling only		0000: Heat pump
10	Type		Depending on model type
11	Indoor unit capacity		Depending on capacity type
12	System address		0099: Not determined
13	Indoor unit address		0099: Not determined
14	Group address		0099: Not determined
19	Louver type (wind direction adjustment)		Depending on Type.
1E	Temperature range of cooling/heating automatic SW control point		0003: 3 deg (Ts ±1.5)
28	Power failure automatic recovery		0000: None
2b	Thermostat output SW (T10 ③)		0000: Thermostat ON
31	Ventilation fan (standalone)		0000: Not available
32	Sensor SW (Selection of static pressure)		0000: Indoor unit sensor
5d	High ceiling SW		0000: Standard
60	Timer setting (wired remote controller)		0000: Available
77	Dual set point		0000: Unavailable
b3	Soft cooling		0001: Available
b5	Occupancy sensor: Provided/None		0000: None
b6	Occupancy sensor: Enable/Invalid (Judgment time of absence)		0002: Enable (60 min.)
b7	Occupancy sensor: Operation at absent time		0000: Stand by
d0	Remote controller operation save function		0001: Enable
F0	Swing mode		0001: Standard
F1	Louver fixing position (Flap No. 1)		0000: Not fixed
F2	Louver fixing position (Flap No. 2)		0000: Not fixed
F3	Louver fixing position (Flap No. 3)		0000: Not fixed
F4	Louver fixing position (Flap No. 4)		0000: Not fixed
F6	Presence of Application control kit		0000: None
Fd	Priority operation mode (FS unit)		0000: Heating
FE	FS unit address		0099: Unfixed

**Table 2. Type: Code No.10**

Setting data	Type	Model name
0000	1-way cassette	MMU-UP***SH*
0002	2-way cassette	MMU-UP***WH*
0010	Floor standing cabinet	MML-UP***H*
0011	Floor standing concealed	MML-UP***BH*
0013	Floor standing type	MMF-UP***H
0014	Compact 4-way cassette	MMU-UP***MH*

**Table 3. Indoor unit capacity: Code No.11**

Setting data	Model	Setting data	Model
0000*	Invalid	0009	018 type
0044	003 type	0011	024 type
0041	005 type	0012	027 type
0001	007 type	0015	036 type
0003	009 type	0017	048 type
0005	012 type	0018	056 type
0007	015 type		

# 11. DETACHMENTS

## 11-1. Compact 4-way cassette



MMU-UP\*\*\*\*MH\*

### WARNING

Be sure to stop operation of the air conditioner before work and then turn off switch of the breaker.

### CAUTION

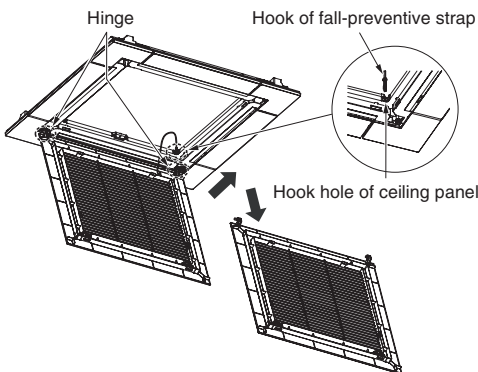
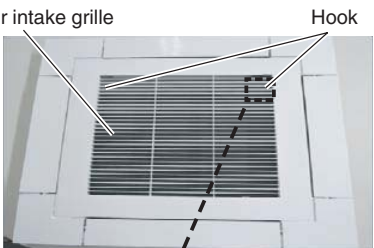
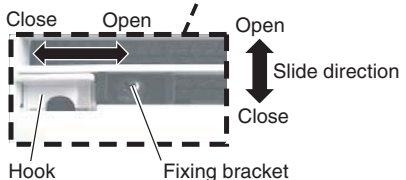
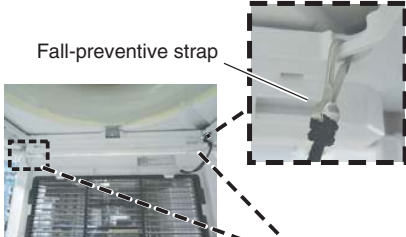
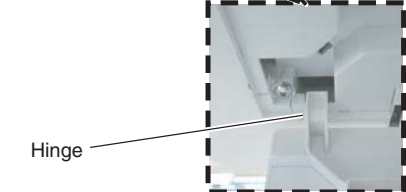
Be sure to put on gloves during working time; otherwise an injury will be caused by a part etc.

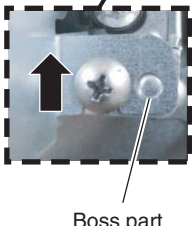

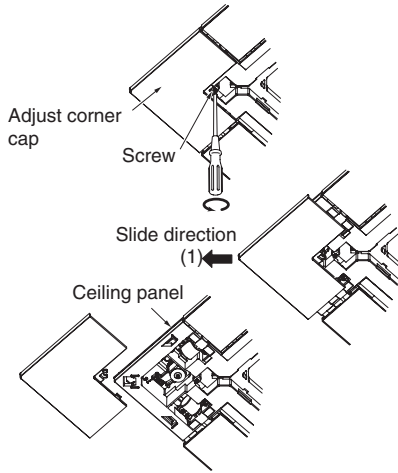
No.	Part name	Procedure	Remarks
①	Air intake grille	<p><b>1. Detachment</b></p> <ol style="list-style-type: none"> <li>1) Stop operation of the air conditioner and then turn off switch of the circuit breaker.</li> <li>2) Loosen the fixing screw. And slide the fixing bracket toward the inside. (M 4 × 8, 1 pcs.)</li> <li>3) Holding the air intake grille, slide the hook in the direction of the arrow and slowly open the grille.</li> <li>4) Remove the hook of the fall-preventive strap from the ceiling panel. Remove the hinge section of the air intake grille from the ceiling panel while the air intake grille is opened.</li> </ol> <p><b>2. Attachment</b></p> <ol style="list-style-type: none"> <li>1) Hook the hinge of the air intake grille to the main panel, and then attach the fall-preventive strap.</li> <li>2) Close the air intake grille, and then slide the hook.</li> <li>3) Slide the grille fixing bracket to fix it with the screws. (M 4 × 8, 1 pc.)</li> </ol> 	   
②	Electric parts cover	<p><b>1. Detachment</b></p> <ol style="list-style-type: none"> <li>1) Loosen the fixing screws (2 places) of the electric parts cover. (M 4 × 8, 2 pcs.)</li> <li>2) Slide the electric parts cover toward upper side to remove it.</li> </ol> <p><b>2. Attachment</b></p> <ol style="list-style-type: none"> <li>1) Slide the electric parts cover to attach it. (Arrange the boss at the electric parts side just on the boss hole at the cover side.)</li> <li>2) Tighten the screws of the electric parts cover (2 positions) to fix it. (M 4 × 8, 2 pcs.)</li> </ol>	  

No.	Part name	Procedure	Remarks
③	Adjust corner cap	<p><b>1. Detachment</b></p> <ol style="list-style-type: none"> <li>1) Remove the air intake grille. (Refer to 1 of ①.)</li> <li>2) Loosen the fixing screws on the adjust corner cap. (M 4 × 12, 4 pcs.)</li> <li>3) Slide the adjust corner cap to outside to remove it.</li> </ol> <p><b>2. Attachment</b></p> <ol style="list-style-type: none"> <li>1) Matching claws (5 positions) of the adjust corner cap to holes of the panel main unit holes and attach them.</li> <li>2) Tighten the fixing screws of the adjust corner cap (M 4 × 12, 4 pcs.).</li> </ol> <p><b>NOTE</b></p> <p>Tighten the screw with a hand screwdriver and do not use a tool such as a electric screwdriver. Tightening torque : 1 N•m or less</p>	
④	Ceiling panel	<p><b>1. Detachment</b></p> <ol style="list-style-type: none"> <li>1) Remove the air intake grille and the adjust corner cap. (Refer to 1 of ① and 1 of ③.)</li> <li>2) Remove the louver motor connector.</li> <li>3) By sliding the panel fixing bracket of the corner part, remove it from the fixing screws. (Total 4 positions)</li> <li>4) Push the tentative hanging hook at the center part of the ceiling panel main body toward the outside of the ceiling panel, and then remove the ceiling panel from the indoor unit.</li> </ol> <p><b>2. Attachment</b></p> <ol style="list-style-type: none"> <li>1) Match the louver motor connector of the ceiling panel so that it directs to the electric parts side, and then hook the tentative hanging hook at the center part of the ceiling panel main body to the bell mouth.</li> <li>2) Connect the louver motor connectors at the ceiling panel side and the indoor unit side.</li> <li>3) Lift up the panel corner part and put out the screw head of the panel fixed implement. Slide the panel fixed bracket, and then fix the indoor unit and the ceiling panel. (Total 4 positions). * In case of loosening screws of the panel fixed implement so that screw head is out under the panel fixed implement, retighten the screws after work.</li> <li>4) Following to the works in items ③-2 and ①-2, attach the adjust corner cap and the air intake grille as original.</li> </ol> <p><b>NOTE</b></p> <ul style="list-style-type: none"> <li>• The ceiling panel aligns directionally with the indoor unit. Check that the lead wires of louver motor connector are on the electrical control box side.</li> <li>• When a clearance is found between the ceiling surface and the ceiling panel, readjust height of the indoor unit even if the screws have been tightened.</li> </ul>	

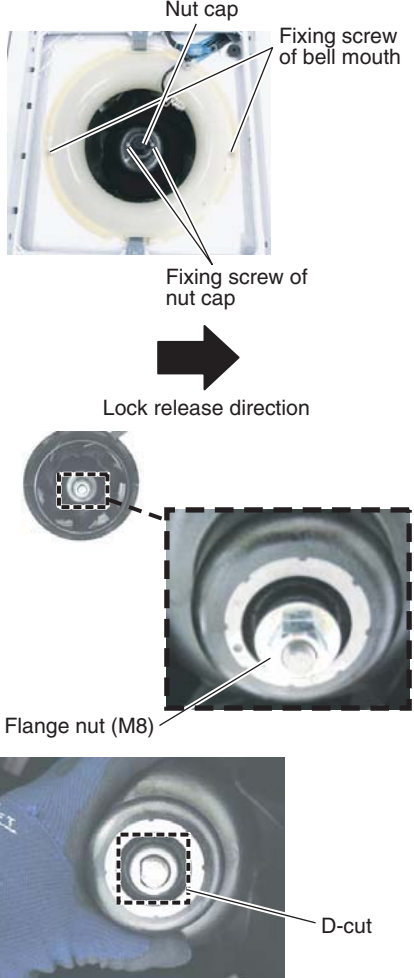
No.	Part name	Procedure	Remarks
⑤	Control P.C. board	<p><b>1. Detachment</b></p> <ol style="list-style-type: none"> <li>1) Remove the electric parts cover. (Refer to 1 of ②)</li> <li>2) Remove connectors which are connected from the control P.C. board to the other parts and then remove wiring from the clamp.</li> </ol> <p><b>NOTE</b></p> <hr/> <p>Unlock the lock of the housing part and then remove the connector.</p> <hr/> <p>CN34 : Float switch (3P, Red)  CN41 : Remote controller (2P, Blue)  CN40 : Control wires (2P, Blue)  CN67 : Power supply wires (5P, Black)  CN100 : TC1 sensor (3P, Brown)  CN101 : TC2 sensor (2P, Black)  CN102 : TCJ sensor (2P, Red)  CN104 : Room temp. (TA) sensor (2P, Yellow)  CN82 : PMV (6P, Blue)  CN510 : Louver motor (20P, White)  CN504 : Drain pump (2P, White)  CN210 : Fan motor (7P, White)  CN22 : Earth wire (Tab terminal)</p> <ol style="list-style-type: none"> <li>3) Unlock the locks of the card edge spacer (4 positions) and remove the control P. C. board.</li> </ol> <p><b>2. Attachment</b></p> <ol style="list-style-type: none"> <li>1) Fix the control board to the card edge spacer (4 positions).</li> <li>2) Connect the removed connectors as original, which were unconnected in item 1. Detachment, and fix the wires with clamps.</li> <li>3) Following to the work in ②-2, attach the electric parts covers as original.</li> </ol>	<p>Clamp</p>  <p>Clamp</p> <p>Card edge spacer</p>



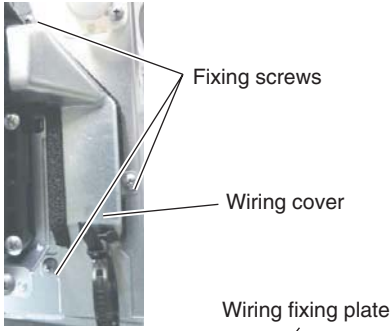
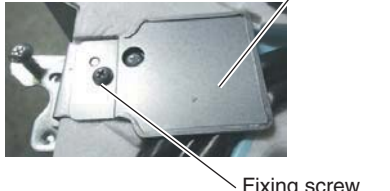
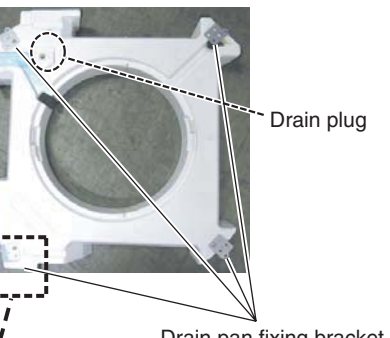

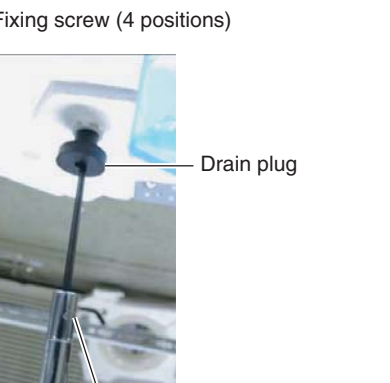
No.	Part name	Procedure	Remarks
⑤	Turbo fan	<p><b>1. Detachment</b></p> <ol style="list-style-type: none"> <li>1) Remove the air intake grille. (Refer to 1 of ①.)</li> <li>2) Loosen the fix screws (2 positions) of the bell mouth, rotate the bell mouth, and then take off it. (M 4 × 10, 2 pcs.)</li> <li>3) Remove the screw which is fixing the nut cap and then remove the nut cap. (M4 × 10, 2 pcs.)</li> <li>4) Loosen the flange nut (M8) at the center part of the turbo fan, and then take off (Counter clockwise) * Supporting with hands, take off the turbo fan so that it will not fall down.</li> </ol> <p><b>NOTE</b></p> <hr/> <p>Use a box wrench for attachment and detachment of the turbo fan. If using adjustable wrench etc., the other parts may be damaged in work.</p> <hr/> <p><b>2. Attachment</b></p> <ol style="list-style-type: none"> <li>1) Match the D-cut of the motor shaft with the boss part D-cut of the turbo fan, and then insert the turbo fan into the motor shaft.</li> <li>2) Tighten M8 nut with flange. (Tightening torque of the turbo fan: 5.4+0.5, -0.2N•m)</li> <li>3) Attach a nut cap as original.</li> <li>4) Slide the Bell mouth removed in item 1-2) and attach it then fix it with screws. (M 4 × 10, 2 pcs.).</li> <li>5) Following to the work in item ①-2, attach the air intake grille as original.</li> </ol> <p><b>NOTE</b></p> <hr/> <p>(Tightening torque of the turbo fan: 5.4 (+0.5, -0.2)N•m)</p> <hr/>	 <p>Nut cap</p> <p>Fixing screw of bell mouth</p> <p>Fixing screw of nut cap</p> <p>Lock release direction</p> <p>Flange nut (M8)</p> <p>D-cut</p>

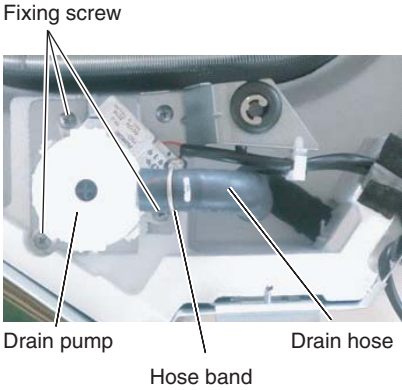
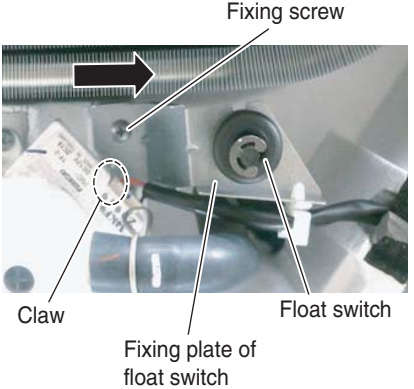



No.	Part name	Procedure	Remarks
⑦	Drain pan	<p><b>1. Detachment</b></p> <ol style="list-style-type: none"> <li>Remove the ceiling panel and the electrical parts covers. (Refer to items ④-1 and ②-1.)</li> <li>Remove the wiring cover. (Fixing screw M 4 × 8, 3pcs.)</li> <li>Remove the wiring fixing plate. (Fixing screw M 4 × 8, 1pc.)</li> <li>Remove the connectors of the fan motor lead wire, louver motor lead wire, and room temperature (TA) sensor from the control P.C. board, and then remove the wiring from the clamp. * Pull out the wires from the hole at the side face of the electric parts. CN210: Fan motor (7P, White) CN510: Louver motor lead wire (20P, White) CN104: TA (Room temperature) sensor (2P, Yellow)</li> <li>Remove the drain plug of the drain pan, and extract the stayed drain water. * Be careful that water is extracted at a stretch when taking off the drain plug. * When taking off the drain plug, be sure to prepare a bucket, etc. for spilled water.</li> <li>Remove the fixing screws of the drain pan fixing bracket. (M 4 × 8, 4 pcs.)</li> <li>Using the both hands, hold the water-spilling port part of the drain pan and then slowly pull out the foaming parts firstly. * As there is remained water in the drain pan, clear it carefully.</li> </ol> <p><b>2. Attachment</b></p> <ol style="list-style-type: none"> <li>Arrange direction of the drain pan directly to the foaming parts and insert it. * Pass the fan motor lead wire through the inner side of the drain pan.</li> <li>Attach the fixing screws of the drain pan fixing bracket which was taken off in item 1-6). (M 4 × 12, 4 pcs.)</li> <li>Insert the drain plug. (Put the tool with thin top in the hole of the drain plug, and then push the plug in.)</li> <li>Perform wiring works to original arrangement, wiring of the fan motor, louver motor lead wires, and the room temperature (TA) sensor, and then attach the wiring fixing bracket and the wiring cover.</li> <li>Following to works in items ④-2 and ②-2, attach the panel, electric parts cover as original.</li> </ol>	     <p>Push in the drain plug with the thin tip tool.</p>

No.	Part name	Procedure	Remarks
⑧	Drain pump	<p><b>1. Detachment</b></p> <ol style="list-style-type: none"> <li>1) Remove the drain pan. (Refer to ⑦-1.)</li> <li>2) Remove the drain pump connector (CN504: 2P, White) connected to the control P.C. board and remove the lead wires from the clamp.</li> <li>3) Remove the fixing screws to remove the drain pump. (M 4 × 10, 3 pcs.)</li> <li>4) Move the knob of the hose band which fixes the drain hose a little from pump connecting part to the hose side, and then remove the drain hose from the drain pump. * Be careful that water may be out.</li> </ol> <p><b>2. Attachment</b></p> <ol style="list-style-type: none"> <li>1) Confirm the direction of the drain pump, and then fix it with screws. (M 4 × 10, 3 pcs.)</li> <li>2) Connect the drain hose to the drain pump. * For the drain hose, insert up to the root of the connecting part. * Attach a band to the marked position of the hose, and the knob of a hose band is attached to the deep side of a set.</li> <li>3) Pass the drain pump wiring through side plate and clamp, and then connect the connector to the control P.C. board.</li> <li>4) Following to work in ⑦-2, attach the drain pan, panel, and electrical parts covers as original.</li> </ol>	 <p>The diagram shows a close-up of the drain pump assembly. A white connector is visible, secured by three screws. A blue drain hose is connected to the pump. A black hose band is used to secure the hose to the pump housing. Labels with leader lines point to the 'Fixing screw', 'Drain pump', 'Drain hose', and 'Hose band'.</p>
⑨	Float switch	<p><b>1. Detachment</b></p> <ol style="list-style-type: none"> <li>1) Remove the drain pan. (Refer to ⑦-1.)</li> <li>2) Remove the float switch connector (CN34 3P, Red) connected to the control P.C. board, and then take off the lead wires from the clamp.</li> <li>3) Remove the screws which fix the float switch. (M 4 × 8, 1 pc.)</li> <li>4) Slide the float switch fixed bracket as direction shown in the right figure, and then take off it from the claw.</li> </ol> <p><b>2. Attachment</b></p> <ol style="list-style-type: none"> <li>1) Insert the float switch fixing plate into the claw, and tighten the fixing screw.</li> <li>2) Pass the float switch lead wires through the side plate and the clamp, and then connect the connector to the control P.C. board.</li> <li>3) Following to work in ⑦-2, attach the covers of the drain pan, panel, and electric parts box as original.</li> </ol>	 <p>The diagram shows the float switch assembly. A red connector is visible. A white float switch is mounted on a bracket. A black arrow indicates the direction to slide the bracket. A white fixing plate is attached to the bracket with a screw. Labels with leader lines point to the 'Fixing screw', 'Claw', 'Fixing plate of float switch', and 'Float switch'.</p>

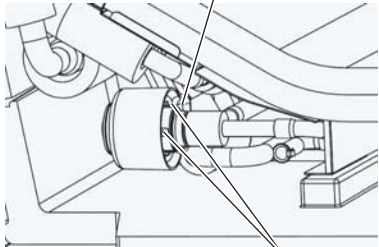

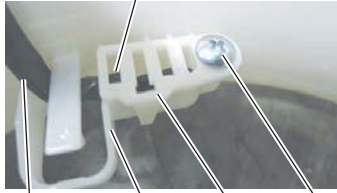
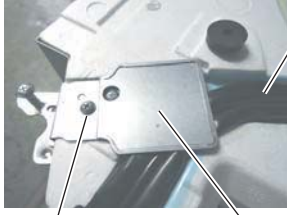
No.	Part name	Procedure	Remarks
⑩	Fan motor	<p><b>1. Detachment</b></p> <ol style="list-style-type: none"> <li>1) Remove the turbo fan, electric parts cover, wiring cover and wiring fixing plate. (Refer to ⑥-1, ②-1, ⑦-1-2, ⑦-1-3.)</li> <li>2) Remove the fan motor connector (CN210, White, 7P) connected to the control P.C. board, and then take off the lead wires from the clamp.</li> <li>3) Remove the shoulder screws (Black, 2pcs.) of the motor lead wiring cover, and separate the lead wires and the lead wire cover.</li> <li>4) Remove the hexagon nuts (M6) which fix the motor, and the washers. (3 pcs. Each). * When taking off them, hold them with a hand so that motor will not fall down.</li> <li>5) Remove the motor with rubber cushion from the bolt.</li> </ol> <p><b>2. Attachment</b></p> <ol style="list-style-type: none"> <li>1) Pass rubber cushion of the motor in the bolt, put the washer and the hexagon nut in this order, and then tighten to fix them. (Tightening torque: <math>4.9 \pm 0.5N \cdot m</math>)</li> <li>2) Pass the lead wire through the motor lead wire fixing plate removed in 1-3), and then fix it with shoulder screw.</li> <li>3) Perform wiring of the motor lead wires as original, connect the connector to the control P.C. board, and then attach the wiring fixing plate and the wiring cover.</li> <li>4) Following to works in ⑥-2 and ②-2, attach the turbo fan and the electric parts covers.</li> </ol>	  
⑪	PMV coil	<p><b>1. Detachment</b></p> <ol style="list-style-type: none"> <li>1) Remove the drain pan. (Refer to ⑦-1)</li> <li>2) Remove the PMV connectors (CN82, Blue, 6pcs.) connected to the control P.C. board, and take off the lead wires from the clamp.</li> <li>3) A little PMV coil is rotated, pressing down so that a PMV body may not turn, and it removes in the direction of an arrow.</li> </ol> <p><b>2. Attachment</b></p> <ol style="list-style-type: none"> <li>1) Attach the PMV coil as original.</li> </ol> <p><b>NOTE</b></p> <p>Be careful of direction of a PMV coil. Check that four projections of the fixed claw of PMV coil and PMV body have fitted in.</p>	 <p>The lead wire of PMV coil is turned in the top plate direction.</p>  <p>PMV coil fixed claw</p>

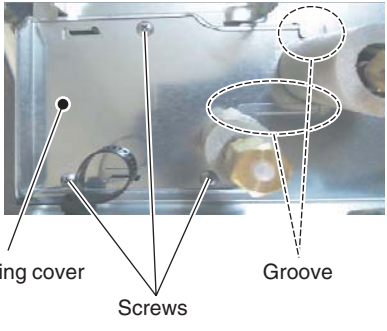
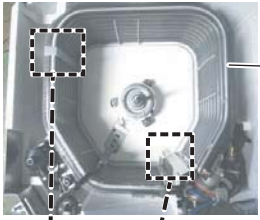
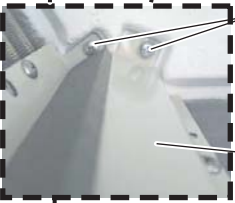
No.	Part name	Procedure	Remarks
⑫	TC1 TC2 TCJ Sensor	<p><b>1. Detachment</b></p> <ol style="list-style-type: none"> <li>1) Remove the drain pan. (Refer to ⑦-1.)</li> <li>2) Pull out the sensor to be exchanged from the sensor holder.</li> <li>3) Remove the connector connected to the control P.C. board, and take off wires from the clamp. (Refer to ⑤.)</li> </ol> <p><b>2. Attachment</b></p> <ol style="list-style-type: none"> <li>1) Insert the sensor to be exchanged into the specified sensor. (Refer to the right figure.)</li> <li>2) Perform wiring of the sensor as original.</li> </ol>	 <p>TC1 sensor (Blue)    TC2 sensor (Black)</p> <p>TCJ sensor (Red)</p>
⑬	TA sensor	<p><b>1. Detachment</b></p> <ol style="list-style-type: none"> <li>1) Remove the panel, electric parts box cover, wiring cover and wiring fixing plate. (Refer to ④-1, ②-1, ⑦-1-2, ⑦-1-3.)</li> <li>2) Disconnect TA sensor connector (CN104 Yellow, 2P) which is connected to the control P.C. board, and take off the lead wire from the clamp.</li> <li>3) Remove the screw of the TA sensor cover. (M 4 × 10, 1pc.)</li> <li>4) Remove TA sensor from the TA sensor fixing bracket.</li> </ol> <p><b>2. Attachment</b></p> <ol style="list-style-type: none"> <li>1) Fix TA sensor to TA sensor fixing bracket, and fix the TA sensor cover with screw. (M 4 × 10, 1 pc.)</li> <li>2) Perform wiring of TA sensor as original.</li> </ol>	<p>Adjust position of the tube so that the tube of TA sensor will be included in the cover.</p>  <p>TA sensor    TA sensor fixing bracket    Fixing screw    TA sensor cover</p> <p>Groove for wiring of the drain pan</p>  <p>Fixing screw    Wiring fixing plate</p>

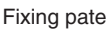
No.	Part name	Procedure	Remarks
⑭	Heat exchanger	<p><b>1. Detachment</b></p> <ol style="list-style-type: none"> <li>1) Recover refrigerant gas.</li> <li>2) Remove the refrigerant pipe at indoor unit side.</li> <li>3) Remove the drain pan. (Refer ⑦-1.)</li> <li>4) Disconnect the heat exchanger sensor (TC1, TC2, TCJ), PMV lead wires connectors from the control P.C. board, and then remove their lead wires from the clamp. (Refer to ⑤-1.)</li> <li>5) Remove the fixing screws of the piping cover and take off the piping cover. (M 4 × 8, 3 pcs.)</li> <li>6) Remove the shoulder screws of the separate plate (2 positions) and fixing plate (1 position), and then remove the heat exchanger. (3 shoulder screws)</li> </ol> <p><b>NOTE</b></p> <hr/> <p>* Supporting with a hand, remove the heat exchanger so that it will not be fallen down.</p> <p>* Take note that you will not get hurt by touching to Aluminum fin. Be sure to put on the protective gloves and the safety working clothing.</p> <hr/> <p><b>2. Attachment</b></p> <ol style="list-style-type: none"> <li>1) Attach the heat exchanger as original with the separate plate and the fixing plate.</li> <li>2) Slide the piping cover to the groove, fix it to the side plate, and then use the screws. (M 4 × 8, 3 pcs.)</li> <li>3) Perform wiring of the sensor and PMV lead wires as original.</li> <li>4) Connect the refrigerant pipe as before and then apply vacuuming.</li> <li>5) Following to the work in ⑦-2, attach the parts as original.</li> </ol>	     
<b>NOTE</b>			<hr/> <p>After assembling, check if that there is no abnormal sound, vibration, or puncture. Check the exchange point when you have a problem.</p> <hr/>

## 11-2. 2-way cassette

MMU-UP\*\*\*\*WH\*

### WARNING

Be sure to stop operation of the air conditioner before work and then turn off switch of the breaker.

### CAUTION

Be sure to put on gloves during working time; otherwise an injury will be caused by a part etc.



### Ceiling Panel (RBC-UW283PG(W)-E, UW803PG(W)-E, UW1403PG(W)-E)

For detachment, they are expediently expressed as follows:

UP009: MMU-UP0071WH to UP0151WH (Ceiling panel: RBC-UW283PG(W)-E)

UP027: MMU-UP0181WH to UP0301WH (Ceiling panel: RBC-UW803PG(W)-E)

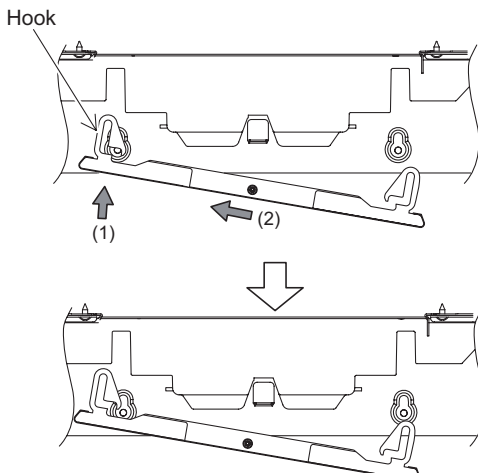
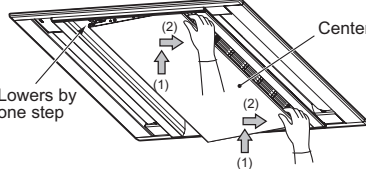
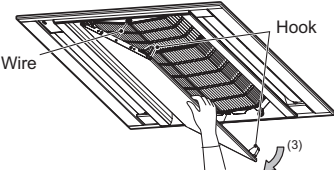
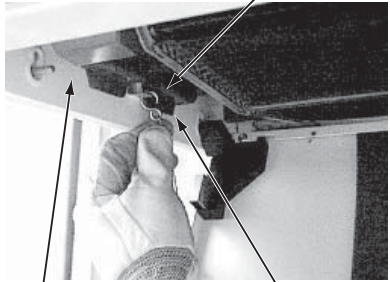
UP048: MMU-UP0361WH to UP0561WH (Ceiling panel: RBC-UW1403PG(W)-E)

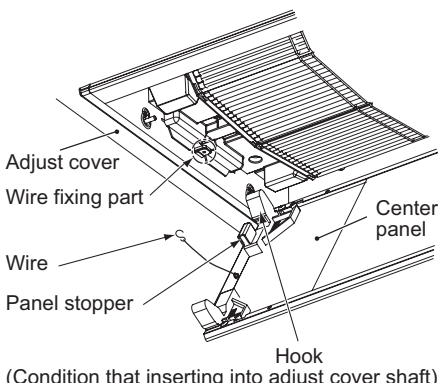
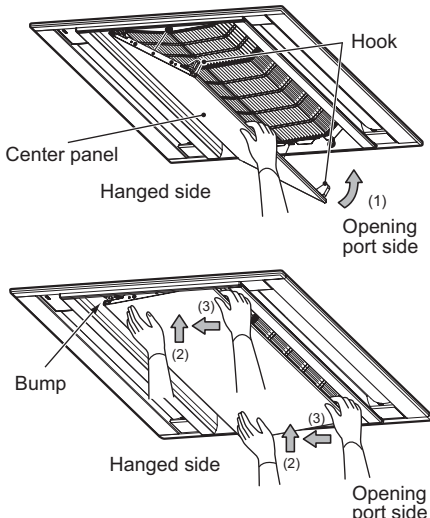
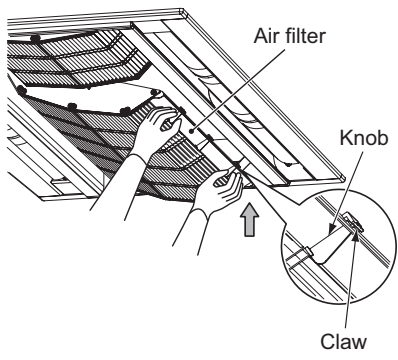

No.	Part name	Procedure	Remarks
①	Center panel	<p><b>1. Detachment</b></p> <ol style="list-style-type: none"> <li>1) Stop operation of the air conditioner and then turn off the breaker switch.</li> <li>2) Remove the center panel as the following procedure. The direction to open the center panel is beforehand decided. The opening side is the moving side when pushing edge of the center panel upward, and the side which does not practically move is the hanging side. <ul style="list-style-type: none"> <li>• While pushing edge (1) of opening port side of the center panel, pull it to the opening port side (2) .</li> <li>• When pulling the panel, the hanging side lowers by one step and the hook at opening port side is removed.</li> <li>* Hold the positions near the hook at both sides of the center panel, and remove hooks at opening port sides one by one.</li> <li>• Confirm that hanging sides at both sides lowered by one step, turn it downward slowly (3) and open the center panel.</li> <li>* Open the center panel until there is no slackness on the wire at both sides.</li> </ul> </li> <li>3) Take off the wire from fixing part of wire on the adjust cover.</li> <li>4) While lifting up the center panel (1) upward, slide it to the hanged direction (2) . The hook is removed.</li> </ol> 	   

No.	Part name	Procedure	Remarks
①	Center panel (Continued)	<p><b>2. Attachment</b></p> <p>1) Insert hook of the center panel into shaft of the adjust cover. (2 positions at left and right sides) Insert hook attached with a panel stopper.</p> <p><b>Note</b></p> <p>Be sure to attach a hook with panel stopper at first. If attaching a hook without panel stopper at first, the center panel cannot be attached.</p> <p>2) Hang S-shape bracket of the wire to the wire fixing part from down side.</p> <p><b>Note</b></p> <p>If hanging it from upside, the bracket may come off when opening/closing of the center panel. The wire is provided to prevent falling of the center panel. Be sure to attach it to the wire fixing part.</p>	
		<p>3) Turn the center panel slowly to (1) direction and then close it.</p> <p>4) Under condition that opening port side of the center panel closes, lift up the bump at hanged side (2) and then slide it to (3) hanged side to fix it. Hold the positions near the hooks at both sides of the center panel, and fix it to the unit one by one.</p>	
②	Air filter	<p><b>1. Detachment</b></p> <p>1) Perform work Detachment 1 of ①.</p> <p>2) Hold knob of the air filter, pull it downward while pushing it slantingly upward and then remove claws from frame of the center panel.</p> <p><b>2. Attachment</b></p> <p>1) Enter the air filter until it hits the back end of the frame of one side. Hold another knob, lift up the air filter until it hits the back, and leave the knob to attach the air filter.</p>	

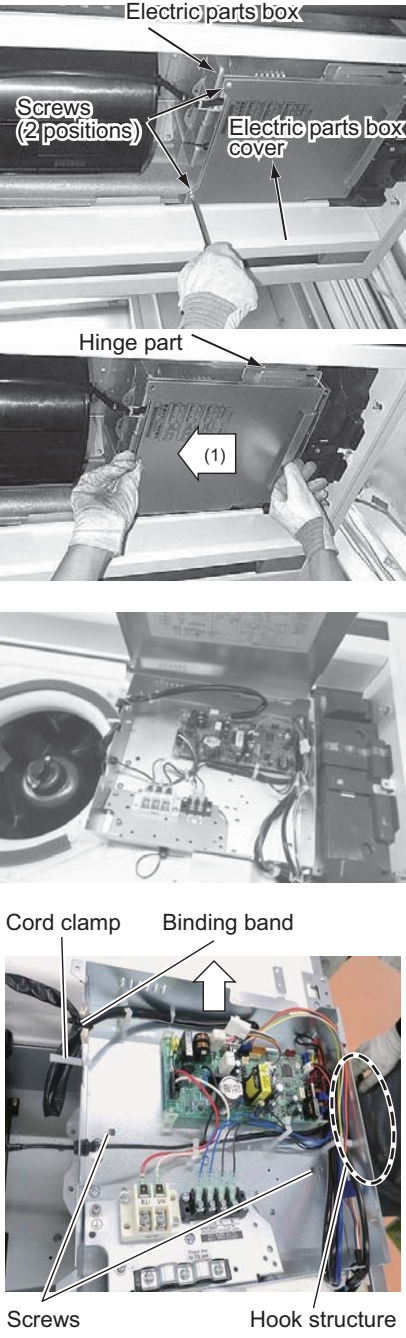

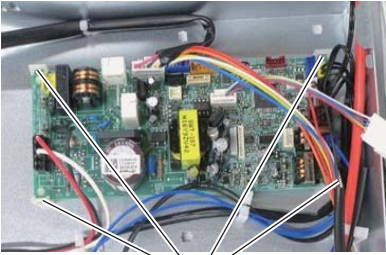
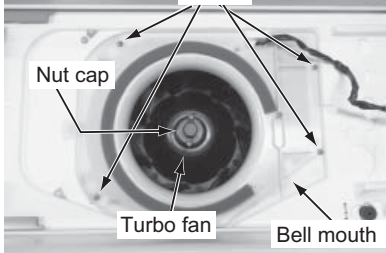
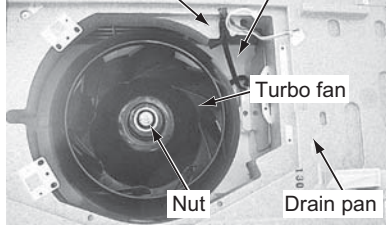
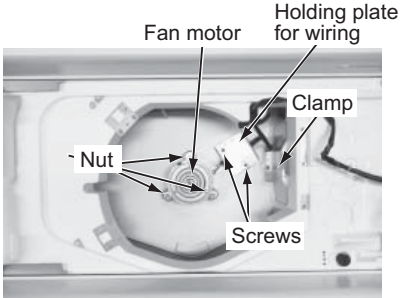
No.	Part name	Procedure	Remarks
③	Electric parts box	<p><b>1. Detachment</b></p> <ol style="list-style-type: none"> <li>1) Perform work Detachment 1 of ②.</li> <li>2) Take off screws. (M 4 × 8, 2 pcs.)</li> <li>3) When sliding the box to the arrow direction (1) in the figure, the electric parts box cover opens at the hinge part as the axis.</li> <li>4) Remove indoor/outdoor connecting wire and remote controller wiring from each terminal block.</li> <li>5) Remove the connectors connected from the control P.C. board to other parts.</li> </ol> <p><b>Note</b></p> <hr/> <p>Before removing the connectors, unlock the lock of housing part.</p> <hr/> <p>CN510 : Louver motor (20P: White)  CN34 : Float switch (3P: Red)  CN41 : Remote controller terminal block (3P: Blue)  (Terminal block screws: 4P)  CN504 : Drain pump (2P: White)  CN67 : Power supply terminal block (5P: Black)  (Terminal block screws: 2P)  CN82: PMV (6P: Blue)  CN100 : TC1 sensor (3P: Brown)  CN101 : TC2 sensor (2P: Black)  CN102 : TCJ sensor (2P: Red)  CN104 : Room temp. sensor (2P: Yellow)  CN210 : Fan motor (7P: White)</p> <ol style="list-style-type: none"> <li>6) Remove the binding band which is fixing the fan motor lead.</li> <li>7) Take off screws in the electric parts box. (M 4 × 8, 2 pcs.)</li> <li>8) The hanging structure is set at the side of the electric parts box. Remove the electric parts box by sliding it to the arrow mark in the figure.</li> </ol> <p><b>2. Attachment</b></p> <ol style="list-style-type: none"> <li>1) Attach the electric parts box and then connect with wires as original.</li> <li>2) Be sure to perform wiring in the electric parts box as original.</li> </ol> <p><b>Note</b></p> <hr/> <p>For the connectors, check there is no comingoff or connection error. By the code clamp and binding band beside an electric part box, as shown in the left figure, fix fan motor wiring.</p> <hr/> <ol style="list-style-type: none"> <li>3) Attach both air filter and center panel as original.</li> </ol>	

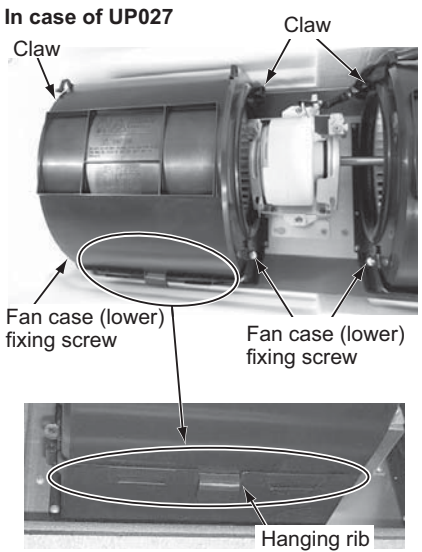
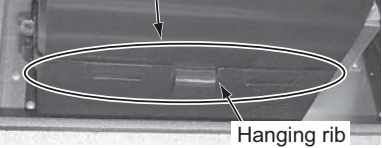
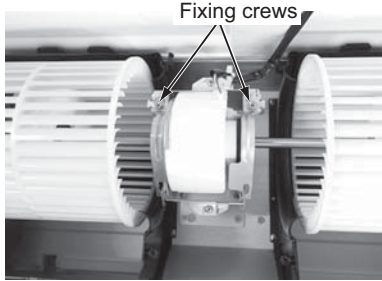
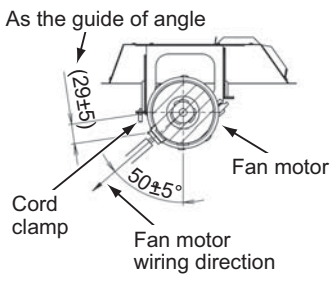
No.	Part name	Procedure	Remarks
④	Control P.C. board	<p><b>1. Detachment</b></p> <ol style="list-style-type: none"> <li>1) Perform work from 1) to 5) Detachment 1 of ③.</li> <li>2) Unlock the locks of the card edge spacers (at 4 positions) in the electric parts box and then remove the control P.C. board.</li> </ol> <p><b>2. Attachment</b></p> <ol style="list-style-type: none"> <li>1) Attach the control P.C. board in the electric parts box as original.</li> <li>2) Be sure to perform wiring in the electric parts box as original.</li> </ol> <p><b>Note</b></p> <hr/> <p>For the connectors, check there is no comingoff or connection error. By the code clamp and binding band beside an electric part box, as shown in the left figure, fix fan motor wiring.</p> <hr/> <ol style="list-style-type: none"> <li>3) Attach both air filter and center panel as original.</li> </ol>	<p>Cord clamp    Binding band</p>   <p>Card edge spacer</p>
⑤	Fan motor Turbo fan Bell mouth	<p><b>1. Detachment (In case of UP009)</b></p> <ol style="list-style-type: none"> <li>1) Perform work Detachment 1 of ③.</li> <li>2) Take off screws (M 4 × 8, 4 pcs.) and then remove the bell mouth.</li> <li>3) Take off screws (M 4 × 10, 2 pcs.) and then remove the nut cap.</li> <li>4) Take off nut and remove the turbo fan while supporting the turbo fan so that it does not fall.</li> <li>5) Take off screws (M 4 × 8, 2 pcs.) which fix the holding plate for wiring and then remove the holding plate for wiring.</li> <li>6) Remove the fan motor wire from the clamp.</li> <li>7) Take off nuts (3 positions) and then remove the fan motor.</li> </ol> <p><b>Note</b></p> <hr/> <p>Take off nuts while supporting the fan motor so that it does not fall.</p> <hr/> <p><b>2. Attachment (In case of UP009)</b></p> <ol style="list-style-type: none"> <li>1) Attach all the fan motor, turbo fan, nut cap, bell mouth and electric parts box as original. Be sure to perform wiring in the electric parts box as original.</li> </ol> <p><b>Note</b></p> <hr/> <p>Pass the fan motor wires necessarily through the clamp and the specified fixing slit for the fan motor wiring.</p> <hr/> <ol style="list-style-type: none"> <li>2) Check that the turbo fan does not hit the fan motor wiring by turning lightly the turbo fan with hands.</li> <li>3) Attach the air filter and the center panel as original.</li> </ol>	<p><b>In case of UP009</b></p>   

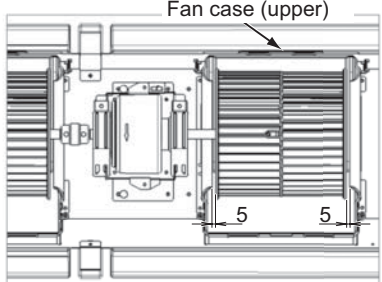
No.	Part name	Procedure	Remarks
⑥	Fan motor Fan Fan case	<p><b>1. Detachment (In cases of UP027)</b></p> <ol style="list-style-type: none"> <li>1) Perform work Detachment 1 of ②.</li> <li>2) In the works of 1 of ③, perform works to open the electric parts box cover and remove connectors of the fan motor wiring.</li> <li>3) Remove the fan case (lower) fixing screws. (at both sides of the case).</li> <li>4) Open the fan case (lower) while pushing claws (at both sides of the case) of the fan case (lower).</li> <li>5) Remove the hanging rib at opposite side of the claw and then open the fan case (lower).</li> <li>6) Take off screws of fixing sheet metal (2 pcs.) at side of the fan motor. (M 5 × 16, 2 pcs.)</li> </ol> <p><b>Note</b></p> <hr/> <p>Take off fixing screws while supporting the fan motor so that it does not fall.</p> <hr/> <ol style="list-style-type: none"> <li>7) Loose the hexagon socket screw to remove the fan from the shaft. (For 3mm, 1 pcs.)</li> </ol> <p><b>2. Attachment (In cases of UP027)</b></p> <ol style="list-style-type: none"> <li>1) Adjust the hexagon socket screw so that it fits groove of the shaft and then insert the fan into the shaft.</li> <li>2) Screw the fan motor with the fixing sheet metal. (M 5 × 16, 2 pcs.)</li> </ol> <p><b>Note</b></p> <hr/> <p>Match direction of the fan motor with turning direction of the fan and then fix the fan motor wiring so that it is set at piping side.</p> <p>* Ensure that the fan motor wiring directs at <math>50^{\circ} \pm 5^{\circ}</math> to the cord clamp side.</p> <hr/> <ol style="list-style-type: none"> <li>3) Using hexagon socket screw, fix the fan by positioning so that the fan is set at the center against the fan case (upper).</li> </ol> <p><b>Note</b></p> <hr/> <p>For fixing the fan, use torque wrench and tighten it with <math>4.9 \pm 0.49 \text{ N}\cdot\text{m}</math>.</p> <hr/> <ol style="list-style-type: none"> <li>4) Attach the fan case (lower) as original, and check the fan can turn smoothly without touching with the fan case.</li> <li>5) Connect the fan motor wires as original and then attach the electric parts box cover. Be sure to perform wiring in the electric parts box as original.</li> <li>6) Attach the air filter and the center panel as original.</li> </ol>	<p><b>In case of UP027</b></p>      

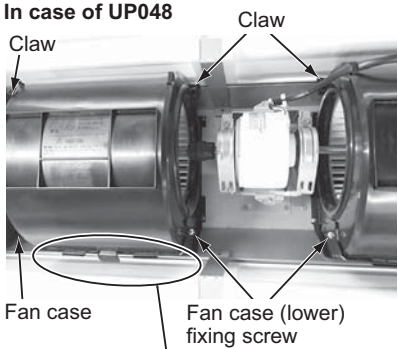
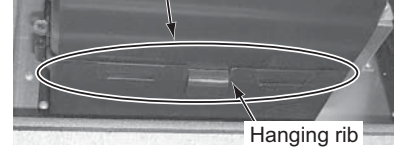
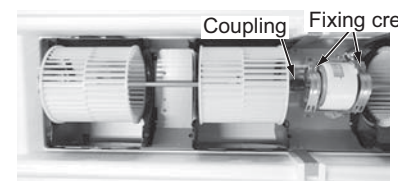
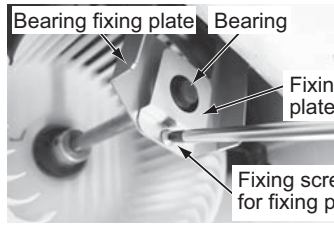
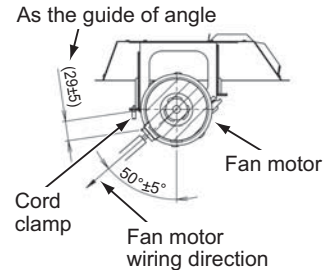
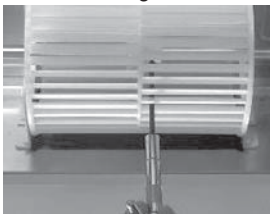
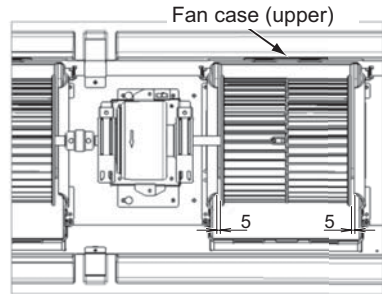

No.	Part name	Procedure	Remarks
⑥	Fan motor Fan Fan case Bearing	<p><b>1. Detachment (In cases of UP048)</b></p> <ol style="list-style-type: none"> <li>1) Perform work Detachment 1 of ②.</li> <li>2) In the works of 1 of ③, perform works to open the electric parts box cover and remove connectors of the fan motor wiring.</li> <li>3) Remove the fan case (lower) fixing screws. (at both sides of the case).</li> <li>4) Open the fan case (lower) while pushing claws (at both sides of the case) of the fan case (lower).</li> <li>5) Remove the hanging rib at opposite side of the claw and then open the fan case (lower). <ul style="list-style-type: none"> <li>• Connect the fan motor to the shaft with the coupling and fix them to the cabinet with the bearing. Remove it if necessary. Coupling: Hexagon socket screw (For 3mm, 2 pcs.)</li> </ul> </li> <li>6) Take off screws of fixing sheet metal (2 pcs.) at side of the fan motor. (M 5 × 16, 2 pcs.)</li> </ol> <p><b>Note</b></p> <hr/> <p>Take off fixing screws while supporting the fan motor so that it does not fall.</p> <hr/> <ol style="list-style-type: none"> <li>7) Loose the hexagon socket screw to remove the fan from the shaft. (For 3mm, 1 pcs.)</li> <li>8) Take off fixing screw for fixing plate to remove the bearing.</li> </ol> <p><b>2. Attachment (In cases of UP048)</b></p> <ol style="list-style-type: none"> <li>1) Insert the bearing securely to the bearing fixing plate and push them with the fixing plate to fix them with screw.</li> <li>2) Adjust the hexagon socket screw so that it fits groove of the shaft and then insert the fan into the shaft.</li> <li>3) Screw the fan motor with the fixing sheet metal. (M 5 × 16, 2 pcs.)</li> </ol> <p><b>Note</b></p> <hr/> <p>Match direction of the fan motor with turning direction of the fan and then fix the fan motor wiring so that it is set at piping side.</p> <p>* Ensure that the fan motor wiring directs at <math>50^{\circ} \pm 5^{\circ}</math> to the cord clamp side.</p> <hr/> <ol style="list-style-type: none"> <li>4) Using hexagon socket screw, fix the fan by positioning so that the fan is set at the center against the fan case (upper).</li> </ol> <p><b>Note</b></p> <hr/> <p>For fixing the fan, use torque wrench and tighten it with <math>4.9 \pm 0.49\text{N}\cdot\text{m}</math>.</p> <hr/> <ol style="list-style-type: none"> <li>5) Attach the fan case (lower) as original, and check the fan can turn smoothly without touching with the fan case.</li> <li>6) Connect the fan motor wires as original and then attach the electric parts box cover. Be sure to perform wiring in the electric parts box as original.</li> <li>7) Attach the air filter and the center panel as original.</li> </ol>	<p><b>In case of UP048</b></p>       

No.	Part name	Procedure	Remarks
⑦	Frame cover Adjust cover	<p><b>1. Detachment</b></p> <ol style="list-style-type: none"> <li>1) Perform work of Detachment 1 of ②.</li> <li>2) Take off screw (M 4 × 10, 1 pc.) and then remove the frame cover while pushing the claw to inner side.</li> <li>3) Take off screws which fix the adjust cover. (M 4 × 10, 2 pcs. : △ mark is sign.)</li> <li>4) Move the slide levers (2 positions) to inner side to move them to OPEN position (1). Move the slide levers while pushing them.</li> <li>5) Remove the adjust cover while sliding it to the arrow mark direction (2) by pushing it with hands so that it does not fall.</li> </ol> <p><b>2. Attachment</b></p> <ol style="list-style-type: none"> <li>1) Loosen the mounting screws (M 5 × 40, 2 pcs.) which fix the indoor unit and the ceiling panel and then lower the ceiling panel by approx. 10mm.</li> </ol> <p><b>Note</b></p> <hr/> <p>If you do not loosen the mounting screws, the adjust cover is not fixed.</p> <hr/> <ol style="list-style-type: none"> <li>2) Referring to the diagram “How to mount the adjust cover”, push the projected part of the adjust cover by thumb in the inner frame while widening it with hands (3). In this time, be sure to insert claws into the inner and outer frames.</li> <li>3) Pull (A) part to the arrow direction until one side each matches with the hole part (△ mark is sign.) and then move the slide lever to the LOCK position (4). Move the slide lever while pushing it.</li> <li>4) Using screws (M 4 × 10, 2 pcs.) taken off in 1. Detachment of ⑥, fix it.</li> </ol> <p><b>Note</b></p> <hr/> <p>When attaching the adjust cover, be sure to move it until there is no clearance at matching part with the outer frame.</p> <hr/> <ol style="list-style-type: none"> <li>5) Tighten screws (M 5 × 40, 2 pcs.) loosened in 1) Attachment of 2- ⑦ as original.</li> <li>6) Put in claw of the frame cover and then fix it with screw (M 4 × 10, 1 pc.)</li> </ol> <p><b>Note</b></p> <hr/> <p>Perform attachment as original. The incomplete attachment may cause dewing. In attachment work, be sure that the louver motor wires are not caught in.</p> <hr/> <ol style="list-style-type: none"> <li>7) Attach the air filter and the center panel as original.</li> </ol>	<p>The diagram illustrates the process of removing and reattaching the frame cover and adjust cover. It shows the frame cover being pushed inward to release the claw. The adjust cover is shown in its LOCK position (at shipment) and then being moved to OPEN positions. The attachment process involves loosening mounting screws, lowering the ceiling panel, and then pushing the adjust cover into the inner frame. The diagram also shows the adjust cover being fixed to the outer frame with screws and the frame cover being reattached with a screw.</p>

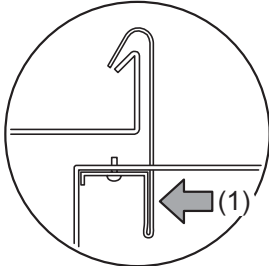
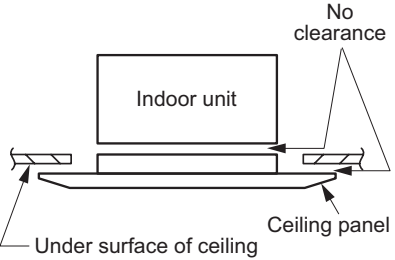
No.	Part name	Procedure	Remarks
⑧	Ceiling panel	<p><b>1. Detachment</b></p> <ol style="list-style-type: none"> <li>1) Perform work Detachment 1 of ②.</li> <li>2) In the works of 1 Detachment of ③, perform works to open the electric parts box cover and remove connector of the louver motor wiring.</li> <li>3) In the works of 1 Detachment of 6, perform work to remove the frame cover.</li> <li>4) Take off the mounting screws (M 5 × 40, 4 pcs. for UP009 and UP027, 6 pcs. for UP048) which fix the indoor unit and the ceiling panel.</li> <li>5) Lower the tentative hooks (Total 2 pcs. at left and right) slowly while pushing them with fingers (1). The position of tentative hook at the left side differs a little from hook at right side.</li> </ol> <p><b>2. Attachment</b></p> <ol style="list-style-type: none"> <li>1) Put the ceiling panel slantingly. Hang one side of the tentative hook to the indoor unit, lift up the other hook horizontally and hang it.</li> </ol> <p><b>Note</b></p> <hr/> <p>When hanging the ceiling panel, match the louver motor wiring side of the ceiling panel with the electric parts box side of the indoor unit.</p> <hr/> <ol style="list-style-type: none"> <li>2) Check that the tentative hooks at the both sides of the ceiling panel are surely hanged and then leave the hands. For the ceiling panel, tighten the mounting screws (M 5 × 40, 4 pcs. for UP009 and UP027, 6 pcs. for UP048) until it stick firmly to the indoor unit.</li> </ol> <p><b>Note</b></p> <hr/> <p>When tightening the mounting screws, check there is no catching of wire. Check there is no clearance between indoor unit and ceiling panel, and between ceiling panel and under face of the ceiling.</p> <hr/>	 <p>Tentative hook</p>   <p>No clearance</p> <p>Indoor unit</p> <p>Ceiling panel</p> <p>Under surface of ceiling</p>

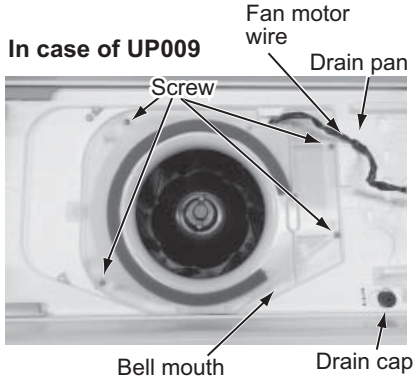
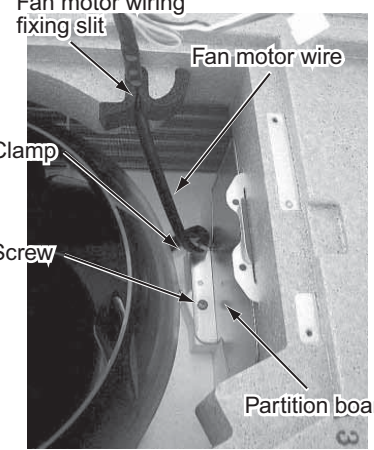
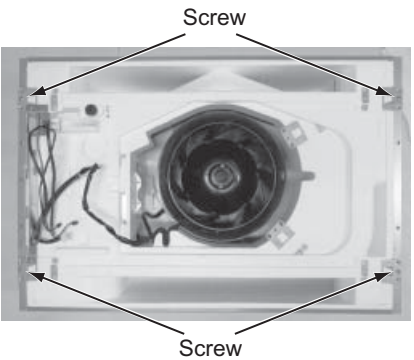
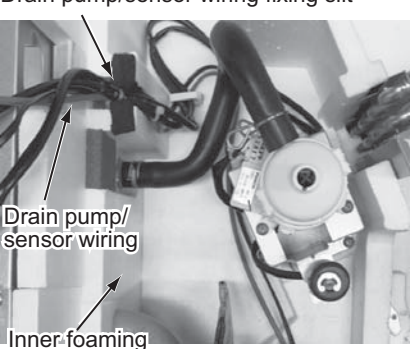
No.	Part name	Procedure	Remarks
⑨	Drain pan	<p><b>1. Detachment (In case of UP009)</b></p> <ol style="list-style-type: none"> <li>1) Perform work Detachment 1 of ③. Perform work Detachment 1 of ⑦.</li> <li>2) Take off the drain cap and then extract accumulated drain water in the drain pan.</li> </ol> <p><b>Note</b></p> <hr/> <p>When taking off the drain cap, be sure to receive drain water in a bucket, etc.</p> <hr/> <ol style="list-style-type: none"> <li>3) Remove the bell mouth followed to work of Detachment 1 of ⑤ and release fixing of the fan motor.</li> <li>4) Remove the fan motor wiring from clamp on the partition board.</li> <li>5) Take off screw (M 4 × 8, 1 pc.) which fixes the partition board and then remove it as if lifting up it.</li> <li>6) Take off screws at 4 corners (M 4 × 8, 4 pcs.) which fix the drain pan and then pull out the drain pan quietly.</li> </ol> <p><b>2. Attachment (In case of UP009)</b></p> <ol style="list-style-type: none"> <li>1) Attach the drain pan as original while passing the fan motor wiring and the drain pump/ sensor wiring through the specified hole.</li> </ol> <p><b>Note</b></p> <hr/> <p>Be sure to pass the drain pump sensor wiring through the specified fixing slit of the inner foaming. Be sure to pass also the fan motor wiring through the clamp and the fixing slit.</p> <hr/> <ol style="list-style-type: none"> <li>2) Attach all the partition board, bell mouth, electric parts box, ceiling panel, air filter and center panel as original. For wiring in the electric parts box, be sure to wire it as original.</li> </ol>	<p><b>In case of UP009</b></p>    

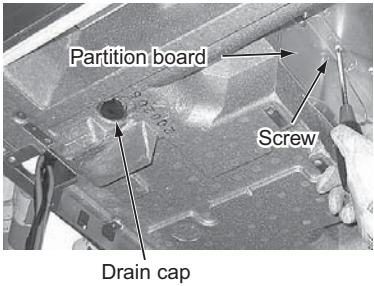
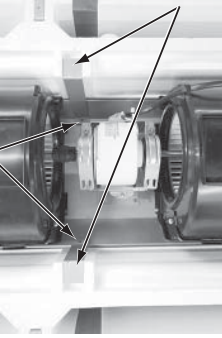
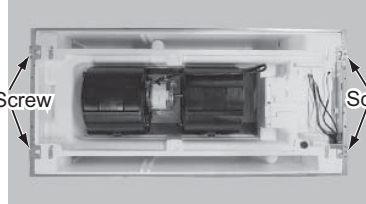
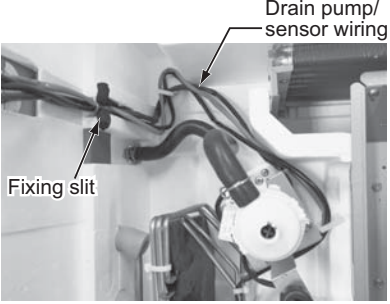
No.	Part name	Procedure	Remarks
⑨	Drain pan (Continued)	<p><b>1. Detachment (In cases of UP027/UP048)</b></p> <ol style="list-style-type: none"> <li>1) Perform work Detachment 1 of ③. Perform work Detachment 1 of ⑦.</li> <li>2) Take off the drain cap and then extract accumulated drain water in the drain pan.</li> </ol> <p><b>Note</b></p> <hr/> <p>When taking off the drain cap, be sure to receive drain water in a bucket, etc.</p> <hr/> <ol style="list-style-type: none"> <li>3) Take off screw (M 4 × 8, 1 pc.) which fixes the partition board and then remove it as if lifting up it. <ul style="list-style-type: none"> <li>• As shown in the right Photo, the drain pan is fixed by the drain pan fixing sheet metal at the both sides of the fan motor. Take off each screw and then remove the drain pan fixing board. (M 4 × 8, 1 pc. each)</li> </ul> </li> <li>4) Take off screws at 4 corners (M 4 × 8, 4 pcs.) which fix the drain pan and then pull out the drain pan quietly.</li> </ol> <p><b>2. Attachment (In cases of UP027/UP048)</b></p> <ol style="list-style-type: none"> <li>1) Attach the drain pan as original while passing the fan motor wiring and the drain pump sensor wiring through the specified hole.</li> </ol> <p><b>Note</b></p> <hr/> <p>Be sure to pass the drain pump sensor wiring through the specified fixing slit of the inner foaming.</p> <hr/> <ol style="list-style-type: none"> <li>2) Attach all the partition board, electric parts box, ceiling panel, air filter and center panel as original. For wiring in the electric parts box, be sure to wire it as original. <ul style="list-style-type: none"> <li>• Be sure necessarily to attach the drain pan fixing sheet metal for UP048 type.</li> </ul> </li> </ol>	<p><b>In cases of UP027/UP048</b></p>  <p><b>In case of UP048</b></p>   

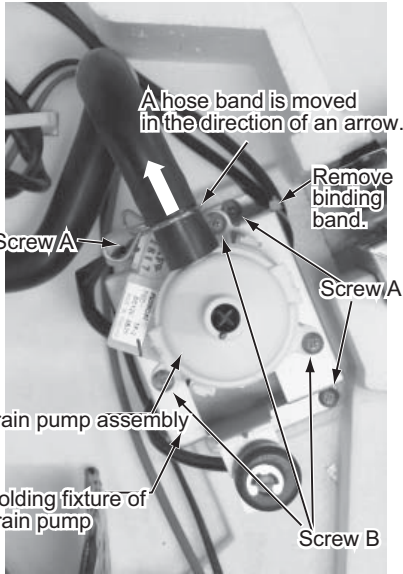
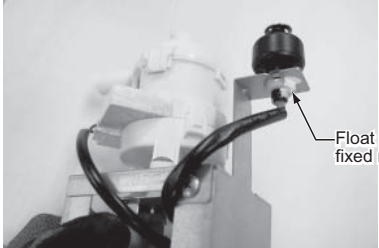

No.	Part name	Procedure	Remarks
⑩	Drain pump	<p><b>1. Detachment</b></p> <ol style="list-style-type: none"> <li>1) Perform work Detachment 1 of ⑨.</li> <li>2) Pick the hose band and shift it from the pump connecting part and then remove the drain hose.</li> <li>3) Take off screw A which fix the drain pump assembly and then remove the drain pump assembly. (M 4 × 8, 3 pcs.)</li> <li>4) Remove the binding band which is fixing the drain pump/float switch.</li> <li>5) Remove the screw B from holding fixture of drain pump, and remove a drain pump. (M 4 × 10, 3 pcs.)</li> </ol> <p><b>2. Attachment</b></p> <ol style="list-style-type: none"> <li>1) Using screws taken off from the drain pump assembly, fix the assembly as original.</li> <li>2) Fix the drain pump wiring to the slit for fixing the drain pump/sensor wiring.</li> <li>3) Connect the drain pump as original and then attach the hose band.</li> </ol> <p><b>Note</b></p> <hr/> <p>Insert the drain hose up to the back of the pump connecting part, and apply a band at the white mark of the hose.</p> <hr/> <ol style="list-style-type: none"> <li>4) Attach all the drain pan, partition board, electric parts box ceiling panel, air filter and center panel as original. For wiring in the electric parts box, be sure to wire it as original.</li> </ol>	 <p>A hose band is moved in the direction of an arrow.</p> <p>Screw A</p> <p>Remove binding band.</p> <p>Screw A</p> <p>Drain pump assembly</p> <p>Holding fixture of drain pump</p> <p>Screw B</p>
⑪	Float switch	<p><b>1. Detachment</b></p> <ol style="list-style-type: none"> <li>1) Perform work from 1) to 4) Detachment 1 of ⑩.</li> <li>2) Loosen the nut of a float switch and remove a float switch.</li> </ol> <p><b>2. Attachment</b></p> <ol style="list-style-type: none"> <li>1) Attach the float switch as original.</li> </ol>	 <p>Float switch fixed nut</p>

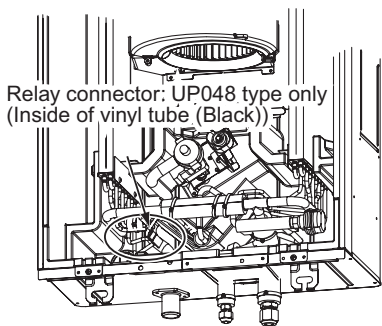
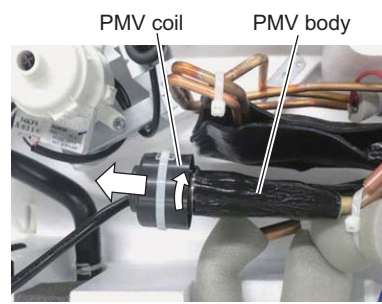
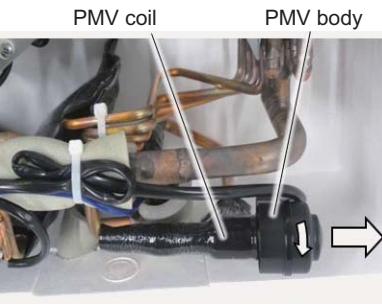
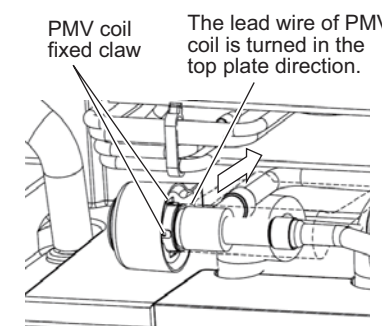
No.	Part name	Procedure	Remarks
⑫	PMV coil	<p><b>1. Detachment</b></p> <ol style="list-style-type: none"> <li>1) Perform work Detachment 1 of 8 .</li> <li>2) Remove the relay connector of PMV coil. (Only relay connector of UP048 type is connected in the vinyl tube. Therefore cut off the bundling band which fixes the tube and then remove the relay connector.)</li> <li>3) A little PMV coil is rotated, pressing down so that a PMV body may not turn, and it removes in the direction of an arrow.</li> </ol> <p><b>2. Attachment</b></p> <ol style="list-style-type: none"> <li>1) Attach PMV coil and relay connector as original.</li> </ol> <p><b>Note</b></p> <p>Be careful of direction of a PMV coil. Check that four projections of the fixed claw of PMV coil and PMV body have fitted in.</p>	 <p>Relay connector: UP048 type only (Inside of vinyl tube (Black))</p> <p><b>In cases of UP009/UP027</b></p>  <p>PMV coil      PMV body</p> <p><b>In cases of UP048</b></p>  <p>PMV coil      PMV body</p>  <p>PMV coil fixed claw      The lead wire of PMV coil is turned in the top plate direction.</p>

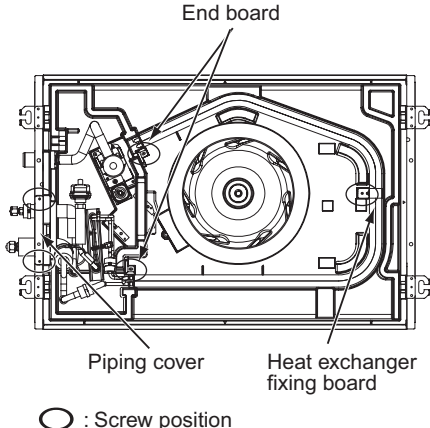
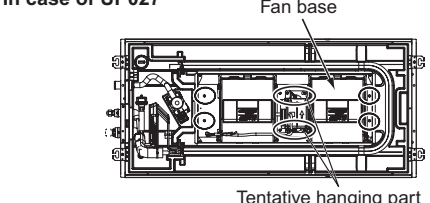
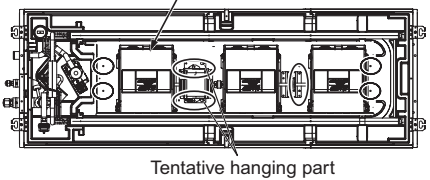
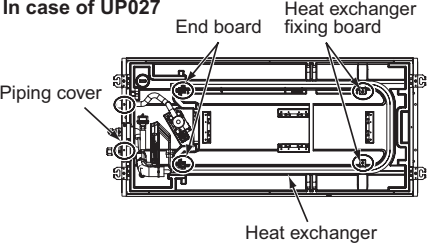
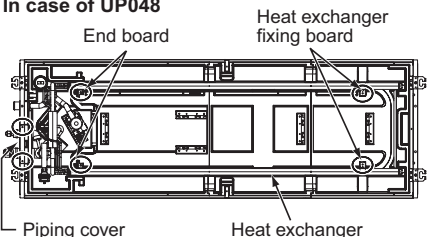
No.	Part name	Procedure	Remarks
⑬	Heat exchanger	<p><b>1. Detachment (In case of UP009)</b></p> <ol style="list-style-type: none"> <li>1) Recover the refrigerant gas and then remove the refrigerant pipe of the indoor unit.</li> <li>2) Perform work of Detachment 1 of ⑧.</li> <li>3) Pull out wires of TC1 sensor, TC2 sensor and TCJ sensor from the holder.</li> <li>4) Take off screws (M 4 × 8, 2 pcs.) and the piping cover.</li> <li>5) Take off screw (M 4 × 8, 1 pc.) and then remove the heat exchanger fixing board.</li> <li>6) While pressing the heat exchanger, take off screws fixing (M 4 × 8, 1 pc. each) of the end boards (2 pcs.), and then take out the heat exchanger slowly.</li> </ol> <p><b>2. Attachment (In case of UP009)</b></p> <ol style="list-style-type: none"> <li>1) Set the heat exchanger at the original position and then fix all the end board, heat exchanger fixing board and piping cover with taken-off screws as original.</li> <li>2) Insert wires for TC1 sensor, TC2 sensor and TCJ sensor into the holder and perform wiring as original.</li> <li>3) Attach all the drain pan, partition board, bell mouth, electric parts box, ceiling panel, air filter and center panel as original. Be sure to perform drawing of wires as same as original drawing.</li> </ol> <p><b>1. Detachment (In cases of UP027/UP048)</b></p> <ol style="list-style-type: none"> <li>1) Recover the refrigerant gas and then remove the refrigerant piping of the indoor unit.</li> <li>2) Perform work Detachment 1 of ⑧.</li> <li>3) Take off screws and remove the fan base. (For the tentative hanging parts at 2 positions, it is all right only to loosen screws.) UP027 type (Hexagon socket screw M 4 × 10, 10 pcs.) UP048 type (Hexagon socket screw M 4 × 10, 13 pcs.)</li> </ol> <p><b>Note</b></p> <hr/> <p>The fan or fan motor are attached to the fan base. If the base is heavy, remove each for working.</p> <hr/> <ol style="list-style-type: none"> <li>4) Pull out wires of TC1 sensor, TC2 sensor and TCJ sensor from the holder.</li> <li>5) Take off screws (M 4 × 10, 2 pcs.) and then remove the piping cover.</li> <li>6) Take off screw (M 4 × 10, 1 pc. each) and then remove the heat exchanger fixing boards (2 pcs.).</li> <li>7) While pressing the heat exchanger, take off screws fixing (M 4 × 10, 1 pc. each) of the end boards (2 pcs.), and then take out the heat exchanger slowly.</li> </ol> <p><b>2. Attachment (In case of UP027/UP048)</b></p> <ol style="list-style-type: none"> <li>1) Set the heat exchanger at the original position and then fix all the end board, heat exchanger fixing board and piping cover with taken-off screws as original.</li> <li>2) Insert wires for TC1 sensor, TC2 sensor and TCJ sensor into the holder and perform wiring as original.</li> <li>3) Attach all the drain pan, partition board, bell mouth, electric parts box, ceiling panel, air filter and center panel as original. Be sure to perform drawing of wires as same as original drawing.</li> </ol>	<p><b>In case of UP009</b></p>  <p>○ : Screw position</p> <p><b>In case of UP027</b></p>  <p>○ : Screw position</p> <p><b>In case of UP048</b></p>  <p><b>In case of UP027</b></p>  <p><b>In case of UP048</b></p> 



# 11-3. 1-way cassette (SH)

MMU-UP\*\*\*\*SH\*

## WARNING

Be sure to stop operation of the air conditioner before work and then turn off switch of the breaker.

## CAUTION

Be sure to put on gloves during working time; otherwise an injury will be caused by a part etc.

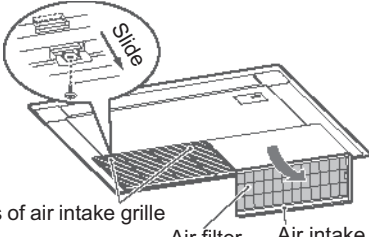
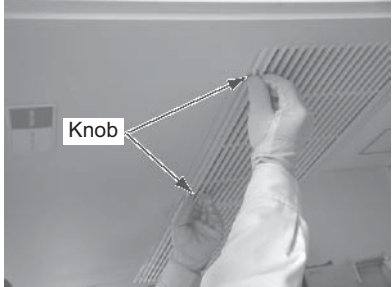
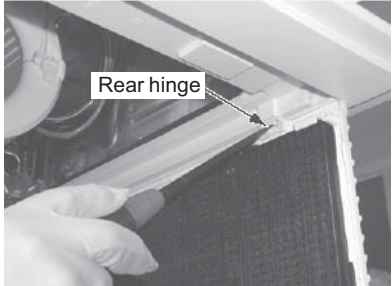
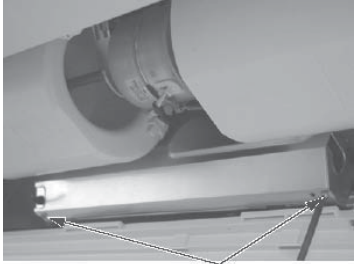
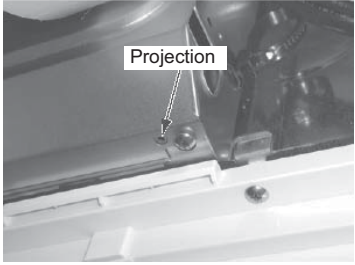

### Ceiling panel: RBC-US21PGE

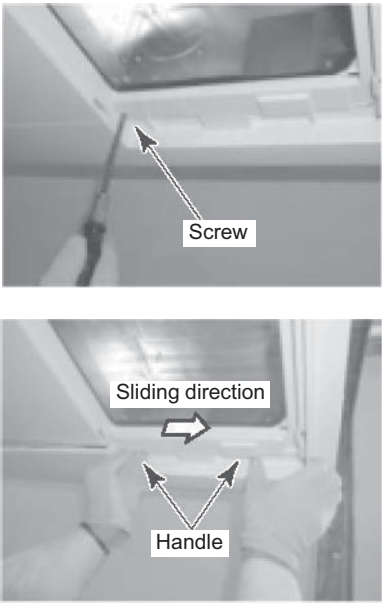
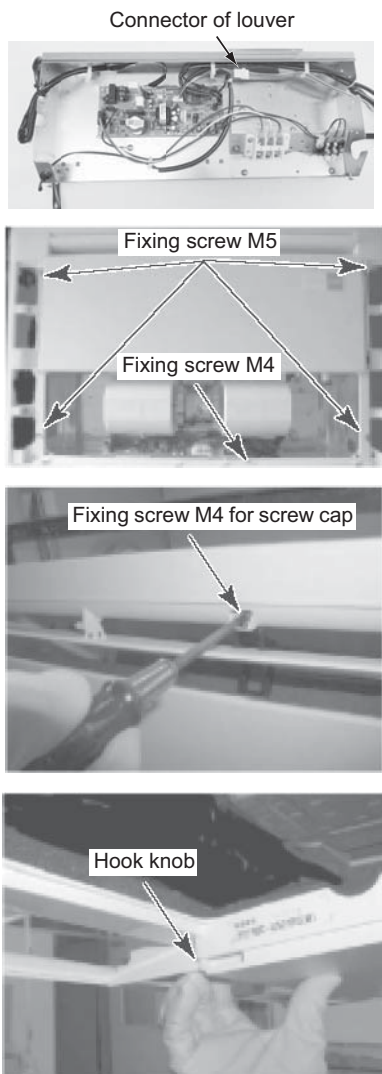
No.	Part name	Procedure	Remarks
①	Air intake grille	<p><b>1. Detachment</b></p> <ol style="list-style-type: none"> <li>1) Stop operation of the air conditioner, and then turn off switch of the breaker.</li> <li>2) Remove the screws of air intake grille fixing knob on a side of each filter.</li> </ol>  <ol style="list-style-type: none"> <li>3) Open the grilles by sliding knobs toward suction side. (Both 2 pieces at left and right sides)</li> <li>4) Pull out the grille by pushing claws at rear hinge (2 positions) with (-) screwdriver.</li> </ol> <p><b>2. Attachment</b></p> <ol style="list-style-type: none"> <li>1) Insert the rear hinge (2 positions) into square holes of the panel. (Insert it surely up to the end.)</li> </ol> <p><b>NOTE</b></p> <p>After inserting the hinge, check the grille does not fall out even if pulling the grilles.</p> <ol style="list-style-type: none"> <li>2) Close the grilles and slide the hooks (2 positions) toward discharge side to fix them.</li> <li>3) Tighten the screws of air intake grille fixing knob on a side of each filter.</li> </ol>	 <p>Knob</p>  <p>Rear hinge</p>
②	Electric parts cover	<p><b>1. Detachment</b></p> <ol style="list-style-type: none"> <li>1) Perform work of procedure 1. of ①.</li> <li>2) Loosen fixing screws. (M 4 ×8, 2 pcs)</li> <li>3) Pull down the cover and shift it to the fan motor side to remove it.</li> </ol> <p><b>2. Attachment</b></p> <ol style="list-style-type: none"> <li>1) Insert the cover along edge of the electrical control box and match the projection inside of the fixing screw with hole of the cover.</li> <li>2) Tighten the fixing screws. (M 4 × 8, 2 pcs)</li> </ol>	 <p>Screws (2 positions)</p>  <p>Projection</p>

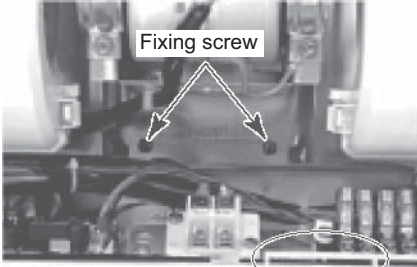
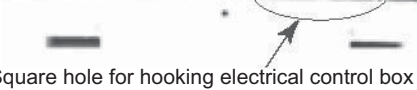
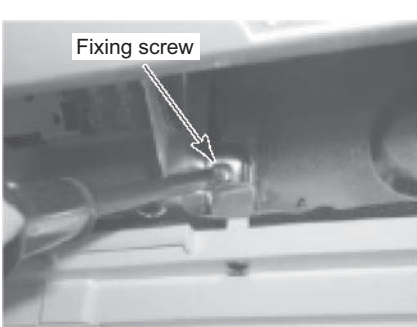
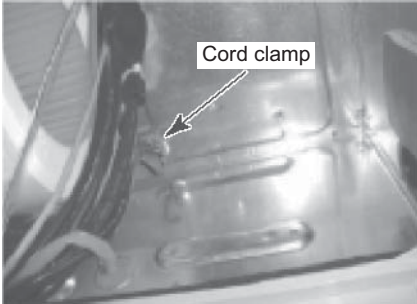
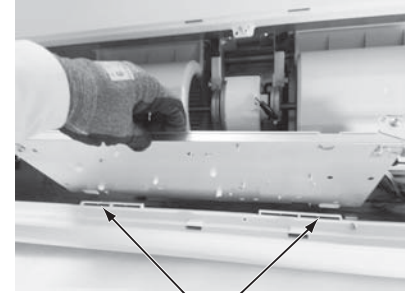

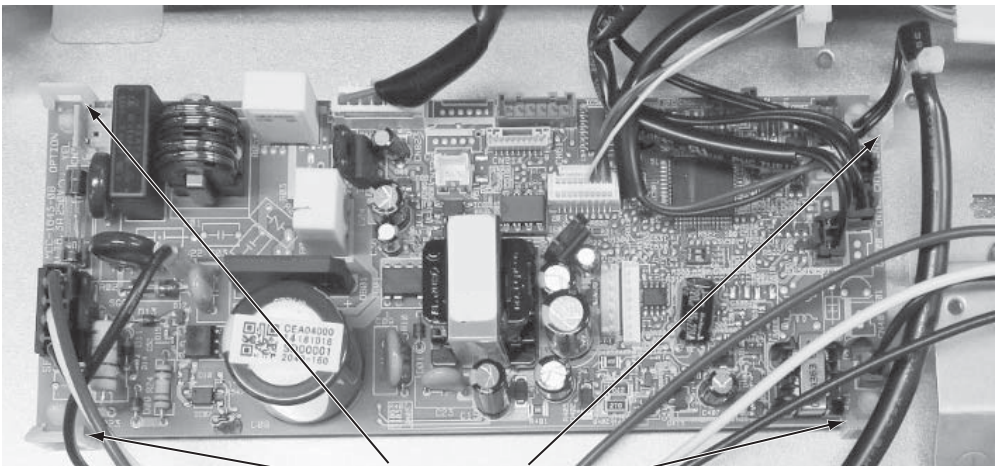
No.	Part name	Procedure	Remarks
③	Adjust cap	<p><b>1. Detachment</b></p> <ol style="list-style-type: none"> <li>1) Perform work of procedure 1. of ①.</li> <li>2) Take off fixing screws. (M4 × 12, 2 pcs)</li> <li>3) Hold handle of the cap, and then slide it toward suction side to remove cap.</li> </ol> <p><b>2. Attachment</b></p> <ol style="list-style-type: none"> <li>1) Catch on the top claw and slide it toward discharge side for attachment.</li> <li>2) Fit the fixing screws. (M4 × 12, 2 pcs)</li> </ol>	
④	Ceiling panel	<p><b>1. Detachment</b></p> <ol style="list-style-type: none"> <li>1) Perform works of procedures 1. of ② and 1. of ③.</li> <li>2) Remove a louver connector from the relay connector (5P: white ) of the control P.C. board, and remove the lead wires of ceiling panel.</li> </ol> <p><b>NOTE</b></p> <hr/> <p>When removing the connector, unlock the lock of the housing.</p> <hr/> <ol style="list-style-type: none"> <li>3) Take off screws fixing the ceiling panel. (M 5 × 4 pcs, M 4 × 2 pcs)</li> </ol> <p><b>NOTE</b></p> <hr/> <p>Be sure to open the screw cap before taking off the fixing screw (M4) at the center of the discharge port.</p> <hr/> <ol style="list-style-type: none"> <li>4) While pulling down the ceiling panel by pushing the knob of hook (movable) at right side of the panel toward inner side, remove the hook (movable) and also the hook (movable) at left side to pull down the ceiling panel by lifting the left side of the panel and sliding toward outside.</li> </ol> <p><b>2. Attachment</b></p> <ol style="list-style-type: none"> <li>1) Hook the hooks at both sides of the ceiling panel to the indoor unit.</li> <li>2) Fit the fixing screws. (M5 × 4 pcs, M 4 × 2 pcs)</li> </ol> <p><b>NOTE</b></p> <hr/> <p>Be sure to close the screw cap after screwing the fixing screw (M 4) at the center of the discharge port.</p> <hr/> <ol style="list-style-type: none"> <li>3) Connect a louver connector from the relay connector (5P: white) of a control P.C. board, and fix the lead wire of ceiling panel to a clamp.</li> </ol>	

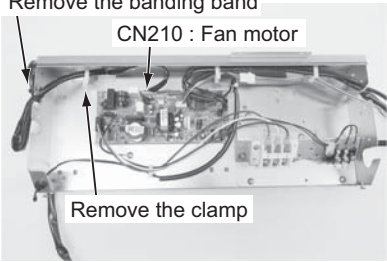
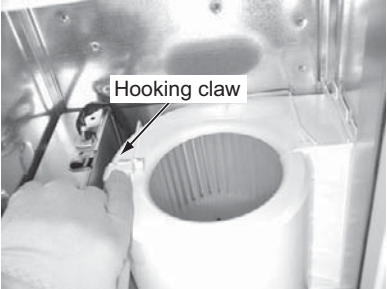
No.	Part name	Procedure	Remarks
⑤	Electrical control box	<p><b>1. Detachment</b></p> <ol style="list-style-type: none"> <li>1) Perform work of procedure 1. of ②.</li> <li>2) Take off the fixing screws. (M 4 × 8, 4 pcs)</li> <li>3) Remove the cord clamp on the ceiling surface, pull the electrical control box downward, and then hook the hooking claw at the rear side to square hole for temporary hanging of the panel.</li> </ol> <p><b>2. Attachment</b></p> <ol style="list-style-type: none"> <li>1) Take off the hook at the rear side of the electrical control box.</li> <li>2) Return the electrical control box at the original position, and then fit the fixing screws. (M 4 × 8, 4 pcs)</li> <li>3) Using cord clamp at the ceiling surface, fix the lead wires as before.</li> </ol>	 <p>Fixing screw</p>  <p>Square hole for hooking electrical control box</p>  <p>Fixing screw</p>  <p>Cord clamp</p>  <p>Square hole for temporary hanging</p>

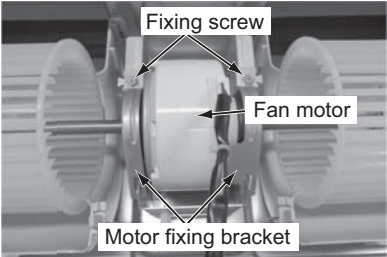
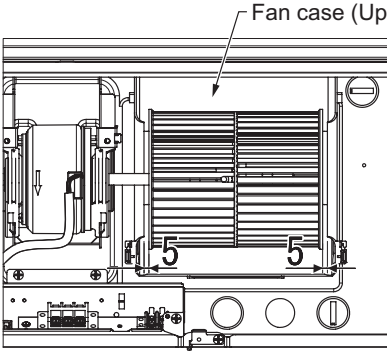

No.	Part name	Procedure	Remarks
⑥	Control P.C. board	<p><b>1. Detachment</b></p> <ol style="list-style-type: none"> <li>1) Perform work of procedure 1. of ⑤.</li> <li>2) Remove connectors connected from the control P.C. board to other parts.</li> </ol> <p><b>NOTE</b></p> <hr/> <p>Be sure to unlock the lock of the housing before removing the connector.</p> <hr/> <p>CN510 : Louver motor (20P: White)  CN34 : Float switch (3P: Red)  CN41 : Remote controller terminal block (3P: Blue)  (Screws of terminal block: 4P)  CN67 : Power supply terminal block (2P: Black)  (Screws of terminal block: 2P)  CN504 : Drain pump (2P: White)  CN82 : PMV (6P: Blue)  CN100 : TC1 sensor (3P: Brown)  CN101 : TC2 sensor (2P: Black)  CN102 : TCJ sensor (2P: Red)  CN104 : Room temp. Sensor (2P: Yellow)  CN210 : Fan motor (5P: White)</p> <ol style="list-style-type: none"> <li>3) Unlock the locks of the card edge spacers (4 positions), and then remove the control P.C. board.</li> </ol> <p><b>2. Attachment</b></p> <ol style="list-style-type: none"> <li>1) Fix the control P.C. board to the card edge spacers (4 positions).</li> <li>2) Connect the connectors disconnected in item 1 as before.</li> </ol> <p><b>NOTE</b></p> <hr/> <p>Check connectors have no missing or contact failure.</p> <hr/>	
		 <p style="text-align: center;">Card edge spacer</p>	

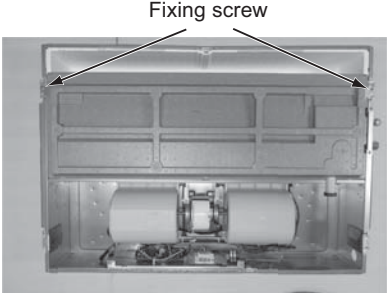
No.	Part name	Procedure	Remarks
⑦	Fan motor fan	<p><b>1. Detachment</b></p> <ol style="list-style-type: none"> <li>1) Perform work of procedure 1. of ⑤.</li> <li>2) Remove the banding band and clamps of the lead wires which are connected to the following connectors of the control P.C. board.</li> </ol> <p><b>NOTE</b></p> <p>Be sure to unlock the lock of the housing before removing the connector.</p> <p>CN210: Fan motor (7P: White)</p> <ol style="list-style-type: none"> <li>3) Remove the hooking claws at both sides of the fan case (lower) and remove the fan by pulling out it from the partition board.</li> <li>4) Loosen hexagon socket head screw of the fan.</li> <li>5) Remove screws of the fixing bracket while holding the fan motor, and then remove the fan and the fan motor.</li> </ol> <p><b>2. Attachment</b></p> <ol style="list-style-type: none"> <li>1) Insert the fan into the shaft of the motor and screw the fan motor with the fixing bracket. For the boss of the fan, attach hexagon socket head screw to shaft of the motor matching the marked position of the shaft with groove of the fan.</li> </ol> <p><b>NOTE</b></p> <p>Match the rotation direction of the motor with that of the fan, and fix the fan motor so that the motor lead section comes to the piping side referring to the right photo.</p> <ol style="list-style-type: none"> <li>2) Determine the position so that the fan locates at the center against the fan case (upper), and then fix the fan with hexagon socket head screw.</li> </ol> <p><b>NOTE</b></p> <p>Use a torque wrench and tighten the screw with 4.9 N•m or more to fix the fan.</p> <ol style="list-style-type: none"> <li>3) Mount the fan case (lower) as before, and check the fan smoothly rotates without contacting with fan case.</li> <li>4) Connect the connectors disconnected in procedure ①.</li> <li>5) Fix parts as before in order of Electric parts box → Electric parts cover → Air intake grille.</li> </ol>	<p>Remove the banding band</p>  <p>Hooking claw</p>  <p>Relief groove</p>  <p>Fixing screw</p> <p>Fan motor</p> <p>Motor fixing bracket</p>  <p>Fan case (Upper)</p> 

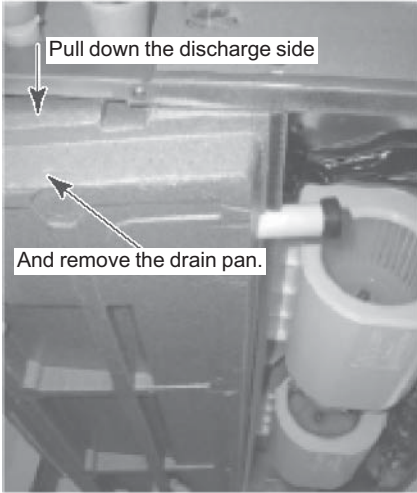

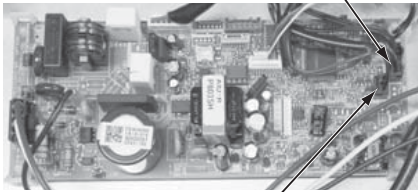
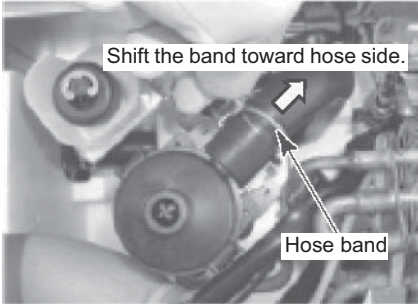
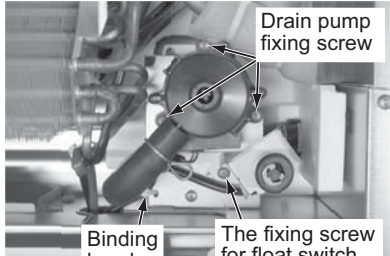
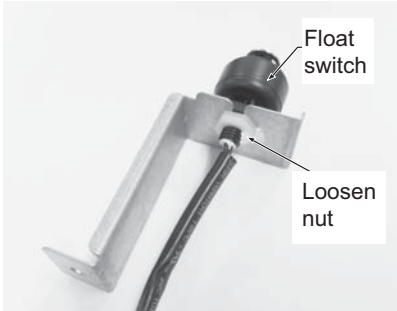
No.	Part name	Procedure	Remarks
⑧	Drain pan	<p><b>1. Detachment</b></p> <ol style="list-style-type: none"> <li>1) Perform work of procedure 1. of ④.</li> <li>2) Remove the drain cap, and then drain the drain water accumulated in the drain pan.</li> </ol> <p><b>NOTE</b></p> <hr/> <p>When removing the drain cap, be sure to catch drain water using bucket, etc.</p> <hr/> <ol style="list-style-type: none"> <li>3) Take off screws fixing the drain pan. (M 4 × 8, 2 pcs)</li> <li>4) Remove the drain pan while lowering the discharge side.</li> </ol> <p><b>2. Attachment</b></p> <ol style="list-style-type: none"> <li>1) Fix parts as before in order of Drain cap → Drain pan → Ceiling panel → Electric parts cover → Adjust cover → Air intake grille.</li> </ol>	  

No.	Part name	Procedure	Remarks
⑨	Drain pump	<p><b>1. Detachment</b></p> <ol style="list-style-type: none"> <li>1) Perform work of procedure 1. of ⑧.</li> <li>2) Remove clamps of the lead wires connected to the following connectors of the control P.C. board.</li> </ol> <p><b>NOTE</b></p> <hr/> <p>Be sure to unlock the lock of the housing before removing the connector.</p> <hr/> <p>CN504 : Drain pump (2P: White)</p> <ol style="list-style-type: none"> <li>3) Pick the hose band and shift band from pump connecting part to remove the drain hose.</li> <li>4) Take off screws fixing the drain pump assembly. (M 4 × 8, 3 pcs)</li> <li>5) Pull out the drain pump assembly toward discharge side to remove it.</li> </ol> <p><b>2. Attachment</b></p> <ol style="list-style-type: none"> <li>1) Fix the drain pump assembly as before.</li> <li>2) Connect the drain hose and attach the hose band.</li> </ol> <p><b>NOTE</b></p> <hr/> <p>Insert the drain hose completely up to the end of the pump connecting part, and then attach band at the white mark position of the hose.</p> <hr/> <ol style="list-style-type: none"> <li>3) Insert the connectors to the control P.C. board as before.</li> <li>4) Fix parts as before in order of Drain cap → Drain pan → Ceiling panel → Electric parts cover → Adjust cover → Air intake grille.</li> </ol>	<p>CN504 : Drain pump</p>  <p>CN34 : Float switch</p>  <p>Shift the band toward hose side.</p> <p>Hose band</p>  <p>Drain pump fixing screw</p> <p>Binding band</p> <p>The fixing screw for float switch fixtures</p>
⑩	Float switch	<p><b>1. Detachment</b></p> <ol style="list-style-type: none"> <li>1) Perform work of procedure 1. of ⑧.</li> <li>2) Remove clamps of the lead wires connected to the following connectors on the control P.C. board.</li> </ol> <p><b>NOTE</b></p> <hr/> <p>Be sure to unlock the lock of the housing before removing the connector.</p> <hr/> <p>CN 34 : Float switch (3P: Red)</p> <ol style="list-style-type: none"> <li>3) Remove the float switch fixture. (M 4 × 10, 1 pcs)</li> <li>4) Remove the binding band fixing wires</li> <li>5) Loosen the nut fixing float switch to remove the float switch.</li> </ol>	 <p>Float switch</p> <p>Loosen nut</p>

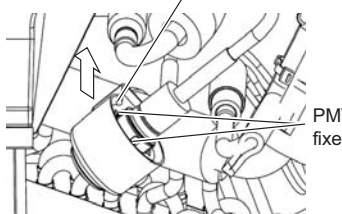
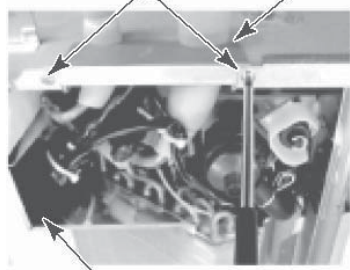
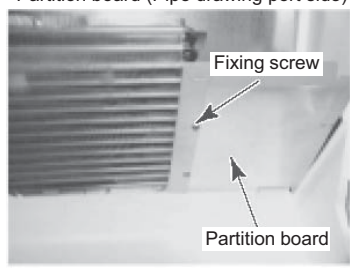
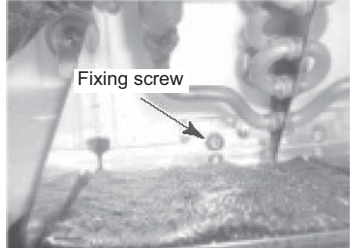
No.	Part name	Procedure	Remarks
⑪	PMV coil	<p><b>1. Detachment</b></p> <ol style="list-style-type: none"> <li>1) Perform work of procedure 1. of ⑧.</li> <li>2) Remove the relay connector of PMV coil. (As the relay connectors are connected in the vinyl tube, cut off the banding band fixing the both ends of the tube and shift the tube to remove relay connector.)</li> <li>3) A little PMV coil is rotated, pressing down so that a PMV body may not turn, and it removes in the direction of an arrow.</li> </ol> <p><b>2. Attachment</b></p> <ol style="list-style-type: none"> <li>1) Mount PMV coil and the relay connector as before.</li> </ol> <p><b>NOTE</b></p> <hr/> <p>Be careful of direction of a PMV coil. Check that four projections of the fixed claw of PMV coil and PMV body have fitted in.</p> <hr/>	<p>Relay connector (In vinyl tube (Black))      Banding band</p>  <p>PMV motor</p> <p>PMV body      PMV coil</p>  <p>The lead wire of PMV coil is turned in the top plate direction.</p>  <p>PMV coil fixed claw</p>
⑫	Heat exchanger	<p><b>1. Detachment</b></p> <ol style="list-style-type: none"> <li>1) Recover the refrigerant gas.</li> <li>2) Remove the refrigerant pipe of the indoor unit.</li> <li>3) Perform work of procedure 1. of ⑧.</li> <li>4) Remove the pipe cover by taking off fixing screws of the cover. (M 4 × 8, 2 pcs)</li> <li>5) Remove the clamp which fixes TC1 sensor, TC2 sensor and TCJ sensor, and then pull out the sensors from the holder.</li> <li>6) Remove the heat exchanger by taking off fixing screws of the partition board while holding the heat exchanger. (M 4 × 8, 4 pcs)</li> </ol> <p><b>2. Attachment</b></p> <ol style="list-style-type: none"> <li>1) Fix parts as before in order of Heat exchanger → Sensors → Pipe cover → Drain cap → Drain pan → Ceiling panel → Electric parts cover → Adjust cover → Air intake grille.</li> <li>2) Connect the refrigerant pipe as before, and then perform vacuuming.</li> </ol>	<p>Fixing screw      Pipe cover</p>  <p>Partition board (Pipe drawing port side)</p>  <p>Fixing screw</p>  <p>Partition board</p> <p>Fixing screw</p>



# 11-4. Floor standing cabinet

MML-UP\*\*\*\*H\*

## WARNING

Be sure to stop operation of the air conditioner before work and then turn off switch of the breaker.

## CAUTION

Be sure to put on gloves during working time; otherwise an injury will be caused by a part etc.

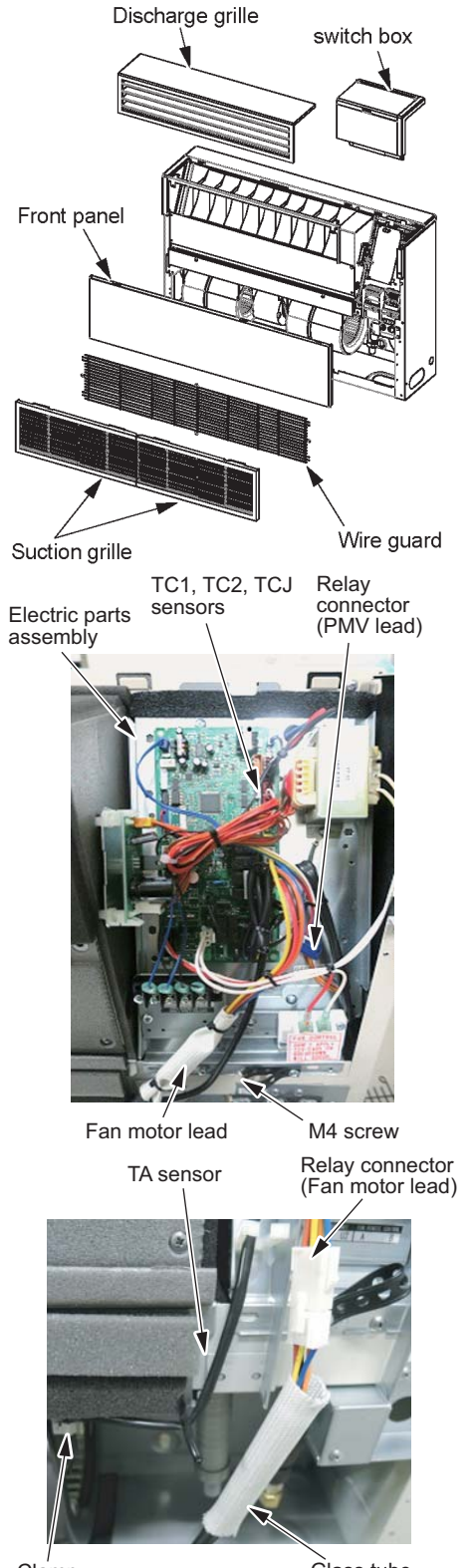
No.	Spare parts	Work procedure	Remarks
①	Electric parts assembly	<p><b>1. Detachment</b></p> <ol style="list-style-type: none"> <li>(1) Remove the suction grilles (2 pieces). (No screw fixing)</li> <li>(2) Remove the wire guard. (M4 screw: 4 pieces)</li> <li>(3) Remove the front panel. (M4 screw: 2 pieces)</li> <li>(4) Remove the discharge grille. (M4 x 20L : 2 pieces)</li> <li>(5) Remove the switch box. (M4 screw: 3 pieces)</li> <li>(6) Remove the fan motor lead from the clamp, slide the glass tube, and then remove the relay connector.</li> <li>(7) Remove the TA sensor from the clamp.</li> <li>(8) Remove the connectors of TC1, TC2, and TCJ sensors from P.C. board. CN100...TC1 (3P: Brown) CN101...TC2 (2P: Black) CN102...TCJ (2P: Red) * Unlock the lock of the housing part, and then remove the connectors.</li> <li>(9) Remove the relay connector of the PMV lead.</li> <li>(10) Remove body of the electric parts assembly. (M4 screw: 1)</li> </ol> <p><b>2. Attachment</b></p> <p>Following step 1 of ① and (1) to (10), attach the parts as original in the reverse procedure.</p>	 <p>The diagram shows the front panel assembly in an exploded view. At the top, there are two discharge grilles and a switch box. Below them is the front panel, which is held in place by a wire guard. The wire guard is secured with M4 screws. Below the front panel are two suction grilles. The TC1, TC2, and TCJ sensors are shown connected to the relay connector. The fan motor lead is shown connected to the relay connector. The TA sensor is shown connected to the relay connector. The electric parts assembly is shown at the bottom, with the fan motor lead, M4 screw, TA sensor, and relay connector (Fan motor lead) labeled. The clamp and glass tube are also shown at the bottom.</p>

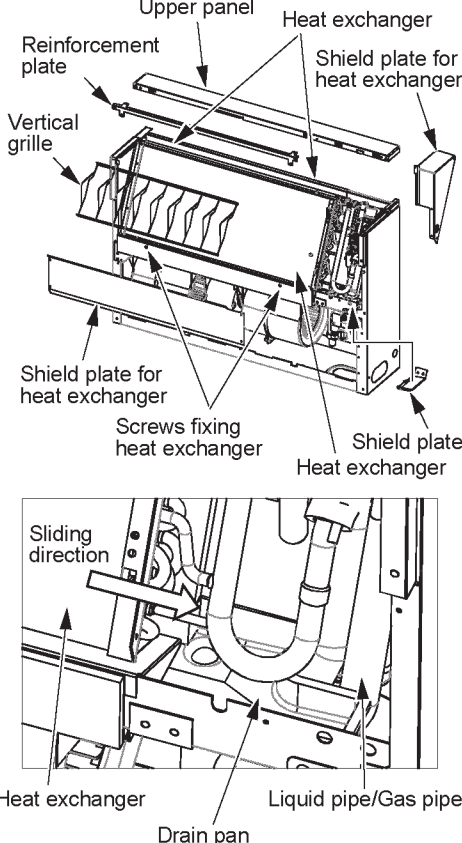
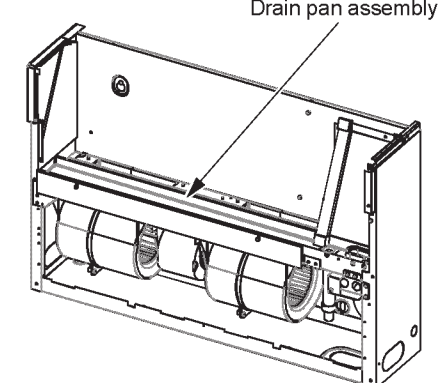
No.	Spare parts	Work procedure	Remarks
②	Refrigerant cycle assembly	<p><b>1. Detachment</b></p> <p>(1) Recover the refrigerant gas.</p> <p>(2) Take off the connecting pipe. (Liquid pipe and gas pipe)</p> <p>(3) Following to works 1 of ① , and (1) to (10), detach the parts.</p> <p>(4) Take off the reinforcement plate. (M4 screw: 2 pieces)</p> <p>(5) Remove the upper panel. (M4 screws: 4 pieces)</p> <p>(6) Remove the vertical grille. (M4 screws: 4 pieces)</p> <p>(7) Remove the shield plate for heat exchanger (Front). (M4 screws: 3 pieces)</p> <p>(8) Remove the shield plate for heat exchanger (Right). (M4 screws: 2 pieces)</p> <p>(9) Take off the screws which fix the heat exchanger. (M4 screws: 4 pieces)</p> <p>(10) Remove the shield plate. (M4 screws: 2 pieces)</p> <p>(11) Slide the heat exchanger horizontally, release liquid pipe, gas pipe from the drain pan, and then pull out it to the upper side.</p> <p><b>2. Attachment</b></p> <p>Following step 1 of ② and those in (1) to (11), attach the parts as original in the reverse procedure.</p>	
③	Drain pan assembly	<p><b>1. Detachment</b></p> <p>(1) Following step 1 of ② and those in (1) to (11), detach the parts.</p> <p>(2) Remove the drain pan assembly.</p> <p><b>2. Attachment</b></p> <p>Following step 1 in ③ and those in (1) to (2), attach the parts as original in the reverse procedure.</p>	

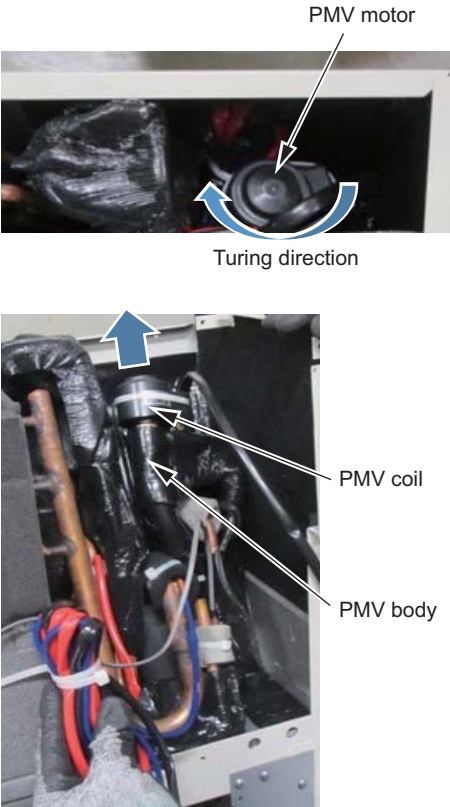
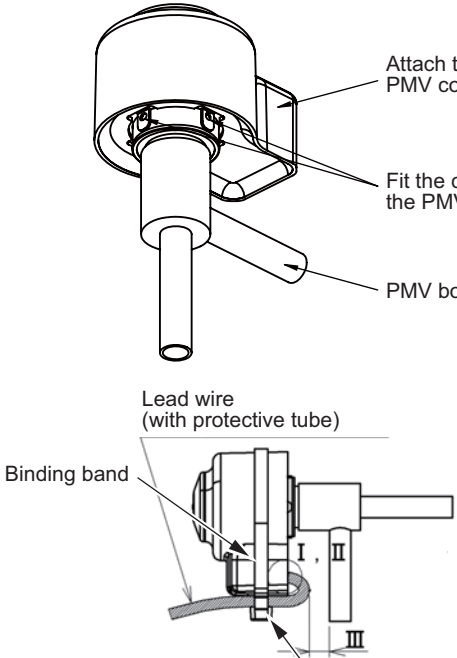
No.	Spare parts	Work procedure	Remarks
④	Horizontal louver	<p><b>1. Detachment</b></p> <p>(1) Following step 1 of ② and those in (3) to (5), detach the parts.</p> <p>(2) Remove the PMV connector : CN082 (6P Blue) from the P.C.board.</p> <p>(3) Turn the PMV coil slightly clockwise while holding the PMV body so that the body does not turn, and remove the PMV coil in the arrow direction.</p> <p><b>2. Attachment</b></p> <p>(1) Attach the PMV coil as before and check it does not move.</p> <p><b>NOTE</b></p> <p>Check the direction of the PMV coil.  Check the claw holes in the PMV coil are securely placed into four claws on the PMV body.  Check the position of the lock part on the binding band fixing the lead wires.</p> <hr/> <p>(2) Attach the PMV connector : CN082 (6P Blue)</p> <p>(3) Following step 1 of ④ and (1), attach the parts as original in the reverse procedure.</p>	 <p>PMV motor</p> <p>Turning direction</p> <p>PMV coil</p> <p>PMV body</p>
		 <p>Attach the PMV coil to the PMV body so that the PMV coil protrusion part points to the PMV body inlet.</p> <p>Fit the claw holes on the PMV coil into four claws on the PMV body.</p> <p>PMV body inlet</p> <p>Lead wire (with protective tube)</p> <p>Binding band</p> <p>I, II, III</p> <p>Ensure that the lock part on the binding band comes to the position in the figure.</p> <p>Caution when fixing the lead wire with the binding band.</p> <p>I . Do not apply tension to the drawing part on the coil lead wire.</p> <p>II . Insert the protective tube up to the root of drawing part on the lead wire.</p> <p>III . Ensure that the PMV pipe does not come to contact with the protective tube.</p>	

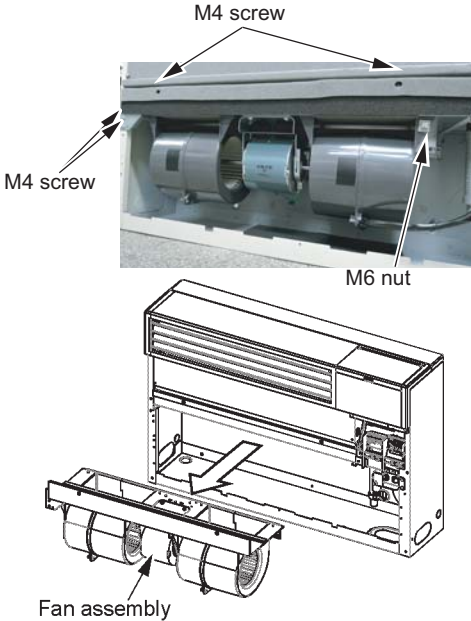
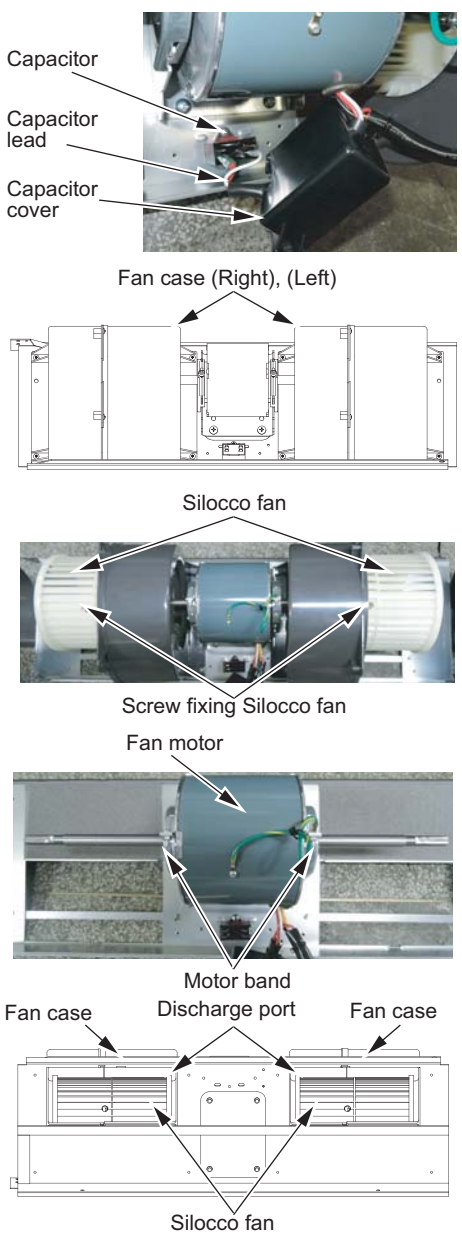
No.	Spare parts	Work procedure	Remarks
⑤	Fan assembly	<p><b>1. Detachment</b></p> <p>(1) Following step 1 of ① , (1) to (3), (6 )and (7), detach the parts.</p> <p>(2) Take off the nut which fixes the fan assembly. (M6 nut: 1 position)</p> <p>(3) Draw out the fan assembly toward you. (M4 screws: 4 pieces)</p> <p><b>2. Attachment</b></p> <p>Following step 1 of ④ , and (1) to (3), attach the parts as original in the reverse procedure.</p>	 <p>M4 screw</p> <p>M4 screw</p> <p>M6 nut</p> <p>Fan assembly</p>
⑥	Fan motor	<p><b>1. Detachment</b></p> <p>(1) Following step 1 of ④ and (1) to (3), detach the parts.</p> <p>(2) Take off the capacitor lead from the capacitor. (M4 screws: 2 pieces)</p> <p>(3) Take off the screws at (right) and (left) of the fan case. (M4 screws: 8 pieces, M4 x 12L : 4 pieces)</p> <p>(4) Remove the fan case at the outside.</p> <p>(5) Loosen screws of the Silocco fan to remove the Silocco fan.</p> <p>(6) Loosen the fixing screws of the fan motor, and then remove the fan motor. (M4 x 12L : 2 pieces)</p> <p><b>2. Attachment</b></p> <p>Following step 1 of ⑤ and (1) to (5), attach the parts as original in the reverse procedure.</p> <p>* When attaching the Silocco fan, meet the fixing screw for Silocco fan to the notch position on the shaft of the fan motor.</p> <p>* After fixing the fan case, adjust the position of Silocco fan at the center of the fan case from side of the discharge port so that the Silocco fan does not hit the fan case.</p> <p>* For the tightening torque of the screw fixing the Silocco fan, control between 5.0 to 5.2 N•m.</p>	 <p>Capacitor</p> <p>Capacitor lead</p> <p>Capacitor cover</p> <p>Fan case (Right), (Left)</p> <p>Silocco fan</p> <p>Screw fixing Silocco fan</p> <p>Fan motor</p> <p>Motor band</p> <p>Discharge port</p> <p>Fan case</p> <p>Fan case</p> <p>Silocco fan</p> <p>Screw fixing Silocco fan</p> <p>Shaft</p> <p>Silocco fan</p>

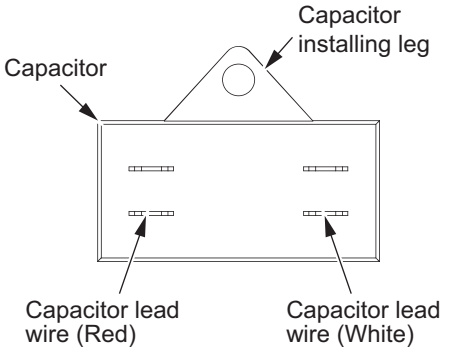
No.	Spare parts	Work procedure	Remarks
⑦	Capacitor	<p><b>1. Detachment</b>            (1) Following step 1 of ⑤ and (1) to (2), detach the parts.            (2) Remove the capacitor.            (M4 screw: 1 position)</p> <p><b>2. Attachment</b>            Following step 1 of ⑥ , and (1) to (3), attach the parts as original in the reverse procedure.            * Be sure to connect the capacitor lead to the specified position of the capacitor.</p>	 <p>Capacitor</p>  <p>Capacitor</p> <p>Capacitor installing leg</p> <p>Capacitor lead wire (Red)</p> <p>Capacitor lead wire (White)</p> <p>Connecting position of capacitor lead</p>



# 11-5. Floor standing concealed



MML-UP\*\*\*\*BH\*



## WARNING

Be sure to stop operation of the air conditioner before work and then turn off switch of the breaker.

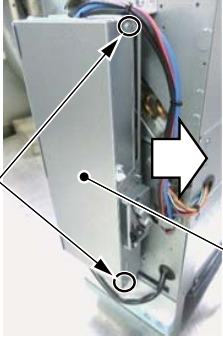
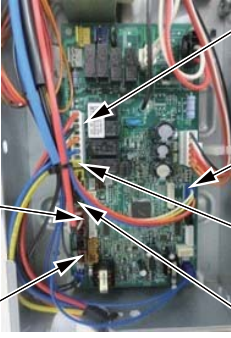
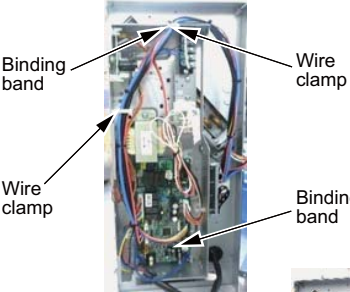
## CAUTION

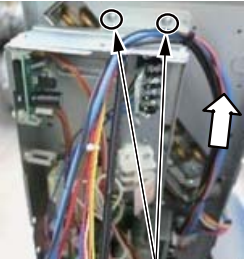
Be sure to put on gloves during working time; otherwise an injury will be caused by a part etc.

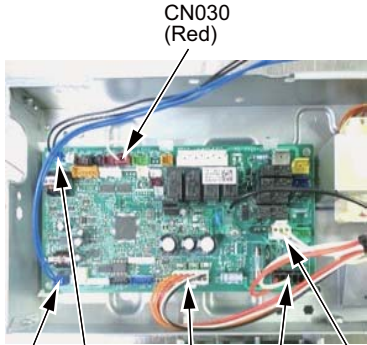

No.	Part name	Procedure	Remarks
①	Electric parts assembly	<p><b>1. Detachment</b></p> <p>(1) Remove the screws (2pcs) electric parts cover.</p> <p>(2) Slide the electric parts cover in the arrow direction to remove it.</p> <p>(3) Remove the power supply wire, remote controller wire, and communication wire between outdoor and indoor unit.</p> <p>(4) Remove following connectors from the control P.C. board.</p> <p>* Remove the connectors by unlocking the locks of the housing part.</p> <p>CN082 PMV (6P: Blue)            CN083 Fan motor (9P: White)            CN100 TC1 sensor (3P: Brown)            CN101 TC2 sensor (2P: Black)            CN102 TCJ sensor (2P: Red)            CN104 TA sensor (2P: Yellow)</p> <p>(5) Cut the binding bands (2 places) fixing the electric parts box and wires to remove the wires from the wire clamps (2 places)</p> <p>(6) Remove the screws (2 places) fixing the electric parts box and slide it upward (Arrow direction) to remove it.</p> <p><b>2. Attachment</b></p> <p>(1) Slide the electric parts assembly upper to lower to insert it into the inserting part and fix it with the screws (2 pcs).</p> <p>(2) Connect the connectors as original.</p> <p><b>NOTE</b></p> <ul style="list-style-type: none"> <li>• Check the connectors are correctly attached.</li> <li>• Be sure to check each wire is matched with each connector.</li> </ul> <p>(3) Wire the power supply wire, remote controller wire, and communication wire between outdoor and indoor unit as original.</p> <p>(4) Attach the electric parts cover.</p>	 <p>Screw</p> <p>Electric parts cover</p>  <p>CN083 (White)</p> <p>CN082 (Blue)</p> <p>CN104 (Yellow)</p> <p>CN101 (Black)</p> <p>CN100 (Brown)</p> <p>CN102 (Red)</p>  <p>Binding band</p> <p>Wire clamp</p> <p>Wire clamp</p> <p>Binding band</p>  <p>Inserting part</p>  <p>Screw</p>

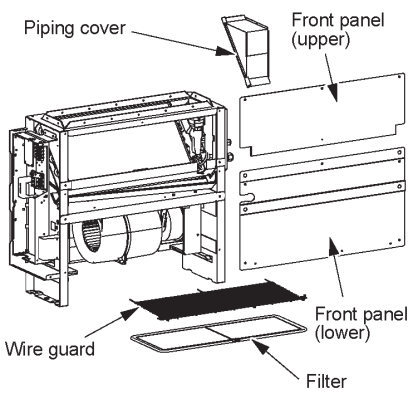
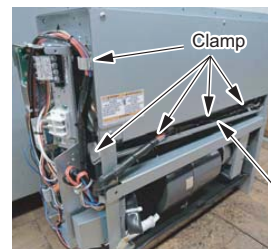
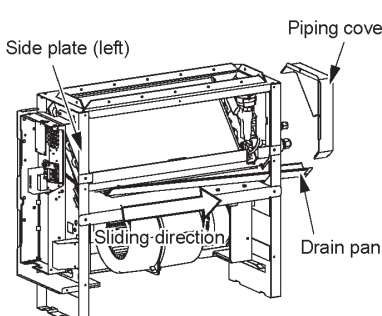
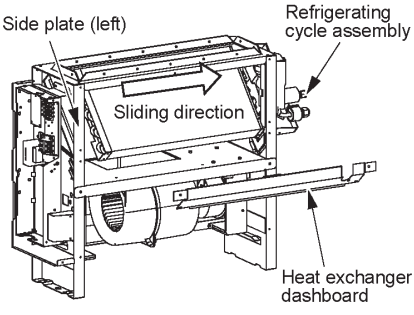
No.	Part name	Procedure	Remarks
②	Control P.C.board	<p><b>1. Detachment</b></p> <p>(1) Remove the electric parts cover.</p> <p>(2) Remove following connectors from the control P.C. board.  * Remove the connectors by unlocking the locks of the housing part.</p> <p>CN030: Short-circuit pin (3P: Red)  CN041: Terminal block for controller (2P: Blue)  CN040: Terminal block for communication wire between indoor and outdoor unit (2P:Blue)  CN030: Terminal block for power supply (5P: Black)  CN074: Power supply trance (3P: White)  CN075: Power supply trance (6P: White)</p> <p>(3) Remove locks for spacers (4 pcs) fixing the control P.C. board to remove the control P.C. board.</p> <p><b>2. Attachment</b></p> <p>(1) Attach the control P.C.board into the control P.C board as original and connect each connector</p> <p>(2) Attach the electric parts cover.</p>	 <p>CN030 (Red)</p> <p>CN041 (Blue) CN040 (Blue) CN075 (White) CN067 (Black) CN074 (White)</p>  <p>Spacer Spacer</p> <p>Spacer Spacer</p>

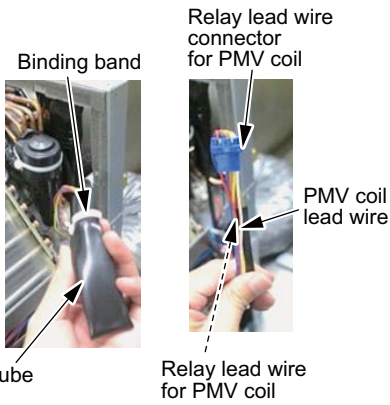
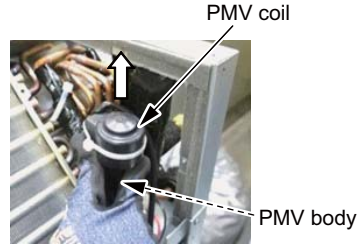
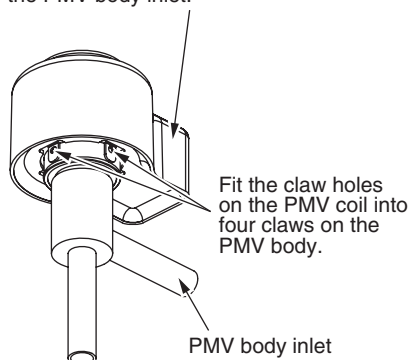
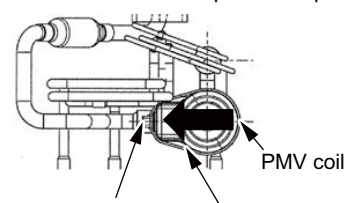

No.	Part name	Procedure	Remarks
③	Refrigerating cycle assembly	<p><b>1. Detachment</b></p> <p>(1) Recover the refrigerating gas.</p> <p>(2) Remove the connecting pipes. (Liquid pipe and gas pipe)</p> <p>(3) Following to works in 1 of ① and (1) to (5), detach the parts.</p> <p>(4) Remove the filter. (No screw fixing)</p> <p>(5) Remove the wire guard. (M4 screw UP007 to UP009 : 3 pieces, and UP012 to 024 : 4 pieces)</p> <p>(6) Remove the front panel (lower). (M4 screw UP007 to UP009 : 3 pieces, and UP012 to 024 : 4 pieces)</p> <p>(7) Remove the front panel (upper). (M4 screw UP007 to UP009 : 3 pieces, and UP012 to 024 : 4 pieces)</p> <p>(8) Remove the piping cover (Left). (M4 screw: 2 pieces)</p> <p>(9) Remove the sensor lead and the PMV lead from the clamp.</p> <p>(10) Remove the piping cover (Right). (M4 screw: 3 pieces)</p> <p>(11) Take off the screws which fix the drain pan, slide it toward right, remove the drain pan from the side plate (Left), and then draw it toward you.</p> <p>(12) Remove the dashboard of the heat exchanger. (M4 screw: 4 pieces)</p> <p>(13) Slide the heat exchanger toward right, remove the end plate of the heat exchanger from the side plate (left), and then draw away the refrigerating cycle assembly toward you.</p>	<p><b>Remarks</b></p>    
		<p><b>2. Attachment</b></p> <p>Following to the works in 1 of ③, and (1) to (13), attach the parts as original in the reverse procedure.</p>	



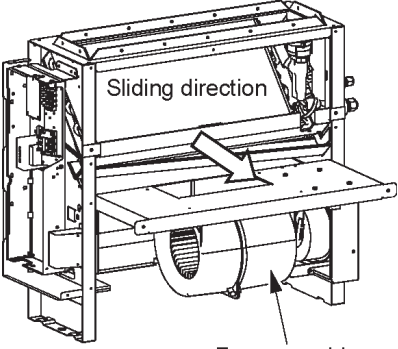

No.	Part name	Procedure	Remarks
④	PMV coil	<p><b>1. Detachment</b></p> <p>(1) Following to works of 1 of ③ and (1) to (9), detach the parts</p> <p>(2) Cut the binding band to remove the tube on the relay connector for the PMV lead wire.</p> <p>(3) Remove the relay lead wire for PMV.</p> <p>(4) Turn the PMV coil slightly while holding the PMV body so that the body does not turn, and remove the PMV coil in the arrow direction.</p> <p><b>2. Attachment</b></p> <p>(1) Attach the PMV coil as before</p> <hr/> <p><b>NOTE</b></p> <ul style="list-style-type: none"> <li>• Check the direction of the PMV coil.</li> <li>• Check the PMV coil protrusion part points to the PMV body inlet.</li> <li>• Check the claw holes in the PMV coil are securely placed into four claws on the PMV body.</li> </ul> <hr/> <p>(2) Connect relay lead wire for PMV to lead wire for PMV coli.</p> <p>(3) Wrap the connector of relay lead wire for PMV with the protective tube and fix them with the binding band.</p> <hr/> <p><b>NOTE</b></p> <p>Ensure that the connection part is placed at the bending part on the protective tube.</p> <hr/> <p>(4) Following to works of 1 of ③ and (1) to (9), attach the parts as original in the reverse procedure.</p>	<p><b>Relay lead wire connector for PMV coil</b></p>  <p><b>PMV coil</b></p>  <p>Remove the PMV coil while holding the PMV body so that the pipe does not deform.</p> <p>&lt;Installing PMV coil&gt;</p> <p>Attach the PMV coil to the PMV body so that the PMV coil protrusion part points to the PMV body inlet.</p>  <p><b>Direction of the PMV coil protrusion part.</b></p>  <p>Ensure that the lock part on the binding band comes to the position in the figure.</p>

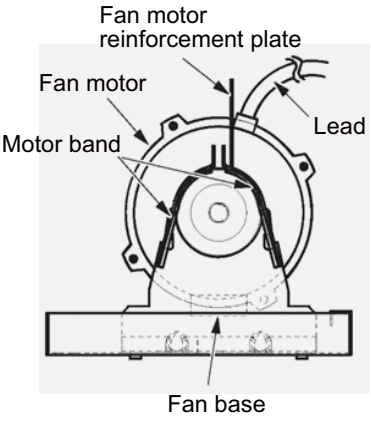
No.	Part name	Procedure	Remarks
⑤	Fan assembly	<p><b>1. Detachment</b></p> <p>(1) Following to the works in 1 of ① of (1) to (3) detach the parts.</p> <p>(2) Remove CN083 connector from the control P.C. board.</p> <p>(3) Remove the fan motor lead from the clamp.</p> <p>(4) Slide the glass tube fixing the fan motor lead and remove the connector.</p> <p>(5) Take off the fixing screws of the fan assembly and draw the fan assembly toward you. (M4 screw: 2 pieces)</p> <p><b>2. Attachment</b></p> <p>Following to the works in 1 of ①, and (1) to (5), attach the parts as original in the reverse procedure.</p>	 <p>Clamp</p> <p>Fan motor lead</p>  <p>Sliding direction</p> <p>Glass tube</p> <p>Connector</p>  <p>Sliding direction</p> <p>Fan assembly</p>

No.	Part name	Procedure	Remarks
⑥	Fan motor	<p><b>[UP007 to UP012]</b></p> <p><b>1. Detachment</b></p> <p>(1) Following to works of 1 of ⑤ and (1) to (5), detach the Fan assembly parts.</p> <p>(2) Remove the wire clamps which fixes the fan motor lead. (Two positions)</p> <p>(3) Take off the screws at the left of the fan case (4 pieces) to remove the fan case at the left</p> <p>(4) Loosen the Sirocco fan fixing screws from the discharge port to remove the Sirocco fan.</p> <p>(5) Take off two fixing screws of the fan case (Right), and remove the fan case (Right).</p> <p>(6) Take off screws (2 pieces) for capacitor cover next to the electrical parts assembly to remove the capacitor.</p> <p>(7) Remove the capacitor lead wire from the capacitor.</p> <p>(8) Take off the screws (2 pieces) fixing the motor band to remove the motor band, fan motor- reinforcement plate, and fan motor.</p>	

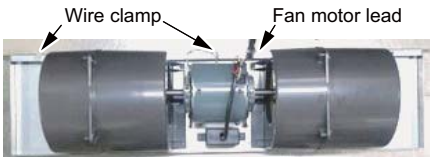
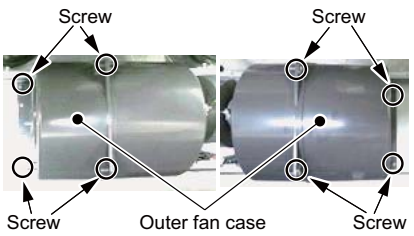
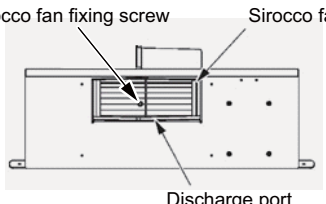
No.	Part name	Procedure	Remarks
⑥	Fan motor (Continued)	<p><b>2. Attachment</b></p> <p>(1) Attach the fan motor, motor band, fan motor reinforcement plate, and fan case as original.</p> <ul style="list-style-type: none"> <li>* When attaching the fan motor, be sure that the fan motor does not hit the motor base reinforcement plate.</li> <li>* When attaching the fan motor reinforcement plate, fasten it together with the motor band.</li> <li>* When attaching the Sirocco fan, meet the fixing screw for Sirocco fan to the notch position on the shaft of the fan motor.</li> <li>* When fixing the Sirocco fan, ensure that the Sirocco fan does not hit to the fan case.</li> <li>* For the tightening torque of the screw fixing the Silocco fan, control between 5.0 to 5.2 N•m.</li> </ul> <p>(2) Following to the works in 1 of ⑤, and (1) to (3), attach the Fan assembly parts as original in the reverse procedure.</p>	 <p>The diagram shows a cross-section of the fan motor assembly. Labels include: Fan motor reinforcement plate (top), Fan motor (center), Motor band (curved around the motor), Lead wire (connected to the motor), and Fan base (bottom). Dashed lines indicate the internal components and their alignment.</p>  <p>The close-up image shows the shaft of the Sirocco fan with a notch. A fixing screw is being inserted into the shaft. Labels include: Fixing screw for sirocco fan and Shaft.</p> <p><u>Ensure that the notch on the shaft meets to the position of the fixing screw for sirocco fan.</u></p>

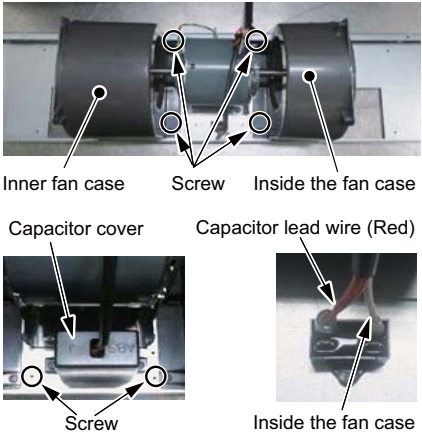
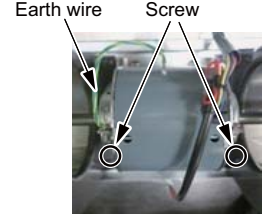
No.	Part name	Procedure	Remarks
⑥	Fan motor (Continued)	<p><b>[UP015 to UP024]</b></p> <p><b>1. Detachment</b></p> <p>(1) Following to works of 1 of ⑤ and (1) to (5), detach the Fan assembly parts.</p> <p>(2) Remove the wire clamps which fixes the fan motor lead. (Two positions).</p> <p>(3) Take off the screws (8 pcs) for outer fan case (2pcs) to the fan motor and remove the tape for inner fan case to remove the outer fan case.</p> <p>(4) Take off the screws (4 pcs) for inner fan case to remove the inner fan case.</p> <p>(5) Take off screws (2 pieces) for capacitor cover to remove the capacitor cover.</p> <p>(6) Remove the capacitor lead wire from the capacitor.</p> <p>(7) Take off the screws (2 pieces) fixing the motor band to remove the motor band, fan motor-reinforcement plate, and fan motor.</p> <p><b>2. Attachment</b></p> <p>(1) Attach the fan motor, motor band, and fan case as original.</p> <ul style="list-style-type: none"> <li>* When attaching the Sirocco fan, meet the fixing screw for Sirocco fan to the notch position on the shaft of the fan motor.</li> <li>* When fixing the Sirocco fan, ensure that the Sirocco fan does not hit to the fan case.</li> <li>* For the tightening torque of the screw fixing the Sirocco fan, control between 5.0 to 5.2 N·m.</li> <li>* When connecting the capacitor, be careful of its connection position.</li> </ul> <p>(2) Following to the works in 1 of ⑤, and (1) to (5), attach the Fan assembly parts as original in the reverse procedure.</p>	 <p>Wire clamp      Fan motor lead</p>  <p>Screw      Screw</p> <p>Screw      Outer fan case      Screw</p>  <p>Sirocco fan fixing screw      Sirocco fan</p> <p>Discharge port</p>  <p>Tape</p>  <p>Inner fan case      Screw      Inside the fan case</p> <p>Capacitor cover      Capacitor lead wire (Red)</p> <p>Screw      Inside the fan case</p>  <p>Earth wire      Screw</p>

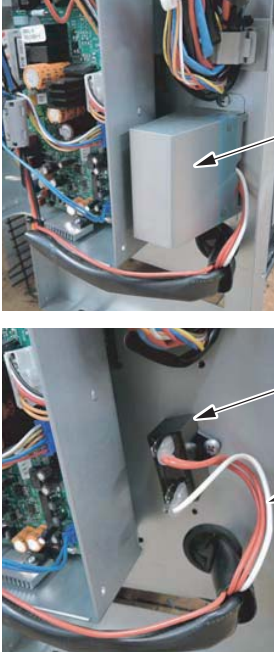
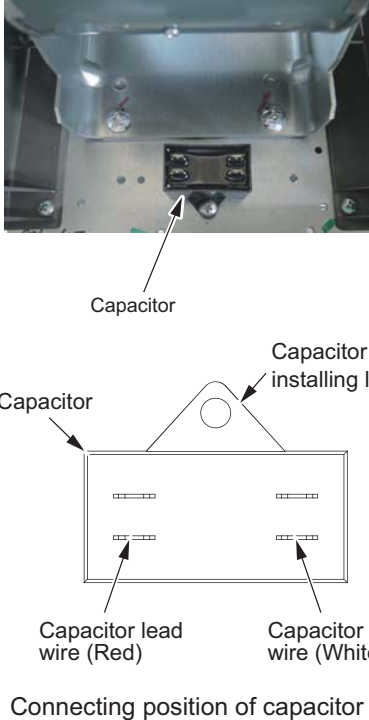
No.	Part name	Procedure	Remarks
⑦	Capacitor	<p><b>[UP007 to UP012]</b></p> <p><b>1. Detachment</b></p> <p>(1) Following to ,1 of ①, and (1) to (2), detach the parts.</p> <p>(2) Remove the capacitor cover and remove the capacitor lead from the capacitor. (M4 screw: 2 pieces)</p> <p>(3) Remove the capacitor. (M4 screw: 1 position)</p> <p><b>2. Attachment</b></p> <p>Following to 1 of ①, and (1) to (2), attach the parts as original in the reverse procedure.</p>	 <p>Capacitor cover</p> <p>Capacitor</p> <p>Capacitor lead</p>
		<p><b>[UP015 to UP024]</b></p> <p><b>1. Detachment</b></p> <p>(1) Following to ,1 of ⑦, and (1) to (2), detach the parts. (M4 screw: 2 pieces)</p> <p>(2) Remove the capacitor. (M4 screw: 1 position)</p> <p><b>2. Attachment</b></p> <p>Following to 1 of ⑦, and (1) to (2), attach the parts as original in the reverse procedure.</p> <p><b>[UP007 to UP024]</b></p> <p>* Be sure to connect the capacitor lead to the specified position of the capacitor.</p>	 <p>Capacitor</p> <p>Capacitor</p> <p>Capacitor installing leg</p> <p>Capacitor lead wire (Red)</p> <p>Capacitor lead wire (White)</p> <p>Connecting position of capacitor lead</p>

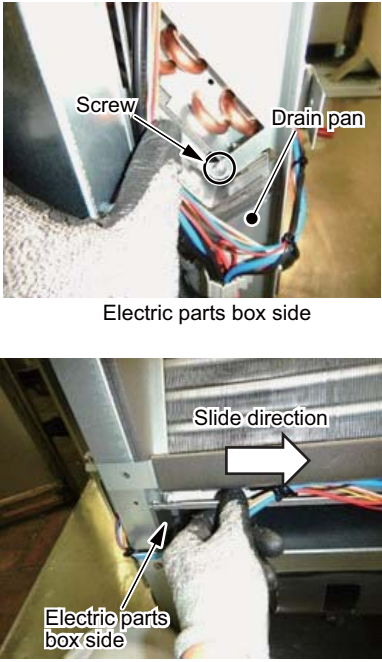
No.	Part name	Procedure	Remarks
⑧	Drain pan	<p><b>1. Detachment</b></p> <p>(1) Remove the front panel (lower) and electric parts assembly. Refer to the works of 1 of ③ and (6), and the work of 1 of ①.</p> <p>(2) Remove the screws fixing the drain pan</p> <p>(3) Slide the drain pan in the direction of piping side to remove it.</p> <p><b>2. Attachment</b></p> <p>(1) Attach the drain pan as original and tighten it with screws.</p> <p>(2) Attach the front panel (lower) and electric parts assembly. Refer to the works of 2 of ② and (6), and the work of 2 of ①.</p>	 <p>The top photograph shows a close-up of the drain pan assembly. A screw is being removed from the drain pan, which is attached to the electric parts box side. Labels include 'Screw' and 'Drain pan'. Below the photo is the text 'Electric parts box side'.</p> <p>The bottom photograph shows a person's hands sliding the drain pan in the direction of the piping side. A white arrow indicates the 'Slide direction'. Labels include 'Slide direction' and 'Electric parts box side'.</p>

# 11-6. Floor standing

MMF-UP\*\*\*\*H\*

## WARNING



Be sure to stop operation of the air conditioner before work and then turn off switch of the breaker.

## CAUTION

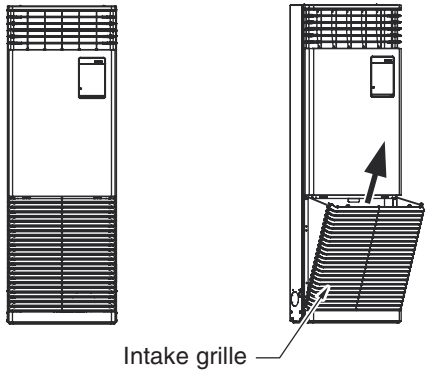
Be sure to put on gloves during working time; otherwise an injury will be caused by a part etc.

No.	Part name	Procedure	Remarks
①	Intake grille	<p><b>1. Detachment</b></p> <p>1) Pull the upper part of the intake grille toward you, remove two strings that connect the intake grille with the main unit, and then remove the intake grille while lifting up it.</p> <p><b>2. Attachment</b></p> <p>1) Attach the intake grille in the reverse way of detachment.</p>	 <p>Intake grille</p>

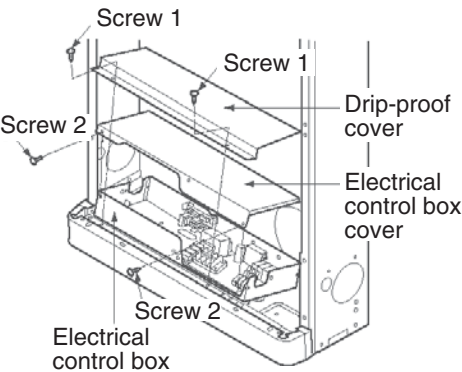
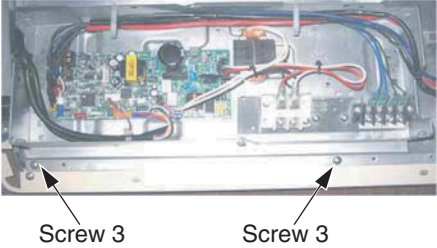

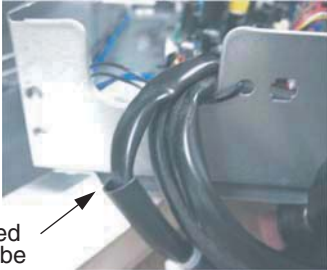
No.	Part name	Procedure	Remarks
②	Electric parts box	<p><b>1. Detachment</b></p> <ol style="list-style-type: none"> <li>1) Carry out the work of item ①-1.</li> <li>2) Remove the Screw 1 (two screws) from the drip-proof cover on the bottom plate. * This work is unnecessary for Models UP036 to UP056.</li> <li>3) Remove the Screw 2 (two screws) from the electrical control box cover.</li> <li>4) Remove the indoor/outdoor communication wires and the remote controller wires from each terminal block.</li> <li>5) Remove the connectors and others which connected to P.C. board.</li> </ol> <p><b>NOTE</b></p> <hr/> <p>When removing the connectors, unlock the lock.</p> <p>CN01 : Reactor (3P, Blue)  CN40 : Indoor/Outdoor communication terminal block (2P, Blue)  CN41 : Remove controller terminal block (2P, Blue)  CN67 : Power supply terminal block (5P: Black)  CN82 : PMV output (6P, Blue)  CN100: TC1 sensor (3P, Brown)  CN101: TC2 sensor (2P, Black)  CN102: TCJ sensor (2P, Red)  CN104: Room temperature (2P, Yellow)  CN210: Fan motor (7P, White)  CN510: Louver motor (20P, White)</p> <ol style="list-style-type: none"> <li>6) Remove the Screw 3 (two screws) that fix the electric parts box, slide it toward right, and then remove the electric parts box.</li> <li>7) Unlock the lock of the card edge spacer, and then remove the P.C. board.</li> </ol> <p><b>2. Attachment</b></p> <ol style="list-style-type: none"> <li>1) Attach the P.C. board and the electric parts box, and then perform wiring as before.</li> <li>2) Attach the electrical control box cover and the drip-proof cover.</li> </ol> <p><b>NOTE</b></p> <hr/> <ul style="list-style-type: none"> <li>• Check there is no incorrect wiring or no dislocation of connector.</li> <li>• Set the connected part of tube of the fan motor lead wire at a place out of the electric parts box.</li> </ul> <hr/>	  <p>P.C. board</p>  

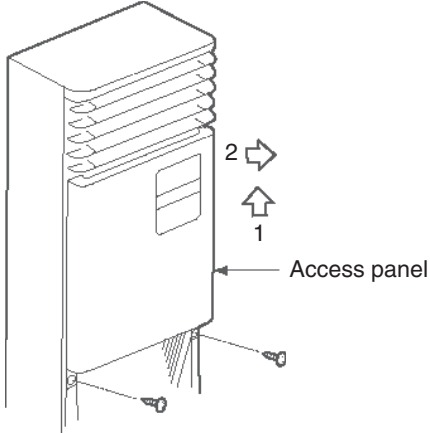
No.	Part name	Procedure	Remarks
③	Access panel	<p><b>1. Detachment</b></p> <p>1) Carry out the work of item ①-1.</p> <p>2) Remove the two screws of the Access panel, slide the Access panel approx. 30mm upward, and remove the Access panel while drawing it toward you.</p> <ul style="list-style-type: none"> <li>• The screws are designed to stay on the Access panel.</li> </ul> <p><b>2. Attachment</b></p> <p>1) Attach the Access panel in the reverse way of detachment, and then fix it with two screws.</p> <p><b>⚠ CAUTION</b></p> <p>For reason of safety, be sure to fix the Access panel with screws.</p>	

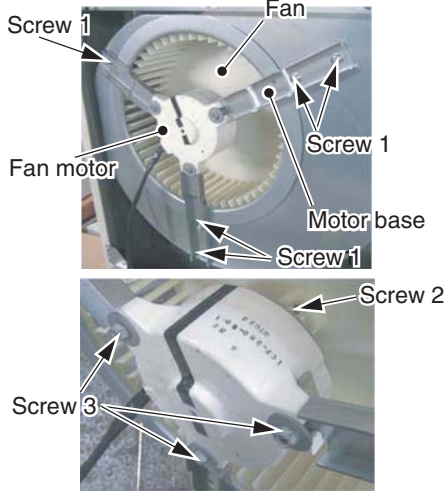
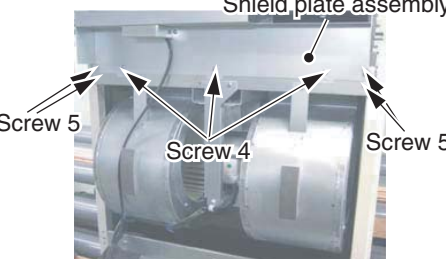
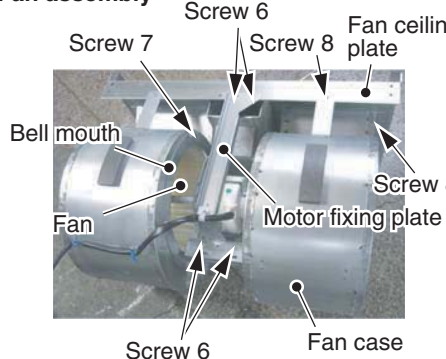
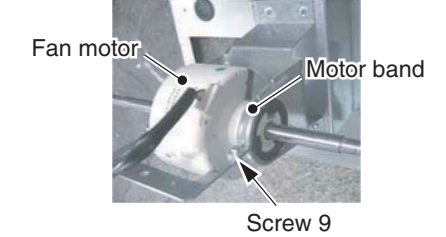
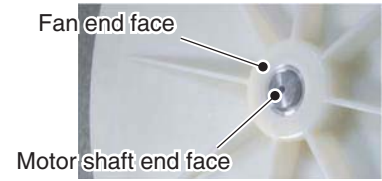
No.	Part name	Procedure	Remarks
④	Fan, Fan motor	<p><b>1. Detachment</b></p> <p>1) Carry out the works of items ①-1 and ③-1.</p> <p>2) Cut off the banding band that fixes the fan motor lead wire to remove the fan motor connector in the electric parts box.</p> <p><b>▼ UP015 ~ UP027</b></p> <p>3) Remove the Screw 1 (five screws) that fix the motor base, fan motor, and fan.</p> <p>4) Loosen the Screw 2 that fixes the fan and then remove the fan.</p> <p>5) Remove the Screw 3 (three screws) and then remove the fan motor.</p> <p><b>▼ UP036 ~ UP056</b></p> <p>3) Remove the Screw 4 (three screws) that fix the shield plate assembly, and then remove the shield plate assembly.</p> <p>4) Remove the Screw 5 (five screws) that fix the ceiling plate of the fan assembly, and then draw out the fan with assembly.</p> <p>5) Remove the Screw 6 (four screws) that fix the motor fixing plate, and then remove the motor fixing plate.</p> <p>6) Remove the Screw 7 (four screws for left and right each) that fixes right and left bell-mouth, take off left and right fan case fixing Screw 8 (four screws for left and right), and then remove the fan case.</p> <p>7) Remove the screw that fixes the fan, and then remove the fan from the fan motor.</p> <p>8) Remove the Screw 9 (the screw for right and left each) of the left and right motor band, and then remove the fan motor.</p> <p><b>2. Attachment</b></p> <p>1) Attach the fan motor, fan and others in the reverse way of detachment, and then perform wiring as before.</p> <p><b>NOTE</b></p> <hr/> <ul style="list-style-type: none"> <li>• Mount UP015 to UP027 fans so that bump difference when putting motor shaft end face and fan end face together is within <math>\pm 1</math>mm.</li> <li>• For attachment of UP036 to UP056 fans, set so that the fan locates at the center of the fan case.</li> <li>• Tighten the fan screw with 4.9N•m or more with a torque wrench.</li> </ul> <hr/>	<p><b>&lt;UP015 to UP027&gt;</b></p>  <p><b>&lt;UP036 to UP056&gt;</b></p>  <p><b>Fan assembly</b></p>   <p><b>&lt;UP015 to UP027&gt;</b></p> 

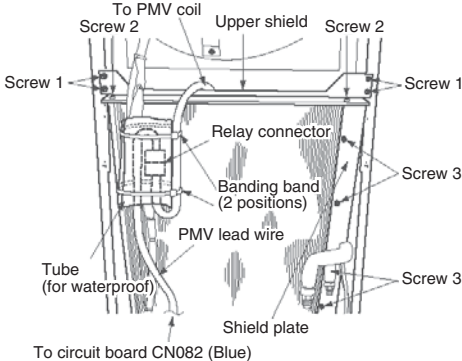
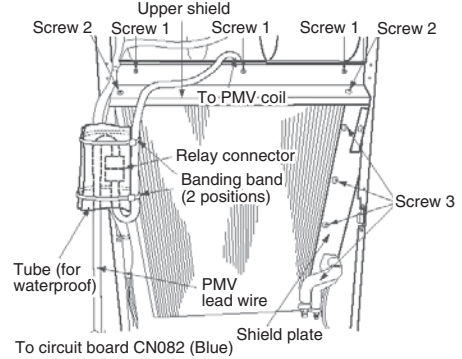
No.	Part name	Procedure	Remarks
⑤	Heat exchanger	<p><b>1. Detachment</b></p> <p>1) Carry out the works of items ①-1 and ③-1.</p> <p>▼ <b>UP015 to UP027</b></p> <p>2) Remove the tube of the relay part of PMV, and then remove the relay connector.</p> <p>3) Remove the Screw 1 (four screws) that fixes the main unit and heat exchanger assembly, and then draw out the heat exchanger assembly toward you.</p> <p>4) Remove the Screw 2 (two screws) of the heat exchanger, and then remove the upper shield plate.</p> <p>5) Remove the Screw 3 (four screws) of the heat exchanger assembly, and then remove the shield plate.</p> <p>6) Remove three types of temperature sensors from the heat exchanger assembly.</p> <p>▼ <b>UP036 to UP056</b></p> <p>2) Remove the tube of the PMV relay part to remove the relay connector.</p> <p>3) Remove the Screw 1 (three screws) that fixes the main unit and the heat exchanger assembly, and then draw out the heat exchanger assembly toward you.</p> <p>4) Remove the Screw 2 (two screws) of the heat exchanger assembly, and then remove the upper shield plate.</p> <p>5) Remove the Screw 3 (four screws) of the heat exchanger assembly, and then remove the shield plate.</p> <p>6) Remove three types of the temperature sensors from the heat exchanger assembly.</p> <p><b>2. Attachment</b></p> <p>1) Attach the temperature sensor, shield plate, and heat exchanger assembly in the reverse way of the detachment, and then perform wiring of PMV relay lead wire as before.</p>	<p><b>&lt;UP015 to UP027&gt;</b></p>  <p><b>&lt;UP036 to UP056&gt;</b></p> 

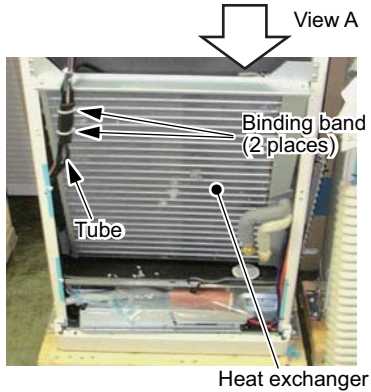
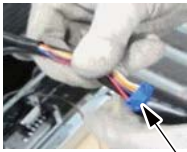
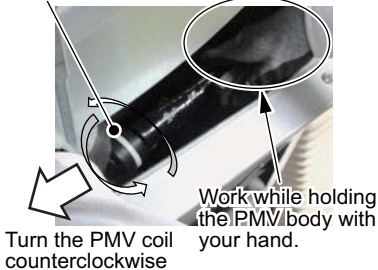
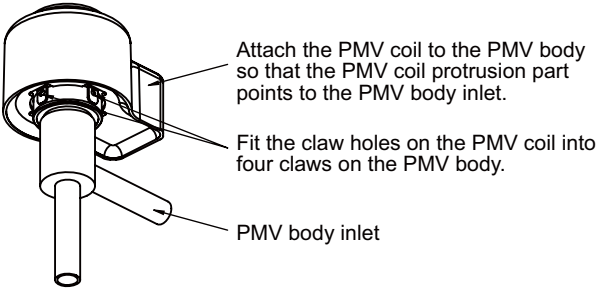
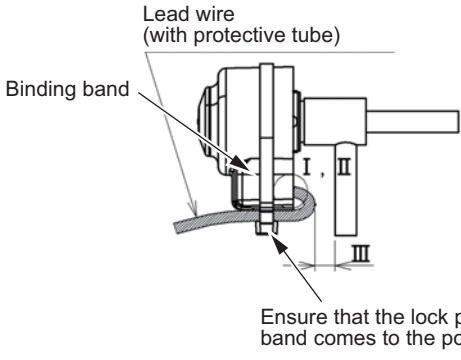
No.	Part name	Procedure	Remarks
⑥	PMV coil	<p><b>1. Detachment</b></p> <p>(1) Carry out the works items ⑤-1.</p> <p>(2) Cut the binding bands (2 places) to remove the tube of the relay part of PMV.</p> <p>(3) Remove the PMV lead from the relay connector</p> <p>(4) Turn the PMV coil slightly clockwise while holding the PMV body so that the body does not turn, and remove it in the arrow direction.</p> <p><b>2. Attachment</b></p> <p>(1) Attach the PMV coil as before and check it does not move.</p> <hr/> <p><b>NOTE</b></p> <ul style="list-style-type: none"> <li>• Check the direction of the PMV coil.</li> <li>• Check the claw holes in the PMV coil are securely placed into four claws on the PMV body.</li> <li>• Check position of the lock part on the binding band and the lead wires.</li> </ul> <hr/> <p>(2) Connect the PMV lead wire to the relay connector of PMV.</p> <p>(3) Attach the tube as before and fix it with the binding band (2 place).</p>	<p><b>View A</b></p>    <p><b>View A</b></p>   <p>Caution when fixing the lead wire with the binding band.</p> <p>I . Do not apply tension to the drawing part on the coil lead wire.</p> <p>II . Insert the protective tube up to the root of drawing part on the lead wire.</p> <p>III . Ensure that the PMV pipe does not come to contact with the protective tube.</p>

No.	Part name	Procedure	Remarks
⑦	Horizontal louver	<p><b>1. Detachment</b></p> <p>(1) Remove the intake grille and the access panel. (Carry out the works items ①-1 and ③-1.)</p> <p>(2) Remove three screws that fixes the shield plate assembly to remove the shield plate assembly.</p> <p>(3) Remove two screws that fixes the discharge grille assembly. Draw the discharge grille toward you while lifting it upward slightly to remove it. * Be careful not to lose the supporting plate.</p> <p>(4) Turn the horizontal louver in the vertical direction and draw it toward you to remove it from the discharge grille frame</p> <p>(5) Remove the horizontal louver from the center clamp. (five places at the center) * Lift the horizontal louver to diagonally upward.</p> <p>(6) Remove the horizontal louver from the louver joint (five places).</p> <p><b>2. Attachment</b></p> <p>(1) Carry out reversing the detachment procedure, attaching the horizontal louver. * Apply the grease to the receptor of axis (five places) when replacing the center clamp. (Recommended grease : Shinetsu Silicone HIVAC-G)</p>	



# 12. EXPLODED VIEWS AND PARTS LIST

## 12-1. Compact 4-way cassette type

MMU-UP0051MH-E(TR), UP0071MH-E(TR), UP0091MH-E(TR), UP0121MH-E(TR),  
UP0151MH-E(TR), UP0181MH-E(TR)

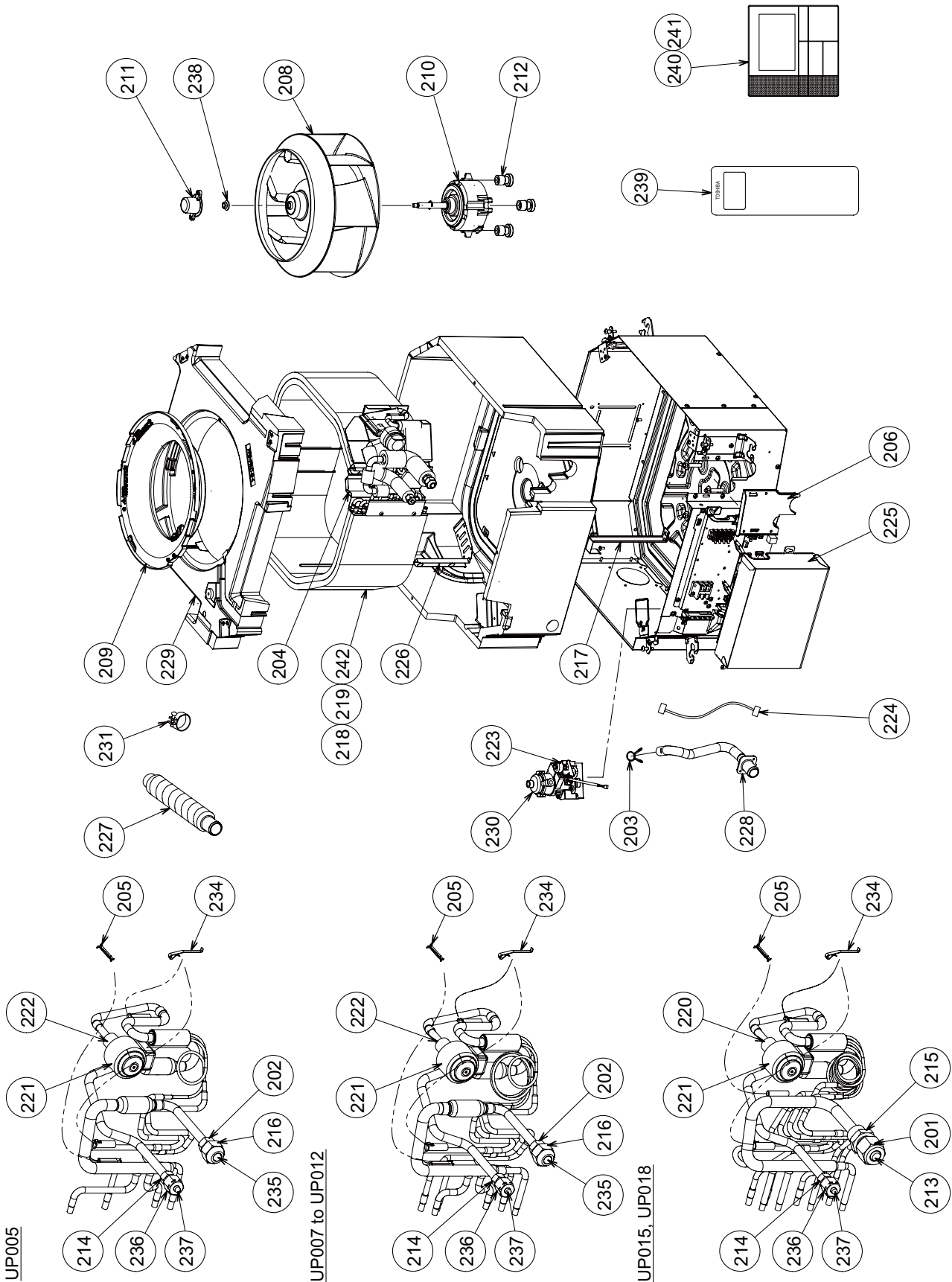

Location No.	Part No.	Description	Q'ty/Set MMU-UP					
			0051MH -E (TR)	0071MH -E (TR)	0091MH -E (TR)	0121MH -E (TR)	0151MH -E (TR)	0181MH -E (TR)
201	43047688	NUT, FLARE, 12.7					1	1
202	43049776	SOCKET, 9.52	1	1	1	1		
203	43079249	BAND, HOSE	1	1	1	1	1	1
204	43104248	PLATE ASSY, PARTITION	1	1	1	1	1	1
205	43107215	HOLDER, SENSOR	1	1	1	1	1	1
206	43119542	COVER, PIPE	1	1	1	1	1	1
208	43120277	FAN, ASSY TURBO	1	1	1	1	1	1
209	43122165	BELL MOUTH	1	1	1	1	1	1
210	4312C193	MOTOR, FAN, ICF-340D60-1 N	1	1	1	1	1	1
211	43139166	CAP, NUT	1	1	1	1	1	1
212	43139187	RUBBER, CUSHION	3	3	3	3	3	3
213	43147195	BONNET, 12.7					1	1
214	43149351	SOCKET, 6.35	1	1	1	1	1	1
215	43149353	SOCKET, 12.7					1	1
216	43149355	NUT, FLARE, 9.52	1	1	1	1		
217	43149533	BAND, FIX, EVAPORATOR	1	1	1	1	1	1
218	4314J633	REFRIGERATION CYCLE ASSY					1	1
219	4314J634	REFRIGERATION CYCLE ASSY		1	1	1		
220	4314N202	BODY, PMV, PAM-B40YGTF-1					1	1
221	4314N205	COIL, PMV, PAM-MD12TF-301	1	1	1	1	1	1
222	4314N210	BODY, PMV, PAM-B25YGTF-1	1	1	1	1		
223	43151323	SWITCH, FLOAT	1	1	1	1	1	1
224	43160663	LEAD, RELAY	1	1	1	1	1	1
225	43162087	COVER, E-BOX	1	1	1	1	1	1
226	43163052	HOLDER, LEAD, FAN MOTOR	1	1	1	1	1	1
227	43170276	HOSE, DRAIN	1	1	1	1	1	1
228	43170277	HOSE, DRAIN	1	1	1	1	1	1
229	43172259	PAN ASSY, DRAIN	1	1	1	1	1	1
230	43177029	PUMP, DRAIN	1	1	1	1	1	1
231	43179170	BAND, HOSE	2	2	2	2	2	2
234	43F19904	HOLDER, SENSOR (TS)	2	2	2	2	2	2
235	43F47609	BONNET, 9.52	1	1	1	1		
236	43F47685	NUT, FLARE, 9.52	1	1	1	1	1	1
237	43F49697	BONNET, 6.35	1	1	1	1	1	1
238	43F97212	NUT	1	1	1	1	1	1
239	43166041	REMOTE CONTROLLER, WIRELESS, RBC-AXU31-E	1	1	1	1	1	1
240	43166042	REMOTE CONTROLLER, WIRED, RBC-AMSU51-EN	1	1	1	1	1	1
241	43166043	REMOTE CONTROLLER, WIRED, RBC-AMSU51-ES	1	1	1	1	1	1
242	4314J668	REFRIGERATION CYCLE ASSY	1					



## Electric Parts

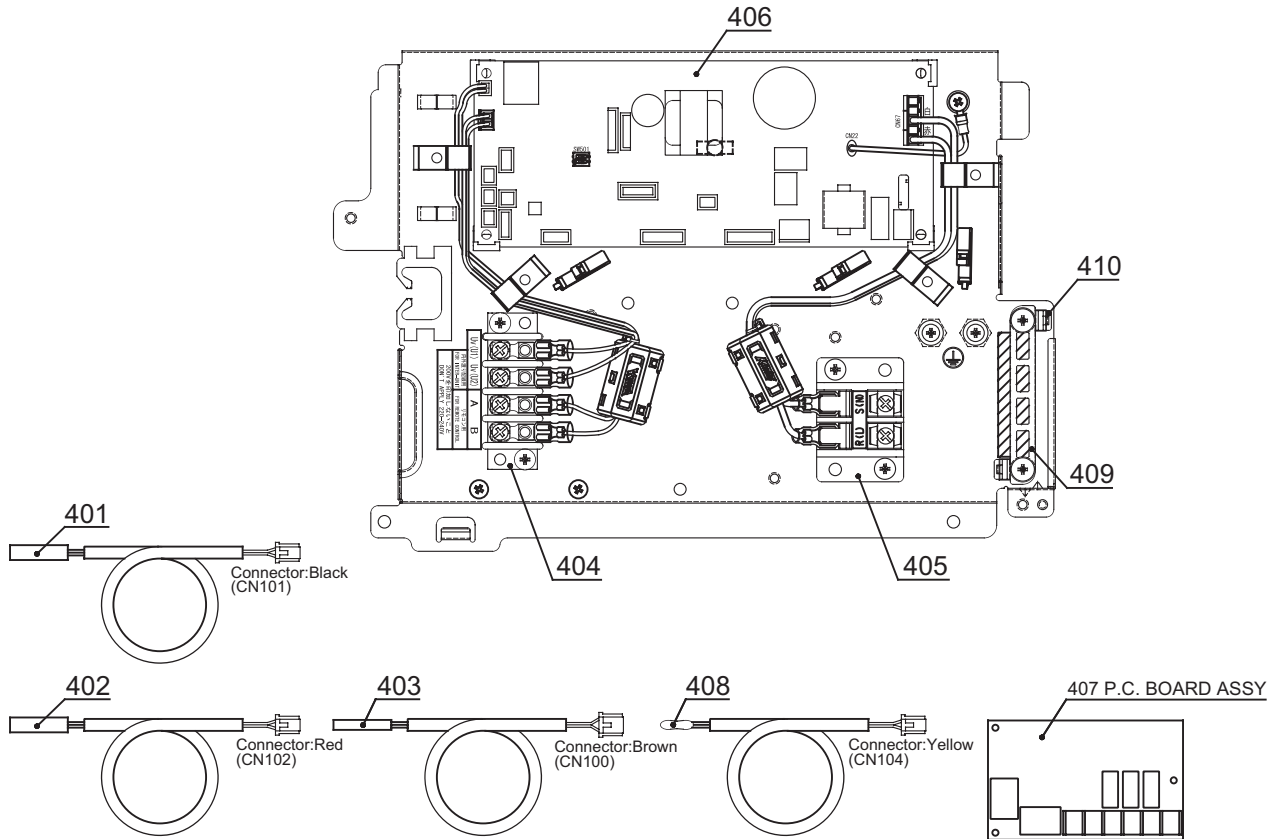

Location No.	Part No.	Description	Q'ty/Set
			MMU-UP0**1MH-E(TR)
401	43150394	SENSOR	1
402	43150395	SENSOR	1
403	43150417	SENSOR, TEMP	1
404	43160694	TERMINAL, 4P	1
405	43160626	TERMINAL BLOCK, 2P, 20A	1
406	4316V727	P.C. BOARD ASSY, MCC-1643	1
407	43459017	P.C. BOARD ASSY, TCB-PCUC*E	1
408	43150423	SENSOR, TA	1
409	43163057	CLAMP, DOWN	1
410	43163058	CLAMP, UP	1

## ◆ Ceiling panel

RBC-UM21PG (W)-E

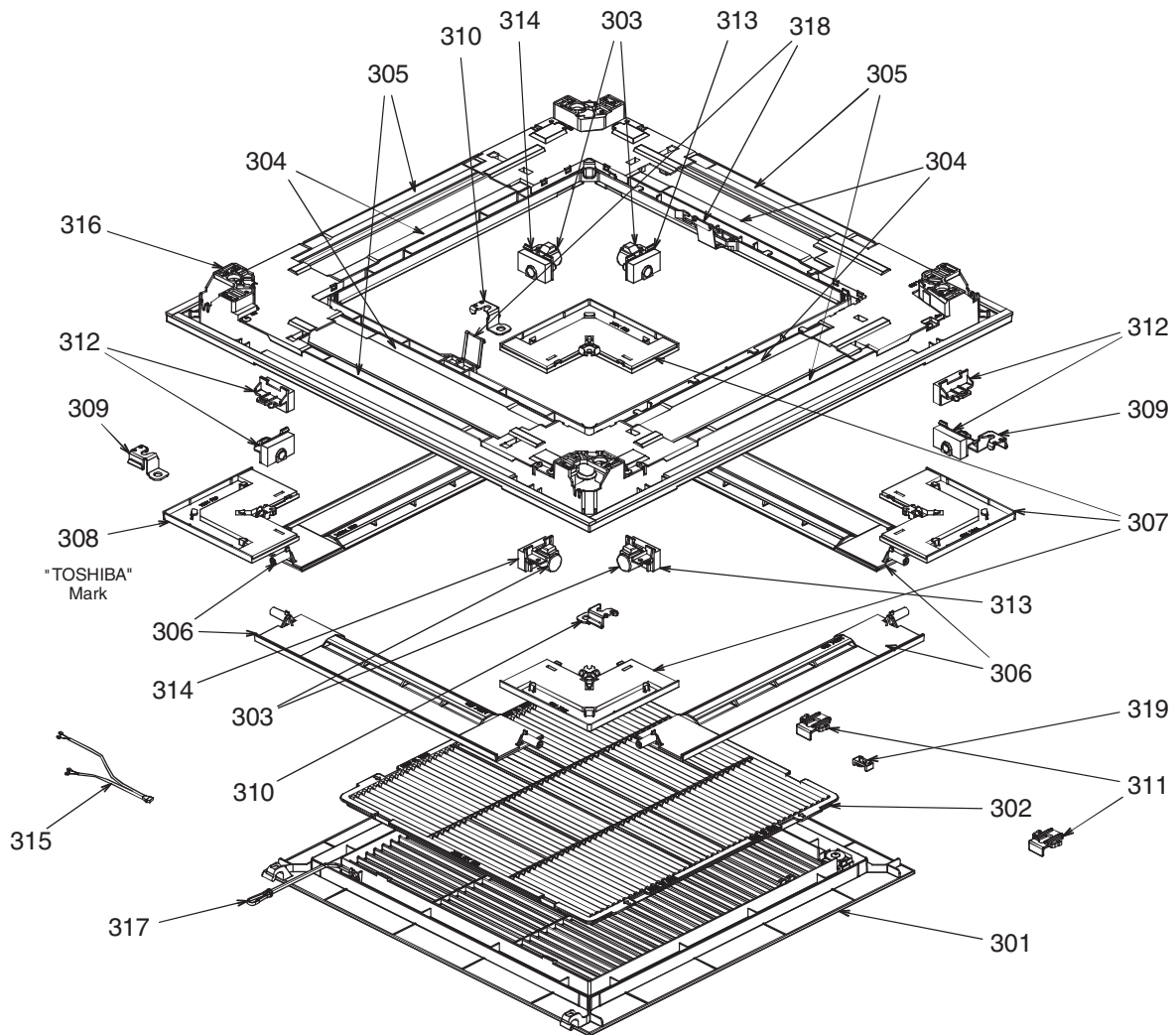

Location No.	Part No.	Description	Q'ty/Set
301	43109441	GRILLE, AIR INLET	1
302	43180361	AIR FILTER	1
303	4342D001	MOTOR, LOUVER, MSBPC20F04	4
304	43107296	OUTLET, AIR FORM	4
305	43107297	OUTLET, AIR FORM	4
306	43122166	LOUVER ASSY	4
307	4310A142	COVER, PANEL ASSY	3
308	4310A143	COVER, PANEL ASSY	1
309	43107298	PLATE, FIX PANEL (A)	2
310	43107299	PLATE, FIX PANEL (B)	2
311	43107300	HOOK	2
312	43107301	CAP, AXIS	4
313	43107302	FIX, MOTOR ASSY	2
314	43107303	FIX, MOTOR ASSY	2
315	43160664	LEAD, MOTOR	1
316	4310A144	PANEL, HINS ASSY	1
317	43419022	STRING	1
318	43107304	HANGER	2
319	43107305	FIX, GRILLE	1

# 12-2. 2-way cassette type

MMU-UP0071WH-E(TR), UP0091WH-E(TR), UP0121WH-E(TR), UP0151WH-E(TR)

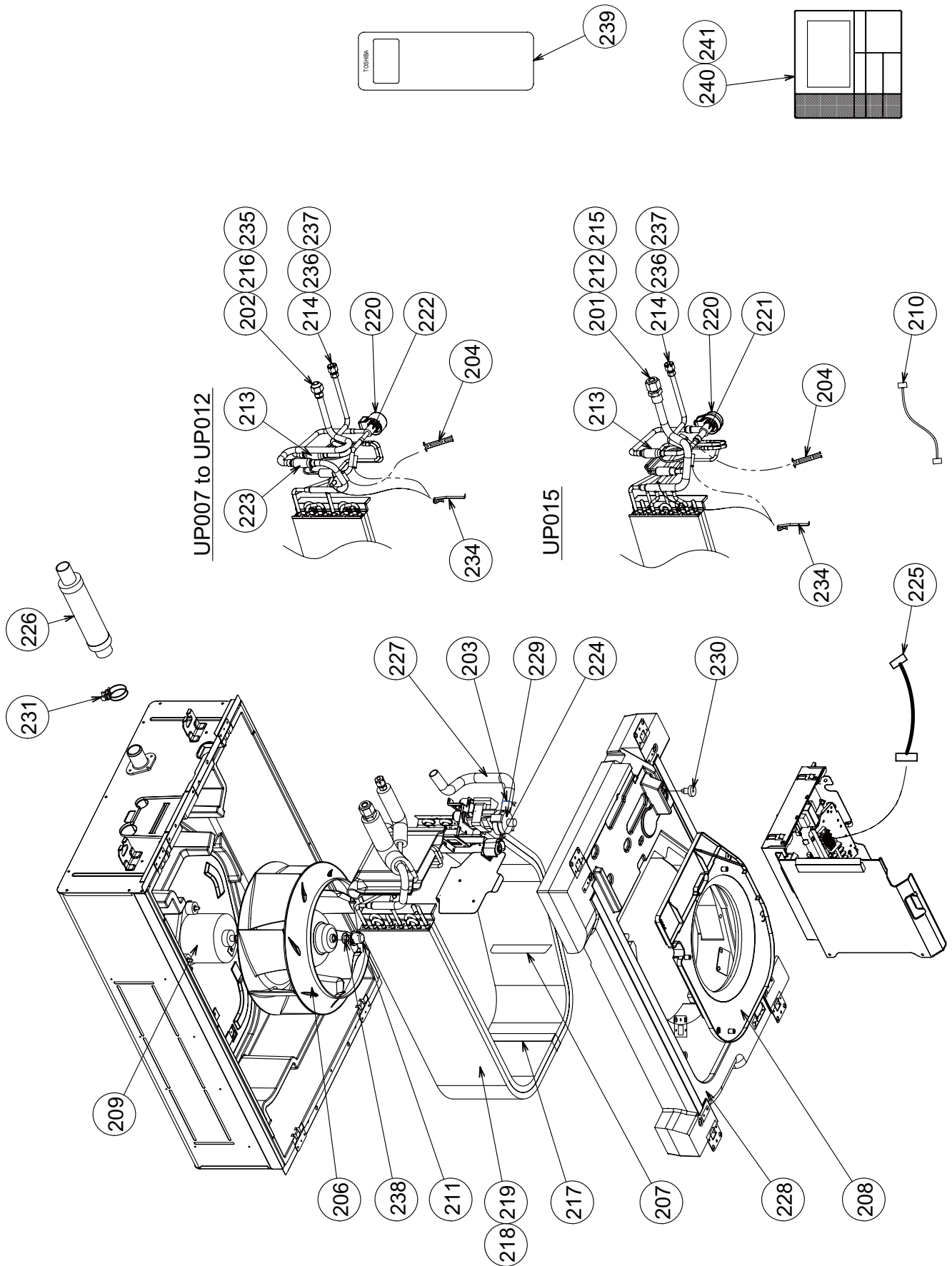

Location No.	Part No.	Description	Q'ty/Set		MMU-UP	
			0071WH -E (TR)	0091WH -E (TR)	0121WH -E (TR)	0151WH -E (TR)
201	43047688	NUT, FLARE, 12.7				1
202	43049776	SOCKET, 9.52	1	1	1	
203	43079249	BAND, HOSE	1	1	1	1
204	43107215	HOLDER, SENSOR	1	1	1	1
206	43120225	FAN, ASSY TURBO	1	1	1	1
207	43122099	PLATE, WIND	3	3	3	3
208	43122100	BELL MOUTH	1	1	1	1
209	4312C192	MOTOR, FAN, ICF-340D60-1	1	1	1	1
210	43135022	CONNECTOR ASSY, PMV	1	1	1	1
211	43139166	CAP, NUT	1	1	1	1
212	43147195	BONNET, 12.7				1
213	43147664	STRAINER, 9.52	1	1	1	1
214	43149351	SOCKET, 6.35	1	1	1	1
215	43149353	SOCKET, 12.7				1
216	43149355	NUT, FLARE, 9.52	1	1	1	
217	43149534	BAND, FIX, EVAPORATOR	1	1	1	1
218	4314J635	REFRIGERATION CYCLE ASSY	1	1	1	
219	4314J636	REFRIGERATION CYCLE ASSY				1
220	4314N205	COIL, PMV, PAM-MD12TF-301	1	1	1	1
221	4314N209	BODY, PMV, PAM-B40YGTF-2				1
222	4314N210	BODY, PMV, PAM-B25YGTF-1	1	1	1	
223	4314Q051	STRAINER, 12.7	1	1	1	
224	43151328	SWITCH, FLOAT, FS-0218-103	1	1	1	1
225	43160691	LEAD, CONN	1	1	1	1
226	43170244	HOSE, DRAIN	1	1	1	1
227	43170289	HOSE, DRAIN	1	1	1	1
228	43172191	PAN ASSY, DRAIN	1	1	1	1
229	43177028	PUMP, DRAIN, PMD-08D12TF-2	1	1	1	1
230	43179110	PLUG	1	1	1	1
231	43179163	BAND, HOSE	1	1	1	1
234	43F19904	HOLDER, SENSOR (TS)	2	2	2	2
235	43F47609	BONNET, 9.52	1	1	1	
236	43F47685	NUT, FLARE, 6.35	1	1	1	1
237	43F49697	BONNET, 6.35	1	1	1	1
238	43F97212	NUT	1	1	1	1
239	43166041	REMOTE CONTROLLER, WIRELESS, RBC-AXU31-E	1	1	1	1
240	43166042	REMOTE CONTROLLER, WIRED, RBC-AMSU51-EN	1	1	1	1
241	43166043	REMOTE CONTROLLER, WIRED, RBC-AMSU51-ES	1	1	1	1

MMU-UP0181WH-E(TR), UP0241WH-E(TR), UP0271WH-E(TR), UP0301WH-E(TR)

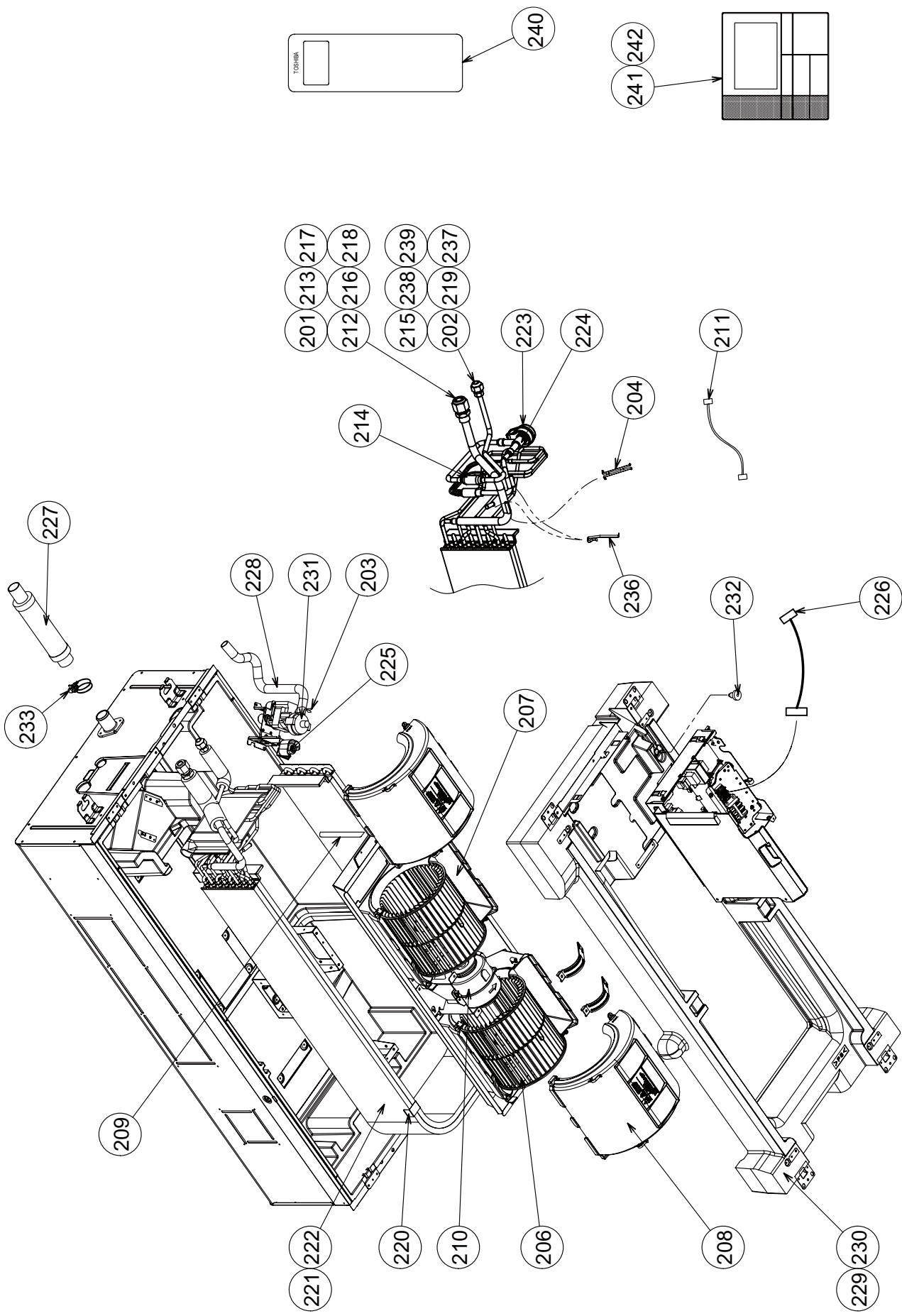

Location No.	Part No.	Description	Q'ty/Set		MMU-UP	
			0181WH -E (TR)	0241WH -E (TR)	0271WH -E (TR)	0301WH -E (TR)
201	43047688	NUT, FLARE, 12.7	1			
202	43049776	SOCKET, 9.52		1	1	1
203	43079249	BAND, HOSE	1	1	1	1
204	43107215	HOLDER, SENSOR	1	1	1	1
206	43120239	FAN, MULTI BLADE	2	2	2	2
207	43122097	CASE, FAN	2	2	2	2
208	43122098	CASE, FAN	2	2	2	2
209	43122099	PLATE, WIND	4	4	4	4
210	4312C183	MOTOR, FAN, ICF-340WD94-9	1	1	1	1
211	43135022	CONNECTOR ASSY, PMV	1	1	1	1
212	43147194	BONNET, 15.88		1	1	1
213	43147195	BONNET, 12.7	1			
214	43147664	STRAINER, 9.52	1	1	1	1
215	43149351	SOCKET, 6.35	1			
216	43149352	NUT, FLARE, 15.88		1	1	1
217	43149353	SOCKET, 12.7	1			
218	43149354	SOCKET, 15.88		1	1	1
219	43149355	NUT, FLARE, 9.52		1	1	1
220	43149534	BAND, FIX, EVAPORATOR	2	2	2	2
221	4314J637	REFRIGERATION CYCLE ASSY	1			
222	4314J638	REFRIGERATION CYCLE ASSY		1	1	1
223	4314N205	COIL, PMV, PAM-MD12TF-301	1	1	1	1
224	4314N209	BODY, PMV, PAM-B40YGTF-2	1	1	1	1
225	43151328	SWITCH, FLOAT, FS-0218-103	1	1	1	1
226	43160691	LEAD, CONN	1	1	1	1
227	43170244	HOSE, DRAIN	1	1	1	1
228	43170290	HOSE, DRAIN	1	1	1	1
229	43172192	PAN ASSY, DRAIN	1			
230	43172193	PAN ASSY, DRAIN		1	1	1
231	43177028	PUMP, DRAIN, PMD-08D12TF-2	1	1	1	1
232	43179110	PLUG	1	1	1	1
233	43179163	BAND, HOSE	1	1	1	1
236	43F19904	HOLDER, SENSOR (TS)	2	2	2	2
237	43F47609	BONNET, 9.52		1	1	1
238	43F47685	NUT, FLARE, 6.35	1			
239	43F49697	BONNET, 6.35	1			
239	43166041	REMOTE CONTROLLER, WIRELESS, RBC-AXU31-E	1	1	1	1
240	43166042	REMOTE CONTROLLER, WIRED, RBC-AMSU51-EN	1	1	1	1
241	43166043	REMOTE CONTROLLER, WIRED, RBC-AMSU51-ES	1	1	1	1

MMU-UP0361WH-E(TR), UP0481WH-E(TR), UP0561WH-E(TR)

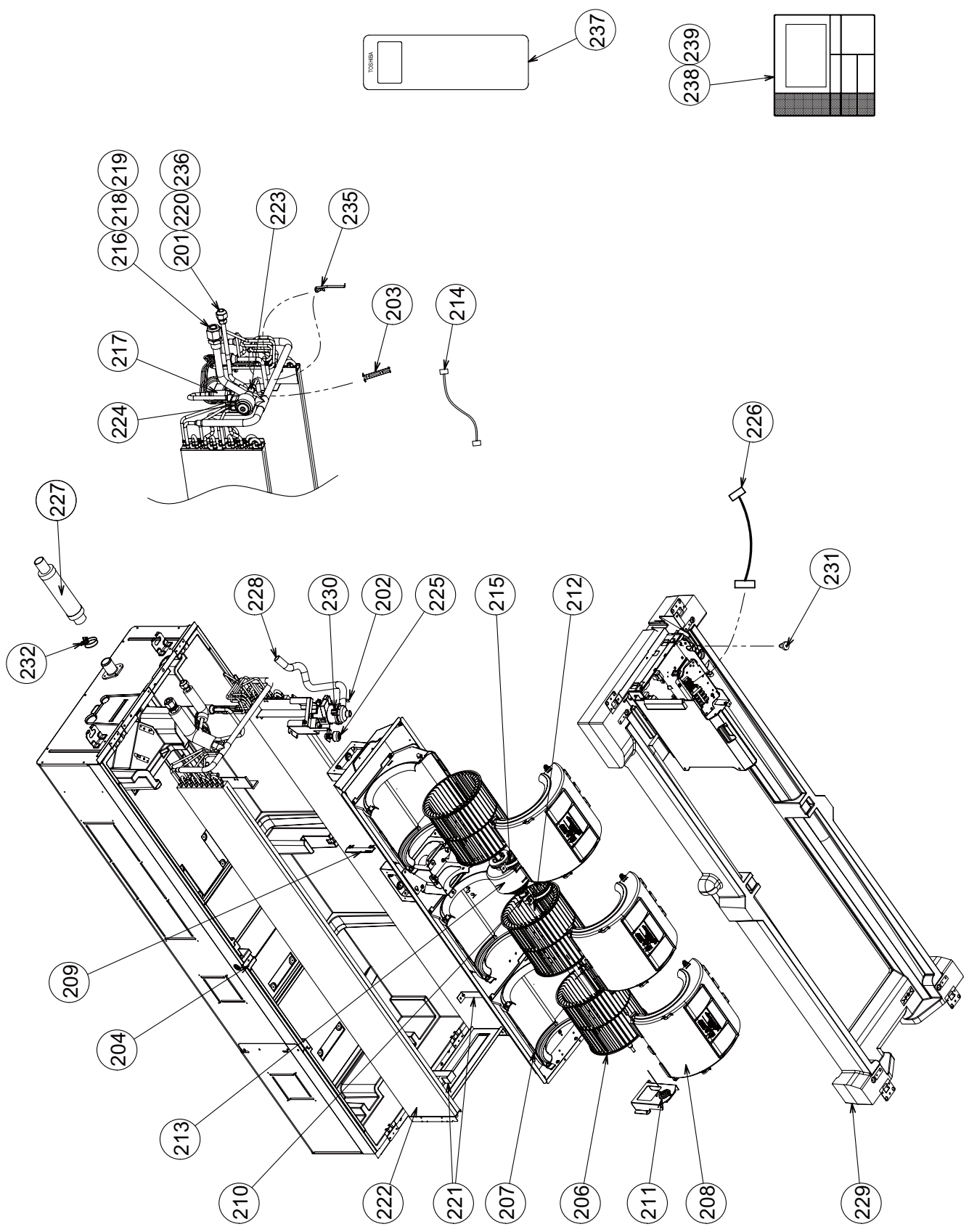



Location No.	Part No.	Description	MMU-UP		
			Q'ty/Set	0361WH-E (TR)	0481WH-E (TR)
201	43049776	SOCKET, 9.52	1	1	1
202	43079249	BAND, HOSE	1	1	1
203	43107215	HOLDER, SENSOR	1	1	1
204	43119479	NUT	2	2	2
206	43120239	FAN, MULTI BLADE	3	3	3
207	43122097	CASE, FAN	3	3	3
208	43122098	CASE, FAN	3	3	3
209	43122099	PLATE, WIND	6	6	6
210	43125162	COUPLING	1	1	1
211	43125199	BEARING ASSY, MOLD	1	1	1
212	43125203	SHAFT	1	1	1
213	4312C189	MOTOR, FAN, ICF-340WD139-3	1	1	1
214	43135021	CONNECTOR ASSY, PMV	1	1	1
215	43139152	BAND, MOTOR	2	2	2
216	43147194	BONNET, 15.88	1	1	1
217	43147664	STRAINER, 9.52	1	1	1
218	43149352	NUT, FLARE, 15.88	1	1	1
219	43149354	SOCKET,15.88	1	1	1
220	43149355	NUT, FLARE, 9.52	1	1	1
221	43149535	BAND, FIX, EVAPORATOR	2	2	2
222	4314J639	REFRIGERATION CYCLE ASSY	1	1	1
223	4314N203	BODY, PMV	1	1	1
224	4314N205	COIL, PMV	1	1	1
225	43151328	SWITCH, FLOAT, FS-0218-103	1	1	1
226	43160691	LEAD, CONN	1	1	1
227	43170244	HOSE, DRAIN	1	1	1
228	43170290	HOSE, DRAIN	1	1	1
229	43172194	PAN ASSY, DRAIN	1	1	1
230	43177028	PUMP, DRAIN, PMD-08D12TF-2	1	1	1
231	43179110	PLUG	1	1	1
232	43179163	BAND, HOSE	1	1	1
235	43F19904	HOLDER, SENSOR (TS)	2	2	2
236	43F47609	BONNET, 9.52	1	1	1
237	43166041	REMOTE CONTROLLER, WIRELESS, RBC-AXU31-E	1	1	1
238	43166042	REMOTE CONTROLLER, WIRED, RBC-AMSU51-EN	1	1	1
239	43166043	REMOTE CONTROLLER, WIRED, RBC-AMSU51-ES	1	1	1

## Electric Parts

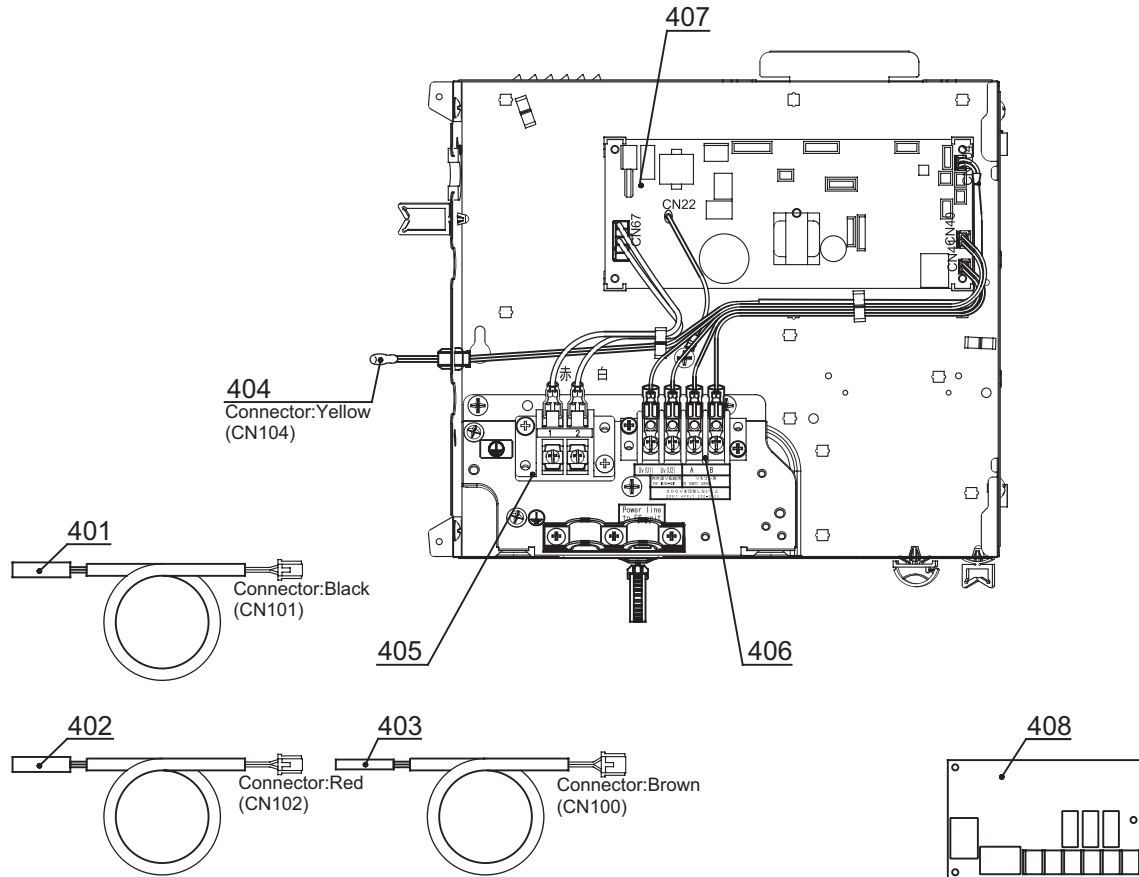

Location No.	Part No.	Description	Q'ty/Set
			MMU-UP0**1WH-E(TR)
401	43150422	SENSOR, TC	1
402	43150342	SENSOR (DOUBLE-COATED CABLES)	1
403	43150414	SENSOR, TEMP	1
404	43150421	SENSOR, TA	1
405	43160626	TERMINAL BLOCK, 2P, 20A	1
406	43160694	TERMINAL, 4P	1
407	4316V727	P.C. BOARD ASSY, MCC-1643	1
408	43459017	P.C. BOARD ASSY, TCB-PCUC*E	1

## ◆ Ceiling panel

RBC-UW283PG (W)-E, RBC-UW803PG (W)-E, RBC-UW1403PG (W)-E

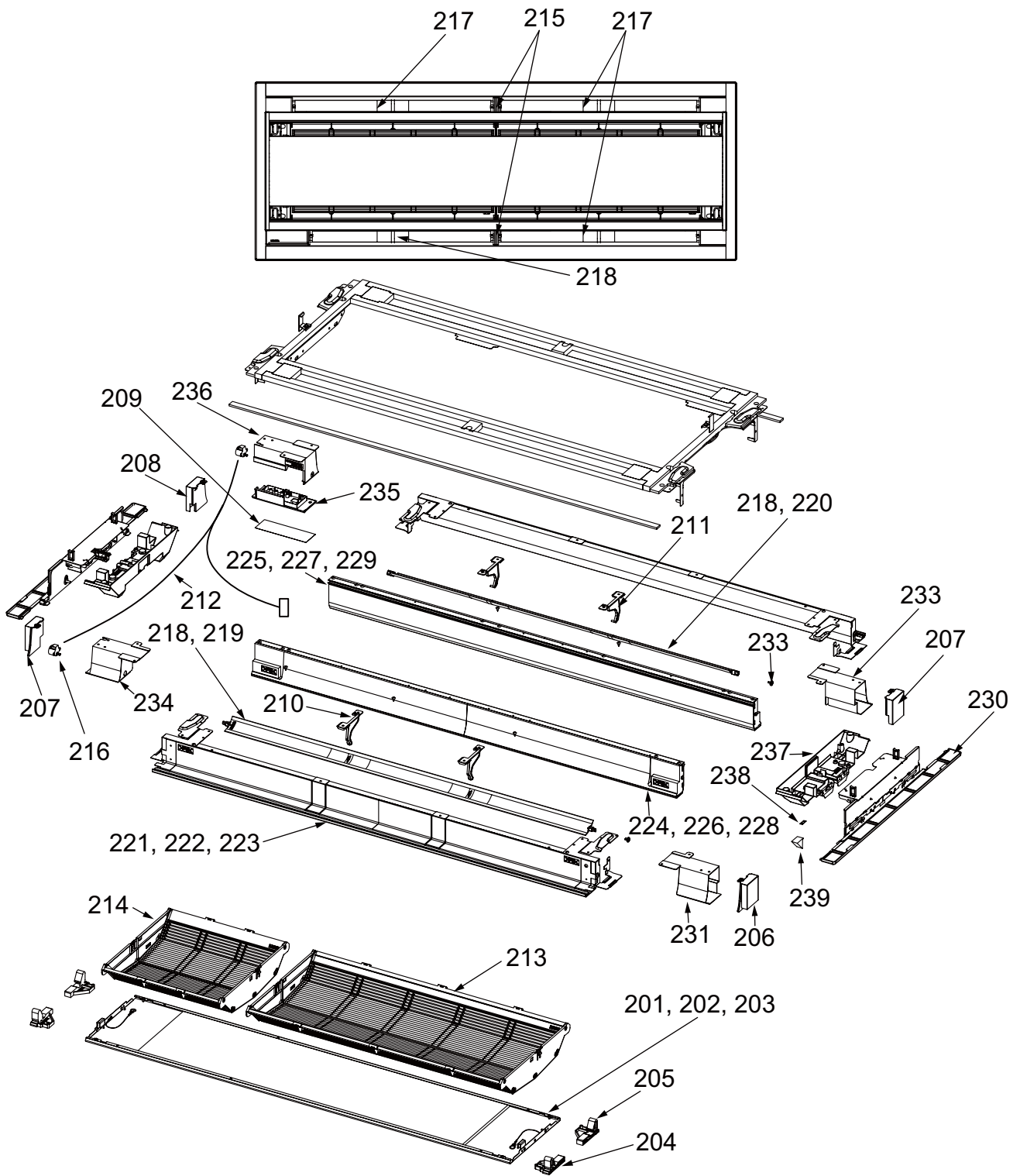

Location No.	Part No.	Description	Q'ty/Set RBC-UW		
			283PG (W)-E	803PG (W)-E	1403PG (W)-E
201	43409195	Panel, 941L	1		
202	43409196	Panel, 1306L		1	
203	43409197	Panel, 1726L			1
204	43407134	Hook, Inlet	2	2	2
205	43407135	Hook, Inlet	2	2	2
206	43403007	Cover, Spacer	1	1	1
207	43403008	Cover, Spacer	2	2	2
208	43403009	Cover, Spacer	1	1	1
209	43408036	Mark, TOSHIBA	1	1	1
210	43407136	Fix, Louver, Middle	1	2	2
211	43407137	Fix, Louver, Middle	1	2	2
212	43460115	Lead Ass'y, Motor	1	1	1
213	43409193	Filter Ass'y	1	1	2
214	43409194	Filter Ass'y		1	
215	43407138	Spacer, Louver, Middle			2
216	4302C063	Motor, Louver, MP24Z	2	2	2
217	43409189	Louver	1		3
218	43409190	Louver	1		1
219	43409191	Louver		1	
220	43409192	Louver		1	
221	43400069	Frame, Outlet	2		
222	43400071	Frame, Outlet		2	
223	43400073	Frame, Outlet			2
224	43400060	Frame, Inlet	1		
225	43400061	Frame, Inlet	1		
226	43400062	Frame, Inlet		1	
227	43400063	Frame, Inlet		1	
228	43400064	Frame, Inlet			1
229	43400065	Frame, Inlet			1
230	43400066	Cover, Body	2	2	2
231	43401030	Spacer	1	1	1
232	43401031	Spacer	1	1	1
233	43407140	Cap, Louver	2	2	2
234	43401033	Spacer, Motor	1	1	1
235	43401034	Base Ass'y, P.C. board	1	1	1
236	43401035	Cover, P.C. board	1	1	1
237	43100492	Cover Ass'y, Frame	2	2	2
238	43108025	Fix, Plate	4	4	4
239	43108024	Fix, Panel	4	4	4

# 12-3. 1-way Cassette Type (SH)

MMU-UP0151SH-E(TR), UP0181SH-E(TR), UP0241SH-E(TR)

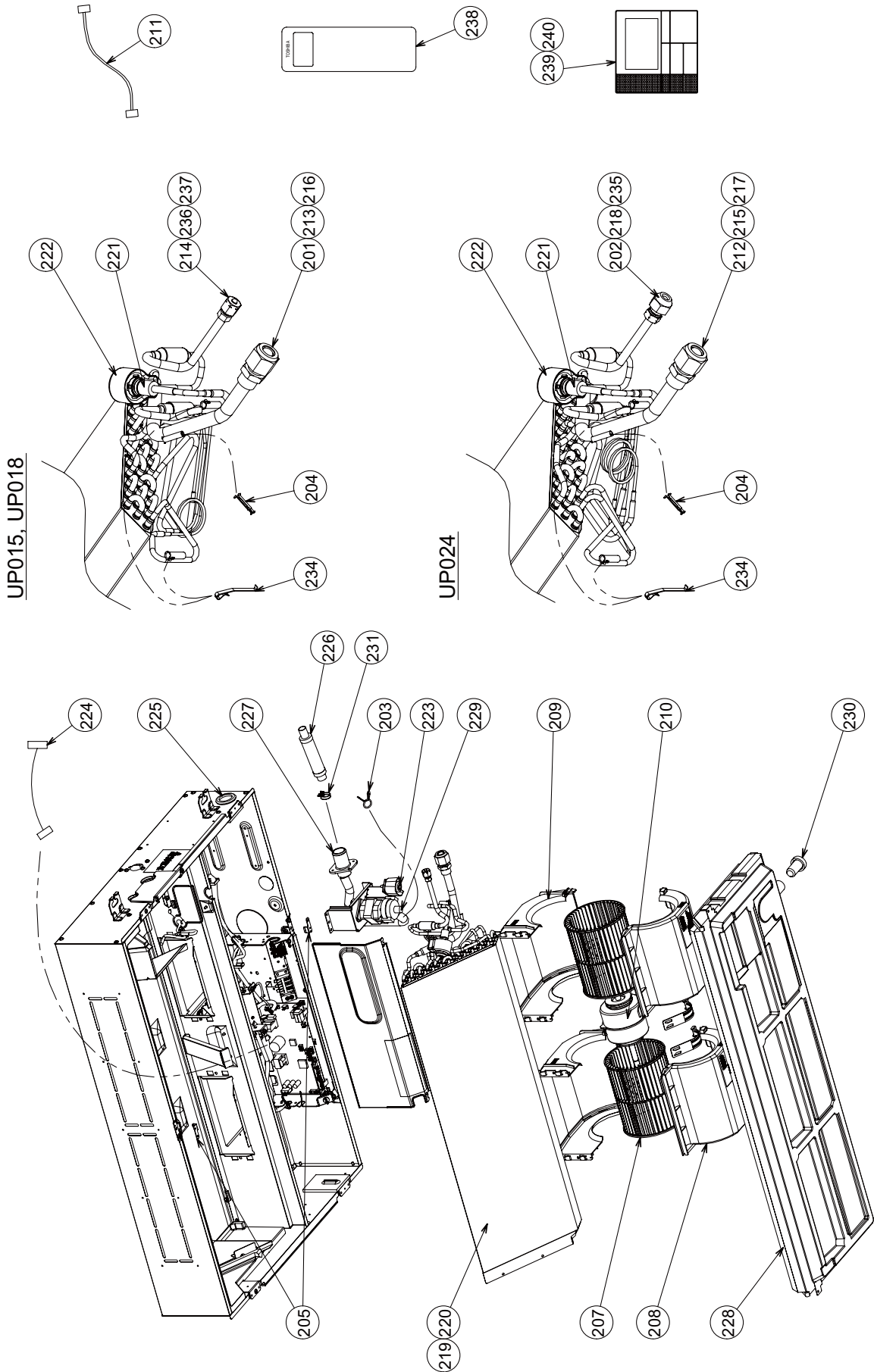

Location No.	Part No.	Description	MMU-UP		
			Q'ty/Set	0151SH-E (TR)	0181SH-E (TR)
201	43047688	NUT, FLARE, 12.7	1	1	
202	43049776	SOCKET, 9.52			1
203	43079249	BAND, HOSE	1	1	1
204	43107215	HOLDER, SENSOR	1	1	1
205	43119481	NUT, PLATE	2	2	2
207	43120257	FAN, MULTI BLADE	2	2	2
208	43122084	CASE, FAN, LOWER	2	2	2
209	43122085	CASE, FAN, UPPER	2	2	2
210	4312C183	MOTOR, FAN, ICF-340WD94-9	1	1	1
211	43135021	CONNECTOR ASSY, PMV	1	1	1
212	43147194	BONNET, 15.88			1
213	43147195	BONNET, 12.7	1	1	
214	43149351	SOCKET, 6.35	1	1	
215	43149352	NUT, FLARE, 15.88			1
216	43149353	SOCKET, 12.7	1	1	
217	43149354	SOCKET, 15.88			1
218	43149355	NUT, FLARE, 9.52			1
219	4314J641	REFRIGERATION CYCLE ASSY	1	1	
220	4314J642	REFRIGERATION CYCLE ASSY			1
221	4314N202	BODY, PMV, PAM-B40YGTF-1	1	1	1
222	4314N205	COIL, PMV, PAM-MD12TF-301	1	1	1
223	43151329	SWITCH, FLOAT, FS-0218-103	1	1	1
224	43160691	LEAD, CONN	1	1	1
225	43162051	BUSHING	1	1	1
226	43170244	HOSE, DRAIN	1	1	1
227	43170291	HOSE, DRAIN	1	1	1
228	43172195	PAN ASSY, DRAIN	1	1	1
229	43177027	PUMP, DRAIN	1	1	1
230	43179129	CAP DRAIN	1	1	1
231	43179163	BAND, HOSE	1	1	1
234	43F19904	HOLDER, SENSOR (TS)	2	2	2
235	43F47609	BONNET, 9.52			1
236	43F47685	NUT, FLARE, 6.35	1	1	
237	43F49697	BONNET, 6.35	1	1	
238	43166041	REMOTE CONTROLLER, WIRELESS, RBC-AXU31-E	1	1	1
239	43166042	REMOTE CONTROLLER, WIRED, RBC-AMU51-EN	1	1	1
240	43166043	REMOTE CONTROLLER, WIRED, RBC-AMU51-ES	1	1	1

# Electric Parts

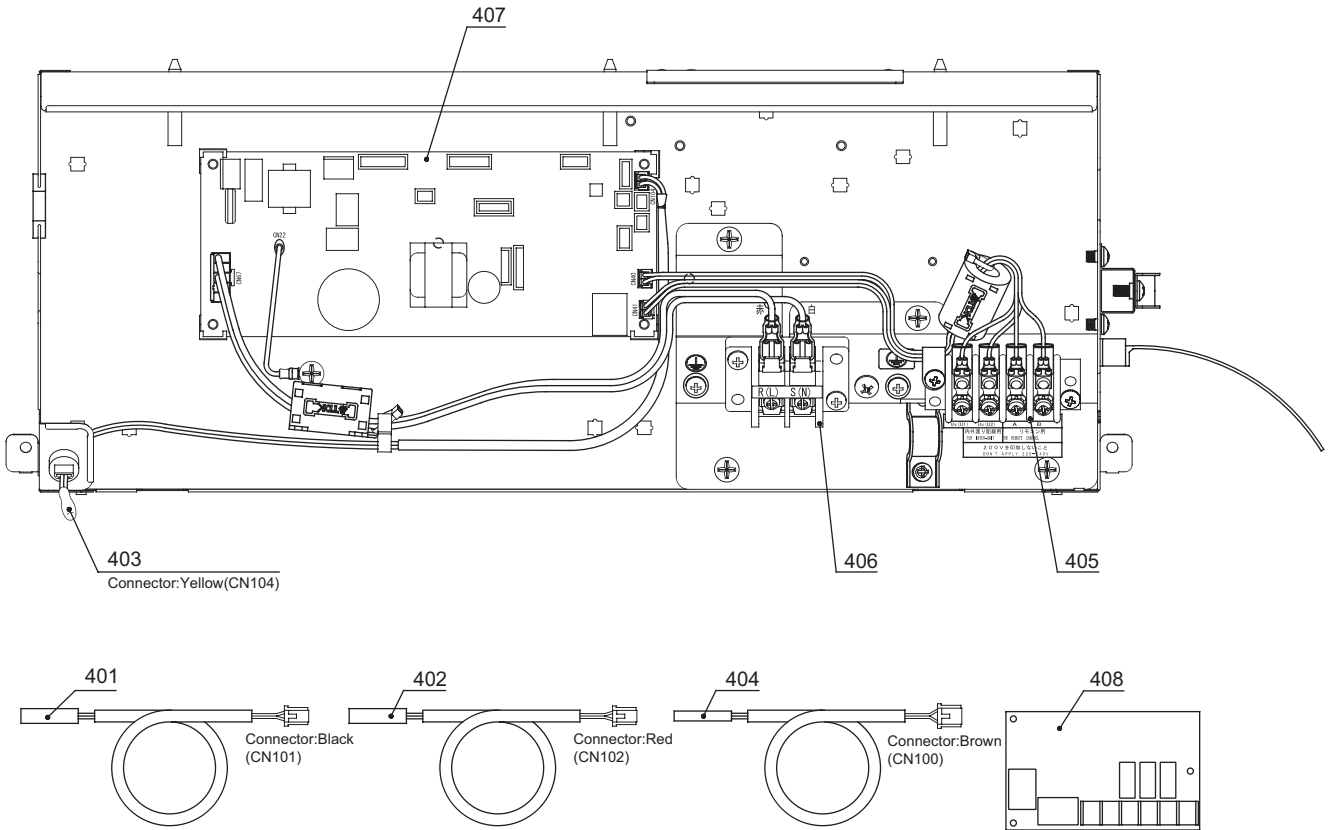

Location No.	Part No.	Description	Q'ty/Set
			MMU-UP0**1SH-E(TR)
401	43150361	SENSOR, TC	1
402	43150362	SENSOR, TC	1
403	43150421	SENSOR, TA	1
404	43150414	SENSOR, TEMP	1
405	43160694	TERMINAL, 4P	1
406	43160626	TERMINAL BLOCK, 2P	1
407	4316V727	P.C. BOARD ASSY, MCC-1643	1
408	43459017	P.C. BOARD ASSY, TCB-PCUC*E	1



## ◆ Ceiling panel

RBC-US21PGE

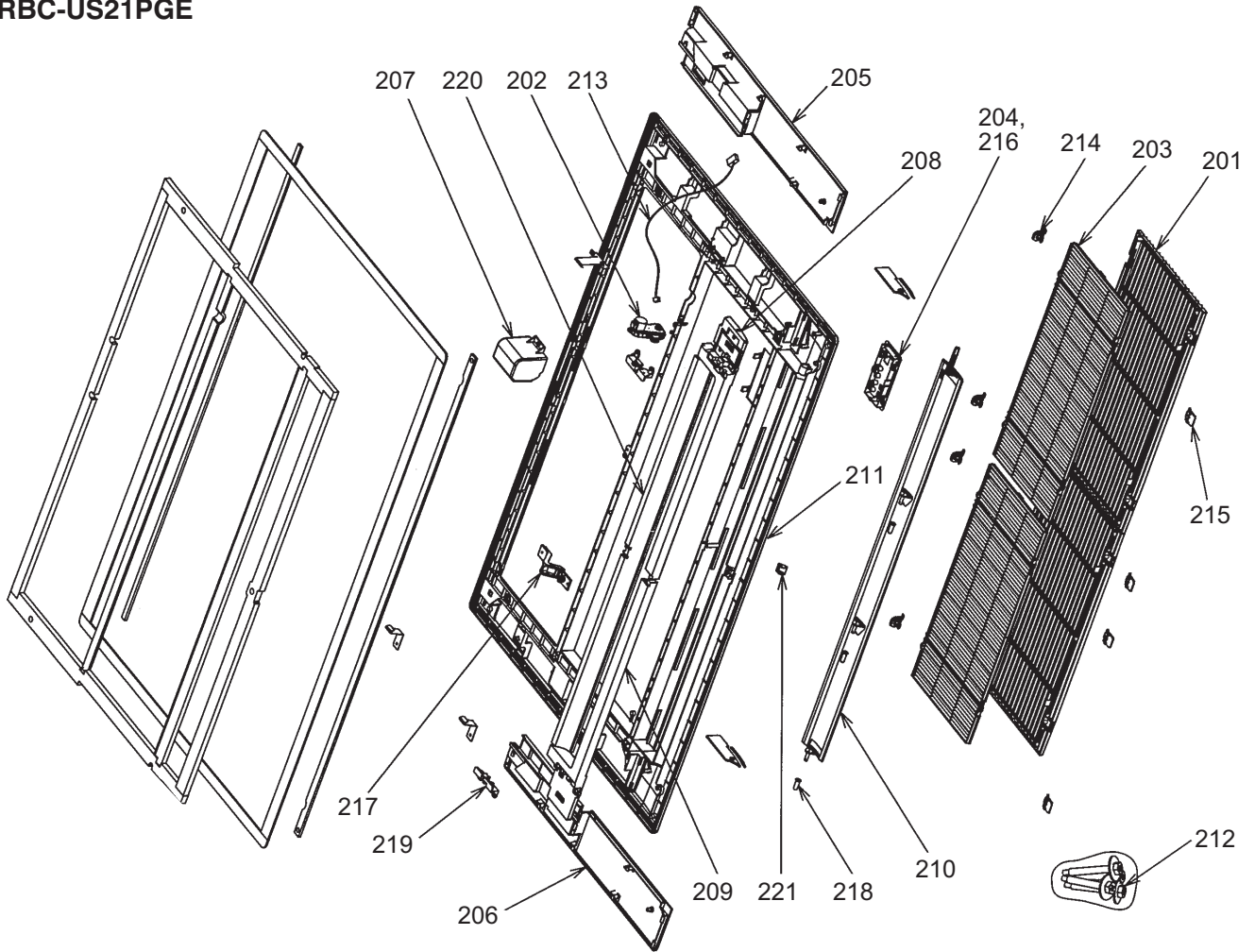

Location No.	Part No.	Description	Q'ty/Set
			RBC-US21PGE
201	43109408	GRILLE, INLET	2
202	43121719	DRIVER A'SSY, HORIZONTAL LOUVER	1
203	43180315	AIR FILTER	2
204	43108014	BASE, RECEIVER	1
205	43401025	COVER ASSY	1
206	43401026	COVER ASSY	1
207	43419011	COVER, MOTOR	1
208	43419012	PANEL, AIR OUTLET	1
209	43419013	PANEL, OUTLET	1
210	43409188	LOUVER	1
211	43401027	PANEL ASSY	1
212	43497012	SCREW	4
213	43460112	LEAD ASSY, LOUVER, MOTOR	1
214	43107254	HINGE, GRILLE INLET	4
215	43107255	HOOK, GRILLE INLET	4
216	43408033	MARK, TOSHIBA	1
217	43419015	SUPPORTER, OUTLET	1
218	43419016	SUPPORTER, SHAFT	3
219	43419017	SUPPORTER, MOTOR	2
220	43419018	PANEL, OUTLET	1
221	43419019	SCREW, CAP ASSY	1

# 12-4. Floor Standing Cabinet Type

MML- UP0071H-E(TR), UP0091H-E(TR), UP0121H-E(TR), UP0151H-E(TR), UP0181H-E(TR), UP0241H-E(TR)

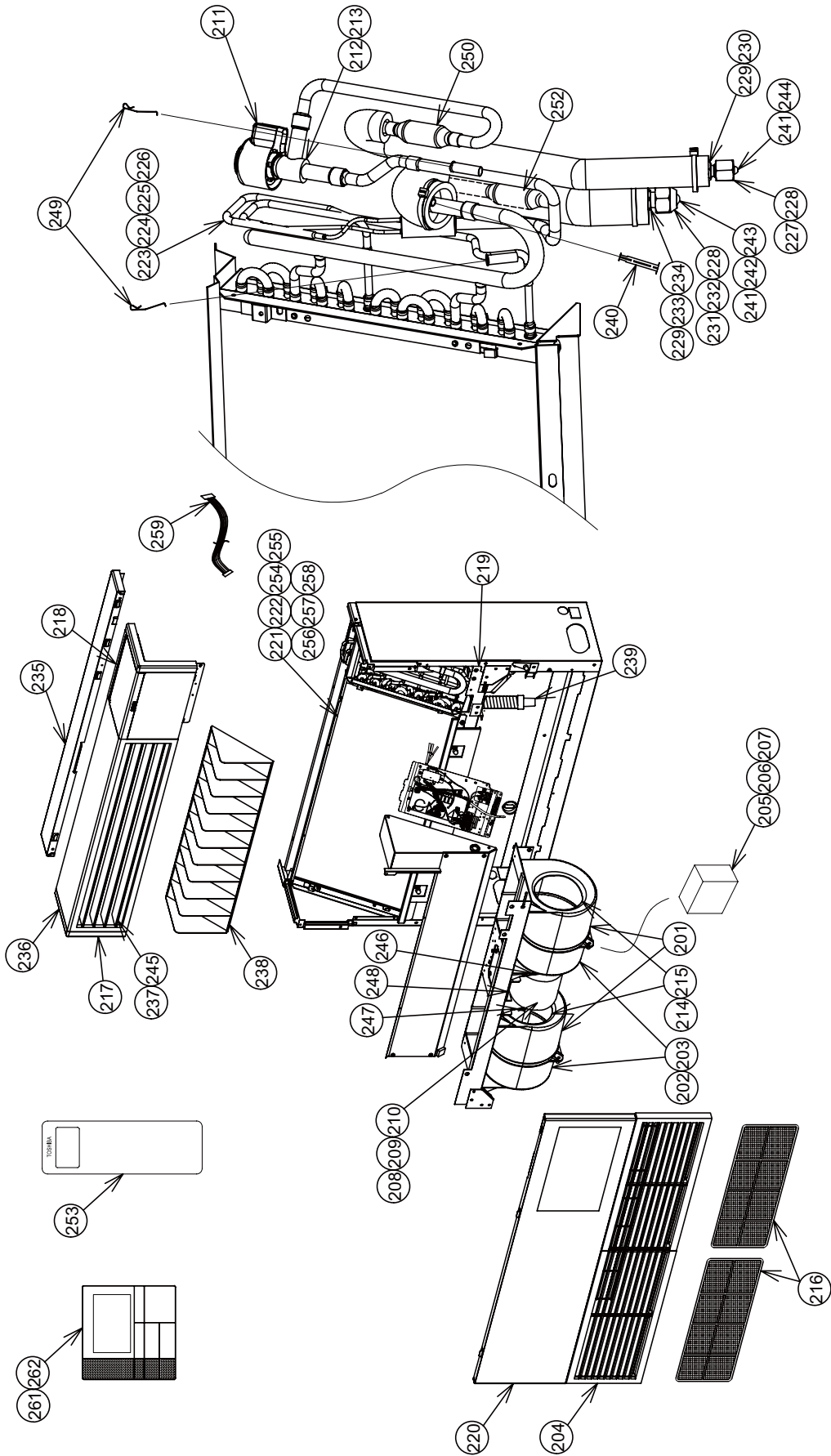

Location No.	Part No.	Description	Q'ty/Set			MML-UP		
			0071H -E (TR)	0091H -E (TR)	0121H- E (TR)	0151H -E (TR)	0181H -E (TR)	0241H -E (TR)
201	43723020	CASE, FAN, LEFT	2	2	2	2	2	2
202	43723019	CASE, FAN, RIGHT	2	2	2	2		
203	43126119	CASE, FAN, RIGHT					2	2
204	43109394	GRILL,INLET,WHITE	2	2	2	2	2	2
205	43155190	CAPACITOR, 400V 1.8MF			1	1		
206	43155171	CAPACITOR, 450V 2.0MF					1	1
207	43155195	CAPACITOR, 450V 1.2MF	1	1				
208	4312C007	MOTOR, FAN, AF-200-45-4FR			1	1		
209	4312C008	MOTOR, FAN, AF-200-70-4KR					1	1
210	4312C026	MOTOR, FAN, AF-200-19-4FR	1	1				
211	4314N205	COIL, PMV, PAM-MD12TF-301	1	1	1	1	1	1
212	4314N210	BODY, PMV, PAM-B25YGTF-1	1	1				
213	4314N209	BODY, PMV, PAM-B40YGTF-2			1	1	1	1
214	43120228	FAN, MULTI BLADE	2	2	2	2		
215	43120232	FAN, MULTI BLADE					2	2
216	43180280	AIR FILTER	2	2	2	2	2	2
217	43101346	FRAME, WHITE	1	1	1	1	1	1
218	43101347	COVER, CONTROL PANEL, WHITE	1	1	1	1	1	1
219	43172101	PAN, DRAIN	1	1	1	1	1	1
220	43100366	PANEL, FRONT	1	1	1	1	1	1
221	4314J419	EVAPORATOR ASSY	1	1	1	1		
222	4314J420	EVAPORATOR ASSY					1	1
223	4314Q155	DISTRIBUTOR ASSY	1	1				
224	4314Q156	DISTRIBUTOR ASSY			1	1		
225	4314Q157	DISTRIBUTOR ASSY						1
226	4314Q160	DISTRIBUTOR ASSY					1	
227	43F47685	NUT, FLARE, 1/4 IN	1	1	1	1	1	
228	43149355	NUT, FLARE, 9.52	1	1	1			1
229	43049776	SOCKET, 9.52	1	1	1			1
230	43149351	SOCKET, 6.35	1	1	1	1	1	
231	43047688	NUT, FLARE, 12.7				1	1	
232	43149352	NUT, FLARE, 15.88						1
233	43149353	SOCKET, 12.7				1	1	
234	43149354	SOCKET, 15.88						1
235	43100374	CABINET, UPPER, WHITE	1	1	1	1	1	1
236	43100228	OUTLET, WHITE	1	1	1	1	1	1
237	43109459	GRILLE, WHITE	3	3	3	3	3	3
238	43109240	GRILLE	1	1	1	1	1	1
239	43170201	HOSE, DRA1N	1	1	1	1	1	1
240	43107215	HOLDER, SENSOR	1	1	1	1	1	1
241	43F47609	BONNET,9.52	1	1	1			1
242	43147195	BONNET, 12.7				1	1	
243	43194029	BONNET, 15.88						1
244	43F49697	BONNET, 6.35	1	1	1	1	1	
245	43196087	BUSHING, GRILLE	6	6	6	6	6	6
246	43139154	BAND, MOTOR, LEFT	2	2	2	2	2	2
247	43139155	BAND, MOTOR, RIGHT	2	2	2	2	2	2
248	43122104	BASE, MOTOR	1	1	1	1	1	1
249	43F19904	HOLDER, SENSOR (TS)	2	2	2	2	2	2
250	43147664	STRAINER, ID9.52	1	1	1	1	1	1
252	43147649	STRAINER	1	1	1			
253	43166041	REMOTE CONTROLLER, WIRELESS,RBC-AXU31-E	1	1	1	1	1	1
254	4314J619	REFRIGERATION CYCLE ASSY	1	1				
255	4314J643	REFRIGERATION CYCLE ASSY			1			
256	4314J620	REFRIGERATION CYCLE ASSY				1		
257	4314J640	REFRIGERATION CYCLE ASSY					1	
258	4314J621	REFRIGERATION CYCLE ASSY						1
259	43135024	CONNECTOR ASSY, PMV	1	1	1	1	1	1
261	43166042	REMOTE CONTROLLER, WIRED, RBC-AMSU51-EN	1	1	1	1	1	1
262	43166043	REMOTE CONTROLLER, WIRED, RBC-AMSU51-ES	1	1	1	1	1	1

# Electric Parts

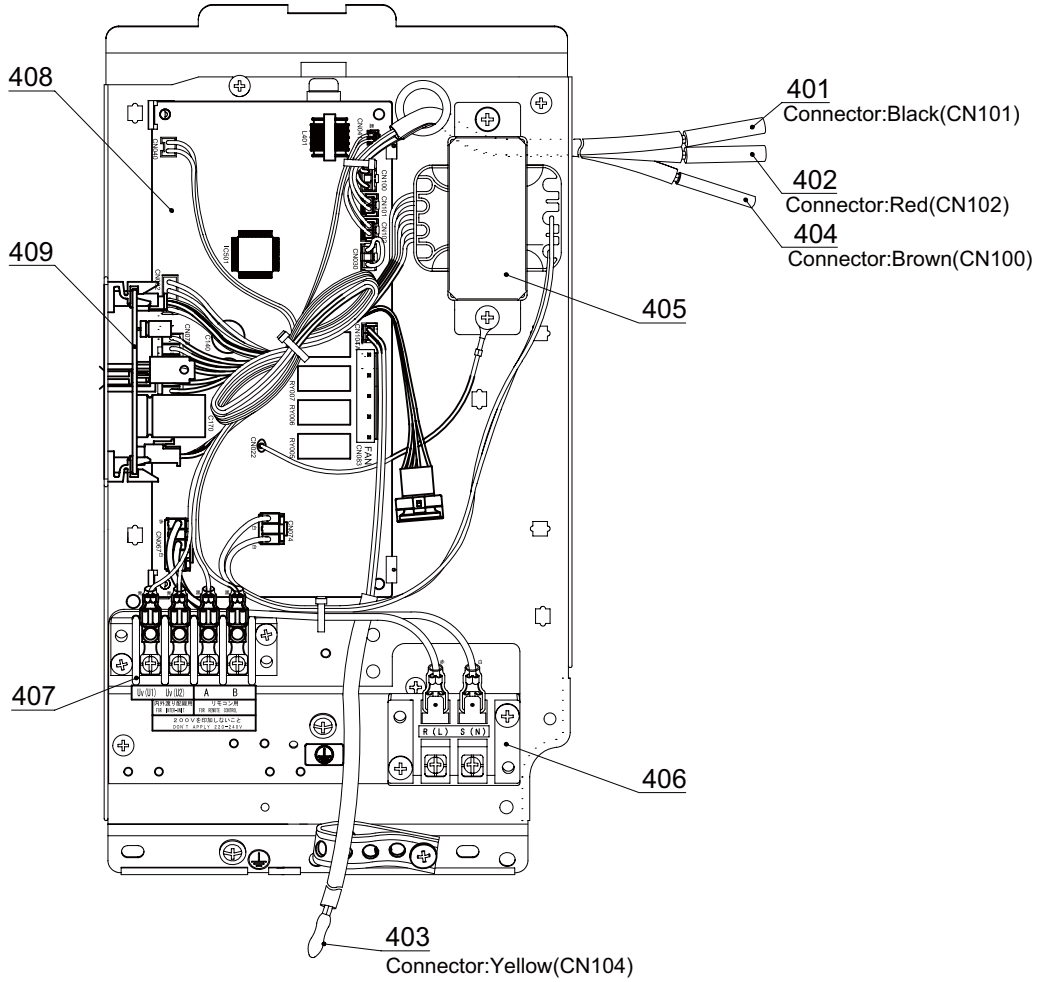

Location No.	Part No.	Description	Q'ty/Set
			MML-UP0**1H-E(TR)
401	43150424	SENSOR, TC	1
402	43150425	SENSOR, TC	1
403	4115A123	SENSOR,TA	1
404	43150414	SENSOR, TEMP	1
405	43158204	TRANSFORMER, TT-13	1
406	43160626	TERMINAL BLOCK, 2P, 20A	1
407	43160694	TERMINAL, 4P	1
408	4316V734	P.C. BOARD ASSY, MCC-1744	1
409	4316V345	P.C. BOARD ASSY, MCC-1520	1

# 12-5. Floor Standing Concealed Type

MML-UP0071BH-E(TR), UP0091BH-E(TR), UP0121BH-E(TR), UP0151BH-E(TR), UP0181BH-E(TR), UP0241BH-E(TR)

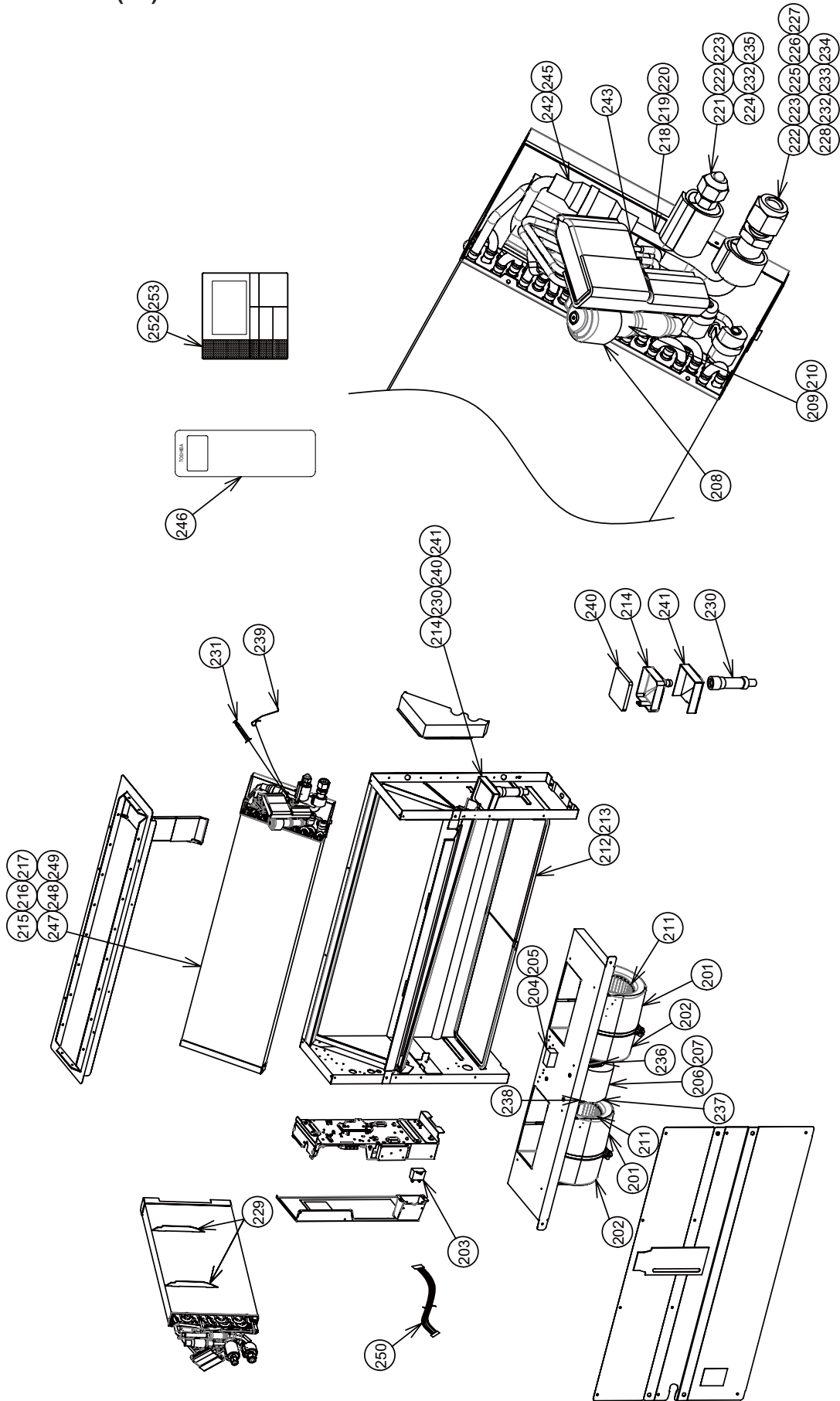

Location No.	Part No.	Description	Q'ty/Set			MML-UP		
			0071BH -E (TR)	0091BH -E (TR)	0121BH -E (TR)	0151BH -E (TR)	0181BH -E (TR)	0241BH -E (TR)
201	43723020	CASE, FAN, LEFT	1	1	1	2	2	2
202	43126119	CASE, FAN, RIGHT	1	1	1	2	2	2
203	43155179	CAPACITOR, 1.5MFD,450V	1	1	1			
204	43155171	CAPACITOR, 450V 2.0MF						1
205	43155191	CAPACITOR, 450V 1MF				1	1	
206	4312C008	MOTOR, FAN, AF-200-70-4KR				1	1	1
207	4312C024	MOTOR, FAN, AF-200-19-4GR	1	1	1			
208	4314N205	COIL, PMV, PAM-MD12TF-301	1	1	1	1	1	1
209	4314N210	BODY, PMV, PAM-B25YGTF-1	1	1	1			
210	4314N209	BODY, PMV, PAM-B40YGTF-2				1	1	1
211	43120232	FAN, MULTI BLADE	1	1	1	2	2	2
212	43180294	FILTER	1	1	1			
213	43180295	FILTER				1	1	1
214	43170206	CATCH, DRAIN	1	1	1	1	1	1
215	4314J429	EVAPORATOR ASSY	1	1	1			
216	4314J430	EVAPORATOR ASSY				1	1	
217	4314J431	EVAPORATOR ASSY						1
218	4314Q152	DISTRIBUTOR ASSY	1	1	1			
219	4314Q153	DISTRIBUTOR ASSY				1	1	
220	4314Q154	DISTRIBUTOR ASSY						1
221	43F47685	NUT, FLARE, 9.52	1	1	1	1	1	
222	43149355	NUT, FLARE, 9.52	1	1	1			1
223	43049776	SOCKET, 9.52	1	1	1			1
224	43149351	SOCKET, 6.35	1	1	1	1	1	
225	43047688	NUT, FLARE, 12.7				1	1	
226	43149352	NUT, FLARE, 15.88						1
227	43149353	SOCKET,12.7				1	1	
228	43149354	SOCKET,15.88						1
229	43122046	PLATE-WIND	2	2	2			
230	43170197	HOSE ASSY	1	1	1	1	1	1
231	43107215	HOLDER, SENSOR	1	1	1	1	1	1
232	43F47609	BONNET,9.52	1	1	1			1
233	43147195	BONNET, 1/2 IN				1	1	
234	43194029	BONNET,15.88						1
235	43F49697	BONNET, 6.35	1	1	1	1	1	
236	43139154	BAND, MOTOR, LEFT	2	2	2	2	2	2
237	43139155	BAND, MOTOR, RIGHT	2	2	2	2	2	2
238	43122104	BASE, MOTOR	1	1	1	1	1	1
239	43F19904	HOLDER, SENSOR (TS)	2	2	2	2	2	2
240	43170207	STRAINER	1	1	1	1	1	1
241	43111311	HINS	1	1	1	1	1	1
242	43147664	STRAINER, ID 9.52				1	1	1
243	43147724	STRAINER	1	1	1			
245	4314Q043	STRAINER	1	1	1			
246	43166041	REMOTE CONTROLLER, WIRELESS, RBC-AXU31-E	1	1	1	1	1	1
247	4314J616	REFRIGERATION CYCLE ASSY	1	1	1			
248	4314J617	REFRIGERATION CYCLE ASSY				1	1	
249	4314J618	REFRIGERATION CYCLE ASSY						1
250	43160699	CONNECTOR ASSY, PMV	1	1	1	1	1	1
252	43166042	REMOTE CONTROLLER, WIRED, RBC-AMSU51-EN	1	1	1	1	1	1
253	43166043	REMOTE CONTROLLER, WIRED, RBC-AMSU51-ES	1	1	1	1	1	1

# Electric Parts

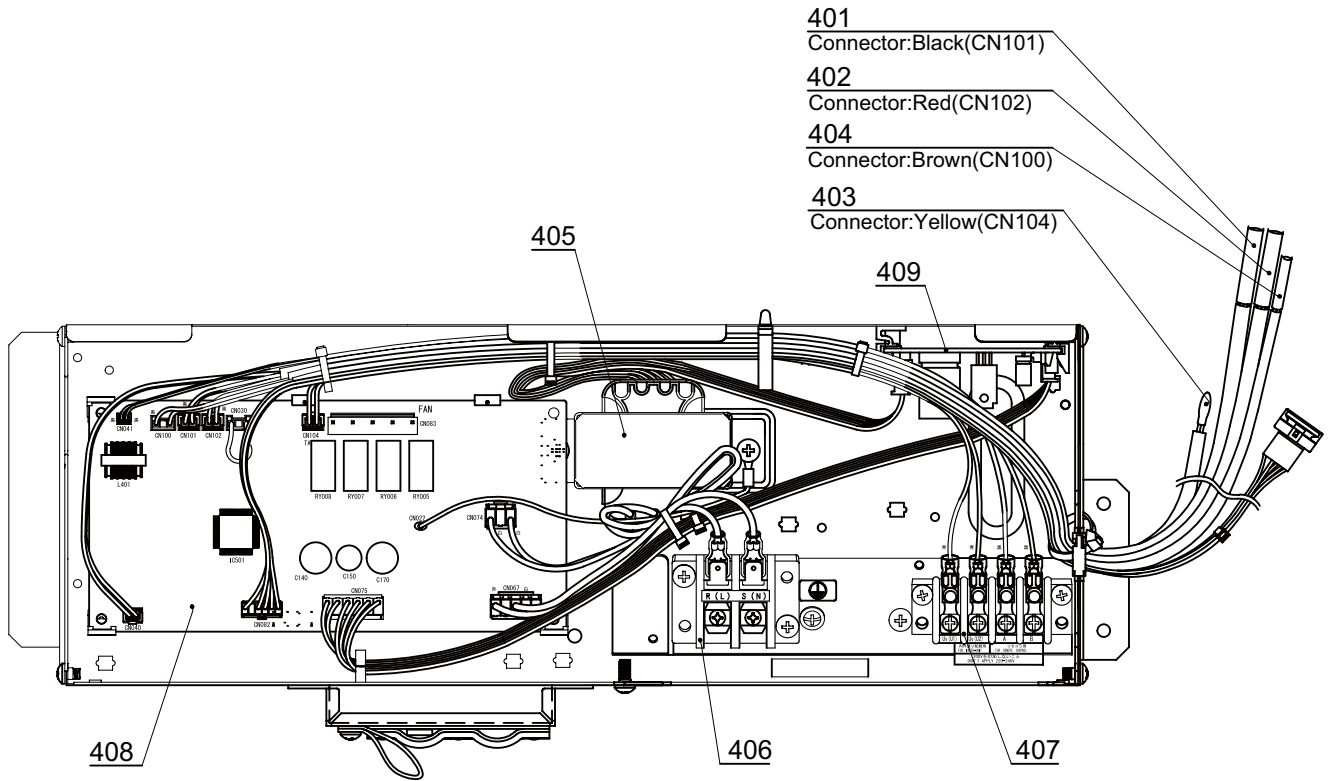

- 401  
Connector:Black(CN101)
- 402  
Connector:Red(CN102)
- 404  
Connector:Brown(CN100)
- 403  
Connector:Yellow(CN104)

Location No.	Part No.	Description	Q'ty/Set
			MML-UP0**1BH-E(TR)
401	43150426	SENSOR, TC	1
402	43150427	SENSOR, TC	1
403	4115A123	SENSOR,TA	1
404	43150415	SENSOR, TEMP	1
405	43158204	TRANSFORMER, TT-13	1
406	43160626	TERMINAL BLOCK, 2P, 20A	1
407	43160694	TERMINAL, 4P	1
408	4316V734	P.C. BOARD ASSY, MCC-1744	1
409	4316V345	P.C. BOARD ASSY, MCC-1520	1



# 12-6. Floor Standing Type

MMF-UP0151H-E(TR), UP0181H-E(TR), UP0241H-E(TR), UP0271H-E(TR)

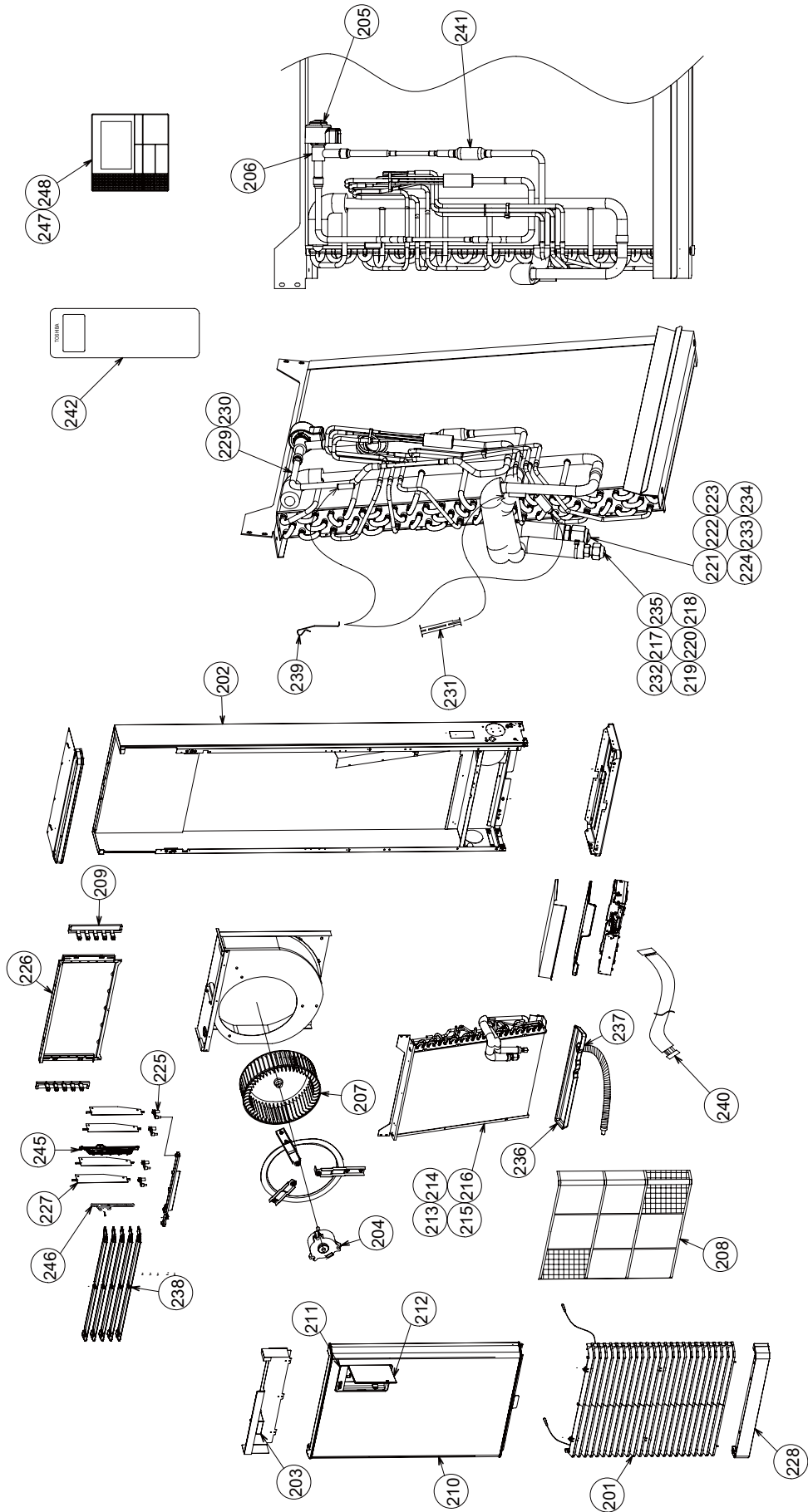

Location No.	Part No.	Description	Q'ty/Set		MMF-UP	
			0151H -E (TR)	0181H -E (TR)	0241H -E (TR)	0271H -E (TR)
201	43109392	GRILLE, INLET	2	2	2	2
202	43100388	CASE ASSY	1	1	1	1
203	43F2C076	MOTOR, LOUVER	1	1	1	1
204	4312C133	MOTOR, FAN, ICF-340D62-1	1	1	1	1
205	4314N205	COIL, PMV, PAM-MD12TF-301	1	1	1	1
206	4314N209	BODY, PMV, PAM-B40YGTF-2	1	1	1	1
207	43120271	FAN, MULTI BLADE	1	1	1	1
208	43180238	AIR FILTER	1	1	1	1
209	43109455	CLAMP, LOUVER	2	2	2	2
210	4310A186	CABINET ASSY, UPPER	1	1	1	1
211	43101357	PANEL, REMOTE CONTROLER	1	1	1	1
212	43101345	COVER, REMOTE CONTROLER	1	1	1	1
213	4314J410	EVAPORATOR ASSY	1	1		
214	4314J411	EVAPORATOR ASSY			1	1
215	4314J622	REFRIGERATION CYCLE ASSY	1	1		
216	4314J623	REFRIGERATION CYCLE ASSY			1	1
217	43F47685	NUT, FLARE, 9.52	1	1		
218	43149355	NUT, FLARE, 9.52			1	1
219	43049776	SOCKET, 9.52			1	1
220	43149351	SOCKET, 6.35	1	1		
221	43047688	NUT, FLARE, 12.7	1	1		
222	43149352	NUT, FLARE, 15.88			1	1
223	43149353	SOCKET, 12.7	1	1		
224	43149354	SOCKET, 15.88			1	1
225	43139093	CONNECTION ROD	5	5	5	5
226	3759V024	GRILLE ASSY	1	1	1	1
227	43109207	GRILLE, OUTLET, VERTICAL	4	4	4	4
228	43100373	CABINET, LOWER	1	1	1	1
229	4314Q161	DISTRIBUTOR ASSY	1	1		
230	4314Q162	DISTRIBUTOR ASSY			1	1
231	43107215	HOLDER, SENSOR	1	1	1	1
232	43F47609	BONNET, 9.52			1	1
233	43147195	BONNET, 12.7	1	1		
234	43194029	BONNET, 15.88			1	1
235	43F49697	BONNET, 6.35	1	1		
236	43172090	PAN, DRAIN	1	1	1	1
237	43197136	WASHER	1	1	1	1
238	43122193	LOUVER, HORIZONTAL	5	5	5	5
239	43F19904	HOLDER, SENSOR (TS)	2	2	2	2
240	43160700	CONNECTOR ASSY, PMV	1	1	1	1
241	43147664	STRAINER, ID 9.52	1	1	1	1
242	43166041	REMOTE CONTROLLER, WIRELESS, RBC-AXU31-E	1	1	1	1
245	43122194	CLAMP, LOUVER, CENTER	1	1	1	1
246	43122195	JOINT, LOUVER	1	1	1	1
247	43166042	REMOTE CONTROLLER, WIRED, RBC-AMSU51-EN	1	1	1	1
248	43166043	REMOTE CONTROLLER, WIRED, RBC-AMSU51-ES	1	1	1	1

MMF-UP0361H-E(TR), UP0481H-E(TR), UP0561H-E(TR)

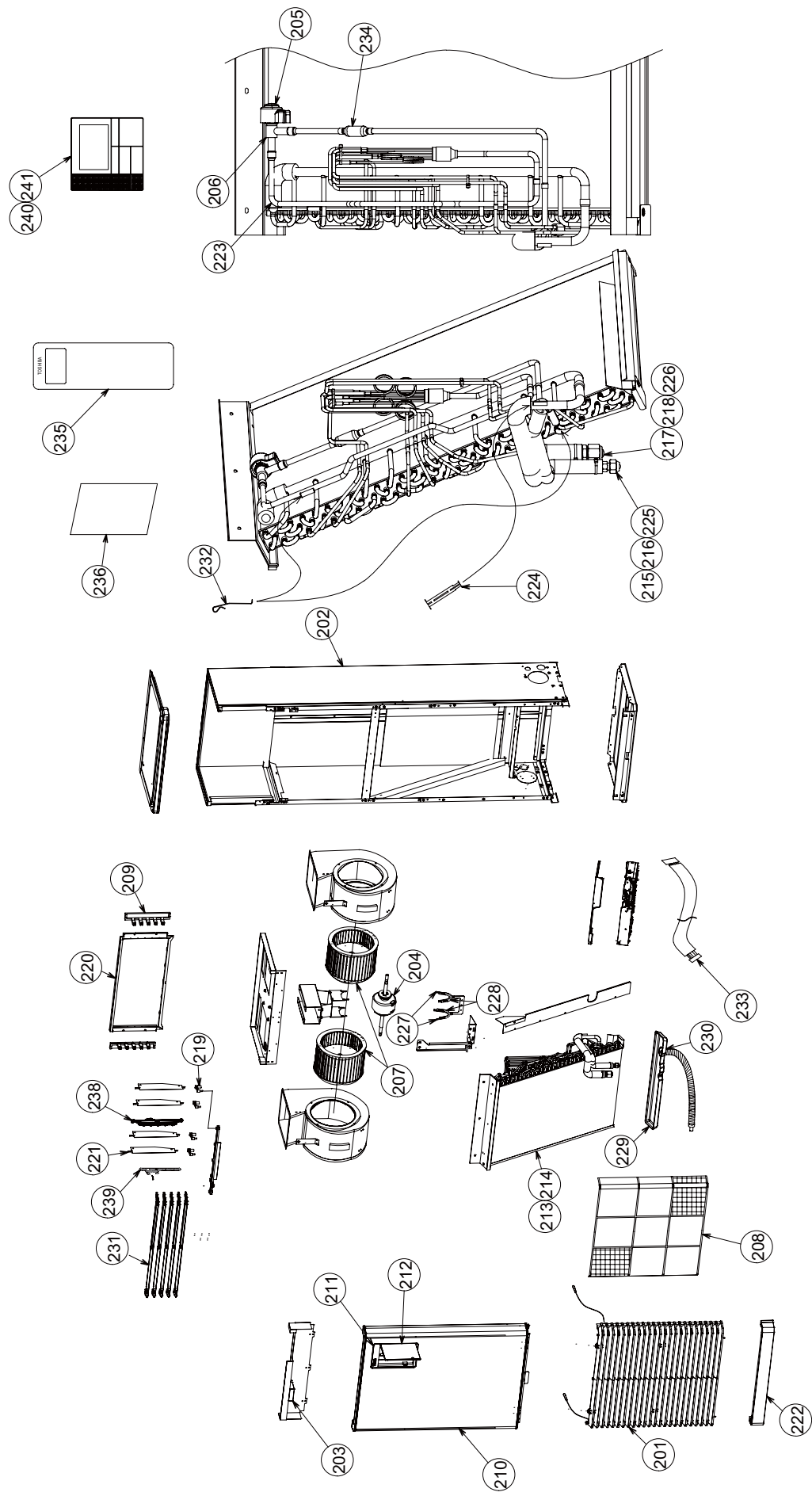

Location No.	Part No.	Description	MMF-UP		
			Q'ty/Set 0361H -E (TR)	0481H -E (TR)	0561H -E (TR)
201	43109392	GRILLE, INLET	2	2	2
202	43102650	CASE ASSY	1	1	1
203	43F2C076	MOTOR, LOUVER	1	1	1
204	4312C134	MOTOR, FAN, ICF-340WD109-1	1	1	1
205	4314N205	COIL, PMV, PAM-MD12TF-301	1	1	1
206	4314N203	BODY, PMV, PAM-B60YGTF-1	1	1	1
207	43120272	FAN, MULTI BLADE	2	2	2
208	43180238	AIR FILTER	1	1	1
209	43109455	CLAMP, LOUVER	2	2	2
210	4310A219	CABINET ASSY, UPPER	1	1	1
211	43101357	PANEL, REMOTE CONTROLER	1	1	1
212	43101345	COVER, REMOTE CONTROLER	1	1	1
213	4314J412	EVAPORATOR ASSY	1	1	1
214	4314J624	REFRIGERATION CYCLE ASSY	1	1	1
215	43149355	NUT, FLARE, 9.52	1	1	1
216	43049776	SOCKET,9.52	1	1	1
217	43149352	NUT, FLARE, 15.88	1	1	1
218	43149354	SOCKET, 15.88	1	1	1
219	43139093	CONNECTION ROD	5	5	5
220	3759V024	GRILLE ASSY	1	1	1
221	43109207	GRILLE, OUTLET, VERTICAL	4	4	4
222	43100373	CABINET, LOWER	1	1	1
223	4314Q165	DISTRIBUTOR ASSY	1	1	1
224	43107215	HOLDER, SENSOR	1	1	1
225	43F47609	BONNET, 9.52	1	1	1
226	43194029	BONNET, 15.88	1	1	1
227	43139154	BAND, MOTOR, LEFT	2	2	2
228	43139155	BAND, MOTOR, RIGHT	2	2	2
229	43172090	PAN, DRAIN	1	1	1
230	43197136	WASHER	1	1	1
231	43122193	LOUVER, HORIZONTAL	5	5	5
232	43F19904	HOLDER, SENSOR (TS)	2	2	2
233	43160700	CONNECTOR ASSY, PMV	1	1	1
234	43147664	STRAINER, ID 9.52	1	1	1
235	43166041	REMOTE CONTROLLER, WIRELESS, RBC-AXU31-E	1	1	1
238	43122194	CLAMP, LOUVER, CENTER	1	1	1
239	43122195	JOINT, LOUVER	1	1	1
240	43166042	REMOTE CONTROLLER, WIRED, RBC-AMSU51-EN	1	1	1
241	43166043	REMOTE CONTROLLER, WIRED, RBC-AMSU51-ES	1	1	1

# Electric Parts

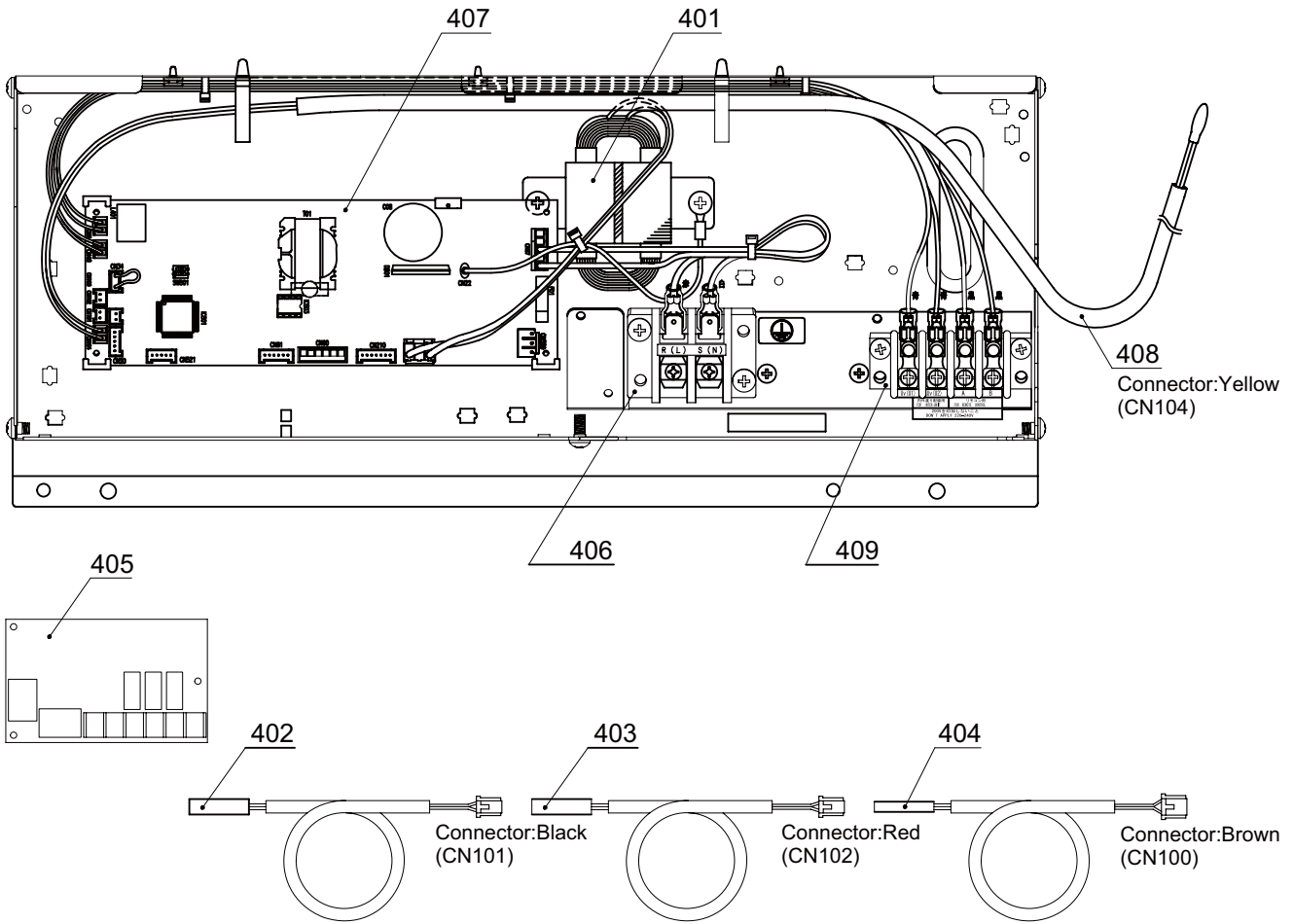

Location No.	Part No.	Description	Q'ty/Set
			MMF-UP0**1H-E(TR)
401	44258091	REACTOR, CH-49-Z-T	1
402	43150412	SENSOR, TC	1
403	43150362	SENSOR, TC	1
404	43150414	SENSOR, TEMP	1
405	43459017	PC BOARD ASSY, TCB-PCUC*E	1
406	43160626	TERMINAL BLOCK, 2P, 20A	1
407	4316V728	PC BOARD ASSY, MCC-1643	1
408	43150418	SENSOR, TA	1
409	43160694	TERMINAL, 4P	1

## ◆ Wireless remote controller kit

RBC-AXU41U-E(TR)

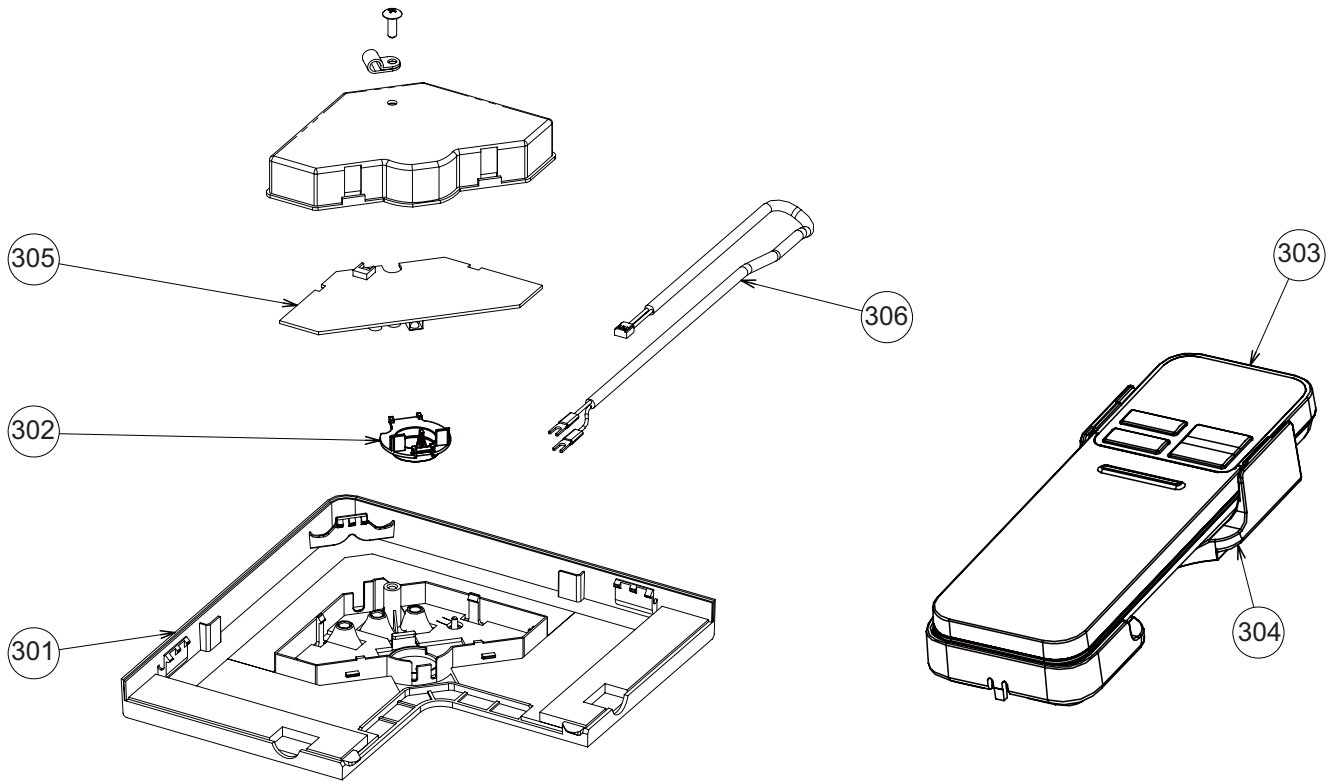

Location No.	Part No.	Description	Q'ty/Set
301	43108039	COVER, INSULATOR ASSY	1
302	43408041	COVER, WIRELESS	1
303	43166041	REMOTE CONTROLLER, WIRELESS	1
304	43183036	HOLDER, REMOTE, CONTROLLER	1
305	43459022	P.C. BOARD ASSY	1
306	43460132	LEAD ASSY	1

RBC-AXU31U-E(TR)

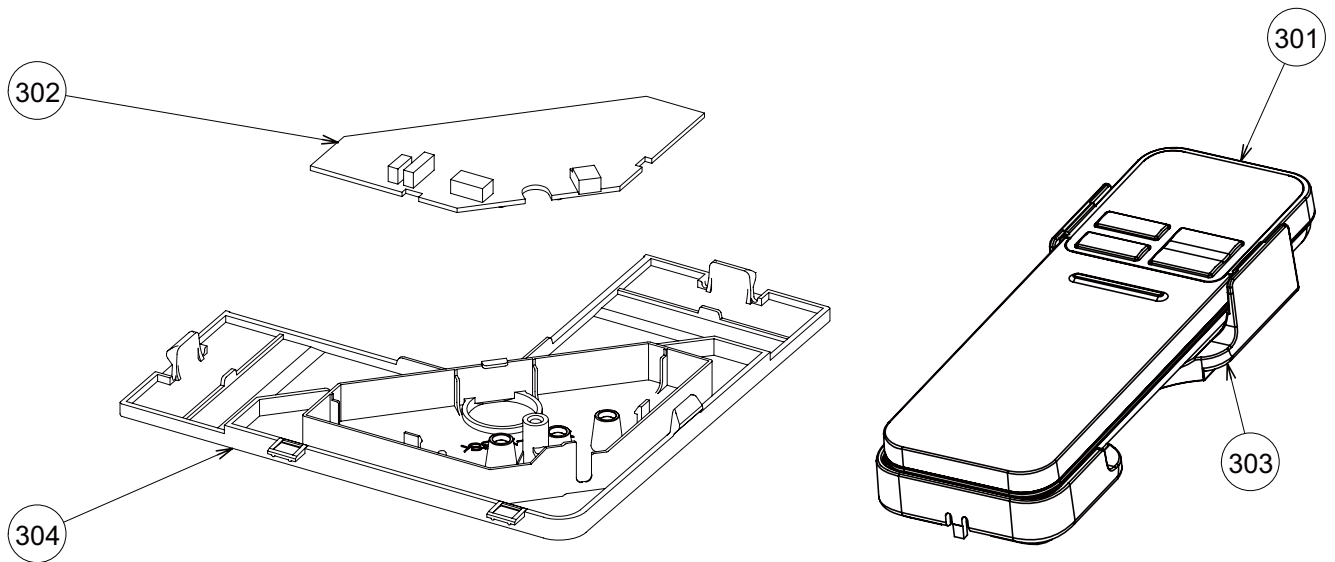

Location No.	Part No.	Description	Q'ty/Set
301	43166041	REMOTE CONTROLLER, WIRELESS	1
302	4316W013	PC BOARD ASSY	1
303	43183036	HOLDER, REMOTE, CONTROLLER	1
304	43108018	COVER, PANEL WRS	1



RBC-AXU31UM-E(TR)

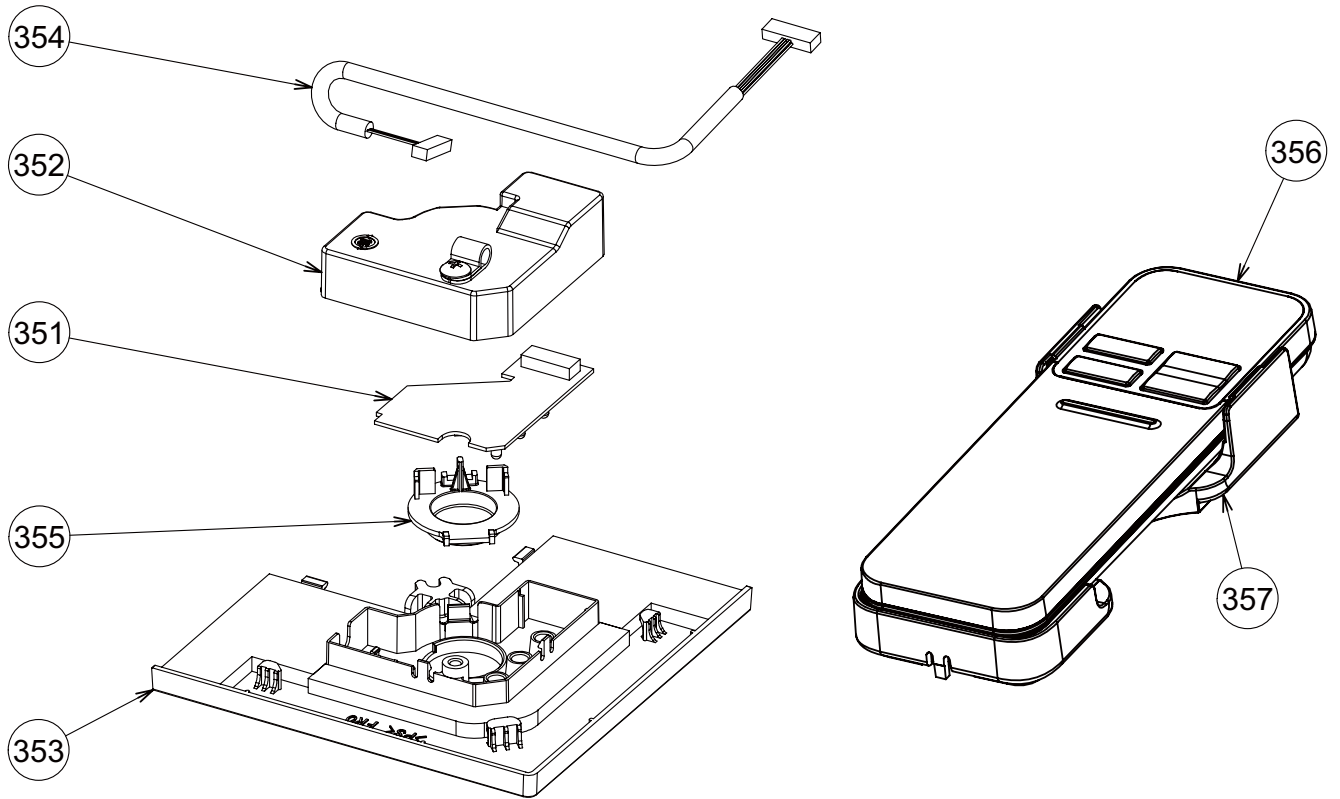

Location No.	Part No.	Description	Q'ty/Set
351	4316V616	P.C. BOARD ASSY, REMOTE RECIEVER	1
352	43162103	COVER, WRS	1
353	43108036	COVER, PANEL WRS	1
354	43160665	LEAD	1
355	43108041	COVER, WIRELESS	1
356	43166041	REMOTE CONTROLLER, WIRELESS	1
357	43183036	HOLDER, REMOTE, CONTROLLER	1

RBC-AXU31UW-E(TR)

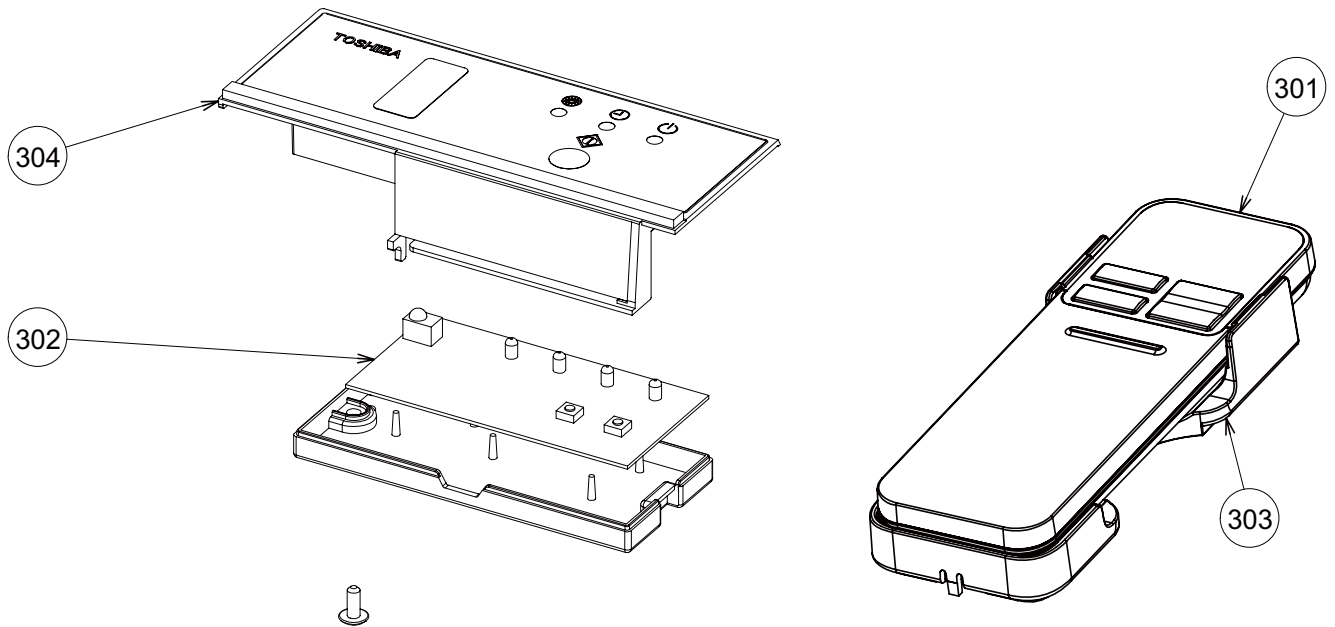

Location No.	Part No.	Description	Q'ty/Set
301	43166041	REMOTE CONTROLLER, WIRELESS	1
302	4316W014	P.C. BOARD ASSY	1
303	43183036	HOLDER, REMOTE, CONTROLLER	1
304	43108035	BASE, WIRELESS	1

RBC-AXU31C-E(TR)

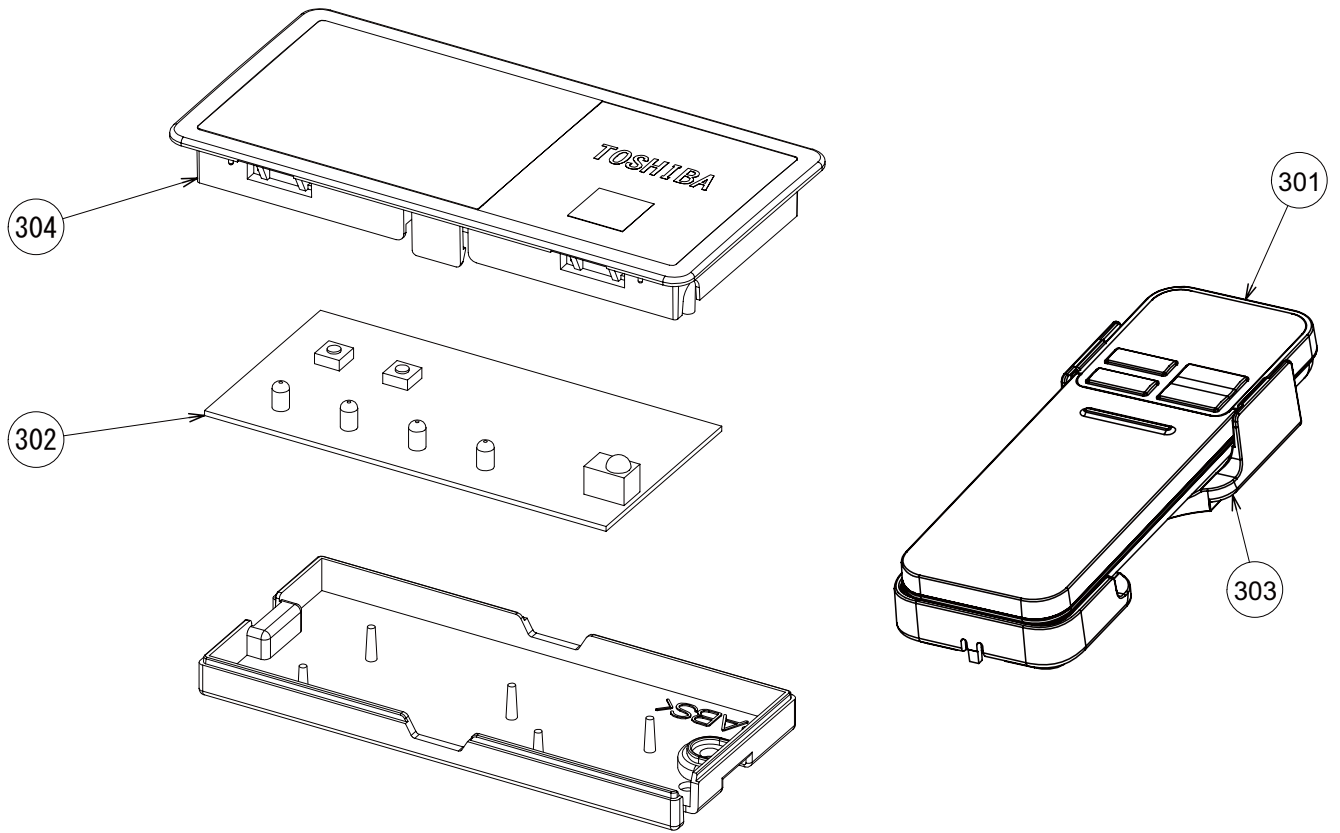

Location No.	Part No.	Description	Q'ty/Set
301	43166041	REMOTE CONTROLLER, WIRELESS	1
302	4316W014	P.C. BOARD ASSY	1
303	43183036	HOLDER, REMOTE, CONTROLLER	1
304	43108033	BASE ASSY	1

RBC-AXU31-E(TR)

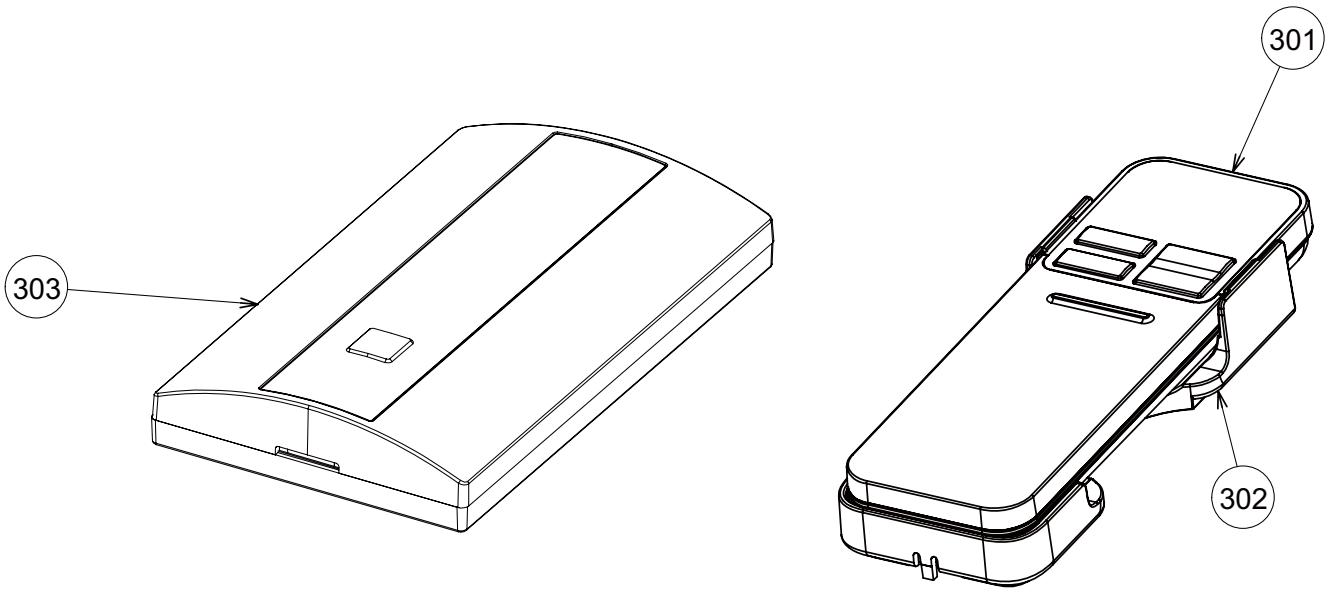

Location No.	Part No.	Description	Q'ty/Set
301	43166041	REMOTE CONTROLLER, WIRELESS	1
302	43183036	HOLDER, REMOTE, CONTROLLER	1
303	4316W015	RECIEVER, UNIT	1

# **Toshiba Carrier Corporation**

72-34 Horikawa-cho, Saiwai-ku, Kawasaki-shi, Kanagawa 212-8585, JAPAN

Copyright © 2020 TOSHIBA CARRIER CORPORATION, ALL Rights Reserved.