

TOSHIBA

SERVICE MANUAL

AIR-CONDITIONER (SPLIT TYPE)

OUTDOOR UNIT
<SUPER DIGITAL INVERTER>

RAV-GP561ATP-E

RAV-GP561ATP-TR

RAV-GP561ATJP-E

R32

INVERTER



Original instruction**Adoption of New Refrigerant**

This Air Conditioner is a new type which adopts a new refrigerant HFC (R32) instead of the conventional refrigerant R22 in order to prevent destruction of the ozone layer.

CONTENTS

SAFETY CAUTION	3
1. SPECIFICATIONS	13
1-1. Outdoor Unit	14
1-2. Operation Characteristic Curve	15
2. CONSTRUCTION VIEWS (EXTERNAL VIEWS)	16
2-1. RAV-GP561ATP*	16
3. SYSTEMATIC REFRIGERATING CYCLE DIAGRAM	18
3-1. Indoor Unit	
4. WIRING DIAGRAM	20
4-1. RAV-GP561ATP*	20
5. SPECIFICATIONS OF ELECTRICAL PARTS	21
6. REFRIGERANT R32	22
6-1. Safety During Installation/Serviceing	22
6-2. Refrigerant Piping Installation	22
6-3. Tools	26
6-4. Recharging of Refrigerant	27
6-5. Brazing of Pipes	28
6-6. Instructions for Re-use Piping of R22 or R407C	30
6-7. Replenishing refrigerant	33
7. OUTDOOR CONTROL CIRCUIT	34
7-1. Outdoor Controls	34
7-2. Outdoor Print Circuit Board	40
8. TROUBLESHOOTING	41
8-1. Summary of Troubleshooting	41
8-2. Troubleshooting	43
8-3. Table Inspection of outdoor unit main parts	63
9. OTHERS	64
9-1. Refrigerant Recovery Control	64
9-2. Various Setting on Outdoor Unit (Existing piping, Power save, Cooling-only, etc.)	66
10. DETACHMENTS	75
10-1. RAV-GP561ATP*	75
11. EXPLODED VIEWS AND PARTS LIST	83
11-1. RAV-GP561ATP*	83

SAFETY CAUTION

Please read carefully through these instructions that contain important information which complies with the "Machinery" Directive (Directive 2006/42/EC), and ensure that you understand them.

Generic Denomination: Air Conditioner

Definition of Qualified Installer or Qualified Service Person

The air conditioner must be installed, maintained, repaired and removed by a qualified installer or qualified service person.

When any of these jobs is to be done, ask a qualified installer or qualified service person to do them for you.

A qualified installer or qualified service person is an agent who has the qualifications and knowledge described in the table below.

Agent	Qualifications and knowledge which the agent must have
Qualified installer (*1)	<ul style="list-style-type: none"> • The qualified installer is a person who installs, maintains, relocates and removes the air conditioners made by Toshiba Carrier Corporation. He or she has been trained to install, maintain, relocate and remove the air conditioners made by Toshiba Carrier Corporation or, alternatively, he or she has been instructed in such operations by an individual or individuals who have been trained and is thus thoroughly acquainted with the knowledge related to these operations. • The qualified installer who is allowed to do the electrical work involved in installation, relocation and removal has the qualifications pertaining to this electrical work as stipulated by the local laws and regulations, and he or she is a person who has been trained in matters relating to electrical work on the air conditioners made by Toshiba Carrier Corporation or, alternatively, he or she has been instructed in such matters by an individual or individuals who have been trained and is thus thoroughly acquainted with the knowledge related to this work. • The qualified installer who is allowed to do the refrigerant handling and piping work involved in installation, relocation and removal has the qualifications pertaining to this refrigerant handling and piping work as stipulated by the local laws and regulations, and he or she is a person who has been trained in matters relating to refrigerant handling and piping work on the air conditioners made by Toshiba Carrier Corporation or, alternatively, he or she has been instructed in such matters by an individual or individuals who have been trained and is thus thoroughly acquainted with the knowledge related to this work. • The qualified installer who is allowed to work at heights has been trained in matters relating to working at heights with the air conditioners made by Toshiba Carrier Corporation or, alternatively, he or she has been instructed in such matters by an individual or individuals who have been trained and is thus thoroughly acquainted with the knowledge related to this work.
Qualified service person (*1)	<ul style="list-style-type: none"> • The qualified service person is a person who installs, repairs, maintains, relocates and removes the air conditioners made by Toshiba Carrier Corporation. He or she has been trained to install, repair, maintain, relocate and remove the air conditioners made by Toshiba Carrier Corporation or, alternatively, he or she has been instructed in such operations by an individual or individuals who have been trained and is thus thoroughly acquainted with the knowledge related to these operations. • The qualified service person who is allowed to do the electrical work involved in installation, repair, relocation and removal has the qualifications pertaining to this electrical work as stipulated by the local laws and regulations, and he or she is a person who has been trained in matters relating to electrical work on the air conditioners made by Toshiba Carrier Corporation or, alternatively, he or she has been instructed in such matters by an individual or individuals who have been trained and is thus thoroughly acquainted with the knowledge related to this work. • The qualified service person who is allowed to do the refrigerant handling and piping work involved in installation, repair, relocation and removal has the qualifications pertaining to this refrigerant handling and piping work as stipulated by the local laws and regulations, and he or she is a person who has been trained in matters relating to refrigerant handling and piping work on the air conditioners made by Toshiba Carrier Corporation or, alternatively, he or she has been instructed in such matters by an individual or individuals who have been trained and is thus thoroughly acquainted with the knowledge related to this work. • The qualified service person who is allowed to work at heights has been trained in matters relating to working at heights with the air conditioners made by Toshiba Carrier Corporation or, alternatively, he or she has been instructed in such matters by an individual or individuals who have been trained and is thus thoroughly acquainted with the knowledge related to this work.

Definition of Protective Gear

When the air conditioner is to be transported, installed, maintained, repaired or removed, wear protective gloves and “safety” work clothing.



In addition to such normal protective gear, wear the protective gear described below when undertaking the special work detailed in the table below.

Failure to wear the proper protective gear is dangerous because you will be more susceptible to injury, burns, electric shocks and other injuries.

Work undertaken	Protective gear worn
All types of work	Protective gloves “Safety” working clothing
Electrical-related work	Gloves to provide protection for electricians and from heat Insulating shoes Clothing to provide protection from electric shock
Work done at heights (50 cm or more)	Helmets for use in industry
Transportation of heavy objects	Shoes with additional protective toe cap
Repair of outdoor unit	Gloves to provide protection for electricians and from heat



The important contents concerned to the safety are described on the product itself and on this Service Manual. Please read this Service Manual after understanding the described items thoroughly in the following contents (Indications/Illustrated marks), and keep them.

[Explanation of indications]

Indication	Explanation
 DANGER	Indicates contents assumed that an imminent danger causing a death or serious injury of the repair engineers and the third parties when an incorrect work has been executed.
 WARNING	Indicates possibilities assumed that a danger causing a death or serious injury of the repair engineers, the third parties, and the users due to troubles of the product after work when an incorrect work has been executed.
 CAUTION	Indicates contents assumed that an injury or property damage (*) may be caused on the repair engineers, the third parties, and the users due to troubles of the product after work when an incorrect work has been executed.

* Property damage : Enlarged damage concerned to property, furniture, and domestic animal/pet

[Explanation of illustrated marks]





Mark	Explanation
	Indicates prohibited items (Forbidden items to do) The sentences near an illustrated mark describe the concrete prohibited contents.
	Indicates mandatory items (Compulsory items to do) The sentences near an illustrated mark describe the concrete mandatory contents.
	Indicates cautions (Including danger/warning) The sentences or illustration near or in an illustrated mark describe the concrete cautious contents.

Warning Indications on the Air Conditioner Unit

[Confirmation of warning label on the main unit]

Confirm that labels are indicated on the specified positions



If removing the label during parts replace, stick it as the original.

Warning indication	Description
 <p style="text-align: center;">WARNING</p> <hr/> <p style="text-align: center;">ELECTRICAL SHOCK HAZARD</p> <p>Disconnect all remote electric power supplies before servicing.</p>	<p>WARNING</p> <p>ELECTRICAL SHOCK HAZARD</p> <p>Disconnect all remote electric power supplies before servicing.</p>
 <p style="text-align: center;">WARNING</p> <hr/> <p>Moving parts. Do not operate unit with grille removed. Stop the unit before the servicing.</p>	<p>WARNING</p> <p>Moving parts. Do not operate unit with grille removed. Stop the unit before the servicing.</p>
 <p style="text-align: center;">CAUTION</p> <hr/> <p>High temperature parts. You might get burned when removing this panel.</p>	<p>CAUTION</p> <p>High temperature parts. You might get burned when removing this panel.</p>
 <p style="text-align: center;">CAUTION</p> <hr/> <p>Do not touch the aluminum fins of the unit. Doing so may result in injury.</p>	<p>CAUTION</p> <p>Do not touch the aluminum fins of the unit. Doing so may result in injury.</p>
 <p style="text-align: center;">CAUTION</p> <hr/> <p style="text-align: center;">BURST HAZARD</p> <p>Open the service valves before the operation, otherwise there might be the burst.</p>	<p>CAUTION</p> <p>BURST HAZARD</p> <p>Open the service valves before the operation, otherwise there might be the burst.</p>





Precaution for Safety

The appliance shall be installed in accordance with national wiring regulations. Capacity shortages of the power circuit or an incomplete installation may cause an electric shock or fire.







DANGER





 Turn off breaker.	Before carrying out the installation, maintenance, repair or removal work, be sure to set the circuit breaker to the OFF position. Otherwise, electric shocks may result.
	Before opening the intake grille of the indoor unit or service panel of the outdoor unit, set the circuit breaker to the OFF position. Failure to set the circuit breaker to the OFF position may result in electric shocks through contact with the interior parts. Only a qualified installer (*1) or qualified service person (*1) is allowed to remove the intake grille of the indoor unit or service panel of the outdoor unit and do the work required.
	Before starting to repair the outdoor unit fan or fan guard, be absolutely sure to set the circuit breaker to the OFF position, and place a "Work in progress" sign on the circuit breaker.
	When cleaning the filter or other parts of the indoor unit, set the circuit breaker to OFF without fail, and place a "Work in progress" sign near the circuit breaker before proceeding with the work.
 Prohibition	Do not turn ON the circuit breaker under the condition of removing a cabinet, a panel, etc. Otherwise, it leads to an electric shock with a high voltage, resulting in loss of life.





 **WARNING**



 General	<p>Before starting to repair the air conditioner, read carefully through the Service Manual, and repair the air conditioner by following its instructions.</p>
	<p>Only qualified service person (*1) is allowed to repair the air conditioner. Repair of the air conditioner by unqualified person may give rise to a fire, electric shocks, injury, water leaks and/or other problems.</p>
	<p>Only a qualified installer (*1) or qualified service person (*1) is allowed to carry out the electrical work of the air conditioner. Under no circumstances must this work be done by an unqualified individual since failure to carry out the work properly may result in electric shocks and/or electrical leaks.</p>
	<p>Wear protective gloves and safety work clothing during installation, servicing and removal.</p>
	<p>When connecting the electrical wires, repairing the electrical parts or undertaking other electrical jobs, wear gloves to provide protection for electricians, insulating shoes and clothing to provide protection from electric shocks. Failure to wear this protective gear may result in electric shocks.</p>
	<p>Use wiring that meets the specifications in the Installation Manual and the stipulations in the local regulations and laws. Use of wiring which does not meet the specifications may give rise to electric shocks, electrical leakage, smoking and/or a fire.</p>
	<p>Only a qualified installer (*1) or qualified service person (*1) is allowed to undertake work at heights using a stand of 50 cm or more.</p>
	<p>When working at heights, use a ladder which complies with the ISO 14122 standard, and follow the procedure in the ladder's instructions. Also wear a helmet for use in industry as protective gear to undertake the work.</p>
	<p>When working at heights, put a sign in place so that no-one will approach the work location, before proceeding with the work. Parts and other objects may fall from above, possibly injuring a person below.</p>
	<p>Do not touch the aluminum fin of the outdoor unit. You may injure yourself if you do so. If the fin must be touched for some reason, first put on protective gloves and safety work clothing, and then proceed.</p>
	<p>Do not climb onto or place objects on top of the outdoor unit. You may fall or the objects may fall off of the outdoor unit and result in injury.</p>
	<p>When transporting the air conditioner, wear shoes with additional protective toe caps.</p>
	<p>When transporting the air conditioner, do not take hold of the bands around the packing carton. You may injure yourself if the bands should break.</p>
<p>This air conditioner has passed the pressure test as specified in IEC 60335-2-40 Annex EE.</p>	
 Electric shock hazard	<p>When you access inside of the electric cover to repair electric parts, wait for about five minutes after turning off the breaker. Do not start repairing immediately. Otherwise you may get electric shock by touching terminals of high-voltage capacitors. Natural discharge of the capacitor takes about five minutes.</p>
 Prohibition	<p>Place a "Work in progress" sign near the circuit breaker while the installation, maintenance, repair or removal work is being carried out. There is a danger of electric shocks if the circuit breaker is set to ON by mistake.</p>
	<p>When checking the electric parts, removing the cover of the electric parts box of Indoor Unit and/or front panel of Outdoor Unit inevitably to determine the failure, put a sign "Do not enter" around the site before the work. Failure to do this may result in third person getting electric shock.</p>
	<p>Before operating the air conditioner after having completed the work, check that the electrical parts box cover of the indoor unit and service panel of the outdoor unit are closed, and set the circuit breaker to the ON position. You may receive an electric shock if the power is turned on without first conducting these checks.</p>
 Stay on protection	<p>If, in the course of carrying out repairs, it becomes absolutely necessary to check out the electrical parts with the electrical parts box cover of one or more of the indoor units and the service panel of the outdoor unit removed in order to find out exactly where the trouble lies, wear insulated heat-resistant gloves, insulated boots and insulated work overalls, and take care to avoid touching any live parts. You may receive an electric shock if you fail to heed this warning. Only qualified service person (*1) is allowed to do this kind of work.</p>

WARNING



 Check earth wires.	<p>Before troubleshooting or repair work, check the earth wire is connected to the earth terminals of the main unit, otherwise an electric shock is caused when a leak occurs. If the earth wire is not correctly connected, contact an electric engineer for rework.</p> <p>After completing the repair or relocation work, check that the earth wires are connected properly.</p> <p>Be sure to connect earth wire. (Grounding work) Incomplete earthing causes an electric shock. Do not connect earth wires to gas pipes, water pipes, and lightning rods or earth wires for telephone wires.</p>
 Prohibition of modification.	<p>Do not modify the products. Do not also disassemble or modify the parts. It may cause a fire, electric shock or injury.</p>
 Use specified parts.	<p>When any of the electrical parts are to be replaced, ensure that the replacement parts satisfy the specifications given in the Service Manual (or use the parts contained on the parts list in the Service Manual). Use of any parts which do not satisfy the required specifications may give rise to electric shocks, smoking and/or a fire.</p> <p>Replace components only with parts specified by the manufacturer. Other parts may result in the ignition of refrigerant in the atmosphere from a leak.</p>
 Do not bring a child close to the equipment.	<p>If, in the course of carrying out repairs, it becomes absolutely necessary to check out the electrical parts with the electrical parts box cover of one or more of the indoor units and the service panel of the outdoor unit removed in order to find out exactly where the trouble lies, place "Keep out" signs around the work site before proceeding.</p> <p>Third-party individuals may enter the work site and receive electric shocks if this warning is not heeded.</p>
 Insulating measures	<p>Connect the cut-off lead wires with crimp contact, etc, put the closed end side upward and then apply a water-cut method, otherwise a leak or production of fire is caused at the users' side.</p>
 No fire	<p>When performing repairs using a gas burner, replace the refrigerant with nitrogen gas because the oil that coats the pipes may otherwise burn.</p> <p>When repairing the refrigerating cycle, take the following measures.</p> <ol style="list-style-type: none"> 1) Be attentive to fire around the cycle. When using a gas stove, etc, be sure to put out fire before work; otherwise the oil mixed with refrigerant gas may catch fire. 2) Do not use a welder in the closed room. When using it without ventilation, carbon monoxide poisoning may be caused. 3) Do not bring inflammables close to the refrigerant cycle, otherwise fire of the welder may catch the inflammables.

 Refrigerant	<p>The refrigerant used by this air conditioner is the R32.</p>
	<p>Check the used refrigerant name and use tools and materials of the parts which match with it. For the products which use R32 refrigerant, the refrigerant name is indicated at a position on the outdoor unit where is easy to see. To prevent miss-charging, the route of the service port is changed from one of the former R22. Be careful for miss-charging since a charging port of R32 is the same diameter as that of R410A.</p>
	<p>Do not use any refrigerant different from the one specified for complement or replacement. Otherwise, abnormally high pressure may be generated in the refrigeration cycle, which may result in a failure or explosion of the product or an injury to your body.</p>
	<p>For an air conditioner which uses R32, never use other refrigerant than R32. For an air conditioner which uses other refrigerant (R22, R410A etc.), never use R32. If different types of refrigerant are mixed, abnormal high pressure generates in the refrigerating cycle and an injury due to breakage may be caused. If the different type of refrigerants are mixed in, be sure to recharge the refrigerant</p>
	<p>Do not charge refrigerant additionally. If charging refrigerant additionally when refrigerant gas leaks, the refrigerant composition in the refrigerating cycle changes resulted in change of air conditioner characteristics or refrigerant over the specified standard amount is charged and an abnormal high pressure is applied to the inside of the refrigerating cycle resulted in cause of breakage or injury. Therefore if the refrigerant gas leaks, recover the refrigerant in the air conditioner, execute vacuuming, and then newly recharge the specified amount of liquid refrigerant. In this time, never charge the refrigerant over the specified amount.</p>
	<p>When recharging the refrigerant in the refrigerating cycle, do not mix the refrigerant or air other than R32 into the specified refrigerant. If air or others is mixed with the refrigerant, abnormal high pressure generates in the refrigerating cycle resulted in cause of injury due to breakage.</p>
	<p>After the installation work, confirm that refrigerant gas does not leak. If refrigerant gas leaks into the room and flows near a fire source, such as a cooking range, it may generate noxious gases, causing a fire.</p>
	<p>Never recover the refrigerant into the outdoor unit. When the equipment is moved or repaired, be sure to recover the refrigerant with recovering device. The refrigerant cannot be recovered in the outdoor unit; otherwise a serious accident such as breakage or injury is caused.</p>
 Assembly/ Cabling	<p>After repair work, surely assemble the disassembled parts, and connect and lead the removed wires as before. Perform the work so that the cabinet or panel does not catch the inner wires. If incorrect assembly or incorrect wire connection was done, a disaster such as a leak or fire is caused at user's side.</p>
 Insulator check	<p>After the work has finished, be sure to use an insulation tester set (500V Megger) to check the resistance is 1MΩ or more between the charge section and the non-charge metal section (Earth position). If the resistance value is low, a disaster such as a leak or electric shock is caused at user's side.</p>
 Ventilation	<p>When the refrigerant gas leaks during work, execute ventilation. If the refrigerant gas touches to a fire, it may generate noxious gases, causing a fire. A case of leakage of the refrigerant and the closed room full with gas is dangerous because a shortage of oxygen occurs. Be sure to execute ventilation. If refrigerant gas has leaked during the installation work, ventilate the room immediately. If the leaked refrigerant gas comes in contact with fire, it may generate noxious gases, causing a fire.</p>

 <p>Compulsion</p>	<p>When the refrigerant gas leaks, find up the leaked position and repair it surely. If the leaked position cannot be found up and the repair work is interrupted, pump-down and tighten the service valve, otherwise the refrigerant gas may leak into the room. When gas touches to fire such as fan heater, stove or cooking stove, it may generate noxious gases, causing a fire though the refrigerant gas itself is innocuous. When installing equipment which includes a large amount of charged refrigerant such as a multi air conditioner in a sub-room, it is necessary that the density does not the limit even if the refrigerant leaks. If the refrigerant leaks and exceeds the limit density, an accident of shortage of oxygen is caused.</p> <p>Tighten the flare nut with a torque wrench in the specified manner. Excessive tighten of the flare nut may cause a crack in the flare nut after a long period, which may result in refrigerant leakage.</p> <p>Nitrogen gas must be used for the airtight test.</p> <p>The charge hose must be connected in such a way that it is not slack.</p> <p>For the installation/moving/reinstallation work, follow to the Installation Manual. If an incorrect installation is done, a trouble of the refrigerating cycle, water leak, electric shock or fire is caused.</p> <p>Install the outdoor unit properly in a location that is durable enough to support the weight of the outdoor unit. Insufficient durability may cause the outdoor unit to fall, which may result in injury.</p>
 <p>Check after repair</p>	<p>Once the repair work has been completed, check for refrigerant leaks, and check the insulation resistance and water drainage. Then perform a trial run to check that the air conditioner is running properly.</p> <p>After repair work has finished, check there is no trouble. If check is not executed, a fire, electric shock or injury may be caused. For a check, turn off the power breaker.</p> <p>After repair work (installation of front panel and cabinet) has finished, execute a test run to check there is no generation of smoke or abnormal sound. If check is not executed, a fire or an electric shock is caused. Before test run, install the front panel and cabinet.</p>
 <p>Do not operate the unit with the valve closed.</p>	<p>Check the following matters before a test run after repairing piping.</p> <ul style="list-style-type: none"> • Connect the pipes surely and there is no leak of refrigerant. • The valve is opened. <p>Running the compressor under condition that the valve closes causes an abnormal high pressure resulted in damage of the parts of the compressor and etc. and moreover if there is leak of refrigerant at connecting section of pipes, the air is suctioned and causes further abnormal high pressure resulted in burst or injury.</p>
 <p>Check after reinstallation</p>	<p>Only a qualified installer (*1) or qualified service person (*1) is allowed to relocate the air conditioner. It is dangerous for the air conditioner to be relocated by an unqualified individual since a fire, electric shocks, injury, water leakage, noise and/or vibration may result.</p> <p>Check the following items after reinstallation.</p> <ol style="list-style-type: none"> 1) The earth wire is correctly connected. 2) The power cord is not caught in the product. 3) There is no inclination or unsteadiness and the installation is stable. <p>If check is not executed, a fire, an electric shock or an injury is caused.</p>
 <p>Cooling check</p>	<p>When the service panel of the outdoor unit is to be opened in order for the compressor or the area around this part to be repaired immediately after the air conditioner has been shut down, set the circuit breaker to the OFF position, and then wait at least 10 minutes before opening the service panel. If you fail to heed this warning, you will run the risk of burning yourself because the compressor pipes and other parts will be very hot to the touch. In addition, before proceeding with the repair work, wear the kind of insulated heat-resistant gloves designed to protect electricians.</p> <p>When the service panel of the outdoor unit is to be opened in order for the fan motor, reactor, inverter or the areas around these parts to be repaired immediately after the air conditioner has been shut down, set the circuit breaker to the OFF position, and then wait at least 10 minutes before opening the service panel. If you fail to heed this warning, you will run the risk of burning yourself because the fan motor, reactor, inverter heat sink and other parts will be very hot to the touch. In addition, before proceeding with the repair work, wear the kind of insulated heat-resistant gloves designed to protect electricians.</p>

 Installation	Only a qualified installer (*1) or qualified service person (*1) is allowed to install the air conditioner. If the air conditioner is installed by an unqualified individual, a fire, electric shocks, injury, water leakage, noise and/or vibration may result.
	Before starting to install the air conditioner, read carefully through the Installation Manual, and follow its instructions to install the air conditioner.
	Do not install the air conditioner in a location that may be subject to a risk of exposure to a combustible gas. If a combustible gas leaks and becomes concentrated around the unit, a fire may occur.
	When transporting the air conditioner, use a forklift and when moving the air conditioner by hand, move the unit with 4 people.
	Install a circuit breaker that meets the specifications in the installation manual and the stipulations in the local regulations and laws.
	Install the circuit breaker where it can be easily accessed by the agent.
	Do not place any combustion appliance in a place where it is directly exposed to the wind of air conditioner, otherwise it may cause imperfect combustion.
 Compulsion	When carrying out the pump-down work shut down the compressor before disconnecting the refrigerant pipe. Disconnecting the refrigerant pipe with the service valve left open and the compressor still operating will cause air, etc. to be sucked in, raising the pressure inside the refrigeration cycle to an abnormally high level, and possibly resulting in reputing, injury, etc.
	When removing the welding parts of suction and discharge pipe for the compressor, remove them at the place ventilated well after recovering the refrigerant. Improper recovering may cause the spurt of the refrigerant and the refrigeration oil, causing an injury.
 Prohibition	Do not vent gases to the atmosphere. Venting gases to the atmosphere is prohibited by the law.

 **CAUTION**

 Wearing of gloves	Ensure wearing of gloves when performing any work in order to avoid injury from parts, etc. Failure to wear the proper protective gloves cause an injury due to the parts, etc.
 Confirm	When performing the welding work, check whether refrigerant leaks or remains. If the leakage refrigerant gas touches a fire source, it may generate noxious gases, causing a fire.

Explanations given to user

- If you have discovered that the fan grille is damaged, do not approach the outdoor unit but set the circuit breaker to the OFF position, and contact a qualified service person to have the repairs done.
Do not set the circuit breaker to the ON position until the repairs are completed.

Relocation

- Only a qualified installer (*1) or qualified service person (*1) is allowed to relocate the air conditioner. It is dangerous for the air conditioner to be relocated by an unqualified individual since a fire, electric shocks, injury, water leakage, noise and/or vibration may result.
- When carrying out the pump-down work shut down the compressor before disconnecting the refrigerant pipe. Disconnecting the refrigerant pipe with the service valve left open and the compressor still operating will cause air, etc. to be sucked in, raising the pressure inside the refrigeration cycle to an abnormally high level, and possibly resulting in reputing, injury, etc.

(*1) Refer to the "Definition of Qualified Installer or Qualified Service Person."

Declaration of Conformity

Manufacturer: TOSHIBA CARRIER (THAILAND) CO., LTD.
144 / 9 Moo 5, Bangkadi Industrial Park, Tivanon Road,
Amphur Muang, Pathumthani 12000, Thailand

Authorized Nick Ball

Representative/TCF holder: Toshiba EMEA Engineering Director
Toshiba Carrier UK Ltd.
Porsham Close, Belliver Industrial Estate,
PLYMOUTH, Devon, PL6 7DB.
United Kingdom

Hereby declares that the machinery described below:

Generic Denomination: Air Conditioner

Model/type: RAV-GP561ATP-E RAV-GP561ATP-TR RAV-GP561ATJP-E

Commercial name: Super Digital Inverter Series Air Conditioner

Complies with the provisions of the "Machinery" Directive (Directive 2006/42/EC) and the regulations transposing into national law.

Complies with the provisions of the following harmonized standard:

EN 378-2: 2008 + A2:2012

Note: This declaration becomes invalid if technical or operational modifications are introduced without the manufacturer's consent.

Disposal

How to dispose of air conditioners with a rating of 12 kW and below in accordance with the 2002/96/EC Directive WEEE (Waste Electrical and Electronic Equipment) is provided in the Installation Manual supplied with your product. For disposal of the product above 12 kW in rating you should use a registered company in accordance with any national or EU legislation.

<Model names with a rating of 12 kW and below (outdoor units)>

SDI series

RAV-GP561ATP-E RAV-GP561ATP-TR RAV-GP561ATJP-E

Specifications

Model	Sound power level (dBA)		Weight (kg)
	Cooling	Heating	
RAV-GP561ATP-E	*	*	45
RAV-GP561ATP-TR	*	*	45
RAV-GP561ATJP-E	*	*	45

* Under 70 dBA

1. SPECIFICATIONS

1-1. Outdoor Unit

<Super Digital Inverter>

Model name	Outdoor unit	RAV-	GP561ATP*
Power supply			1 phase 220-240V 50Hz (Power exclusive to outdoor is required.)
Compressor	Type		Hermetic compressor
	Motor	(kW)	1.1
	Pole		4
Refrigerant charged			(kg) 1.35
Refrigerant control			Pulse motor valve
Inter connecting pipe	Standard length		(m) 7.5
	Min. length		(m) 5
	Max. total length		(m) 50
	Additional refrigerant charge under long piping connector		20g/m (21m to 50m)
	Height difference	Outdoor lower	(m) 30
Outdoor higher		(m) 30	
Outer dimension	Height		(mm) 630
	Width		(mm) 799
	Depth		(mm) 299
Appearance			Silky shade (Muncel 1Y8.5/0.5)
Total weight			(kg) 45
Heat exchanger			Finned tube
Fan unit	Fan		Propeller fan
	Standard air flow high		(m ³ /min.) 40
	Motor		(W) 43
Connecting pipe	Gas side		(mm) 12.7
	Liquid side		(mm) 6.4
Sound pressure level		Cooling/Heating (dB·A)	46/48
Sound power level		Cooling/Heating (dB·A)	63/65
Outside air temperature, Cooling		(°C)	52 to -15
Outside air temperature, Heating		(°C)	15 to -27

1-2. Operation Characteristic Curve

RAV-GP561ATP*

<Cooling>

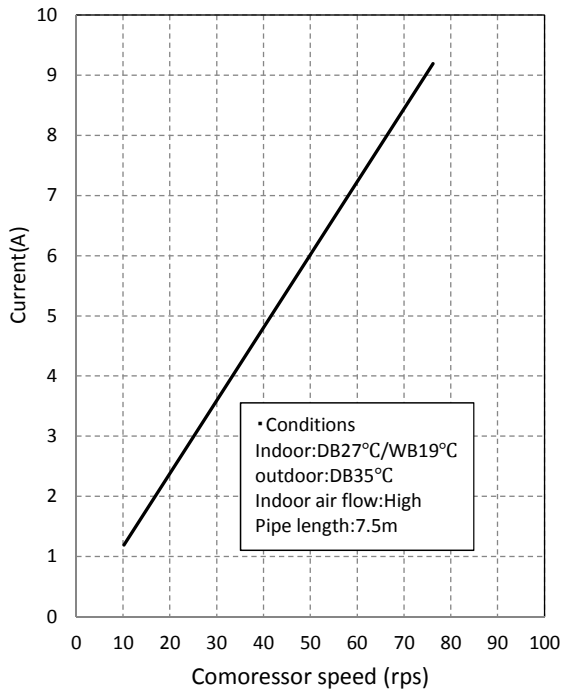

<Heating>

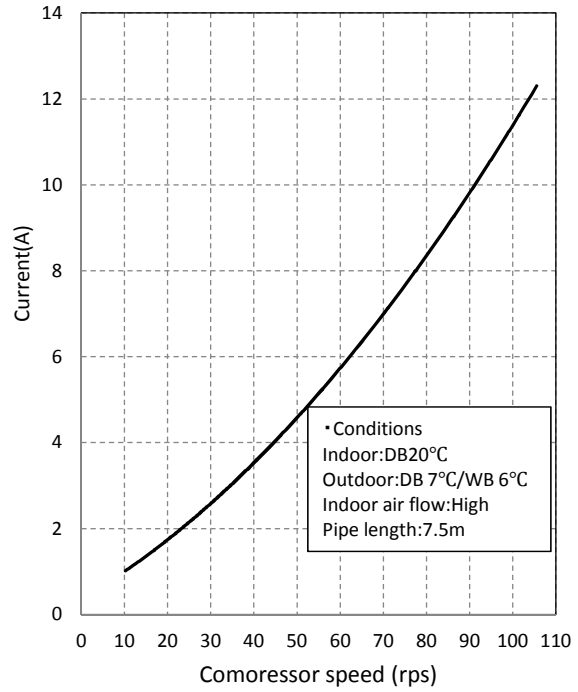

• Capacity variation ratio according to temperature

RAV-GP561ATP*

<Cooling>

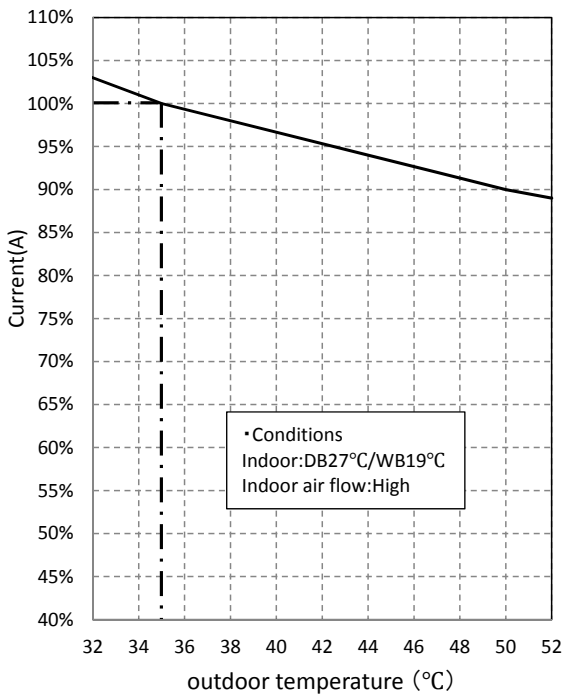

<Heating>

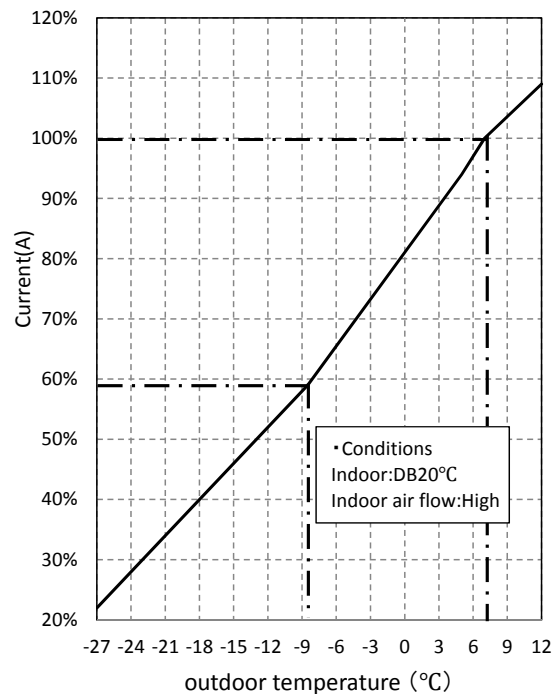

2. CONSTRUCTION VIEWS (EXTERNAL VIEWS)

2-1. RAV-GP561ATP*

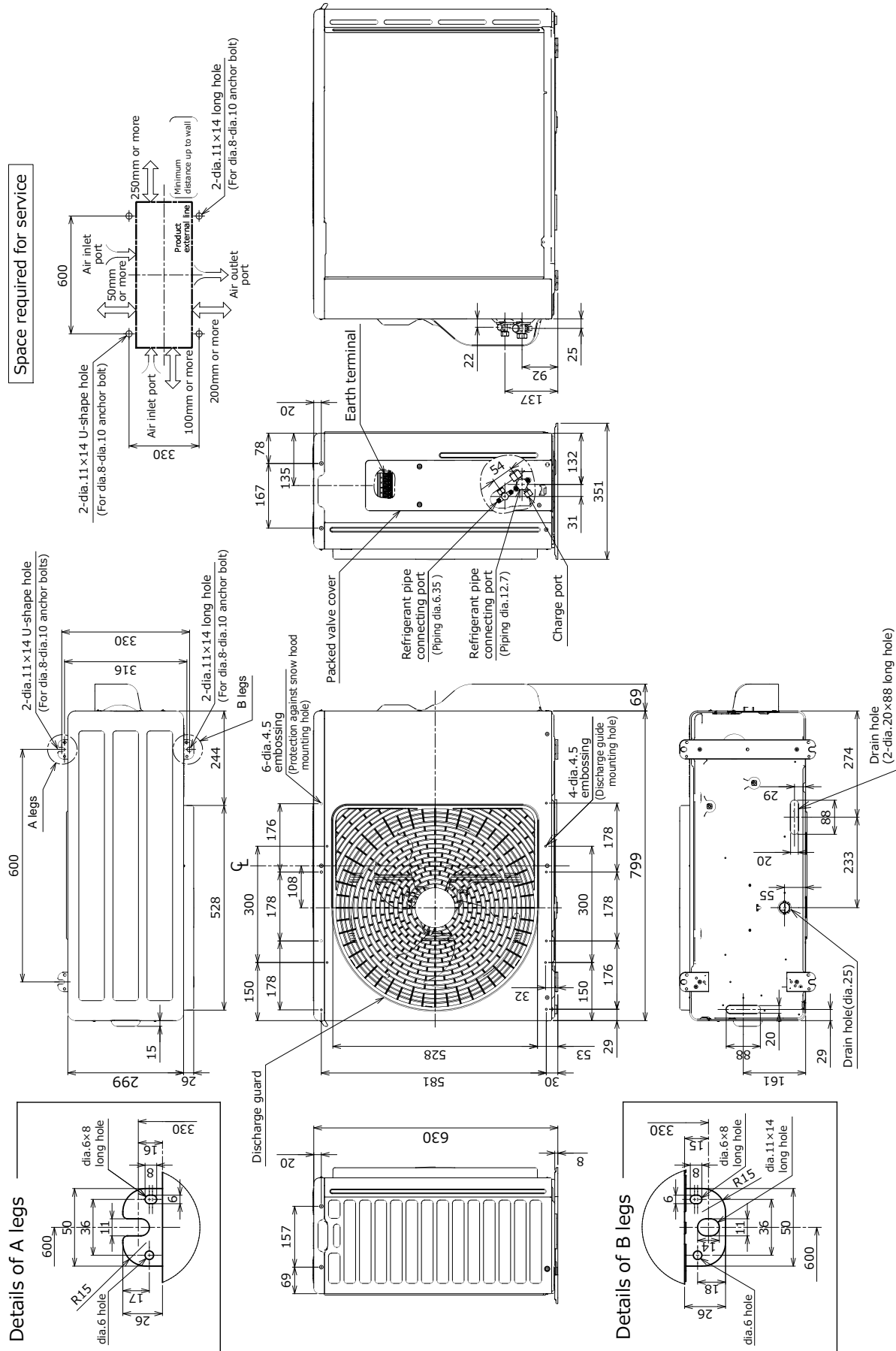

RAV-TWP30E2, RAV-TWP50E2 (Simultaneous Twin)

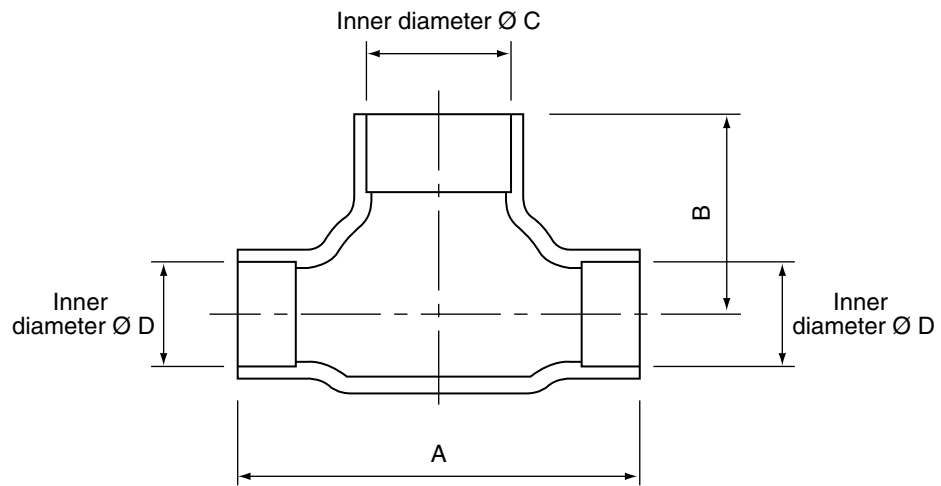

Model (RBC-)		A	B	C	D
TWP30E2	Liquid side	36	14	Ø9.5	Ø6.4
	Gas side	43	23	Ø15.9	Ø12.7
TWP50E2	Liquid side	34	14	Ø9.5	Ø9.5
	Gas side	44	21	Ø15.9	Ø15.9

3. SYSTEMATIC REFRIGERATING CYCLE DIAGRAM

3-1. Indoor Unit

- Single type (Combination of 1 indoor unit and 1 outdoor unit)

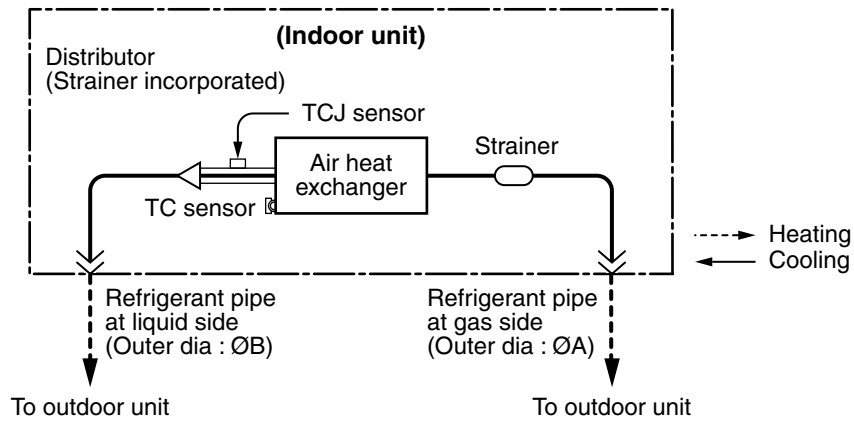

Dimension table

Indoor unit	Outer diameter of refrigerant pipe	
	Gas side ØA	Liquid side ØB
GP56 type	12.7	6.4

RAV-GP561ATP*

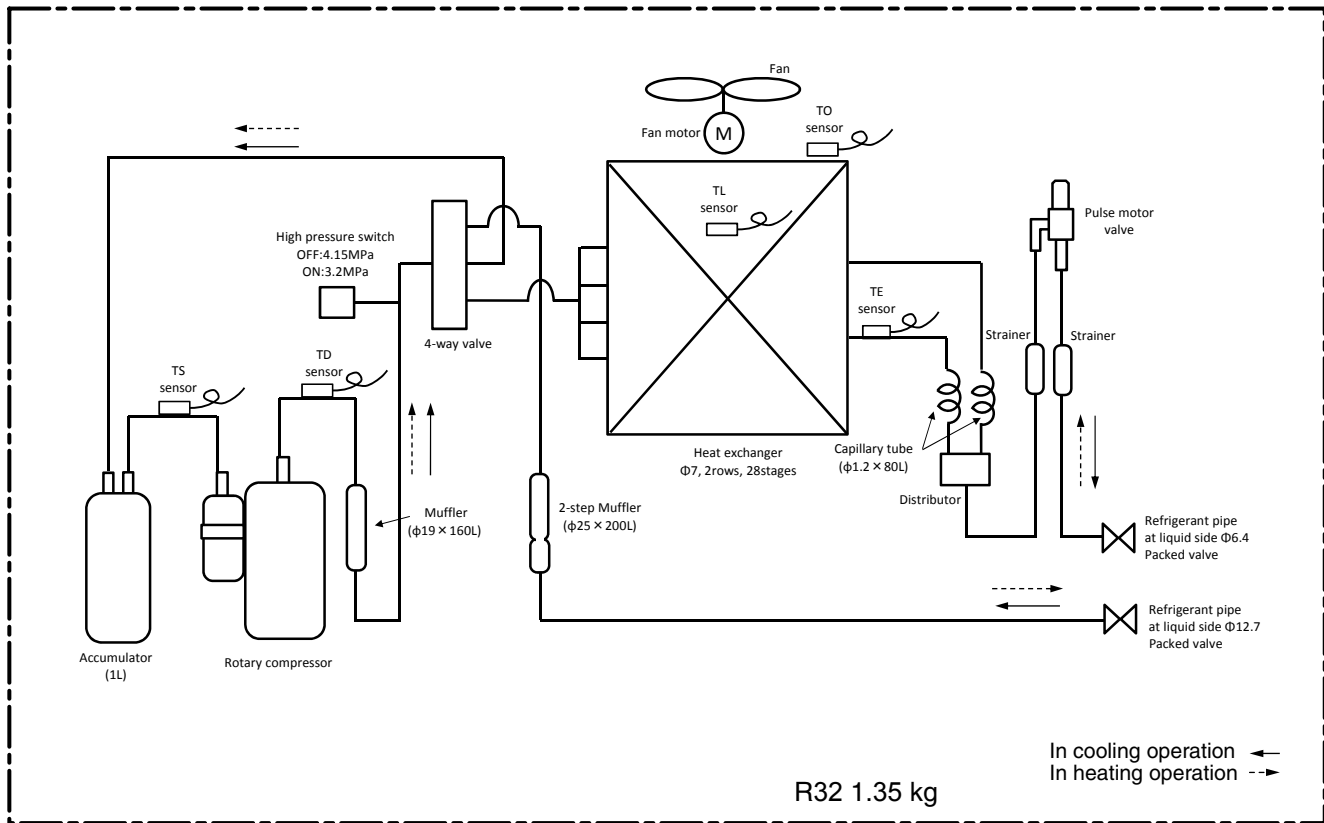

		Pressure				Pipe surface temperature (°C)				Compressor drive revolution frequency (rps)	Indoor fan	Indoor/Outdoor temp. conditions (DB/WB) (°C)	
		(MPa)		(kg/cm ² g)		Discharge	Suction	Indoor heat exchanger	Outdoor heat exchanger			Indoor	Outdoor
		Pd	Ps	Pd	Ps	(TD)	(TS)	(TC)	(TE)				
Cooling	Standard	2.84	1.04	29.0	10.6	81	14	13	36	50	HIGH	27 / 19	35 / -
	Overload	3.48	1.50	35.5	15.3	75	24	23	55	25	HIGH	32 / 24	52 / -
	Low load	2.41	0.80	24.6	8.2	53	6	7	23	34	LOW	18 / 15.5	-15 / -
Heating	Standard	2.43	0.70	24.8	7.1	80	2	38	4	62	HIGH	20 / -	7 / 6
	Overload	3.37	1.15	34.4	11.7	85	16	52	17	44	LOW	30 / -	24 / 18
	Low load	1.63	0.12	16.6	1.2	26	-29	25	-23	106	HIGH	15 / -	-27 / -

5. SPECIFICATIONS OF ELECTRICAL PARTS

RAV-GP561ATP*

No.	Parts name	Type	Specifications
1	Compressor	DX150A1T-21F	3 phase, 4P, 1100 W
2	Fan motor	ICF-140-A43-1	Output 43 W
3	4-way valve coil	STF-H01AZ1724A1	-
4	PMV coil	PQ-M10012-000313	-
5	P.C. board	MCC-1713	-
6	Reactor	CH-102-Z-T	18mH, 16A
7	Fuse (Switching power (Protect))	-	T3.15A, AC 250V
8	Fuse (Inverter, input (Current protect))	-	AC240V
9	Outdoor temp. sensor (To sensor)	-	10 kΩ at 25°C
10	Heat exchanger sensor (Te sensor)	-	10 kΩ at 25°C
11	Suction temp. sensor (Ts sensor)	-	10 kΩ at 25°C
12	Discharge temp. sensor (Td sensor)	-	50 kΩ at 25°C
13	Compressor thermo. (Protection)	CS-12AL	OFF: 125 ± 4°C, ON: 90 ± 5°C

6. REFRIGERANT R32

This air conditioner adopts the new refrigerant HFC (R32) which does not damage the ozone layer.

The next section describes the precautions for air conditioner using the new refrigerant. Conforming to contents of the next section together with the general cautions included in this manual, perform the correct and safe work.

6-1. Safety During Installation/Service

The basic installation servicing work procedures are the same as conventional R410A models.

As R32's pressure is about 1.6 times higher than that of R22, improper installation/servicing may cause a serious trouble. By using tools and materials exclusive for R32, it is necessary to carry out installation/servicing safely while taking the following precautions into consideration.

1. Never use refrigerant other than R32 in an air conditioner which is designed to operate with R32. If other refrigerant than R32 is mixed, pressure in the refrigeration cycle becomes abnormally high, and it may cause personal injury, etc. by a rupture.
2. Confirm the used refrigerant name, and use tools and materials exclusive for the refrigerant. The refrigerant name R32 is indicated on the visible place of the outdoor unit of the air conditioner using R32 as refrigerant. To prevent mischarging, the diameter of the service port differs from that of R22. R32 and other HFCs are heavier than air, and therefore they are inclined to settle near the floor surface. If the gas fills up the room or the bottom part of a room, it may also cause oxygen deficiency and may reach its combustion concentration.
In order to prevent oxygen deficiency and R32 combustion, keep the room well-ventilated for a healthy work environment.
In particular, using HFCs in a basement room or confined area creates a higher risk; be sure to furnish the room with local exhaust ventilation. If a refrigerant leak is confirmed in a room an inadequately ventilated location, do not use a flame until the area has been ventilated appropriately and the work environment has been improved.
The same applies in case of brazing, ensure appropriate ventilation to prevent oxygen deficiency and R32 combustion.
Check that there are no dangerous or combustible items nearby, and ensure a fire extinguisher is close at hand.
Keep a sufficient distance away from causes of fire (ignition sources) such as gas-burning equipment and electric heaters in places where installation, repairs, or similar work on air-conditioning equipment is performed.
3. If a refrigeration gas leakage occurs during installation/servicing, be sure to ventilate fully. If the refrigerant gas comes into contact with fire, a poisonous gas may occur.
4. When installing or removing an air conditioner, do not allow air moisture dust or oil to remain in the refrigeration cycle. Otherwise, pressure in the refrigeration cycle may become abnormally high so that a rupture or personal injury may be caused.
5. After completion of installation work, check to make sure that there is no refrigeration gas leakage. If the refrigerant gas leaks into the room, coming into contact with fire in the fan-driven heater, space heater, etc., a poisonous gas may occur
6. When an air conditioning system charged with a large volume of refrigerant is installed in a small room, it is necessary to exercise care so that, even when refrigerant leaks, its concentration does not exceed the marginal level. If the refrigerant gas leakage occurs and its concentration exceeds the marginal level, an oxygen starvation accident may result.
7. Be sure to carry out installation or removal according to the installation manual. Improper installation may cause refrigeration trouble, water leakage, electric shock, fire, etc.
8. Unauthorized modifications to the air conditioner may be dangerous. If a breakdown occurs please call a qualified air conditioner technician or electrician. Improper repair's may result in water leakage, electric shock and fire, etc.

6-2. Refrigerant Piping Installation

6-2-1. Piping Materials and Joints Used

For the refrigerant piping installation, copper pipes and joints are mainly used. Copper pipes and joints suitable for the refrigerant must be chosen and installed. Furthermore, it is necessary to use clean copper pipes and joints whose interior surfaces are less affected by contaminants.

1. Copper Pipes

It is necessary to use seamless copper pipes which are made of either copper or copper alloy and it is desirable that the amount of residual oil is less than 40 mg/10 m. Do not use copper pipes having a collapsed, deformed or discolored portion (especially on the interior surface).

Otherwise, the expansion valve or capillary tube may become blocked with contaminants.

As an air conditioner using R32 incurs pressure higher than when using R22, it is necessary to choose adequate materials.

Thicknesses of copper pipes used with R32 are as shown in Table 3-2-1. Never use copper pipes thinner than 0.8 mm even when it is available on the market.

Table 6-2-1 Thicknesses of annealed copper pipes

		Thickness (mm)	
Nominal diameter	Outer diameter (mm)	R32(R410A)	R22
1/4	6.35	0.80	0.80
3/8	9.52	0.80	0.80
1/2	12.70	0.80	0.80
5/8	15.88	1.00	1.00

2. Joints

For copper pipes, flare joints or socket joints are used. Prior to use, be sure to remove all contaminants.

a) Flare Joints

Flare joints used to connect the copper pipes cannot be used for pipings whose outer diameter exceeds 20 mm. In such a case, socket joints can be used.

Sizes of flare pipe ends, flare joint ends and flare nuts are as shown in Tables 3-2-3 to 3-2-6 below.

b) Socket Joints

Socket joints are such that they are brazed for connections, and used mainly for thick pipings whose diameter is larger than 20 mm.

Thicknesses of socket joints are as shown in Table 6-2-2.

Table 6-2-2 Minimum thicknesses of socket joints

Nominal diameter	Reference outer diameter of copper pipe jointed (mm)	Minimum joint thickness (mm)
1/4	6.35	0.50
3/8	9.52	0.60
1/2	12.70	0.70
5/8	15.88	0.80

6-2-2. Processing of Piping Materials

When performing the refrigerant piping installation, care should be taken to ensure that water or dust does not enter the pipe interior, that no other oil than lubricating oils used in the installed air-water heat pump is used, and that refrigerant does not leak. When using lubricating oils in the piping processing, use such lubricating oils whose water content has been removed. When stored, be sure to seal the container with an airtight cap or any other cover.

1. Flare processing procedures and precautions

a) Cutting the Pipe

By means of a pipe cutter, slowly cut the pipe so that it is not deformed.

b) Removing Burrs and Chips

If the flared section has chips or burrs, refrigerant leakage may occur.

Carefully remove all burrs and clean the cut surface before installation.

c) Insertion of Flare Nut

d) Flare Processing

Make certain that a clamp bar and copper pipe have been cleaned.

By means of the clamp bar, perform the flare processing correctly.

Use either a flare tool for R32 or conventional flare tool.

Flare processing dimensions differ according to the type of flare tool. When using a conventional flare tool, be sure to secure "dimension A" by using a gauge for size adjustment.

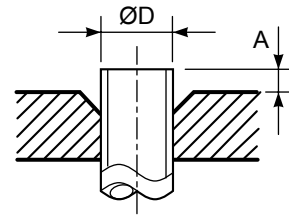

Fig. 6-2-1 Flare processing dimensions

Table 6-2-3 Dimensions related to flare processing for R32(R410A)

Nominal diameter	Outer diameter (mm)	Thickness (mm)	A (mm)		
			Flare tool for R32 clutch type	Conventional flare tool	
				Clutch type	Wing nut type
1/4	6.35	0.8	0 to 0.5	1.0 to 1.5	1.5 to 2.0
3/8	9.52	0.8	0 to 0.5	1.0 to 1.5	1.5 to 2.0
1/2	12.70	0.8	0 to 0.5	1.0 to 1.5	2.0 to 2.5
5/8	15.88	1.0	0 to 0.5	1.0 to 1.5	2.0 to 2.5

Table 6-2-4 Dimensions related to flare processing for R22

Nominal diameter	Outer diameter (mm)	Thickness (mm)	A (mm)		
			Flare tool for R22 clutch type	Conventional flare tool	
				Clutch type	Wing nut type
1/4	6.35	0.8	0 to 0.5	0.5 to 1.0	1.0 to 1.5
3/8	9.52	0.8	0 to 0.5	0.5 to 1.0	1.0 to 1.5
1/2	12.70	0.8	0 to 0.5	0.5 to 1.0	1.5 to 2.0
5/8	15.88	1.0	0 to 0.5	0.5 to 1.0	1.5 to 2.0

Table 6-2-5 Flare and flare nut dimensions for R32(R410A)

Nominal diameter	Outer diameter (mm)	Thickness (mm)	Dimension (mm)				Flare nut width (mm)
			A	B	C	D	
1/4	6.35	0.8	9.1	9.2	6.5	13	17
3/8	9.52	0.8	13.2	13.5	9.7	20	22
1/2	12.70	0.8	16.6	16.0	12.9	23	26
5/8	15.88	1.0	19.7	19.0	16.0	25	29

Table 6-2-6 Flare and flare nut dimensions for R22

Nominal diameter	Outer diameter (mm)	Thickness (mm)	Dimension (mm)				Flare nut width (mm)
			A	B	C	D	
1/4	6.35	0.8	9.0	9.2	6.5	13	17
3/8	9.52	0.8	13.0	13.5	9.7	20	22
1/2	12.70	0.8	16.2	16.0	12.9	20	24
5/8	15.88	1.0	19.7	19.0	16.0	23	27
3/4	19.05	1.0	23.3	24.0	19.2	34	36

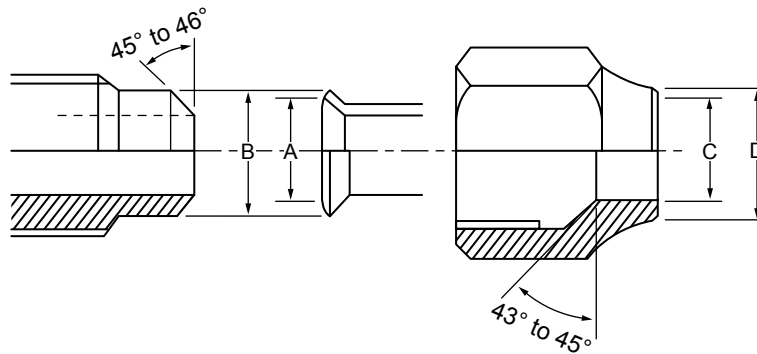

Fig. 6-2-2 Relations between flare nut and flare seal surface

2. Flare Connecting Procedures and Precautions

- a) Make sure that the flare and union portions do not have any scar or dust, etc.
- b) Correctly align the processed flare surface with the union axis.
- c) Tighten the flare with designated torque by means of a torque wrench. The tightening torque for R32 is the same as that for conventional R22. Incidentally, when the torque is weak, the gas leakage may occur. When it is strong, the flare nut may crack and may be made non-removable. When choosing the tightening torque, comply with values designated by manufacturers. Table 3-2-7 shows reference values.

NOTE :

When applying oil to the flare surface, be sure to use oil designated by the manufacturer. If any other oil is used, the lubricating oils may deteriorate and cause the compressor to burn out.

Table 6-2-7 Tightening torque of flare for R32(R410A) [Reference values]

Nominal diameter	Outer diameter (mm)	Tightening torque N•m (kgf•cm)	Tightening torque of torque wrenches available on the market N•m (kgf•cm)
1/4	6.35	14 to 18 (140 to 180)	16 (160), 18 (180)
3/8	9.52	33 to 42 (330 to 420)	42 (420)
1/2	12.70	50 to 62 (500 to 620)	55 (550)
5/8	15.88	63 to 77 (630 to 770)	65 (650)

6-3. Tools

6-3-1. Required Tools

The service port diameter of packed valve of the outdoor unit in the air-water heat pump using R32 is changed to prevent mixing of other refrigerant. To reinforce the pressure-resisting strength, flare processing dimensions and opposite side dimension of flare nut (For Ø12.7 copper pipe) of the refrigerant piping are lengthened.

The used refrigerating oil is changed, and mixing of oil may cause a trouble such as generation of sludge, clogging of capillary, etc. Accordingly, the tools to be used are classified into the following three types.

1. Tools exclusive for R32 (Those which cannot be used for conventional refrigerant (R22))
2. Tools exclusive for R32, but can be also used for conventional refrigerant (R22)
3. Tools commonly used for R32 and for conventional refrigerant (R22)

The table below shows the tools exclusive for R32 and their interchangeability.

Tools exclusive for R32 (The following tools for R410A are required.)

Tools whose specifications are changed for R32 and their interchangeability

No.	Used tool	Usage	R32(R410A) air-water heat pump installation		Conventional air-water heat pump installation
			Existence of new equipment for R32	Whether conven- tional equipment can be used	Whether new equipment can be used with conventional refrigerant
1	Flare tool	Pipe flaring	Yes	*(Note 1)	○
2	Copper pipe gauge for adjusting projection margin	Flaring by conventional flare tool	Yes	*(Note 1)	*(Note 1)
3	Torque wrench (For Ø12.7)	Connection of flare nut	Yes	✕	✕
4	Gauge manifold	Evacuating, refrigerant charge, run check, etc.	Yes	✕	✕
5	Charge hose				
6	Vacuum pump adapter	Vacuum evacuating	Yes	✕	○
7	Electronic balance for refrigerant charging	Refrigerant charge	Yes	✕	○
8	Leakage detector	Gas leakage check	Yes	✕	○

(Note 1) When flaring is carried out for R32(R410A) using the conventional flare tools, adjustment of projection margin is necessary. For this adjustment, a copper pipe gauge, etc. are necessary.

General tools (Conventional tools can be used.)

In addition to the above exclusive tools, the following equipments which serve also for R22 are necessary as the general tools.

- | | | |
|--|-----------------------------|---|
| 1. Vacuum pump
Use vacuum pump by attaching
vacuum pump adapter. | 4. Reamer | 9. Hole core drill (Ø65) |
| 2. Torque wrench (For Ø6.35, Ø9.52) | 5. Pipe bender | 10. Hexagon wrench
(Opposite side 4mm) |
| 3. Pipe cutter | 6. Level vial | 11. Tape measure |
| | 7. Screwdriver (+, -) | 12. Metal saw |
| | 8. Spanner or Monkey wrench | |

Also prepare the following equipments for other installation method and run check.

- | | |
|----------------|---------------------------------|
| 1. Clamp meter | 3. Insulation resistance tester |
| 2. Thermometer | 4. Electroscop |

6-4. Recharging of Refrigerant

When it is necessary to recharge refrigerant, charge the specified amount of new refrigerant according to the following steps.

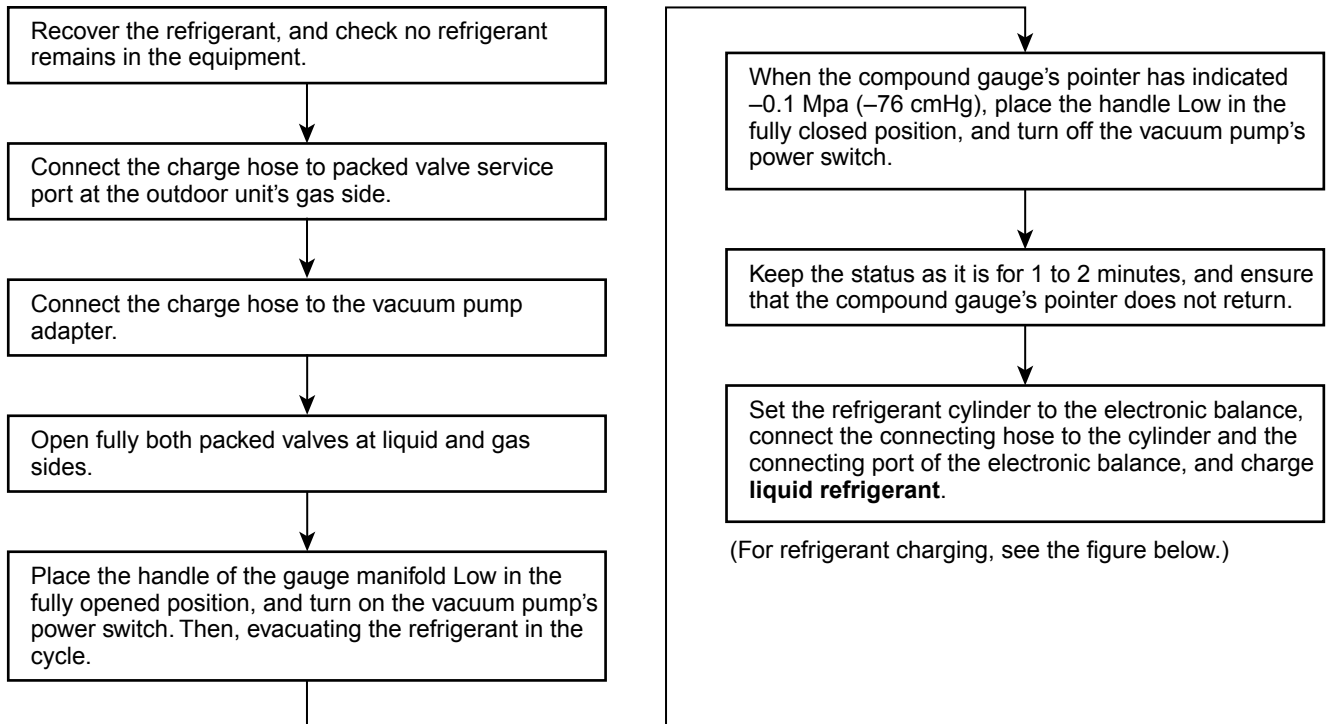

1. Never charge refrigerant exceeding the specified amount.
2. If the specified amount of refrigerant cannot be charged, charge refrigerant **bit by bit** in COOL mode.
3. Do not carry out additional charging.

When additional charging is carried out if refrigerant leaks, the refrigerant composition changes in the refrigeration cycle, that is characteristics of the air conditioner changes, refrigerant exceeding the specified amount is charged, and working pressure in the refrigeration cycle becomes abnormally high pressure, and may cause a rupture or personal injury.

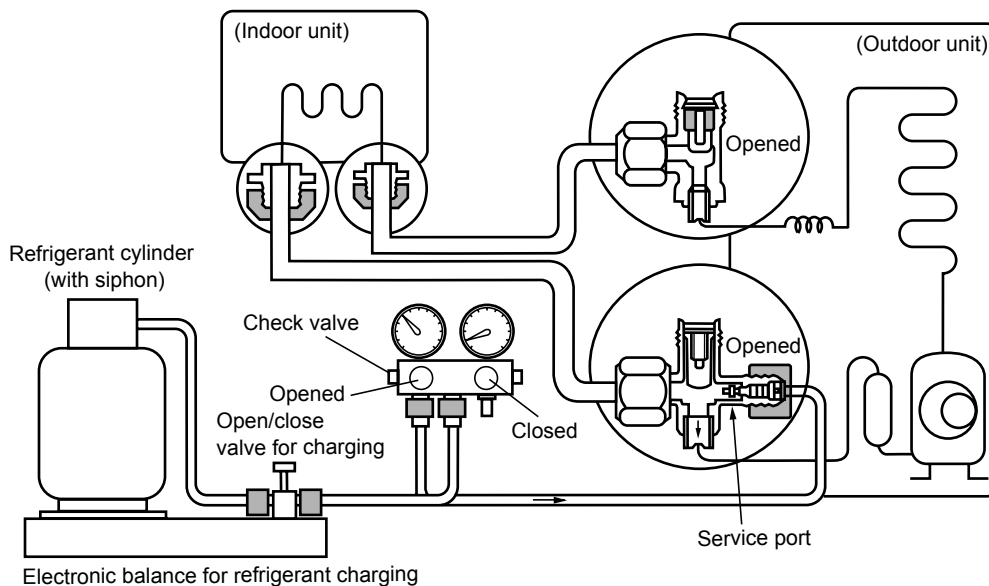

Fig. 6-4-1 Configuration of refrigerant charging

1. Be sure to make setting so that **liquid** can be charged.
2. When using a cylinder equipped with a siphon, liquid can be charged without turning it upside down.

Accordingly, when charging refrigerant from the refrigerant cylinder to the equipment, charge it turning the cylinder upside down if cylinder is not equipped with siphon.

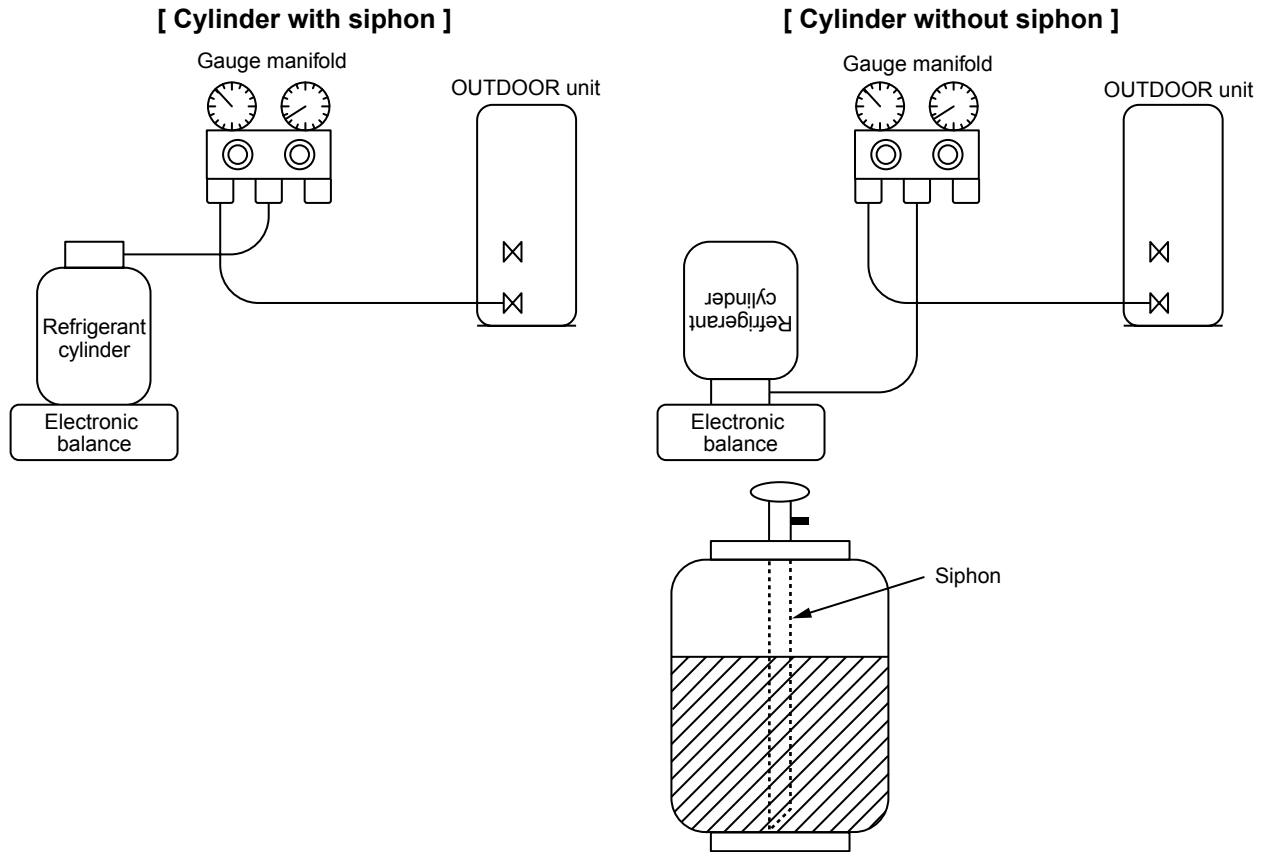

Fig. 6-4-2

6-5. Brazing of Pipes

6-5-1. Materials for Brazing

1. Silver brazing filler

Silver brazing filler is an alloy mainly composed of silver and copper. It is used to join iron, copper or copper alloy, and is relatively expensive though it excels in solderability.

2. Phosphor bronze brazing filler

Phosphor bronze brazing filler is generally used to join copper or copper alloy.

3. Low temperature brazing filler

Low temperature brazing filler is generally called solder, and is an alloy of tin and lead. Since it is weak in adhesive strength, do not use it for refrigerant pipes.

1. Phosphor bronze brazing filler tends to react with sulfur and produce a fragile compound water solution, which may cause a gas leakage. Therefore, use any other type of brazing filler at a hot spring resort, etc., and coat the surface with a paint.
2. When performing brazing again at time of servicing, use the same type of brazing filler.

6-5-2. Flux

1. Reason why flux is necessary

- By removing the oxide film and any foreign matter on the metal surface, it assists the flow of brazing filler.
- In the brazing process, it prevents the metal surface from being oxidized.
- By reducing the brazing filler's surface tension, the brazing filler adheres better to the treated metal.

2. Characteristics required for flux

- Activated temperature of flux coincides with the brazing temperature.
- Due to a wide effective temperature range, flux is hard to carbonize.
- It is easy to remove slag after brazing.
- The corrosive action to the treated metal and brazing filler is minimum.
- It excels in coating performance and is harmless to the human body.

As the flux works in a complicated manner as described above, it is necessary to select an adequate type of flux according to the type and shape of treated metal, type of brazing filler and brazing method, etc.

3. Types of flux

• Noncorrosive flux

Generally, it is a compound of borax and boric acid.

It is effective in case where the brazing temperature is higher than 800°C.

• Activated flux

Most of fluxes generally used for silver brazing are this type.

It features an increased oxide film removing capability due to the addition of compounds such as potassium fluoride, potassium chloride and sodium fluoride to the borax-boric acid compound.

4. Piping materials for brazing and used brazing filler/flux

Piping material	Used brazing filler	Used flux
Copper - Copper	Phosphor copper	Do not use
Copper - Iron	Silver	Paste flux
Iron - Iron	Silver	Vapor flux

1. Do not enter flux into the refrigeration cycle.
2. When chlorine contained in the flux remains within the pipe, the lubricating oil deteriorates. Therefore, use a flux which does not contain chlorine.
3. When adding water to the flux, use water which does not contain chlorine (e.g. distilled water or ion-exchange water).
4. Remove the flux after brazing.

6-5-3. Brazing

As brazing work requires sophisticated techniques, experiences based upon a theoretical knowledge, it must be performed by a person qualified.

In order to prevent the oxide film from occurring in the pipe interior during brazing, it is effective to proceed with brazing while letting dry Nitrogen gas (N₂) flow.

Never use gas other than Nitrogen gas.

1. Brazing method to prevent oxidation

- 1) Attach a reducing valve and a flow-meter to the Nitrogen gas cylinder.
- 2) Use a copper pipe to direct the piping material, and attach a flow-meter to the cylinder.
- 3) Apply a seal onto the clearance between the piping material and inserted copper pipe for Nitrogen in order to prevent backflow of the Nitrogen gas.
- 4) When the Nitrogen gas is flowing, be sure to keep the piping end open.
- 5) Adjust the flow rate of Nitrogen gas so that it is lower than 0.05 m³/Hr or 0.02 MPa (0.2kgf/cm²) by means of the reducing valve.
- 6) After performing the steps above, keep the Nitrogen gas flowing until the pipe cools down to a certain extent (temperature at which pipes are touchable with hands).
- 7) Remove the flux completely after brazing.

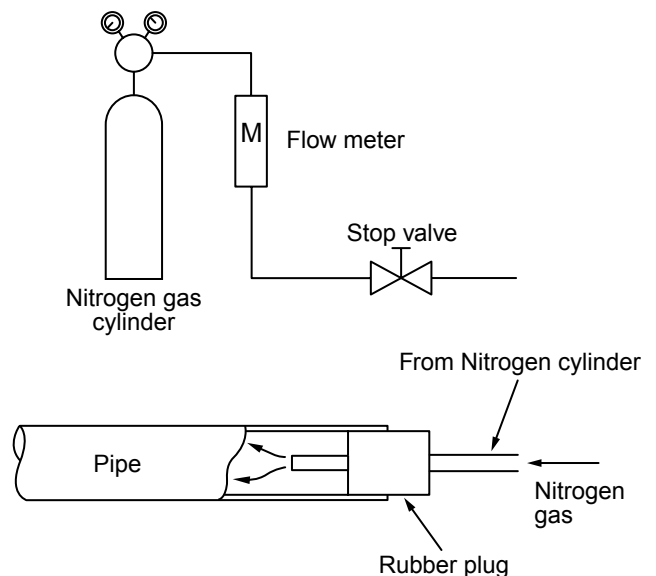

Fig. 6-5-1 Prevention of oxidation during brazing

6-6. Instructions for Re-use Piping of R22 or R407C

Instruction of Works:

The existing R22 and R407C piping can be reused for our digital inverter R410A products installations.

NOTE)

Confirmation of existence of scratch or dent of the former pipes to be applied and also confirmation of reliability of the pipe strength are conventionally referred to the local site.

If the definite conditions can be cleared, it is possible to update the existing R22 and R407C pipes to those for R410A models.

6-6-1. Basic Conditions Needed to Reuse the Existing Pipe

Check and observe three conditions of the refrigerant piping works.

1. Dry (There is no moisture inside of the pipes.)
2. Clean (There is no dust inside of the pipes.)
3. Tight (There is no refrigerant leak.)

6-6-2. Restricted Items to Use the Existing Pipes

In the following cases, the existing pipes cannot be reused as they are. Clean the existing pipes or exchange them with new pipes.

1. When a scratch or dent is heavy, be sure to use the new pipes for the works.
2. When the thickness of the existing pipe is thinner than the specified "Pipe diameter and thickness" be sure to use the new pipes for the works.
 - The operating pressure of R32 is high. If there is a scratch or dent on the pipe or thinner pipe is used, the pressure strength is poor and may cause break-age of the pipe at the worst.

* Pipe diameter and thickness (mm)

Pipe outer diameter	Ø6.4	Ø9.5	Ø12.7	Ø15.9	Ø19.0
Thickness	0.8	0.8	0.8	1.0	1.0

- In case that the pipe diameter is Ø12.7 mm or less and the thickness is less than 0.7 mm, be sure to use the new pipes for works.
3. The pipes are left as coming out or gas leaks. (Poor refrigerant)
 - There is possibility that rain water or air including moisture enters in the pipe.
 4. Refrigerant recovery is impossible. (Refrigerant recovery by the pump-down operation on the existing air conditioner)
 - There is possibility that a large quantity of poor oil or moisture remains inside of the pipe.
 5. A dryer on the market is attached to the existing pipes.
 - There is possibility that copper green rust generated.

6. Check the oil when the existing air conditioner was removed after refrigerant had been recovered. In this case, if the oil is judged as clearly different compared with normal oil
 - The refrigerator oil is copper rust green : There is possibility that moisture is mixed with the oil and rust generates inside of the pipe.
 - There is discolored oil, a large quantity of the remains, or bad smell.
 - A large quantity of sparkle remained wear-out powder is observed in the refrigerator oil.
7. The air conditioner which compressor was exchanged due to a faulty compressor.

When the discolored oil, a large quantity of the remains, mixture of foreign matter, or a large quantity of sparkle remained wear-out powder is observed, the cause of trouble will occur.
8. Installation and removal of the air conditioner are repeated with temporary installation by lease and etc.
9. In case that type of the refrigerator oil of the existing air conditioner is other than the following oil (Mineral oil), Suniso, Freol-S, MS (Synthetic oil), alkyl benzene (HAB, Barrel-freeze), ester series, PVE only of ether series.
 - Winding-insulation of the compressor may become inferior.

NOTE)

The above descriptions are results of confirmation by our company and they are views on our air conditioners, but they do not guarantee the use of the existing pipes of the air conditioner that adopted R32 in other companies.

6-6-3. Branching Pipe for Simultaneous Operation System

- In the concurrent twin system, when TOSHIBA-specified branching pipe is used, it can be reused. Branching pipe model name: RBC-TWP30E-2. On the existing air conditioner for simultaneous operation system (twin system), there is a case of using branch pipe that has insufficient compressive strength. In this case please change it to the branch pipe for R32.

6-6-4. Curing of Pipes

When removing and opening the indoor unit or outdoor unit for a long time, cure the pipes as follows:

- Otherwise rust may generate when moisture or foreign matter due to dewing enters in the pipes.
- The rust cannot be removed by cleaning, and a new piping work is necessary.

Place position	Term	Curing manner
Outdoors	1 month or more	Pinching
	Less than 1 month	Pinching or taping
Indoors	Every time	

6-6-5. Final Installation Checks

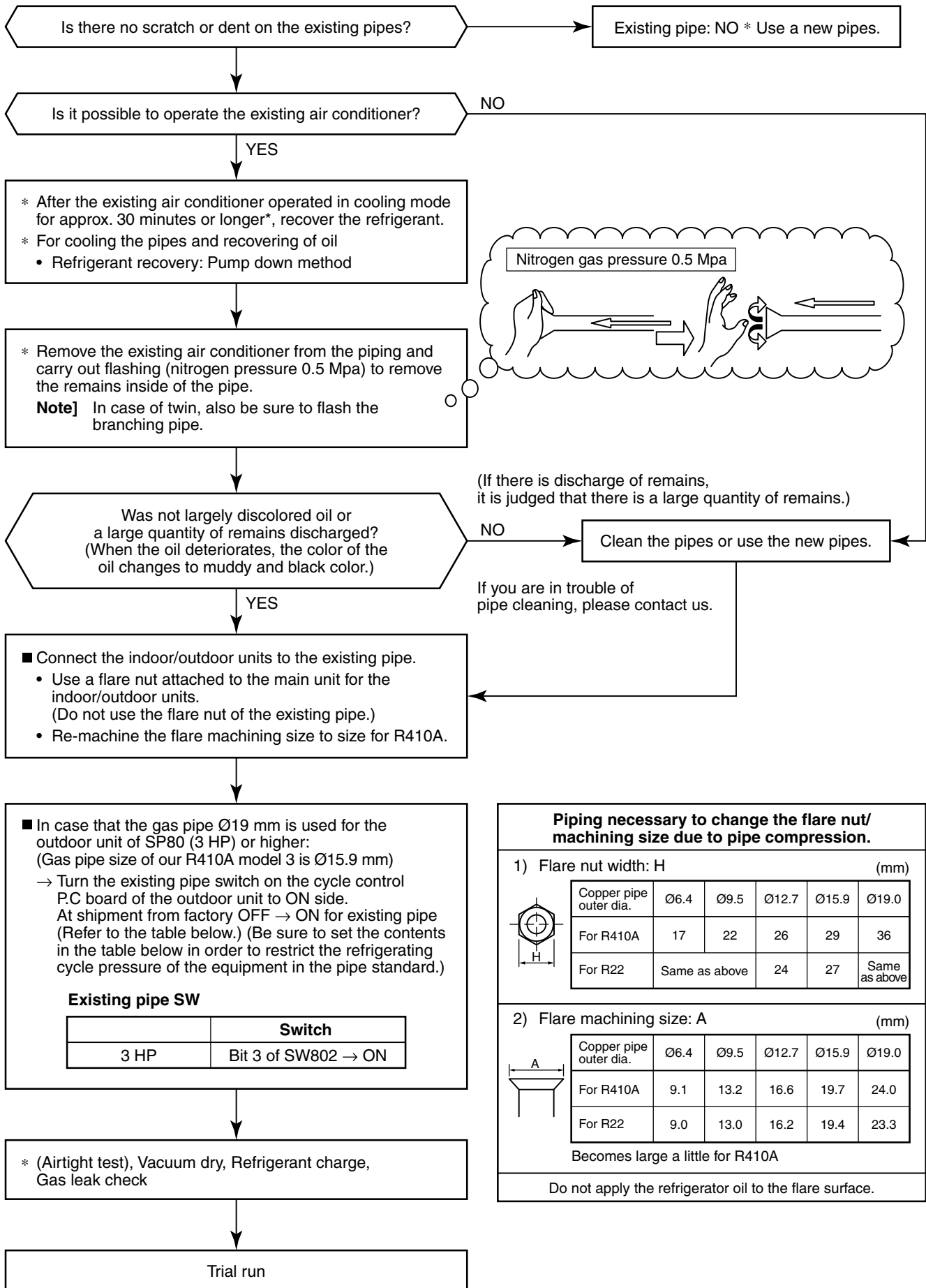

Piping necessary to change the flare nut/ machining size due to pipe compression.

1) Flare nut width: H (mm)

Copper pipe outer dia.	$\varnothing 6.4$	$\varnothing 9.5$	$\varnothing 12.7$	$\varnothing 15.9$	$\varnothing 19.0$
For R410A	17	22	26	29	36
For R22	Same as above		24	27	Same as above

2) Flare machining size: A (mm)

Copper pipe outer dia.	$\varnothing 6.4$	$\varnothing 9.5$	$\varnothing 12.7$	$\varnothing 15.9$	$\varnothing 19.0$
For R410A	9.1	13.2	16.6	19.7	24.0
For R22	9.0	13.0	16.2	19.4	23.3

Becomes large a little for R410A

Do not apply the refrigerator oil to the flare surface.

6-6-6. Handling of Existing Pipe

When using the existing pipe, carefully check it for the following:

- Wall thickness (within the specified range)
- Scratches and dents
- Water, oil, dirt, or dust in the pipe
- Flare looseness and leakage from welds
- Deterioration of copper pipe and heat insulator

Cautions for using existing pipe

- Do not reuse the flare to prevent gas leak.
Replace it with the supplied flare nut and then process it to a flare.
- Blow nitrogen gas or use an appropriate means to keep the inside of the pipe clean.
If discolored oil or much residue is discharged, wash the pipe.
- Check welds, if any, on the pipe for gas leak.
When the pipe corresponds to any of the following, do not use it. Install a new pipe instead.
- The pipe has been open (disconnected from indoor unit or outdoor unit) for a long period.
- The pipe has been connected to an outdoor unit that does not use refrigerant R22, R410A or R407C.
- The existing pipe must have a wall thickness equal to or larger than the following thickness.

Reference outside diameter (mm)	Wall thickness (mm)
Ø9.5	0.8
Ø15.9	1.0
Ø19.1	1.0

- Never use any pipe with a wall thickness less than these thicknesses due to insufficient pressure capacity.

6-7. Replenishing refrigerant

In order to assure the reliability of the appliance, the amount of refrigerant to be replenished shall be subject to the following restrictions. Follow the margin of excess replenished refrigerant, which is equivalent to the current R22. Otherwise, abnormally high pressure may be generated in the refrigeration cycle, which may result in failure, explosion of the product, or personal injury.

[Possible gas leakage]

Recharging refrigerant is allowed only if it is confirmed that the amount of leakage (e.g. slow leakage upon installation) is within the additional margin specified below.

The amount of leakage is not certain if the product does not function properly (e.g. insufficient cooling / heating performance). In such case, recover the refrigerant and replenish the refrigerant.

[Restrictions for the amount of additional charging]

- a. The amount of refrigerant additionally charged shall not exceed 10% of that specified. If the situation is not solved with such amount, recover the refrigerant completely and charge the specified amount.
- b. In case of slow leakage upon installation and the pipe connection length of not over 15m, further tighten the flare nut or take other effective measures. Do not recharge the refrigerant.

[Cautions for recharging with refrigerant]

- a. Use a scale with an accuracy of at least 10g to recharge the refrigerant. Do not use a bathroom scale.
- b. If the refrigerant leaks, identify the source and make sure to repair it. The refrigerant gas is not hazardous, but if it touches a heat source (e.g. fan heater, stove), a poisonous gas may be generated.
- c. Use liquid refrigerant for replenishment. Replenish the refrigerant carefully and slowly.

7. OUTDOOR CONTROL CIRCUIT

7-1. Outdoor Controls

1. PMV (Pulse Motor Valve) control

- 1) PMV is controlled between (GP56: 32 to 500) pulsed during operation.
- 2) In cooling operation, PMV is usually controlled with the temperature difference between TS sensor and TC sensor aiming (GP56: 1 to 5K) as the target value.
- 3) In heating operation, PMV is usually controlled with the temperature difference between TS sensor and TE sensor aiming (GP56: -1 to 4K) as the target value.
- 4) When the cycle excessively heated in both cooling and heating operation, PMV is controlled by TD sensor. The target value is 92°C for both cooling and heating operations in GP56.

REQUIREMENT

A sensor trouble may cause a liquid back-flow or abnormal overheat resulting in excessive shortening of the compressor life.

In a case of trouble on the compressor, be sure to check there is no error in the resistance value or the refrigerating cycle of each sensor after repair and then start the operation.

2. Discharge temperature release control

- 1) When the discharge temperature did not fall or the discharge temperature rapidly went up by PMV control, this control lowers the operation frequency. It subdivides the frequency control up to 0.6Hz to stabilize the cycle.
- 2) When the discharge temperature detected an abnormal stop zone, the compressor stops and then restarts after 2 minutes 30 seconds. The error counting is cleared when the operation continued for 10 minutes. If the error is detected by 4 times without clearing, the error is determined and restarting is not performed.
 - * The cause is considered as excessively little amount of refrigerant, PMV error or clogging of the cycle.
- 3) For displayed contents of error, confirm on the check code list.

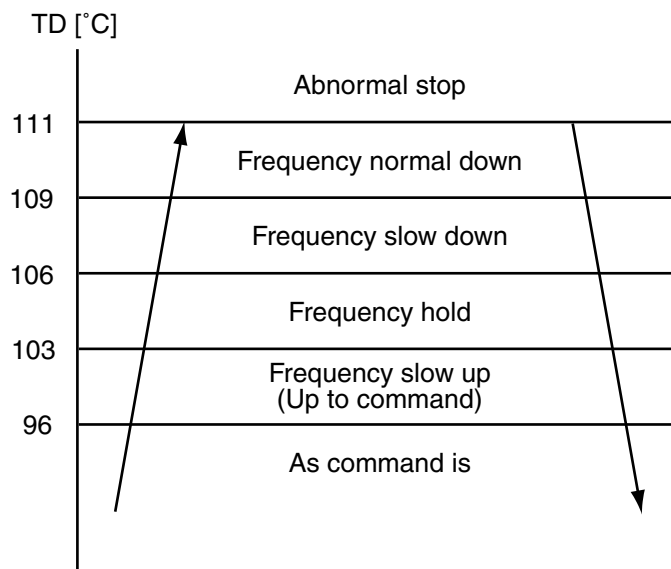

3. Outdoor fan control

Revolution frequency allocation of fan taps [rpm]

	W1	W2	W3	W4	W5	W6	W7	W8	W9	WA	WB	WC	WD	WE	WF
GP56	240	320	320	390	400	470	510	550	560	570	570	650	700	750	830

3-1) Cooling fan control

<GP56>

- ① The outdoor fan is controlled by TL sensor, TO sensor and the operation frequency.
The outdoor fan is controlled by every 1 tap of DC fan control (15 taps).
- ② Only for 60 seconds after the operation has started, the maximum fan tap corresponding to the zone in the following table is fixed and then the fan is controlled by temperature of TL sensor.

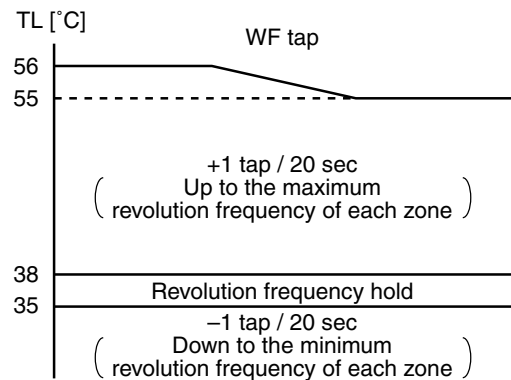
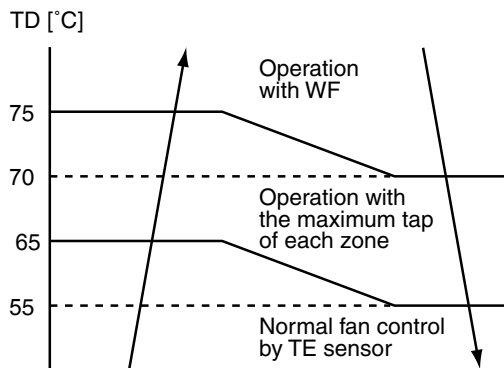

<GP56>

Temp. range	20 Hz or lower		20Hz to 45Hz		45Hz or higher	
	Min.	Max.	Min.	Max.	Min.	Max.
38°C ≤ TO	W6	WC	W8	WF	WA	WF
29°C ≤ TO < 38°C	W5	WB	W7	WD	W9	WD
15°C ≤ TO < 29°C	W4	W8	W6	WA	W8	WC
5°C ≤ TO < 15°C	W3	W6	W5	W8	W7	WA
0°C ≤ TO < 5°C	W2	W4	W4	W6	W5	W8
-4°C ≤ TO < 0°C	W2	W3	W3	W5	W4	W6
TO < -4°C	OFF	OFF	OFF	W1	OFF	W1
TO error	OFF	WC	OFF	WF	OFF	WF

3-2) Heating fan control

- ① The outdoor fan is controlled by TE sensor, TO sensor and the operation frequency.
(Control from minimum W1 to maximum (according to the following table))
- ② For 3 minutes after the operation has started, the maximum fan tap corresponding to the zone in the following table is fixed and then the fan is controlled by temperature of TE sensor.

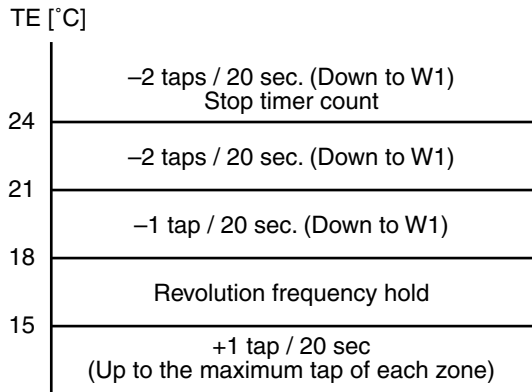

- ③ When $TE \geq 24^{\circ}\text{C}$ continues for 5 minutes, the compressor stops.
It is the same status as the normal THERMO OFF without error display.
The compressor restarts after approx. 2 minutes 30 seconds and this intermittent operation is not abnormal.
- ④ In case that the status in item ③ generates frequently, stain on filter of the suction part of the indoor unit is considered.
Clean the filter and then restart the operation.

<GP56>

Temp. range	20 Hz or lower	20Hz to 36Hz	36Hz or higher
	Max.	Max.	Max.
$10^{\circ}\text{C} \leq \text{TO}$	WA	WB	WC
$5^{\circ}\text{C} \leq \text{TO} < 10^{\circ}\text{C}$	WC	WC	WC
$-3^{\circ}\text{C} \leq \text{TO} < 5^{\circ}\text{C}$	WC	WC	WF
$-10^{\circ}\text{C} \leq \text{TO} < -3^{\circ}\text{C}$	WF	WF	WF
$\text{TO} < -10^{\circ}\text{C}$	WF	WF	WF
TO error	WF	WF	WF

4. Coil heating control

- 1) This control function heats the compressor by turning on the stopped compressor instead of a case heater.
It purposes to prevent stagnation of the refrigerant inside of the compressor.
- 2) As usual, turn on power of the compressor for the specified time before a test run after installation; otherwise a trouble of the compressor may be caused.
As same as a test run, it is recommended to turn on power of the compressor beforehand when starting operation after power of the compressor has been interrupted and left as it is for a long time.
- 3) SP80 judgment for electricity is performed by TD and TO sensors.
If TO sensor is defective, a backup control is automatically performed by TE sensor.
For a case of defective TO sensor, judge it with outdoor LED display.
Using TD sensor and TE sensor, SP40 to SP56 judges the power-on.
- 4) For every model, the power is turned off when TD is 30°C or more.

• Power-ON condition TD < 30°C

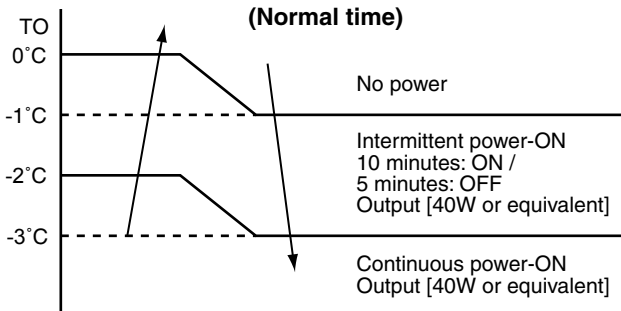

• Power-ON condition TD < 30°C

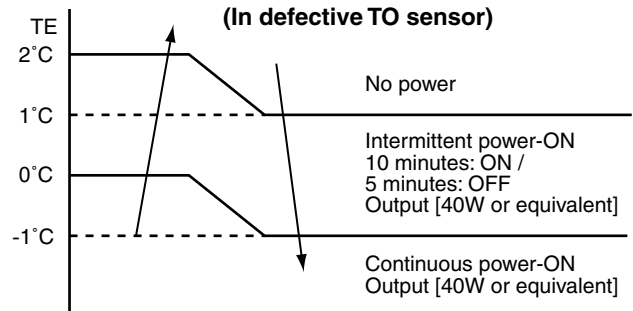

REQUIREMENT

While heating the coil, the power sound may be heard. However it is not a trouble.

5. Short intermittent operation preventive control

- 1) For 3 to 10 minutes after operation start, in some cases, the compressor does not stop to protect the compressor even if receiving the THERMO OFF signal from indoor.
However it is not abnormal status. (The operation continuance differs according to the operation status.)
- 2) When the operation stops by the remote controller, the operation does not continue.

6. Current release control

No. of revolutions of the compressor is controlled by AC current value detected by the outdoor P.C. board so that the input current of the inverter does not exceed the specified value.

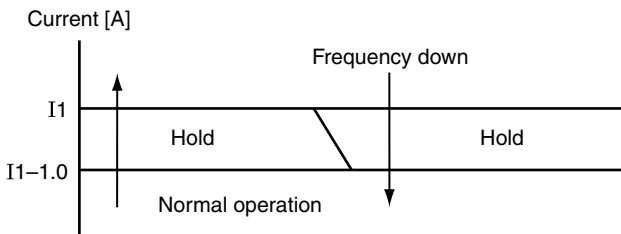

Model	GP56	
	COOL	HEAT
I1 value [A]	12.40	12.40

7. Current release value shift control

- 1) This control purposes to prevent troubles of the electronic parts such as the compressor driving elements and the compressor during cooling operation.
- 2) The current release control value (I1) is selected from the following table according to TO sensor value.

Current release control value (I1)
[A]

Temperature range	GP56
50°C ≤ TO	9.6
45°C ≤ TO < 50°C	10.0
39°C ≤ TO < 45°C	11.6
TO < 39°C	12.4
TO error	9.6

8. Over-current protective control

- 1) When the over-current protective circuit detected an abnormal current, stop the compressor.
- 2) The compressor restarts after 2 minutes 30 seconds as setting [1] as an error count.
- 3) When the error count [8] was found, determine an error and restart operation is not performed.
- 4) For the error display contents, confirm on the check code list.

9. High-pressure release control

- 1) The operation frequency is controlled to restrain abnormal rising of high pressure by TL sensor in cooling operation and TC sensor in heating operation.
- 2) When TL sensor in cooling operation or TC sensor in heating operation detects abnormal temperature of the stop zone, stop the compressor and the error count becomes +1.
- 3) When the compressor stopped with 2), the operation restarts from the point of the normal operation zone (e point or lower) where it returned after 2 minutes 30 seconds.
- 4) The error count when the compressor stopped with 2) is cleared after the operation continued for 10 minutes.
If the error count becomes [10] without clearing, the error is determined and reactivation is not performed.
- 5) For the error display contents, confirm on the check code list.

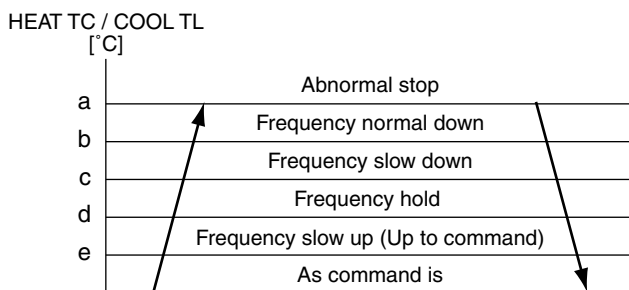

	HEAT	COOL
	TC	TL
a	61°C	61°C
b	54°C	58°C
c	54°C	58°C
d	52°C	56°C
e	48°C	54°C

- 1) In heating operation, defrost operation is performed when TE sensor satisfies any condition in A zone to D zone.
- 2) During defrosting operation, it finishes if TE sensor continued 12°C or higher for 3 seconds or continued 7°C ≤ TE < 12°C for 1 minute. The defrost operation also finishes when it continued for 10 minutes even if TE sensor temperature was 7°C or lower.
- 3) After defrost operation was reset, the compressor stopped for approx. 40 seconds and then the heating operation starts.

Start of heating operation

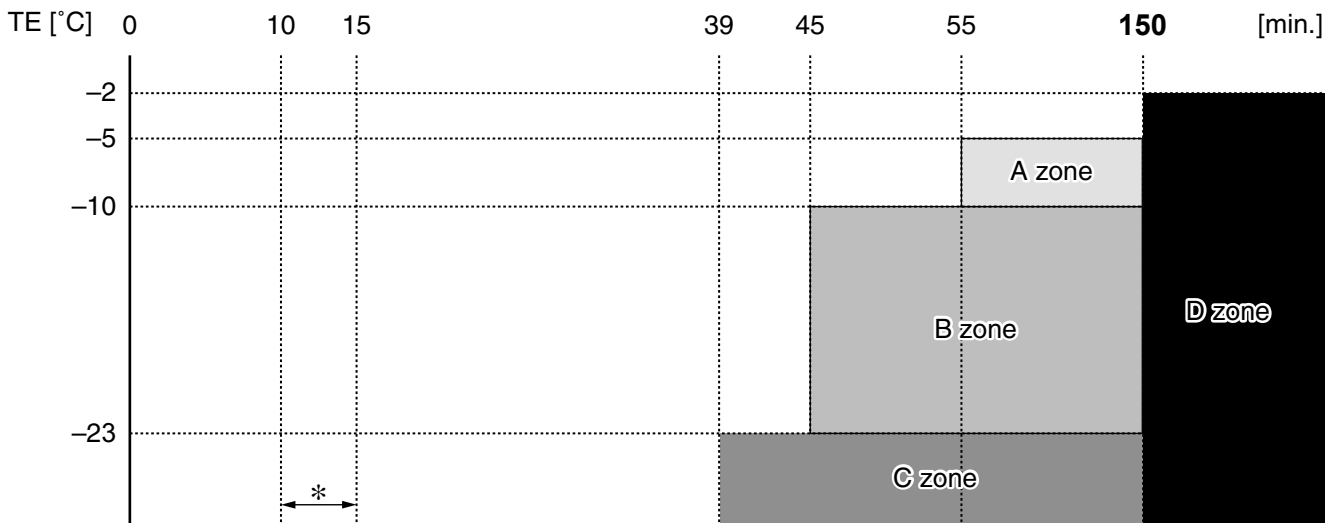

* The minimum TE value and To value between 10 and 15 minutes after heating operation has started are stored in memory as TE0 and To0, respectively.

	In normal To	In abnormal To
A zone	When status $(TE0 - TE) - (To0 - To) \geq 3^\circ\text{C}$ continued for 20 seconds	When status $(TE0 - TE) \geq 3^\circ\text{C}$ continued for 20 seconds
B zone	When status $(TE0 - TE) - (To0 - To) \geq 2^\circ\text{C}$ continued for 20 seconds	When status $(TE0 - TE) \geq 2^\circ\text{C}$ continued for 20 seconds
C zone	When the status $(TE \leq -23^\circ\text{C})$ continued for 20 seconds	
D zone	When compressor operation status of $TE < -2^\circ\text{C}$ is calculated as 150 minutes	

7-2. Outdoor Print Circuit Board

RAV-GP561ATP*

<MCC-1713>

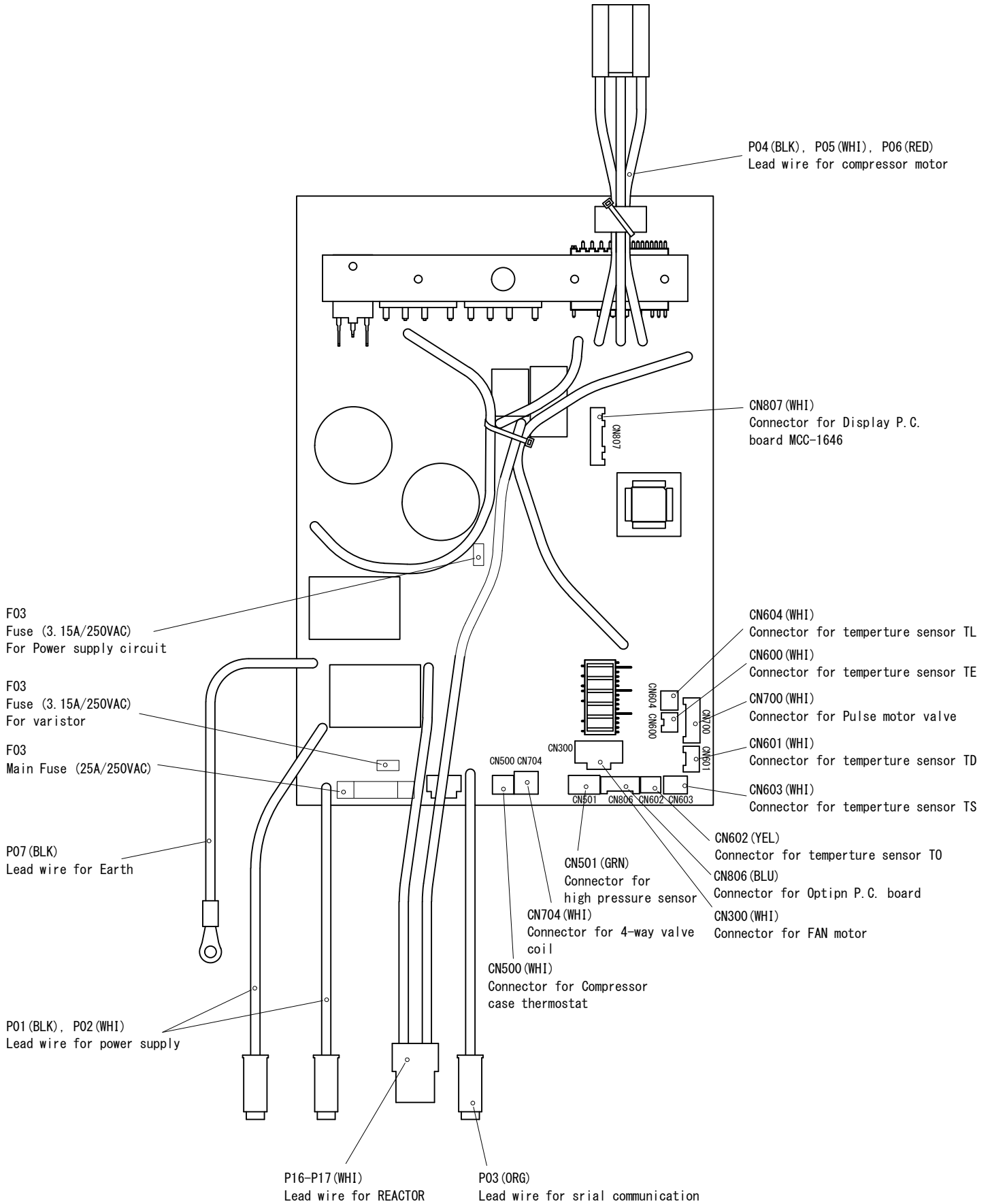

8. TROUBLESHOOTING

8-1. Summary of Troubleshooting

<Wired remote controller type>

1. Before troubleshooting

1) Required tools/instruments

- ⊕ and ⊖ screwdrivers, spanners, radio cutting pliers, nippers, push pins for reset switch
- Tester, thermometer, pressure gauge, etc.

2) Confirmation points before check

a) The following operations are normal.

1. Compressor does not operate.

- Is not 3-minutes delay (3 minutes after compressor OFF)?
- Is not the outdoor unit in standby status though the remote controller reached the setup temperature?
- Does not timer operate during fan operation?
- Is not an overflow error detected on the indoor unit?
- Is not outside high-temperature operation controlled in heating operation?

2. Indoor fan does not rotate.

- Does not cool air discharge preventive control work in heating operation?

3. Outdoor fan does not rotate or air volume changes.

- Does not high-temperature release operation control work in heating operation?
- Does not outside low-temperature operation control work in cooling operation?
- Is not defrost operation performed?

4. ON/OFF operation cannot be performed from remote controller.

- Is not the control operation performed from outside/remote side?
- Is not automatic address being set up?
(When the power is turned on at the first time or when indoor unit address setting is changed, the operation cannot be performed for maximum approx. 5 minutes after power-ON.)
- Is not being carried out a test run by operation of the outdoor controller?

b) Did you return the cabling to the initial positions?

c) Are connecting cables of indoor unit and remote controller correct?

2. Troubleshooting procedure

When a trouble occurred, check the parts along with the following procedure.



NOTE :

For cause of a trouble, power conditions or malfunction/erroneous diagnosis of microcomputer due to outer noise is considered except the items to be checked. If there is any noise source, change the cables of the remote controller to shield cables.

<Wireless remote controller type>**1. Before troubleshooting**

- 1) Required tools/instruments
 - ⊕ and ⊖ screwdrivers, spanners, radio cutting pliers, nippers, etc.
 - Tester, thermometer, pressure gauge, etc.
- 2) Confirmation points before check
 - a) The following operations are normal.
 1. Compressor does not operate.
 - Is not 3-minutes delay (3 minutes after compressor OFF)?
 - Is not the outdoor unit in standby status though the remote controller reached the setup temperature?
 - Does not timer operate during fan operation?
 - Is not an overflow error detected on the indoor unit?
 - Is not outside high-temperature operation controlled in heating operation?
 2. Indoor fan does not rotate.
 - Does not cool air discharge preventive control work in heating operation?
- 3) Outdoor fan does not rotate or air volume changes.
 - Does not high-temperature release operation control work in heating operation?
 - Does not outside low-temperature operation control work in cooling operation?
 - Is not defrost operation performed?
- 4) ON/OFF operation cannot be performed from remote controller.
 - Is not forced operation performed?
 - Is not the control operation performed from outside/remote side?
 - Is not automatic address being set up?
 - Is not being carried out a test run by operation of the outdoor controller?
 - a) Did you return the cabling to the initial positions?
 - b) Are connecting cables between indoor unit and receiving unit correct?

2. Troubleshooting procedure

(When the power is turned on at the first time or when indoor unit address setting is changed, the operation cannot be performed for maximum approx. 5 minutes after power-ON.)

When a trouble occurred, check the parts along with the following procedure.

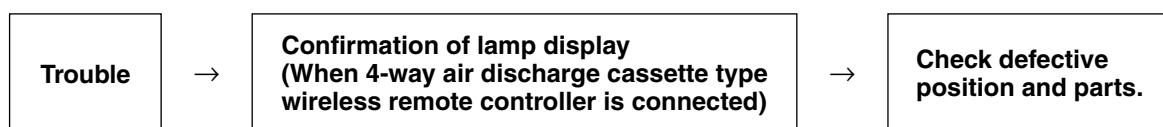

1) Outline of judgment

The primary judgment to check where a trouble occurred in indoor unit or outdoor unit is performed with the following method.

Method to judge the erroneous position by flashing indication on the display part of indoor unit (sensors of the receiving unit)

The indoor unit monitors operating status of the air conditioner, and the blocked contents of self-diagnosis are displayed restricted to the following cases if a protective circuit works.

8-2. Troubleshooting

8-2-1. Outline of judgment

The primary judgment to check whether a trouble occurred in the indoor unit or outdoor unit is carried out with the following method.

Method to judge the erroneous position by flashing indication on the display part of the indoor unit (sensors of the receiving part)

The indoor unit monitors the operating status of the air conditioner, and the blocked contents of self-diagnosis are displayed restricted to the following cases if a protective circuit works.

● : Go off, ○ : Go on, ◉ : Flash (0.5 sec.)





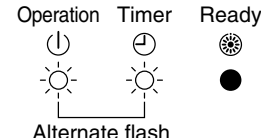
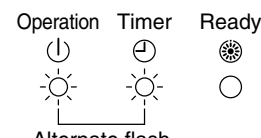
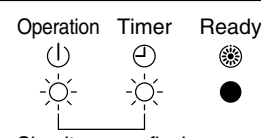
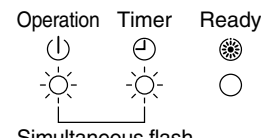
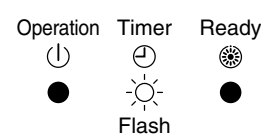
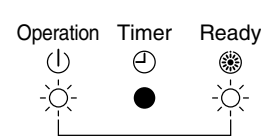
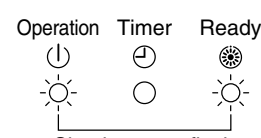







Lamp indication	Check code	Cause of trouble occurrence	
Operation Timer Ready ● ● ● No indication at all	—	Power supply OFF or miswiring between receiving unit and indoor unit	
Operation Timer Ready ● ● ● Flash	E01	Receiving error } Receiving unit } Sending error } Miswiring or wire connection error between receiving unit and indoor unit	
	E02		
	E03		Communication stop
	Operation Timer Ready ◉ ● ● Flash	E08	Duplicated indoor unit No. } Duplicated master units of remote controller } Setup error
		E09	
		E10	Communication error between CPUs on indoor unit P.C. board
Operation Timer Ready ● ● ◉ Flash	E04	Miswiring between indoor unit and outdoor unit or connection error (Communication stop between indoor and outdoor units) Trouble of the outdoor P.C. board. Case thermostat operation.	
	P10	Overflow was detected. } Indoor DC fan error } Protective device of indoor unit worked.	
P12			
Operation Timer Ready ◉ ● ◉ Alternate flash	P03	Outdoor unit discharge temp. error } Outdoor high pressure system error } Protective device of outdoor unit worked. *1	
	P04		
	Operation Timer Ready ◉ ● ◉ Alternate flash	P05	Power supply voltage error } Heat sink overheat error } Outdoor unit error Gas leak detection error }
		P07	
		P15	
	P19	4-way valve system error (Indoor or outdoor unit judged.)	
	P20	Outdoor unit high pressure protection	
	Operation Timer Ready ◉ ● ◉ Alternate flash	P22	Outdoor fan system error } Short-circuit error of compressor driving device } Protective device of outdoor unit worked. *1 Position detection circuit error }
		P26	
		P29	
P31	Stopped because of error of other indoor unit in a group (Check codes of E03/L03/L07/L08)		

*1: These are representative examples and the check code differs according to the outdoor unit to be combined.

Lamp indication	Check code	Cause of trouble occurrence
Operation Timer Ready 	F01	Heat exchanger sensor (TCJ) error } Indoor unit sensor error Heat exchanger sensor (TC) error } Heat exchanger sensor (TA) error }
	F02	
	P10	
Operation Timer Ready 	F04	Discharge temp. sensor (TD) error } Sensor error of outdoor unit *1 Temp. sensor (TE) error } Temp. sensor (TL) error } Temp. sensor (TO) error } Temp. sensor (TS) error } Temp. sensor (TH) error } Temp. sensor miswiring (TE, TS) }
	F06	
	F07	
	F08	
	F12	
	F13	
	F15	
Operation Timer Ready 	F29	Indoor EEPROM error
Operation Timer Ready 	F31	Outdoor EEPROM error
Operation Timer Ready 	H01	Compressor break down } Outdoor compressor system error *1 Compressor lock } Current detection circuit error } Case thermostat worked. }
	H02	
	H03	
	H04	
Operation Timer Ready 	L03	Duplicated master indoor units } There is indoor unit of group connection } → AUTO address in individual indoor unit. } * If group construction and Unsetting of group address } address are not normal Missed setting } when power supply turned on, (Unset indoor capacity) } automatically goes to address setup mode.
	L07	
	L08	
	L09	
Operation Timer Ready 	L10	Unset model type (Service board) } Others Duplicated indoor central addresses } Other error of outdoor unit } Outside interlock error }
	L20	
	L29	
	L30	

*1: These are representative examples and the check code differs according to the outdoor unit to be combined.

8-2-2. Others (Other than Check Code)

Lamp indication	Check code	Cause of trouble occurrence
<p>Operation Timer Ready</p> <p>  </p> <p>  </p> <p>Simultaneous flash</p>	<p>—</p>	<p>During test run</p>
<p>Operation Timer Ready</p> <p>  </p> <p>  </p> <p>Alternate flash</p>	<p>—</p>	<p>Disagreement of cool/heat (Automatic cool/heat setting to automatic cool/heat prohibited model, or setting of heating to cooling-only model)</p>

8-2-4. Check Code List (Outdoor)

ALT (Alternate): Alternate flashing when there are two flashing LED SIM (Simultaneous): Simultaneous flashing when there are two flashing LED
 (◐ on, ◑ : Flash, ● : Go off

Remote controller indication	Sensor lamp part		Representative defective position	Detection	Explanation of trouble contents	Automatic reset	Operation continuation
	Block indication	Ready					
F04	◑	◑	Outdoor unit Discharge temp. sensor (TD) trouble	Outdoor	Open/Short of discharge temp. sensor was detected.	X	X
F06	◑	◑	Outdoor unit Temp. sensor (TE, TS, TL) trouble	Outdoor	Open/Short of heat exchanger temp. sensor was detected. Miswiring between TE sensor and TS sensor	X	X
F08	◑	◑	Outdoor unit Outside temp. sensor (TO) trouble	Outdoor	Open/Short of outside temp. sensor was detected.	○	○
F07	◑	◑	Outdoor unit Temp. sensor (TL) trouble	Outdoor	Open/Short of heat exchanger temp. sensor was detected.	X	X
F12	◑	◑	Outdoor unit Temp. sensor (TS) trouble	Outdoor	Open/Short of suction temp. sensor was detected.	X	X
F13	◑	◑	Outdoor unit Temp. sensor (TH) trouble	Outdoor	Open/Short of heat sink temp. sensor (Board installed) was detected.	X	X
F15	◑	◑	Outdoor unit Misconnection of temp. sensor (TE, TS)	Outdoor	Misconnection of outdoor heat exchanger temp. sensor and suction temp. sensor was detected.	X	X
F31	◑	◑	Outdoor unit EEPROM trouble	Outdoor	Outdoor P.C. board part (EEPROM) trouble was detected.	X	X
H01	●	●	Outdoor unit Compressor break down	Outdoor	When reached min-Hz by current release control, short-circuited current (Idc) after DC excitation was detected.	X	X
H02	●	●	Outdoor unit Compressor lock	Outdoor	Compressor lock was detected.	X	X
H03	●	●	Outdoor unit Current detection circuit trouble	Outdoor	Current detection circuit trouble	X	X
H04	●	●	Outdoor unit Case thermostat operation	Outdoor	Case thermostat operation was detected.	X	X
L10	◑	◑	Outdoor unit Setting trouble of service P.C. board type	Outdoor	When outdoor service P.C. board was used, model type select jumper setting was inappropriate.	X	X
L29	◑	◑	Outdoor unit Other outdoor unit trouble	Outdoor	1) Defective parts on outdoor P.C. board (MCU communication, EEPROM, TH sensor trouble) 2) When outdoor service P.C. board was used, model type selection was inappropriate. 3) Other trouble (Heat sink abnormal overheat, gas leak, 4-way valve inverse trouble) was detected.	X	X
P03	◑	◑	Outdoor unit Discharge temp. trouble	Outdoor	Trouble was detected by discharge temp. release control.	X	X
P04	◑	◑	Outdoor unit High pressure system trouble, Power supply voltage trouble	Outdoor	When case thermostat worked, trouble was detected by high release control from indoor/outdoor heat exchanger temp. sensor. Power supply voltage trouble	X	X
P05	◑	◑	Power supply trouble	Outdoor	Power supply voltage trouble	X	X
P07	◑	◑	Outdoor unit Heat sink overheat	Outdoor	Abnormal overheat was detected by outdoor heat sink temp. sensor.	X	X
P15	◑	◑	Gas leak detection	Outdoor	Abnormal overheat of discharge temp. or suction temp. was detected.	X	X
P20	◑	◑	Outdoor unit High pressure system trouble	Outdoor	Trouble was detected by high release control from indoor/outdoor heat exchanger temp. sensor.	X	X
P22	◑	◑	Outdoor unit Outdoor fan trouble	Outdoor	Trouble (Over-current, lock, etc.) was detected on outdoor fan drive circuit.	X	X
P26	◑	◑	Outdoor unit Inverter Idc operation	Outdoor	Short-circuited protective operation of compressor drive circuit element (G-Tr /IGBT) worked.	X	X
P29	◑	◑	Outdoor unit Position detection trouble	Outdoor	Position detection trouble of compressor motor was detected.	X	X
E01	◑	●	No remote controller header unit Remote controller communication trouble	Remote controller	Signal was not received from indoor unit Main remote controller was not set. (including 2 remote controllers)	—	—
E02	◑	●	Remote controller send trouble	Remote controller	Signal cannot be sent to indoor unit.	—	—
E03	◑	●	Regular communication trouble between indoor and remote controller	Indoor	No communication from remote controller and network adapter	○	X
E04	●	◑	Indoor/Outdoor serial trouble	Indoor	Serial communication trouble between indoor and outdoor, trouble of the outdoor P.C. board or case thermostat operation.	○	X
E08	◑	●	Duplicated indoor addresses	Indoor	Same address as yours was detected.	○	○
E09	◑	●	Duplicated main remote controllers	Remote controller	In 2-remote controller control, both were set as header. (Indoor header unit stops warning and follower unit continues operation.)	X	X
E10	◑	●	Communication trouble between CPU and follower indoor units	Indoor	MCU communication trouble between main motor and micro computer	○	△
E18	◑	●	Regular communication trouble between header and follower indoor units	Indoor	Regular communication was impossible between header and follower indoor units. Communication between twin header (Main unit) and follower (sub unit) was impossible.	○	X
L03	◑	●	Duplicated indoor header units	Indoor	There are multiple header units in a group.	X	X
L07	◑	●	There is group cable in individual indoor unit.	Indoor	When even one group connection indoor unit exists in individual indoor unit.	X	X
L08	◑	●	Unset indoor group address	Indoor	Indoor address group was unset.	X	X
L09	◑	●	Unset indoor capacity	Indoor	Capacity of indoor unit was unset.	X	X
L30	◑	◑	Outside trouble input to indoor unit (Interlock)	Indoor	Abnormal stop by CN80 outside trouble input	X	X
P19	◑	●	4-way valve inverse trouble	Indoor Outdoor	In heating operation, trouble was detected by temp. down of indoor heat exchanger or temp. up of TE, TS.	○	X

◇ When this warning was detected before group construction/address check finish at power supply was turned on, the mode shifts automatically to AUTO address setup mode.

○:Go on, ◎: Flash, ●: Go off
 ALT (Alternate): Alternate flashing when there are two flashing LED SIM (Simultaneous): Simultaneous flashing when there are two flashing LED

Remote controller indication	Sensor lamp part		Representative defective position	Detection	Explanation of trouble contents	Automatic reset	Operation continuation
	Block indication	Ready					
F01	◎	◎	Indoor unit Heat exchanger sensor (TC ₁) trouble	Indoor	Open/Short of heat exchanger (TC ₁) was detected.	○	×
F02	◎	◎	Indoor unit Heat exchanger sensor (TC) trouble	Indoor	Open/Short of heat exchanger (TC) was detected.	○	×
F10	◎	◎	Indoor unit Room temp. sensor (TA) trouble	Indoor	Open/Short of room temp. (TA) was detected.	○	×
F29	◎	◎	Indoor unit Other indoor P.C.-board trouble	Indoor	EEPROM trouble (Other trouble may be detected. If no trouble, automatic address is repeated.)	×	×
P01	●	◎	Indoor unit Indoor fan trouble	Indoor	Indoor AC fan trouble was detected. (Fan thermal relay worked.)	×	×
P10	●	◎	Indoor unit Overflow detection	Indoor	Float switch worked.	×	×
P12	●	◎	Indoor unit Indoor fan trouble	Indoor	Indoor fan trouble (Over-current / Lock etc.) was detected.	×	×
P31	◎	◎	Other indoor unit trouble	Indoor	Other indoor under condition of warning in group. E03/L07/L03/L08 warning	○	×
—	By unit with warning No.		Trouble in indoor group	Network adapter	Sub remote controller trouble in a group (Details of remote controller are displayed with unit No. Only central control side is displayed.)	—	—
—	—	—	LAN system communication trouble	Network adapter/ Center	Communication trouble of central control system signal * Is not displayed on the remote controller	○	○
L20	◎	○	LAN system communication trouble	Network adapter/ Center	Duplicated indoor address of central control system communication	○	×
—	—	—	There are multiple communication adapters.	Network adapter	There are multiple communication adapters on remote controller communication line.	○	○

Failure mode detected by indoor unit

Operation of diagnostic function				Judgment and measures
Check code	Cause of operation	Status of air conditioner	Condition	
E03	No communication from remote controller (including wireless) and communication adapter	Stop (Automatic reset)	Displayed when trouble is detected	1. Check cables of remote controller and communication adapters. • Remote controller LCD display OFF (Disconnection) • Central remote controller [97] check code
E04	The serial signal is not output from outdoor unit to indoor unit. • Miswiring of inter-unit wire • Defective serial sending circuit on outdoor P.C. board • Defective serial receiving circuit on indoor P.C. board	Stop (Automatic reset)	Displayed when trouble is detected	1. Outdoor unit does not completely operate. • Inter-unit wire check, correction of miswiring • Check case thermostat and connector. • Check outdoor P.C. board. Correct wiring of P.C. board. 2. When outdoor unit normally operates Check P.C. board (Indoor receiving / Outdoor sending).
E08	Duplicated indoor unit address	Stop	Displayed when trouble is detected	1. Check whether remote controller connection (Group/Individual) was changed or not after power supply turned on (Finish of group construction/Address check). * If group construction and address are not normal when the power has been turned on, the mode automatically shifts to address setup mode. (Resetting of address)
L03	Duplicated indoor header unit			
L07	There is group wire in individual indoor unit.			
L08	Unset indoor group address			
L09	Unset indoor capacity	Stop	Displayed when trouble is detected	1. Set indoor capacity (DN=11)
L30	Abnormal input of outside interlock	Stop	Displayed when trouble is detected	1. Check outside devices. 2. Check indoor P.C. board.
P10	Float switch operation • Float circuit, Disconnection, Coming-off, Float switch contact trouble	Stop	Displayed when trouble is detected	1. Trouble of drain pump 2. Clogging of drain pump 3. Check float switch. 4. Check indoor P.C. board.
P12	Indoor DC fan trouble	Stop	Displayed when trouble is detected	1. Position detection trouble 2. Over-current protective circuit of indoor fan driving unit operated. 3. Indoor fan locked. 4. Check indoor P.C. board.
P19	4-way valve system trouble • After heating operation has started, indoor heat exchangers temp. is down.	Stop (Automatic reset)	Displayed when trouble is detected	1. Check 4-way valve. 2. Check 2-way valve and check valve. 3. Check indoor heat exchanger (TC/TCJ). 4. Check indoor P.C. board.
P31	Own unit stops while warning is output to other indoor units.	Stop (Follower unit) (Automatic reset)	Displayed when trouble is detected	1. Judge follower unit while header unit is [E03], [L03], [L07] or [L08]. 2. Check indoor P.C. board.
F01	Coming-off, disconnection or short of indoor heat exchanger temp. sensor (TCJ)	Stop (Automatic reset)	Displayed when trouble is detected	1. Check indoor heat exchanger temp. sensor (TCJ). 2. Check indoor P.C. board.
F02	Coming-off, disconnection or short of indoor heat exchanger temp. sensor (TC)	Stop (Automatic reset)	Displayed when trouble is detected	1. Check indoor heat exchanger temp. sensor (TC). 2. Check indoor P.C. board.
F10	Coming-off, disconnection or short of indoor heat exchanger temp. sensor (TA)	Stop (Automatic reset)	Displayed when trouble is detected	1. Check indoor heat exchanger temp. sensor (TA). 2. Check indoor P.C. board.
F29	Indoor EEPROM trouble • EEPROM access trouble	Stop (Automatic reset)	Displayed when trouble is detected	1. Check indoor EEPROM. (including socket insertion) 2. Check indoor P.C. board.
E10	Communication trouble between indoor MCU • Communication trouble between fan driving MCU and main MCU	Stop (Automatic reset)	Displayed when trouble is detected	1. Check indoor P.C. board.
E18	Regular communication trouble between indoor aster and follower units and between main and sub units	Stop (Automatic reset)	Displayed when trouble is detected	1. Check remote controller wiring. 2. Check indoor power supply wiring. 3. Check indoor P.C. board.

Failure mode detected by outdoor unit

Operation of diagnostic function				Judgment and measures
Check code	Cause of operation	Status of air conditioner	Condition	
Indoor unit				
F04	Disconnection, short of discharge temp. sensor (TD)	Stop	Displayed when trouble is detected	1. Check discharge temp. sensor (TD). 2. Check outdoor P.C. board.
F06	Disconnection, short of outdoor temp. sensor (TE)	Stop	Displayed when trouble is detected	1. Check temp. sensor (TE). 2. Check outdoor P.C. board.
F07	Disconnection, short of outdoor temp. sensor (TL)	Stop	Displayed when trouble is detected	1. Check temp. sensor (TL). 2. Check outdoor P.C. board.
F12	Disconnection, short of suction temp. sensor (TS)	Stop	Displayed when trouble is detected	1. Check suction temp. sensor (TS). 2. Check outdoor P.C. board.
F15	Miss-mounting of outdoor temp. sensor (TE, TS)	Stop	Displayed when trouble is detected	1. Check temp. sensor (TE, TS). 2. Check outdoor P.C. board.
F08	Disconnection, short of outside temp. sensor (TO)	Continue	Displayed when trouble is detected	1. Check outside temp. sensor (TO). 2. Check outdoor P.C. board.
F13	Disconnection, short of heat sink temp. sensor (TH)	Stop	Displayed when trouble is detected	1. Check outdoor P.C. board. (R612 is in TH sensor.)
F31	Outdoor P.C. EEPROM trouble	Stop	Displayed when trouble is detected	1. Check outdoor P.C. board.
L10	Unset jumper of service P.C. board	Stop	Displayed when trouble is detected	1. Outdoor service P.C. board Check model type setting jumper wire.
L29	Communication trouble between outdoor P.C. board MCU	Stop	Displayed when trouble is detected	1. Check outdoor P.C. board
P07	Heat sink overheat trouble * Heat sink temp. sensor detected over specified temperature.	Stop	Displayed when trouble is detected	1. Check screw tightening between PC. Board and heat sink and check radiator grease. 2. Check heat sink blast path.
P15	Detection of gas leak * Discharge temp. sensor (TD), Suction temp. sensor (TS) detected temperature over specified temp.	Stop	Displayed when trouble is detected	1. Check gas leak, recharge 2. Check full open of service valve. 3. Check PMV (Pulse Motor Valve). 4. Check broken pipe. 5. Check discharge temp. sensor (TD), suction temp. sensor (TS).
P19	4-way valve inverse trouble * After heating operation has started, indoor heat exchanger temp. lowers under the specified temp. * After heating operation has started, outdoor heat exchanger / suction temp. rises over the specified temp.	Stop	Displayed when trouble is detected	1. Check operation of 4-way valve. 2. Check outdoor heat exchanger (TE), suction temp. sensor (TS). 3. Check indoor heat exchanger sensor (TC). 4. Check 4-way valve coil. 5. Check PMV (Pulse Motor Valve).
H01	Compressor break down * Although operation has started, operation frequency decreases and operation stops.	Stop	Displayed when trouble is detected	1. Check power supply voltage. (AC198 to 264V) 2. Overload operation of refrigerating cycle
H02	Compressor lock * Over-current detection after compressor start-up	Stop	Displayed when trouble is detected	1. Trouble of compressor (Lock, etc.): Replace compressor. 2. Wiring trouble of compressor (Open phase)
H03	Current detection circuit trouble	Stop	Displayed when trouble is detected	1. Check outdoor P.C. board. (AC current detection circuit)
F23	Ps sensor trouble	Stop	Displayed when trouble is detected	1. Check connection of Ps sensor connector. 2. Check failure of Ps sensor. 3. Check compressing power trouble of compressor. 4. Check 4-way valve trouble. 5. Check outdoor P.C. board trouble.

Operation of diagnostic function				Judgment and measures
Check code	Cause of operation	Status of air conditioner	Condition	
Indoor unit				
P03	Discharge temp. trouble * Discharge temp. (TD) over specified value was detected.	Stop	Displayed when trouble is detected	1. Check refrigerating cycle (Gas leak) 2. Trouble of electronic expansion valve 3. Check discharge temp. sensor (TD).
H04	Case thermostat operation * Abnormal overheat of compressor	Stop	Displayed when trouble is detected	1. Check case thermostat and connector. 2. Check gas leak, recharge 3. Check full open of service valve. 4. Check PMV (Pulse Motor Valve). 5. Check broken pipe.
P04	High pressure SW system trouble	Stop	Displayed when trouble is detected	1. Check service valves are fully opened. (Gas side, Liquid side) 2. Check of outdoor fan operation. 3. Check motor trouble of outdoor fan. 4. Check clogging of outdoor PMV. 5. Check clogging of heat exchanger in indoor/outdoor units. 6. Short-circuit status of suction/discharge air in outdoor unit. 7. Check outdoor P.C. board trouble. 8. Check fan system trouble (Cause of air volume drop) at indoor side. 9. Check PMV opening status in indoor unit.
P05	Power supply voltage trouble	Stop	Displayed when trouble is detected	1. Check power supply voltage. AC198 to 264V
	High pressure SW system trouble	Stop	Displayed when trouble is detected	1. Check service valves are fully opened. (Gas side, Liquid side) 2. Check of outdoor fan operation. 3. Check motor trouble of outdoor fan. 4. Check clogging of outdoor PMV. 5. Check clogging of heat exchanger in indoor/outdoor units. 6. Short-circuit status of suction/discharge air in outdoor unit. 7. Check outdoor P.C. board trouble. 8. Check fan system trouble (Cause of air volume drop) at indoor side. 9. Check PMV opening status in indoor unit.
P20	High pressure protective operation * During cooling operation, outdoor temp. sensor (TL) detected temperature over specified temp. * During heating operation, indoor temp. sensor (TC, TCJ) detected temperature over specified temp.	Stop	Displayed when trouble is detected	1. Check outdoor heat exchanger sensor (TL). 2. Check indoor heat exchanger sensor (TC, TCJ). 3. Check full open of service valve. 4. Check indoor/outdoor fan. 5. Check PMV (Pulse Motor Valve). 6. Check clogging and short circuit of indoor/outdoor heat exchanger. 7. Overcharge of refrigerant. Recharge
P22	Outdoor fan system trouble	Stop	Displayed when trouble is detected	1. Check lock of fan motor. 2. Check outdoor P.C. board.
P26	Short-circuit trouble of compressor driving element	Stop	Displayed when trouble is detected	1. When performing operation while taking-off compressor wire, P26 trouble occurs. Check control P.C. board. 2. When performing operation while taking-off compressor wire, a trouble does not occur. (Compressor rare short)
P29	Position detection circuit trouble	Stop	Displayed when trouble is detected	1. Check control P.C. board.

Failure mode detected by remote controller or central controller (TCC-LINK)

Operation of diagnostic function				Judgment and measures
Check code	Cause of operation	Status of air conditioner	Condition	
Not displayed at all (Operation on remote controller is impossible.)	No communication with header indoor unit <ul style="list-style-type: none"> Remote controller wiring is not correct. Power of indoor unit is not turned on. Automatic address cannot be completed. 	Stop	—	Power supply trouble of remote controller, Indoor EEPROM trouble <ol style="list-style-type: none"> 1. Check remote controller inter-unit wiring. 2. Check remote controller. 3. Check indoor power wiring. 4. Check indoor P.C. board. 5. Check indoor EEPROM. (including socket insertion) → Automatic address repeating phenomenon generates.
E01 *2	No communication with header indoor unit <ul style="list-style-type: none"> Disconnection of inter-unit wire between remote controller and header indoor unit (Detected by remote controller side) 	Stop (Automatic reset) * If center exists, operation continues.	Displayed when trouble is detected	Receiving trouble from remote controller <ol style="list-style-type: none"> 1. Check remote controller inter-unit wiring. 2. Check remote controller. 3. Check indoor power wiring. 4. Check indoor P.C. board.
E02	Signal send trouble to indoor unit (Detected by remote controller side)	Stop (Automatic reset) * If center exists, operation continues.	Displayed when trouble is detected	Sending trouble of remote controller <ol style="list-style-type: none"> 1. Check sending circuit inside of remote controller. → Replace remote controller.
E09	There are multiple main remote controllers. (Detected by remote controller side)	Stop (Sub unit continues operation.)	Displayed when trouble is detected	1. In 2-remote controllers (including wireless), there are multiple main units. Check that there are 1 main remote controller and other sub remote controllers.
L20 ----- Central controller L20	Duplicated indoor central addresses on communication of central control system (Detected by indoor/central controller side)	Stop (Automatic reset)	Displayed when trouble is detected	1. Check setting of central control system network address. (Network adapter SW01) 2. Check network adapter P.C. board.
— *3 ----- Central controller (Send) C05 (Receive) C06	Communication circuit trouble of central control system (Detected by central controller side)	Continues (By remote controller)	Displayed when trouble is detected	1. Check communication wire / miswiring 2. Check communication (U3, U4 terminals) 3. Check network adapter P.C. board. 4. Check central controller (such as central control remote controller, etc.) 5. Check terminal resistance. (TCC-LINK)
— ----- Central controller P30	Indoor Gr sub unit trouble (Detected by central controller side)	Continuation/Stop (According to each case)	Displayed when trouble is detected	Check the check code of the corresponding unit from remote controller.

*2 The check code cannot be displayed by the wired remote controller.
(Usual operation of air conditioner becomes unavailable.)

For the wireless models, a trouble is notified with indication lamp.

*3 This trouble is related to communication of remote controller (A, B), central system (TCC-LINK U3, U4), and [E01], [E02], [E03], [E09] or [E18] is displayed or no check display on the remote controller according to the contents.

8-2-5. Diagnostic Procedure for Each Check Code (Outdoor Unit)

- 1) This section describes the diagnostic method for each check code displayed on the wired remote controller.
- 2) In some cases, a check code indicates multiple symptoms.
In this case, confirm LED display on the outdoor P.C. board to narrow the contents to be confirmed.
- 3) The check code on the remote controller is displayed only when the same trouble occurred continuously by multiple times while LED of the outdoor P.C. board displays even an trouble which occurred once.
Therefore the display on the remote controller may differ from that of LED.

How to check LED display on the outdoor P.C. board

[Service switch operation]

Currently occurring trouble indication

Even if only one of D800 to D804 is rapidly flashing then trouble has arisen. If any of D800 to D801 is slowly flashing or D805 is flashing then press and hold down SW01 and SW02 at the same time for at least 5 seconds.

D800 (YEL)	D801 (YEL)	D802 (YEL)	D803 (YEL)	D804 (YEL)	D805 (GRN)	
●	●	●	●	●	○	No trouble
◎	●	●	●	●	○	Trouble detected (Example. Discharge temp. trouble)

● : Go OFF ○ : Go ON ◎ : Flash (5 times/sec)

Latest trouble indication







- The following operation results in the latest trouble being indicated. It is retained in the memory and hence can be confirmed even when the power supply has been turned off. (Excluding outside air temperature sensor (TO) trouble)
 - 1) Confirm D800 to D804 are off (or rapidly flashing) and that D805 is lit up. If D800 to D804 are slowly flashing or D805 is flashing then push and hold down SW01 and SW02 at the same time for at least 5 seconds. D800 to D804 will turn off (or be rapidly flashing) and D805 will change to flashing.
 - 2) Push and hold down SW01 for at least 5 seconds. D804 will start slowly flashing.
 - 3) Push SW01 several times until reaching the LED indication (D800 to D804) of 'Latest (including current) trouble indication'.
 - 4) Push SW02. The latest trouble will be indicated.
 - 5) Ensure to carry out step 1) to set the LEDs to the initial state (current occurring trouble) when finished and then exit.

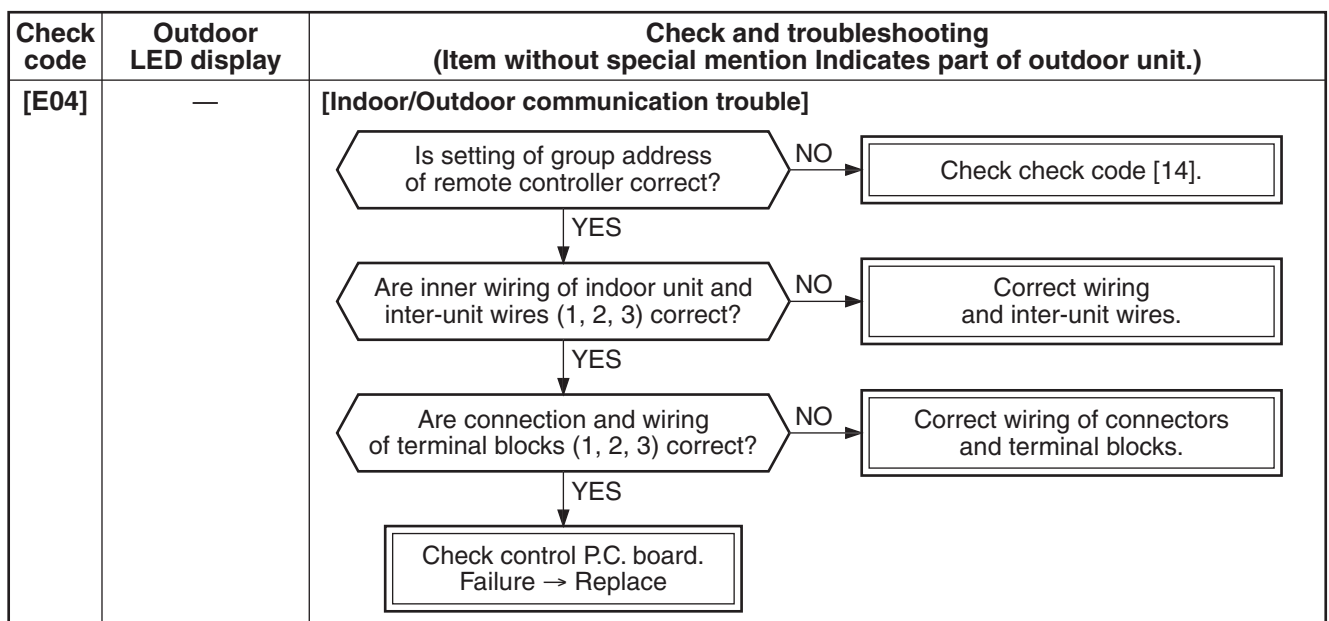

Latest (including current) trouble indication

D800 (YEL)	D801 (YEL)	D802 (YEL)	D803 (YEL)	D804 (YEL)	D805 (GRN)
○	●	●	●	●	◎

● : Go OFF ○ : Go ON ◎ : Flash (5 times/sec)



Check code	Outdoor LED display	Check and troubleshooting (Item without special mention indicates part of outdoor unit.)
[F04]		<p>[Discharge temp. sensor (TD) trouble]</p> <p>Is connection of CN601 correct? Is resistance value of TD sensor correct?</p> <p>NO → Correct connector. Replace TD sensor</p> <p>YES → Check outdoor P.C. board. Failure → Replace</p>
[F06]		<p>[Heat exchanger temp. sensor (TE) trouble]</p> <p>Is connection of CN600 correct? Is resistance value of TE sensor correct?</p> <p>NO → Correct connector. Replace TE sensor</p> <p>YES → Check outdoor P.C. board. Failure → Replace</p>
[F07]		<p>[Heat exchanger temp. sensor (TL) trouble]</p> <p>Is connection of CN604 correct? Is resistance value of TL sensor correct?</p> <p>NO → Correct connector. Replace TL sensor</p> <p>YES → Check outdoor P.C. board. Failure → Replace</p>
[F08]		<p>[Outside temp. sensor (TO) trouble]</p> <p>Is connection of CN602 correct? Is resistance value of TO sensor correct?</p> <p>NO → Correct connector. Replace TO sensor</p> <p>YES → Check outdoor P.C. board. Failure → Replace</p>
[F12]		<p>[Suction temp. sensor (TS) trouble]</p> <p>Is connection of CN603 correct? Is resistance value of TS sensor correct?</p> <p>NO → Correct connector. Replace TS sensor</p> <p>YES → Check outdoor P.C. board. Failure → Replace</p>
[F13]		<p>[Heat sink temp. sensor (TH) trouble]</p> <p>Check outdoor P.C. board. Failure → Replace</p> <p>* When replacing outdoor P.C. board, replace the fuse.</p>

Check code	Outdoor LED display	Check and troubleshooting (Item without special mention Indicates part of outdoor unit.)
[F15]		<p>[Miswiring of heat exchanger sensor (TE, TS)]</p> <pre> graph TD Q1{{Is mounting status of TE and TS sensors correct?}} -- NO --> A1[Correct sensor mounting.] Q1 -- YES --> Q2{{Is connection of CN603 correct? Is resistance value of TS sensor correct?}} Q2 -- NO --> A2[Correct connector. Replace TS sensor] Q2 -- YES --> Q3{{Is connection of CN600 correct? Is resistance value of TE sensor correct?}} Q3 -- NO --> A3[Correct connector. Replace TE sensor] Q3 -- YES --> A4[Check outdoor P.C. board. Failure -> Replace] </pre>
[F31]		<p>[EEPROM trouble]</p> <pre> graph TD A[Check outdoor P.C. board. Failure -> Replace] </pre>
[H01]		<p>[Compressor break down]</p> <pre> graph TD Q1{{Is power supply voltage normal? AC198 to 264V}} -- NO --> A1[Correct power supply line.] Q1 -- YES --> Q2{{Is wire connection correct? Compressor lead (P.C. board side, Compressor side), Reactor lead, Power supply lead}} Q2 -- NO --> A2[Check wire connection and correct it.] Q2 -- YES --> Q3{{Does an abnormal overload happen?}} Q3 -- NO --> A3[Remove and improve the cause of overload.] Q3 -- YES --> A4[Check outdoor P.C. board. Failure -> Replace. * When replacing outdoor P.C.board, replace the fuse.] </pre>

Check code	Outdoor LED display	Check and troubleshooting (Item without special mention Indicates part of outdoor unit.)
[H02]	●●○○●○	<p>[Compressor lock]</p> <pre> graph TD Q1{{Is power supply voltage normal? AC198 to 264V}} -- NO --> A1[Correct power supply line.] Q1 -- YES --> Q2{{Is wire connection correct? Compressor lead (P.C. board side, Compressor side), Reactor lead, Power supply lead}} Q2 -- NO --> A2[Check wire connection and correct it.] Q2 -- YES --> Q3{{Is compressor under correct conditions?}} Q3 -- YES --> A3[Check outdoor P.C. board. Failure -> Replace * When replacing outdoor P.C.board, replace the fuse.] Q3 -- NO --> Q4{{Is there refrigerant stagnation?}} Q4 -- NO --> A4[Compressor lock -> Replace] Q4 -- YES --> Q5{{Does PMV correctly operate?}} Q5 -- NO --> A5[Check TE, TS sensors and PMV. Failure -> Replace] Q5 -- YES --> A3 </pre>
[H03]	○○●○○●○	<p>[Current detection circuit trouble]</p> <div style="border: 1px solid black; padding: 5px; width: fit-content; margin: 0 auto;"> <p>Check outdoor P.C. board. Failure -> Replace</p> </div>
[H04]	●○○○○●○	<p>[Case thermostat operation]</p> <pre> graph TD Q1{{Are CN500 connection and case thermostat correct?}} -- NO --> A1[Correct connector. Case thermostat trouble -> Replace] Q1 -- YES --> Q2{{When shorting the case thermostat, can you perform the cooling/heating operation?}} Q2 -- NO --> A2[Check outdoor P.C. board. Failure -> Replace * When replacing outdoor P.C.board, replace the fuse.] Q2 -- YES --> Q3{{Is there gas leak? Is there refrigerant shortage?}} Q3 -- YES --> A3[Fault part repair. Recharge refrigerant.] Q3 -- NO --> Q4{{Is service valve fully opened?}} Q4 -- NO --> A4[Open service valve fully.] Q4 -- YES --> Q5{{Is PMV normal?}} Q5 -- NO --> A5[Replace the PMV.] Q5 -- YES --> A6[Check crushed or broken pipe. Fault part repair] </pre>



Check code	Outdoor LED display	Check and troubleshooting (Item without special mention Indicates part of outdoor unit.)
[L10]	●●●●○	<p>[Unset jumper of service P.C. board]</p> <div style="border: 1px solid black; padding: 5px; width: fit-content; margin: 10px auto;"> Cut jumper line according to the explanation sheet packaged with the service P.C. board. </div>
[L29]	○●●●○	<p>[Communication trouble MCUs]</p> <div style="border: 1px solid black; padding: 5px; width: fit-content; margin: 10px auto;"> Check outdoor P.C.board Failure → Replace </div>
[P03]	●○●●○	<p>[Discharge temp. trouble]</p> <pre> graph TD Q1{Is there gas leak? Is there refrigerant shortage?} -- NO --> A1[Fault part repair. Recharge refrigerant.] Q1 -- YES --> Q2{Is PMV normal?} Q2 -- NO --> A2[Replace the PMV.] Q2 -- YES --> Q3{Does an abnormal overload happen?} Q3 -- YES --> A3[Remove and improve the cause of overload.] Q3 -- NO --> Q4{Is connection of CN601 correct? Is resistance value of TD sensor correct?} Q4 -- NO --> A4[Replace TD sensor.] Q4 -- YES --> A5[Check outdoor P.C. board. Failure → Replace] </pre>
[P05]	●●○●○	<p>[Powersupply trouble] Voltage failure</p> <pre> graph TD Q1{Check the same items as [P04] trouble.} --> Q2{Does the supply voltage drop or rise (AC198 to 264V)?} Q2 -- YES --> A1[Confirmation of electrical work etc.] Q2 -- NO --> A2[Check outdoor P.C.board Failure → Replace] </pre>

Check code	Outdoor LED display	Check and troubleshooting (Item without special mention Indicates part of outdoor unit.)
[P07]	●○○●○○○	<p>[Heat sink overheat trouble]</p> <pre> graph TD Q1{{Is there any looseness in the screw stop of the motor drive element IC200 of the outdoor P.C. board, the sub heat sink, and the diode bridge? Are radiation grease properly applied?}} A1[Apply radiation grease to objective, retightening of screw] Q2{{Does something block the ventilation around the heatsink? Does something block air flow from the fan? (Short circuit etc.)}} A2[Remove blocking matter, Short circuit improvement] A3[Check outdoor P.C. board. Failure -> Replace. * When replacing outdoor P.C.board, replace the fuse.] Q1 -- YES --> A1 Q1 -- NO --> Q2 Q2 -- YES --> A3 Q2 -- NO --> A2 </pre>
[P15]	○○○●○○○	<p>[Gas leak detection]</p> <pre> graph TD Q1{{Is there gas leak? Is there refrigerant shortage?}} A1[Fault part repair. Recharge refrigerant.] Q2{{Is PMV normal?}} A2[Replace the PMV.] Q3{{Is service valve fully opened?}} A3[Open service valve fully.] Q4{{Is there crushed pipe?}} A4[Correct and replace piping.] Q5{{Check temp. sensor. TD sensor CN601 TS sensor CN603}} A5[Correct connector. Sensor trouble -> Replace] A6[Check outdoor P.C. board. Failure -> Replace] Q1 -- YES --> A1 Q1 -- NO --> Q2 Q2 -- YES --> Q3 Q2 -- NO --> A2 Q3 -- YES --> Q4 Q3 -- NO --> A3 Q4 -- YES --> A4 Q4 -- NO --> Q5 Q5 -- Trouble --> A5 Q5 -- OK --> A6 </pre>

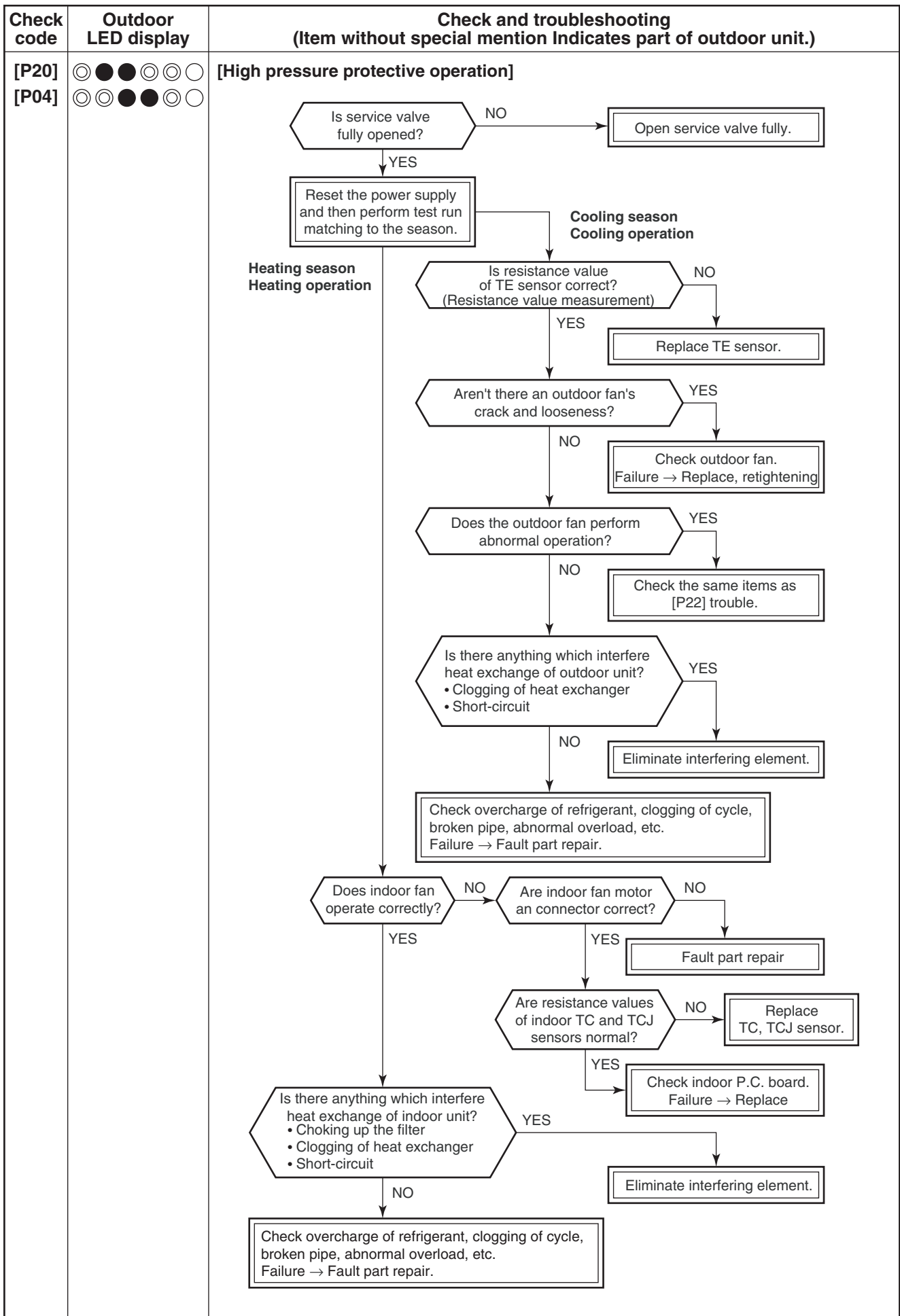
Check code	Outdoor LED display	Check and troubleshooting (Item without special mention indicates part of outdoor unit.)												
[P19]	●●●○○○	<p>[4-way valve inverse trouble]</p> <pre> graph TD Q1{{Does 4-way valve work correctly? (Check pipe temp. etc. in cooling/heating operation.)}} Q2{{Is the coil resistance value of 4-way valve normal?}} Q3{{Temperature sensor normal? TE sensor CN600 TS sensor CN603}} Q4{{Is the flow of the refrigerant by the PMV normal?}} Q5{{Indoor TC, TCJ sensor normal?}} Q6{{The voltage variation due to the confirmation of 4-way valve relay operation, refer to below?}} Q7{{Check outdoor P.C.board}} A1[Replace 4-way valve coil] A2[Replace TE, TS sensor] A3[Check PMV and replace] A4[Replace TC, TCJ sensor] A5[Check indoor P.C.board Failure -> Replace] A6[Check 4-way valve. Defect R Replace] A7[Replace outdoor P.C. board] Q1 -- NO --> Q2 Q1 -- YES --> Q3 Q2 -- NO --> A1 Q2 -- YES --> Q6 Q3 -- NO --> A2 Q3 -- YES --> Q4 Q4 -- NO --> A3 Q4 -- YES --> Q5 Q5 -- NO --> A4 Q5 -- YES --> A5 Q6 -- NG --> A6 Q6 -- OK --> Q7 Q7 -- NG --> A7 Q7 -- OK --> A5 </pre> <p>[4-way valve relay operation check] Service switches SW01 and SW02 can be used to check the operation of the 4-way valve relay. Use to check whether there are any problems with the 4-way valve or 4-way valve coil.</p> <p>[Method of operation]</p> <ol style="list-style-type: none"> 1) Push ensure that D800 to D804 are off (or rapidly flashing) and that D805 is lit up. If D800 to D804 are slowly flashing or D805 is flashing then push and hold down SW01 and SW02 at the same time for at least 5 seconds. D800 to D804 will turn off (or rapidly flash) and D805 turn on. 2) Push and hold down SW01 for at least 5 seconds. D804 will start slowly flashing. 3) Push SW01 until reaching the below [4-way valve resistance value relay operation] LED indication. <table border="1" style="margin-left: auto; margin-right: auto; border-collapse: collapse;"> <tr> <td style="padding: 5px;">4-way valve resistance value relay operation</td> <td style="padding: 5px; text-align: center;">D800</td> <td style="padding: 5px; text-align: center;">D801</td> <td style="padding: 5px; text-align: center;">D802</td> <td style="padding: 5px; text-align: center;">D803</td> <td style="padding: 5px; text-align: center;">D804</td> </tr> <tr> <td style="padding: 5px;"></td> <td style="padding: 5px; text-align: center;">●</td> <td style="padding: 5px; text-align: center;">●</td> <td style="padding: 5px; text-align: center;">○</td> <td style="padding: 5px; text-align: center;">○</td> <td style="padding: 5px; text-align: center;">◎</td> </tr> </table> <p style="text-align: center;">●: Go OFF ○: Go ON ◎: Flash (5 times/sec)</p> <ol style="list-style-type: none"> 4) Push SW02 until D805 starts rapidly flashing. 5) Push and hold down SW02 for at least 5 seconds. D804 will start slowly flashing, D805 will turn on, and the 4-way valve resistance value relay operation will turn on. 6) Push and hold down SW01 and SW02 at the same time for at least 5 seconds or wait 2 minutes to return to normal control. 	4-way valve resistance value relay operation	D800	D801	D802	D803	D804		●	●	○	○	◎
4-way valve resistance value relay operation	D800	D801	D802	D803	D804									
	●	●	○	○	◎									



Check code	Outdoor LED display	Check and troubleshooting (Item without special mention Indicates part of outdoor unit.)												
[P22]	● ○ ● ○ ○ ○ ○	<p>[Fan system trouble]</p> <pre> graph TD Q1{Is power supply voltage normal? AC198 to 264V} -- NO --> A1[Check wiring construction. Ask repair of power supply.] Q1 -- YES --> Q2{Rotate shaft of the fan motor by hands during power-OFF. Can it rotate smoothly? Is coil resistance of fan motor correct? Between red and white lead wire : 12 to 20Ω Between white and black lead wire : 12 to 20Ω Between black and red lead wire : 12 to 20Ω} Q2 -- NO --> A2[Replace fan motor.] Q2 -- YES --> Q3{Is not the fuse (near the terminal block) blows?} Q3 -- NO --> A3[Replace fuse.] Q3 -- YES --> A4[Check outdoor P.C.board Failure → Replace] </pre> <p>[Confirmation of independent operation of outdoor fan] Service switches SW01 and SW02 can be used to check the operation of the 4-way valve relay. Use to check whether there are any problems with the 4-way valve or 4-way valve coil.</p> <p>[Method of operation]</p> <ol style="list-style-type: none"> 1) Push ensure that D800 to D804 are off (or rapidly flashing) and that D805 is lit up. If D800 to D804 are slowly flashing or D805 is flashing then please push and hold down SW01 and SW02 at the same time for at least 5 seconds. D800 to D804 will turn off (or rapidly flash) and D805 turn on. 2) Push and hold down SW01 for at least 5 seconds. D804 will start slowly flashing. 3) Push SW01 until reaching the below [Confirmation of independent operation of outdoor fan] LED indication. <table border="1" data-bbox="520 1267 1294 1357"> <thead> <tr> <th>Confirmation of independent operation of outdoor fan</th> <th>D800</th> <th>D801</th> <th>D802</th> <th>D803</th> <th>D804</th> </tr> </thead> <tbody> <tr> <td></td> <td>○</td> <td>○</td> <td>●</td> <td>○</td> <td>◎</td> </tr> </tbody> </table> <p>●: Go OFF ○: Go ON ◎: Flash (5 times/sec)</p> <ol style="list-style-type: none"> 4) Push SW02 until D805 starts rapidly flashing. 5) Push and hold down SW02 for at least 5 seconds. D804 will start slowly flashing, D805 will turn on, and the 4-way valve resistance value relay operation will turn on. 6) Push and hold down SW01 and SW02 at the same time for at least 5 seconds or wait 2 minutes to return to normal control. 	Confirmation of independent operation of outdoor fan	D800	D801	D802	D803	D804		○	○	●	○	◎
Confirmation of independent operation of outdoor fan	D800	D801	D802	D803	D804									
	○	○	●	○	◎									

Check code	Outdoor LED display	Check and troubleshooting (Item without special mention Indicates part of outdoor unit.)
[P26]		<p>[Short-circuit of compressor drive element]</p> <pre> graph TD Q1{Are connections of compressor lead and reactor correct? (Check referring to the Wiring diagram.)} Q2{Does the same trouble occur in operation without compressor lead?} A1[Correct wiring.] A2[Replace outdoor P.C. board.] A3[Check compressor. (Layer short, etc.) Failure → Replace] Q1 -- NO --> A1 Q1 -- YES --> Q2 Q2 -- YES --> A2 Q2 -- NO --> A3 </pre>
[P29]		<p>[Position detection circuit trouble]</p> <div style="border: 1px solid black; padding: 5px; width: fit-content;"> <p>Check outdoor P.C. board. Failure → Replace * When replacing outdoor P.C.board, replace the fuse.</p> </div>
— No code		<p>[Other trouble] --- Compressor step-out from sudden changes in load etc. * Outdoor LED indication occurs but it automatically restarts and does not confirm any trouble. * May occur also when the compressor is open phase and wiring disconnected.</p>

8-2-5. Diagnostic Procedure for Each Check Code (Outdoor Unit)

Temperature sensor Temperature – Resistance value characteristic table

TA, TC, TCJ, TE, TS, TO sensors

TD, TL sensors

Representative value

Representative value

Temperature (°C)	Resistance value (kΩ)		
	(Minimum value)	(Standard value)	(Maximum value)
0	32.33	33.80	35.30
10	19.63	20.35	21.09
20	12.23	12.59	12.95
25	9.75	10.00	10.25
30	7.764	7.990	8.218
40	5.013	5.192	5.375
50	3.312	3.451	3.594
60	2.236	2.343	2.454
70	1.540	1.623	1.709
80	1.082	1.146	1.213
90	0.7740	0.8237	0.8761
100	0.5634	0.6023	0.6434

Temperature (°C)	Resistance value (kΩ)		
	(Minimum value)	(Standard value)	(Maximum value)
0	150.5	161.3	172.7
10	92.76	99.05	105.6
20	58.61	62.36	66.26
25	47.01	49.93	52.97
30	37.93	40.22	42.59
40	25.12	26.55	28.03
50	17.00	17.92	18.86
60	11.74	12.34	12.95
70	8.269	8.668	9.074
80	5.925	6.195	6.470
90	4.321	4.507	4.696
100	3.205	3.336	3.468

TA, TC, TCJ, TE, TS, TO sensors

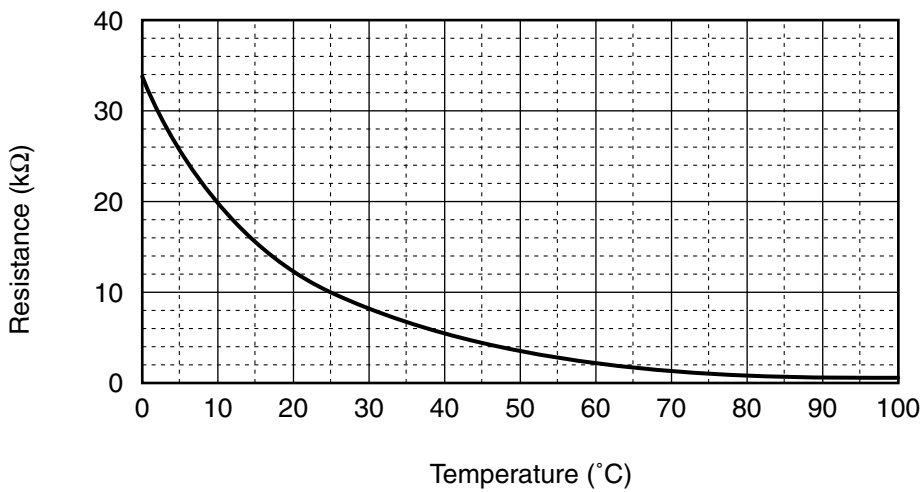

TD, TL sensors

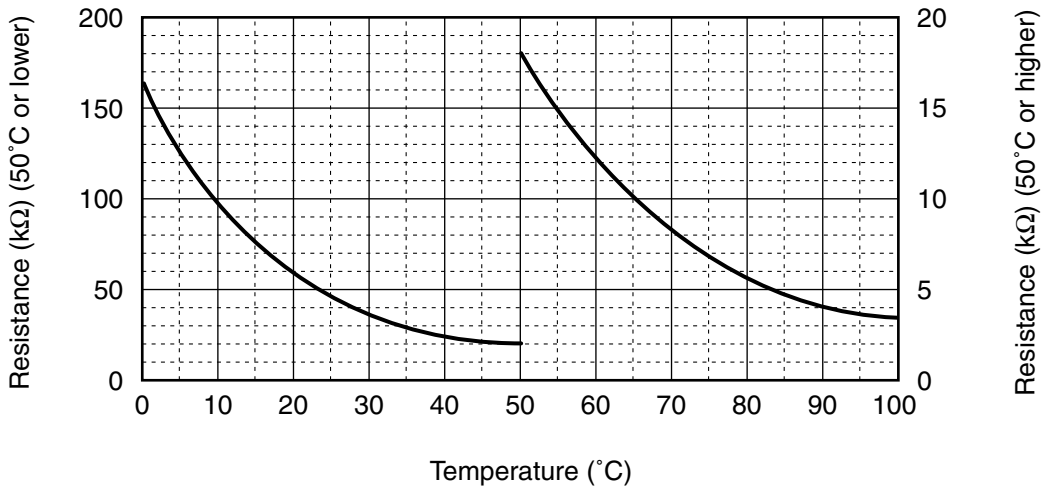

* As TH sensor (Outdoor unit heat sink temp. sensor) is incorporated in the outdoor control P.C. board, the resistance value cannot be measured.

8-3. Table Inspection of outdoor unit main parts

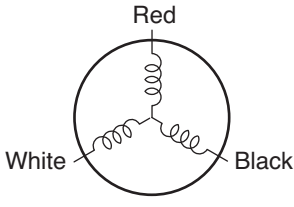
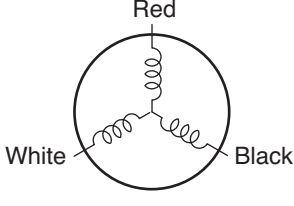
No.	Parts name	Checking procedure						
1	Compressor (Model : DA150A1T-21F)	<p>Measure the resistance value of each winding by using the tester.</p> <div style="display: flex; align-items: center; justify-content: center;">  <table border="1" style="margin-left: 20px;"> <thead> <tr> <th data-bbox="966 332 1209 390">Position</th> <th data-bbox="1209 332 1453 390">Resistance value</th> </tr> </thead> <tbody> <tr> <td data-bbox="966 390 1209 447">Red – White</td> <td data-bbox="1209 390 1453 562" rowspan="3" style="text-align: center; vertical-align: middle;">0.93 Ω</td> </tr> <tr> <td data-bbox="966 447 1209 505">White – Black</td> </tr> <tr> <td data-bbox="966 505 1209 562">Black – Red</td> </tr> </tbody> </table> <p style="text-align: right; margin-right: 20px;">Under 20°C</p> </div>	Position	Resistance value	Red – White	0.93 Ω	White – Black	Black – Red
Position	Resistance value							
Red – White	0.93 Ω							
White – Black								
Black – Red								
2	Fan motor (Model : ICF-140-A43-1)	<p>Measure the resistance value of each winding by using the tester.</p> <div style="display: flex; align-items: center; justify-content: center;">  <table border="1" style="margin-left: 20px;"> <thead> <tr> <th data-bbox="966 700 1209 757">Position</th> <th data-bbox="1209 700 1453 757">Resistance value</th> </tr> </thead> <tbody> <tr> <td data-bbox="966 757 1209 815">Red – White</td> <td data-bbox="1209 757 1453 929" rowspan="3" style="text-align: center; vertical-align: middle;">21.00±1.05 Ω</td> </tr> <tr> <td data-bbox="966 815 1209 872">White – Black</td> </tr> <tr> <td data-bbox="966 872 1209 929">Black – Red</td> </tr> </tbody> </table> <p style="text-align: right; margin-right: 20px;">Under 20°C</p> </div>	Position	Resistance value	Red – White	21.00±1.05 Ω	White – Black	Black – Red
Position	Resistance value							
Red – White	21.00±1.05 Ω							
White – Black								
Black – Red								

9. OTHERS

9-1. Calling of Check code History

<Contents>

The trouble contents in the past can be called.

<Procedure>

- 1** Push **SET** + **TEST** buttons simultaneously for 4 seconds or more to call the service check mode.

Service check goes on, the CODE No. **01** is displayed, and then the content of the latest alarm is displayed.

The number and trouble contents of the indoor unit in which a trouble occurred are displayed.

- 2** In order to monitor another check code history, push the set temperature **▼** / **▲** buttons to change the check code history No. (CODE No.).

CODE No. **01** (Latest) → CODE No. **04** (Old)

NOTE : 4 check code histories are stored in memory.

- 3** Pushing **TEST** button returns the display to usual display.

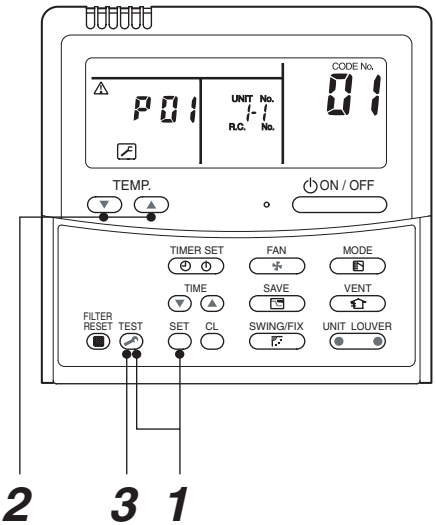

<Operation procedure>

1 → 2 → 3

Returned to usual display

REQUIREMENT

Do not push **CL** button, otherwise all the check code histories of the indoor unit are deleted.

NOTE

The electric portion of the refrigerant recovery SW on the sub-board is electrified, therefore be careful to an electric shock.

Indoor unit power-ON sequence

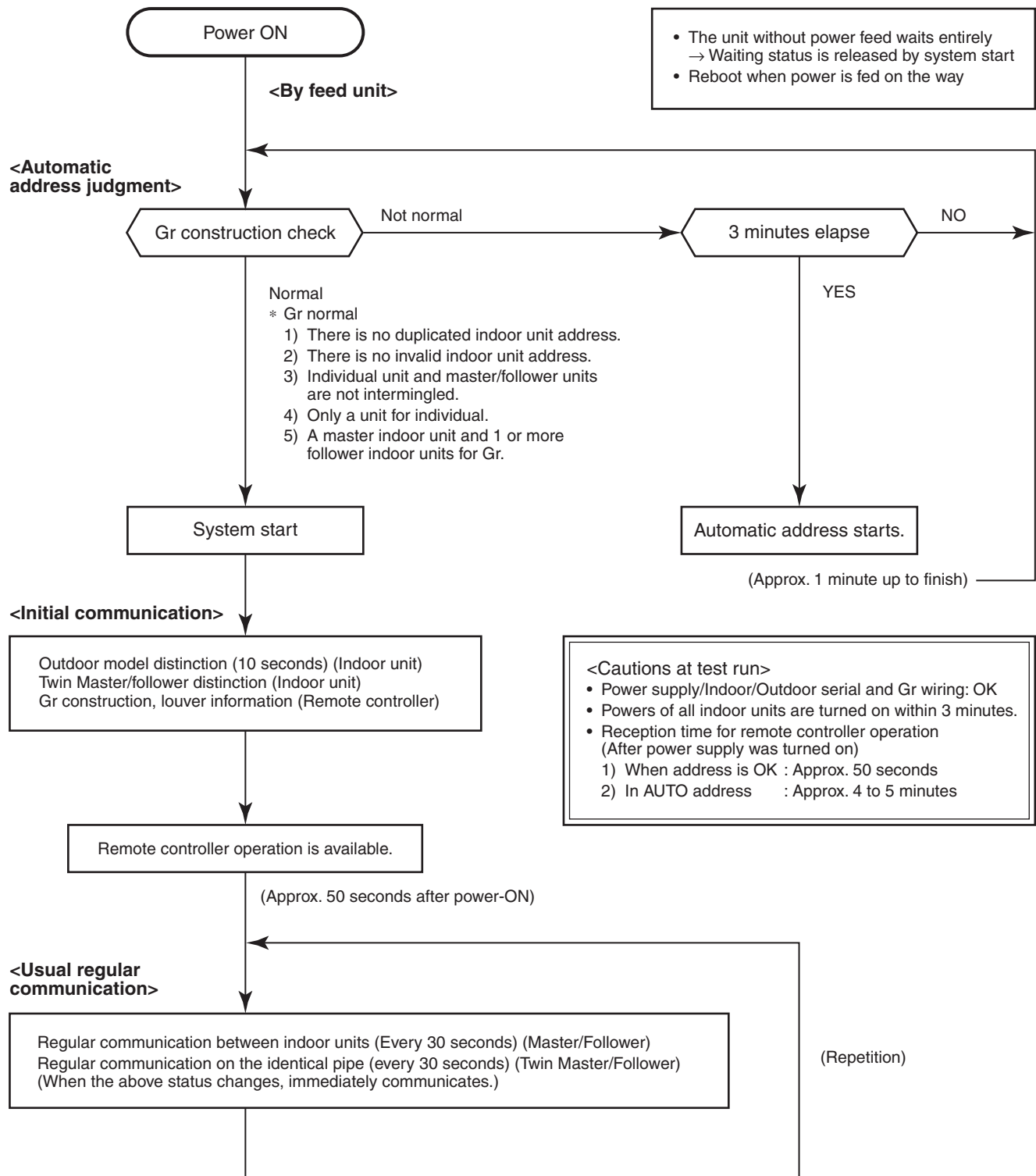

- In a group operation, if the indoor unit which was fed power after judgment of automatic address cannot receive regular communication from the master unit and regular communication on identical pipe within 120 seconds after power was turned on, it reboots (system reset).
→ The operation starts from judgment of automatic address (Gr construction check) again.
(If the address of the master unit was determined in the previous time, the power fed to the master unit and reboot works, the master unit may change though the indoor unit line address is not changed.)

9-2. Outdoor Unit

Various status displays and operations can be accessed using the push buttons (service switches) on the outdoor Control P.C. board and LED display.

Service switch (SW01 and SW02) operation

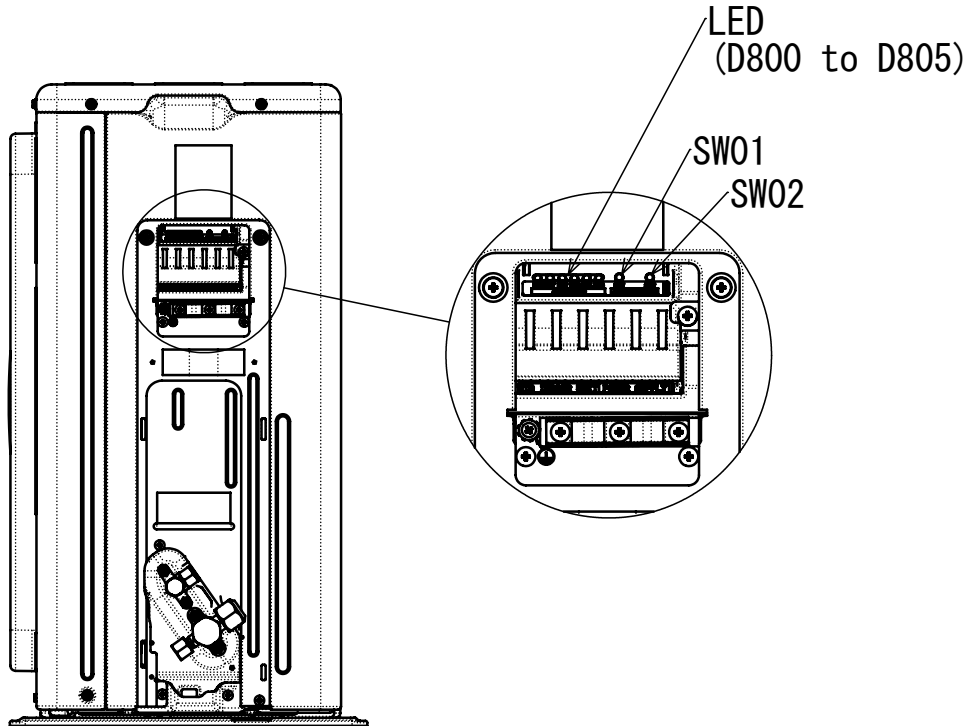

Concerning the LED display

- The LED display has 4 patterns.
 ○ : Go ON ● : Go OFF ◎ : flash (5 times/sec) ◇ : flashing (1 time/sec)
- The initial state of the LED display is as shown on the right with D805 lit up.
 If not in the initial state (D805 flashing) then it can be returned to the initial state by pushing and holding down SW01 and SW02 at the same time for 5 seconds.

LED display: Initial state

D800 to D804 : Go Off and flash (5 times/sec)
 D805 : Go ON

	D800	D801	D802	D803	D804	D805
LED	○ (Yellow)	○ (Yellow)	○ (Yellow)	○ (Yellow)	○ (Yellow)	○ (Green)

1. Various settings available via the outdoor unit (Existing pipe, Maximum frequency change, Snow guard fan control, Cooling only setup, etc.)

(1) Service switch setting

Various settings can be made using the service switches

[Method of operation]

- 1) Ensure the LED display shows the initial status. If not then ensure to restore the initial status.
- 2) Press SW01 for at least 5 seconds. D804 will start slowly flashing.
- 3) Push SW01 several times until reaching the required LED display function.

Functions	LED display					Control content																											
Existing pipe setting	D800 ●	D801 ●	D802 ○	D803 ●	D804 ◎	Activate when existing Ø19.1 piping is used. Note that in this case, depending on the outdoor and indoor air temperature, the heating capacity may drop.																											
Cooling only setting	D800 ○	D801 ○	D802 ●	D803 ●	D804 ◎	Cooling only setting. (Can also be changed using the DN code [0F] on the wired remote control).																											
Snow guard fan control	D800 ●	D801 ○	D802 ●	D803 ●	D804 ◎	The snow guard fan control enables snow to be diverted from the path of the fan and heat exchanger, thereby protecting the fan motor. And even when the compressor is not in use but the external temperature is less than 7°C ensure the outdoor fan is going using W3.																											
Maximum frequency change	D800 ●	D801 ●	D802 ●	D803 ○	D804 ◎	Enable this if you wish to lower the maximum compressor frequency. It will lower the maximum frequency during both cooling and heating. Note however it does reduce the maximum capacity. Maximum compressor frequency (rps)																											
						<table border="1"> <thead> <tr> <th rowspan="2">Model</th> <th colspan="2">GP80</th> <th colspan="2">GP110</th> <th colspan="2">GP140</th> </tr> <tr> <th>Cooling</th> <th>Heating</th> <th>Cooling</th> <th>Heating</th> <th>Cooling</th> <th>Heating</th> </tr> </thead> <tbody> <tr> <td>Standard status</td> <td>80.4</td> <td>99.6</td> <td>64.2</td> <td>78.6</td> <td>77.4</td> <td>99.6</td> </tr> <tr> <td>When setting is valid</td> <td>74.4</td> <td>74.4</td> <td>58.8</td> <td>58.8</td> <td>74.4</td> <td>74.4</td> </tr> </tbody> </table>	Model	GP80		GP110		GP140		Cooling	Heating	Cooling	Heating	Cooling	Heating	Standard status	80.4	99.6	64.2	78.6	77.4	99.6	When setting is valid	74.4	74.4	58.8	58.8	74.4	74.4
Model	GP80		GP110		GP140																												
	Cooling	Heating	Cooling	Heating	Cooling	Heating																											
Standard status	80.4	99.6	64.2	78.6	77.4	99.6																											
When setting is valid	74.4	74.4	58.8	58.8	74.4	74.4																											

○: Go ON ●: Go OFF ◎: Flash (5 times/sec)

- 4) Push SW01 until D805 starts rapidly flashing.
 - 5) Press and hold down SW02 for at least 5 seconds. D804 will start slowly flashing and D805 will light up, and the various settings will take effect.
 - 6) To make more settings repeat steps 3) to 5).
 - 7) To invalidate any settings made in steps 1 to 3 press SW01 to turn off D805.
 - 8) Press and hold down SW02 for at least 5 seconds. D804 will start to slowly flash and D805 will turn off and the various settings will be invalidated.
- * If any unclear point arises during an operation then can return to step 1 by pressing and holding down SW01 and SW02 at the same time for at least 5 seconds.

Various settings confirmation method

Whether the various settings are in effect or not can be confirmed.

- 1) Ensure the LED display shows the initial status. If not then ensure to restore the initial status.
- 2) Push SW01 for at least 5 seconds. D804 will start slowly flashing.
- 3) Push SW01 several times until reaching the desired function on the LED display. If the setting is valid D804 and D805 will rapidly flash. (If the setting is invalid then D804 will rapidly flash but D805 will turn off.)
- 4) Push and hold down SW01 and SW02 at the same time for at least 5 seconds to return the LED display to the initial state.

Returning to the factory default settings

The factory default stings can be restored using the following procedure.

- 1) Ensure the LED display shows the initial state. If not then ensure to return it to the initial state.
- 2) Push and hold down SW01 for at least 5 seconds and confirm that D804 is slowly flashing.
- 3) Push SW01 several times until reaching the LED display (D800 to D805) shown on the right or 'Returning to the default factory setting LED display'.
- 4) Push and hold down SW02 for at least 5 seconds and confirm that D804 is slowly flashing.
- 5) Push and hold down SW01 and SW02 at the same time for at least 5 seconds to return to the initial state LED display.

Return to default factory setting LED display					
D800	D801	D802	D803	D804	D805
●	●	●	●	◎	●
○: Go ON ●: Go OFF ◎: Flash (5 times/sec)					

Sub-P.C. board switch and LED arrangement diagram

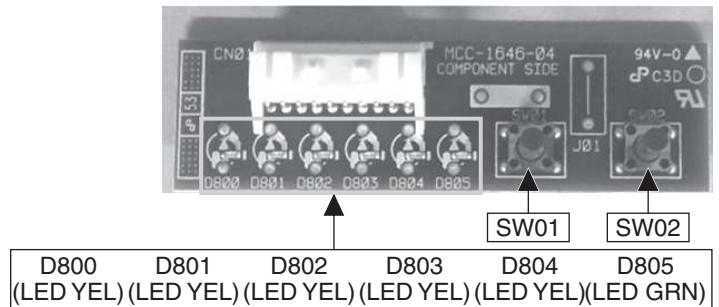

2. Service support functions (LED display and switch operation)

(1) LED display switching (SW01 and SW02 operation)

(1)-1. Display switch list

Service switches SW01 and SW02 can be used to change the display content of LEDs D800 to D805 on the outdoor unit.

[Method of Operation]

- 1) Ensure the LED display shows the initial state. If not then ensure to return it to the initial state.
- 2) Push SW01 several times until reaching the desired display item.

LED display						Control content
D800	D801	D802	D803	D804	D805	Trouble indication (Current trouble) Displays the current trouble. Will not appear if no trouble has occurred. (Refer to (1)-2-1)
●	●	●	●	●	◎	
D800	D801	D802	D803	D804	D805	Trouble indication (Latest trouble: latest and including current trouble) Previous trouble can be checked using this setting, for example, after previous trouble has been resolved (and even after the power has been turned off). * If trouble is currently occurring then the same content will be displayed. * TO sensor trouble only and thus this setting does not display. (Check using the current trouble setting). (Refer to (1)-2-2)
○	●	●	●	●	◎	
D800	D801	D802	D803	D804	D805	Discharge temperature sensor (TD) indication Displays the discharge temperature sensor (TD) value. (Refer to (1)-3)
●	○	●	●	●	◎	
D800	D801	D802	D803	D804	D805	Outdoor heat exchanger temperature sensor (TE) indication Displays the outdoor heat exchanger temperature sensor (TE) value. (Refer to (1)-3)
○	○	●	●	●	◎	
D800	D801	D802	D803	D804	D805	Outdoor heat exchanger temperature sensor (TL) indication Displays the outdoor heat exchanger sensor (TL) value. (Refer to (1)-3)
●	○	○	●	●	◎	
D800	D801	D802	D803	D804	D805	Inlet temperature sensor (TS) indication. Displays the inlet temperature sensor (TS) value. (Refer to (1)-3)
●	●	○	●	●	◎	
D800	D801	D802	D803	D804	D805	Outdoor external temperature sensor (TO) indication. Displays the outdoor external temperature sensor (TO) value. (Refer to (1)-3)
○	●	○	●	●	◎	
D800	D801	D802	D803	D804	D805	Heat sink temperature sensor (TH) indication. Displays the heat sink temperature sensor (TH) value. (Refer to (1)-3)
○	○	○	●	●	◎	
D800	D801	D802	D803	D804	D805	Current indication. Displays the outdoor unit current value. (Refer to (1)-3)
○	●	●	○	●	◎	
D800	D801	D802	D803	D804	D805	Compressor operation frequency indication. Displays the operating frequency of the compressor. (Refer to (1)-3)
●	○	●	○	●	◎	
D800	D801	D802	D803	D804	D805	PMV opening indication. Displays the degree to which the PMV is open. (Refer to (1)-3)
○	○	●	○	●	◎	
D800	D801	D802	D803	D804	D805	Indoor suction temperature sensor (TA) indication. Displays the indoor suction temperature sensor (TA) value. (Refer to (1)-3)
●	●	○	○	●	◎	
D800	D801	D802	D803	D804	D805	Indoor heat exchange temperature sensor (TC) indication. Displays the indoor heat exchange temperature sensor (TC) value. (Refer to (1)-3)
○	●	○	○	●	◎	
D800	D801	D802	D803	D804	D805	Indoor heat exchanger sensor (TCJ) indication. Displays the indoor heat exchanger sensor (TCJ) value. (Refer to (1)-3)
●	○	○	○	●	◎	
D800	D801	D802	D803	D804	D805	Refrigerant leak indication. Displays if a certain amount of refrigerant has leaked. (Refer to (1)-4)
●	●	●	○	●	◎	

○: Go ON ●: Go OFF ◎: Flash (5 times/sec)

- 3) Push SW02 to switch to the desired display item.
- 4) To access the other display items repeat steps 1) to 3).
- 5) Before exiting ensure to perform step 1) and set the LED to the initial state (current abnormality indication).

(1)-2. Trouble display

Current and the latest trouble (latest and including the present trouble) can be checked using the lighting status of the LEDs D800 to D805 on the outdoor unit.

(1)-2-1. Current trouble indication

LED indication						Name of trouble	Wired remote control trouble code
D800	D801	D802	D803	D804	D805		
●	●	●	●	●	○	Normal	—
◎	●	●	●	●	○	Discharge temp. sensor (TD) trouble	F04
●	◎	●	●	●	○	Heat exchanger temp. sensor (TE) trouble	F06
◎	◎	●	●	●	○	Heat exchanger temp. sensor (TL) trouble	F07
●	●	◎	●	●	○	Outside temp. sensor (TO) trouble	F08
◎	●	◎	●	●	○	Suction temp. sensor (TS) trouble	F12
●	◎	◎	●	●	○	Heat sink temp. sensor (TH) trouble	F13
◎	◎	◎	●	●	○	Miss-mounting of sensor (TE, TS)	F15
●	◎	●	◎	●	○	EEPROM trouble	F31
◎	◎	●	◎	●	○	Compressor break down	H01
●	●	◎	◎	●	○	Compressor lock	H02
◎	●	◎	◎	●	○	Current detection circuit trouble	H03
●	◎	◎	◎	●	○	Case thermostat operation	H04
●	●	●	●	◎	○	Unset model type	L10
◎	●	●	●	◎	○	Communication trouble between MCUs	L29
●	◎	●	●	◎	○	Discharge temp. sensor trouble	P03
◎	◎	●	●	◎	○	High pressure SW operation	P04
●	●	◎	●	◎	○	Power supply trouble	P05
●	◎	◎	●	◎	○	Heat sink overheat trouble	P07
◎	◎	◎	●	◎	○	Gas leak detection	P15
●	●	●	◎	◎	○	4-way valve reversal trouble	P19
◎	●	●	◎	◎	○	High pressure protective operation	P20
●	◎	●	◎	◎	○	Fan system trouble	P22
◎	◎	●	◎	◎	○	Short-circuit of compressor drive element	P26
●	●	◎	◎	◎	○	Position detection circuit trouble	P29

○: Go ON ●: Go OFF ◎: Flash (5 times/sec)

(1)-2-2. Latest (including current) trouble indication

LED indication						Name of trouble
D800	D801	D802	D803	D804	D805	
●	●	●	●	●	◇	Normal
◎	●	●	●	●	◇	Discharge temp. sensor (TD) trouble
●	◎	●	●	●	◇	Heat exchanger temp. sensor (TE) trouble
◎	◎	●	●	●	◇	Heat exchanger temp. sensor (TL) trouble
●	●	◎	●	●	◇	Outside temp. sensor (TO) trouble
◎	●	◎	●	●	◇	Suction temp. sensor (TS) trouble
●	◎	◎	●	●	◇	Heat sink temp. sensor (TH) trouble
◎	◎	◎	●	●	◇	Miswiring of heat exchanger temp. sensor (TE, TS)
●	◎	●	◎	●	◇	EEPROM trouble
◎	◎	●	◎	●	◇	Compressor break down
●	●	◎	◎	●	◇	Compressor lock
◎	●	◎	◎	●	◇	Current detection circuit trouble
●	◎	◎	◎	●	◇	Case thermostat operation
●	●	●	●	◎	◇	Unset model type
◎	●	●	●	◎	◇	Communication trouble between MCUs
●	◎	●	●	◎	◇	Discharge temp. sensor trouble
◎	◎	●	●	◎	◇	High pressure SW operation
●	●	◎	●	◎	◇	Power supply trouble
●	◎	◎	●	◎	◇	Heat sink overheat trouble
◎	◎	◎	●	◎	◇	Gas leak detection
●	●	●	◎	◎	◇	4-way valve reversal trouble
◎	●	●	◎	◎	◇	High pressure protective operation
●	◎	●	◎	◎	◇	Fan system trouble
◎	◎	●	◎	◎	◇	Short-circuit of compressor drive element
●	●	◎	◎	◎	◇	Position detection circuit trouble

○: Go ON ●: Go OFF ◎: Flash (5 times/sec) ◇: flashing (1 time/sec)

(1)-3. Sensor, current, compressor operation frequency, PMV opening indication

Interface (CDB) P.C. board detected values (for example temperature and current sensor values) can be easily checked.

* Temperature sensors ... TD, TE, TL, TS, TO, TH, TA, TC, TCJ

* Current Current sensor (CT) value detected

LED indication						Temperature sensor (°C)	Current (A)	Compressor frequency (rps)	Degree of PMV opening (pls)
D800 (YEL)	D801 (YEL)	D802 (YEL)	D803 (YEL)	D804 (YEL)	D805 (GRN)				
●	●	●	●	●	◇	Less than -25	0 ~	0 ~	0 ~ 19
○	●	●	●	●	◇	-25 ~	1 ~	5 ~	20 ~ 39
●	○	●	●	●	◇	-20 ~	2 ~	10 ~	40 ~ 59
○	○	●	●	●	◇	-15 ~	3 ~	15 ~	60 ~ 79
●	●	○	●	●	◇	-10 ~	4 ~	20 ~	80 ~ 99
○	●	○	●	●	◇	-5 ~	5 ~	25 ~	100 ~ 119
●	○	○	●	●	◇	0 ~	6 ~	30 ~	120 ~ 139
○	○	○	●	●	◇	5 ~	7 ~	35 ~	140 ~ 159
●	●	●	○	●	◇	10 ~	8 ~	40 ~	160 ~ 179
○	●	●	○	●	◇	15 ~	9 ~	45 ~	180 ~ 199
●	○	●	○	●	◇	20 ~	10 ~	50 ~	200 ~ 219
○	○	●	○	●	◇	25 ~	11 ~	55 ~	220 ~ 239
●	●	○	○	●	◇	30 ~	12 ~	60 ~	240 ~ 259
○	●	○	○	●	◇	35 ~	13 ~	65 ~	260 ~ 279
●	○	○	○	●	◇	40 ~	14 ~	70 ~	280 ~ 299
○	○	○	○	●	◇	45 ~	15 ~	75 ~	300 ~ 319
●	●	●	●	○	◇	50 ~	16 ~	80 ~	320 ~ 339
○	●	●	●	○	◇	55 ~	17 ~	85 ~	340 ~ 359
●	○	●	●	○	◇	60 ~	18 ~	90 ~	360 ~ 379
○	○	●	●	○	◇	65 ~	19 ~	95 ~	380 ~ 399
●	●	○	●	○	◇	70 ~	20 ~	100 ~	400 ~ 419
○	●	○	●	○	◇	75 ~	21 ~	105 ~	420 ~ 439
●	○	○	●	○	◇	80 ~	22 ~	110 ~	440 ~ 459
○	○	○	●	○	◇	85 ~	23 ~	115 ~	460 ~ 479
●	●	●	○	○	◇	90 ~	24 ~	120 ~	480 ~ 499
○	●	●	○	○	◇	95 ~	25 ~	125 ~	500
●	○	●	○	○	◇	100 ~	26 ~	130 ~	—
○	○	●	○	○	◇	105 ~	27 ~	135 ~	—
●	●	○	○	○	◇	110 ~	28 ~	140 ~	—
○	●	○	○	○	◇	115 ~	29 ~	145 ~	—
●	○	○	○	○	◇	120 ~	30 ~	150 ~	—
○	○	○	○	○	◇	Sensor trouble	31 or more	155 or more	—

○: Go ON ●: Go OFF ◇: flashing (1 time/sec)

(1)-4. Refrigerant leak detection function

Monitors the amount of refrigerant being circulated based on the temperature sensors, compressor rotation speed, PMV opening during operation, and detects any refrigerant leaks during operation and indicates it using the LEDs on the outdoor unit.

CAUTION

- * Detects any slow leaks at the stages of not cool not heat and trouble stoppages' during operation but may not detect fast leaks sometimes.
- * Refrigerant leaks may even be detected because of refrigerant circulation failures due to PMV (Pulse Motor Valve) blockages, operation failures, capillary blockages, strainer blockages, etc.
- * Refrigerant leak detection may not be possible depending on the external air temperature conditions during operation.

If any refrigerant leaks are detected ensure to identify where the leak is, recover the remaining refrigerant, and then recharge with the correct amount using the appropriate methods.

[Confirmation method]

- 1) Ensure the LED display shows the initial state. If not then it can be returned to the initial state by pushing and holding down SW01 and SW02 at the same time for at least 5 seconds.
- 2) Push SW01 several times until reaching the 'refrigerant leak indication' LED display.

D800	D801	D802	D803	D804	D805	Refrigerant leak indication Displays if a certain amount of refrigerant has leaked.
●	●	●	○	●	◎	

○: Go ON ●: Go OFF ◎: Flash (5 times/sec)

- 3) Briefly pushing SW02 enables the presence of a leak to be detected using the LED display.

D800	D801	D802	D803	D804	D805	Judgment
●	●	●	●	●	◇	No refrigeration leak detected
○	●	●	●	●	◇	Refrigeration leak detected

○: Go ON ●: Go OFF ◇: Flash (1 time/sec)

- 4) Before exiting, push and hold down SW01 and SW02 at the same time for at least 5 seconds and set the LED to the initial state.

(2) Maintenance inspections Special operations (SW01 and SW02 operations)

The following special maintenance and inspection operations can be carried out using the service switches SW01 and SW02.

[Method of operation]

- 1) Ensure the LED display shows the initial state. If not then please ensure to return it to the initial state.
- 2) Push and hold down SW01 for at least 5 seconds. D804 will start slowly flashing.
- 3) Push SW01 until reaching the LED display function you wish to set.

Special operations	LED display	Control content
Refrigerant recovery operation	D800 D801 D802 D803 D804 ○ ● ● ● ◎	The outdoor unit performs cooling operations. Indoor units do not operate with just this operation and hence do any fan only operations in advance. (Refer to 1.)
PMV fully open operation	D800 D801 D802 D803 D804 ○ ● ○ ● ◎	PMV (Puls Motor Valve) fully opens. Perform step 6) below or returns to normal control after 2 minutes. (⇒ Note 1)
PMV fully closed operation	D800 D801 D802 D803 D804 ● ○ ○ ● ◎	PMV (Puls Motor Valve) fully closed. Perform step 6) below or returns to normal control after 2 minutes. (⇒ Note 1)
PMV intermediate open operation	D800 D801 D802 D803 D804 ○ ○ ○ ● ◎	Sets the PMV (Puls Motor Valve) to intermediate open (500 pulses). Perform step 6) below or returns to normal control after 2 minutes. (⇒ Note 1)
Indoor heating test command	D800 D801 D802 D803 D804 ○ ● ● ○ ◎	Performs a heating test run. Carrying out step 6) below returns to normal control. (⇒ Note 2)
Indoor cooling test run command	D800 D801 D802 D803 D804 ● ○ ● ○ ◎	Performs a cooling test run. Carrying out step 6) below returns to normal control. (⇒ Note 2)
Forced fan motor operation	D800 D801 D802 D803 D804 ○ ○ ● ○ ◎	Forcibly operates the fan motor. Perform step 6) below or returns to normal control after 2 minutes. (⇒ Note 1)
4 way valve relay operation	D800 D801 D802 D803 D804 ● ● ○ ○ ◎	Turns on the 4 way valve relay. Perform step 6) below or returns to normal control after 2 minutes. (⇒ Note 1)

○: Go ON ●: Go OFF ◎: Flash (5 times/sec)

Note 1 : The operations can take place while the equipment is on but it is better if it has been turned off first. A sudden change in pressure could occur while the operations are taking place, which can be dangerous.

Note 2 : Trial indoor cooling operation request/trial indoor heating operation request

Cooling/Heating test operations can only take place from the outdoor unit when combined with the following indoor units. ensure to utilize the outdoor unit.
 Test runs supported : 5 series or later indoor units
 Not supported : Indoor units other than above. In addition, any when twin connections include any other indoor units than above.

Caution) Forced test operations using this setting cannot be cancelled using the indoor remote control. Refer to (6) below.

- 4) Push SW02 until D805 starts rapidly flashing.
- 5) Push and hold down SW02 for at least 5 seconds. D804 will start slowly flashing and D805 will turn on and the special operation will take effect.
- 6) To invalidate any of the various settings push and hold down SW01 and SW02 at the same time for at least 5 seconds. D800 to D804 will be off (or rapidly flashing) and D805 lit up (initial state: current trouble indication) and the special operation will have been disabled (normal control).

* If any uncertainty arises then push and hold down SW01 and SW02 at the same time for at least 5 seconds. You will return to step 1).



3. Outdoor application operation

Optional connector kit (TCB-PCOS1E2)



- (1) Peak-cut control
 - Saves the power of the outdoor unit by the external peak-cut signal to suppress temporary peak power dissipation.
 - The power saving can be switched to three levels: 75%, 50%, and operation stop.
- (2) Night operation
 - Reduces the capacity of the air conditioner by the input signal from a commercially available timer (procured locally) regardless of the outside air temperature or load to reduce operating noise.
- (3) Compressor output
 - Turns on the no-voltage contact output while the compressor is operating.

10. DETACHMENTS

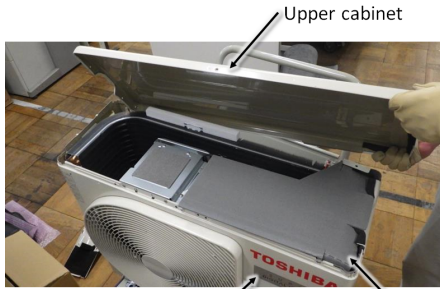
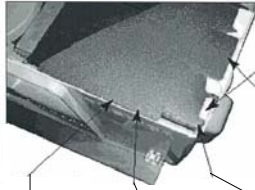
10-1. RAV-GP561ATP*

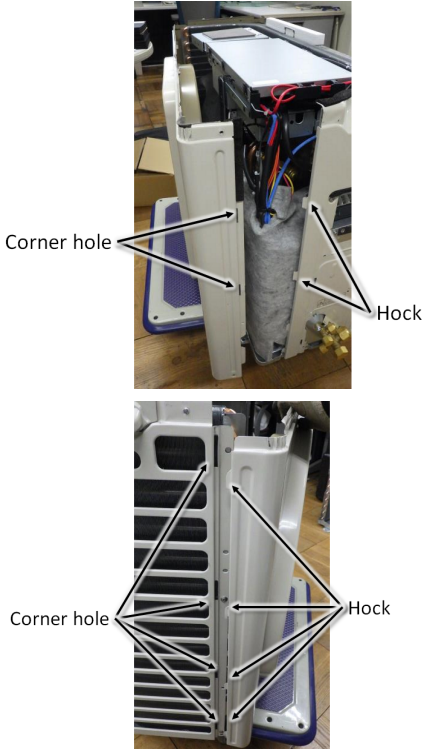

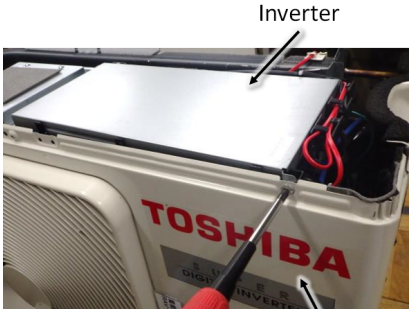
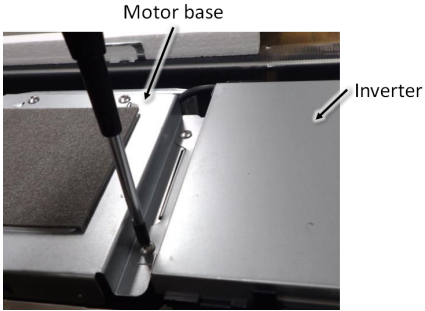
No.	Part name	Procedure	Remarks
①	Common procedure	<p>1. Detachment</p> <div style="border: 1px solid black; padding: 5px; margin-bottom: 10px;"> <p align="center">NOTE</p> <p>Wear gloves for this job. Otherwise, you may injure your hands on the parts, etc.</p> </div> <ol style="list-style-type: none"> 1) Stop operation of the air conditioner, and turn off the main switch of the breaker for air conditioner. 2) Remove the valve cover. (ST2TØ4 x 10L 3 pcs.) <ul style="list-style-type: none"> • After removing screw, remove the valve cover pulling it downward. 3) Remove the wiring cover. (ST2TØ4 x 10L 1 pcs.) <ul style="list-style-type: none"> • After removing screw, remove the wiring cover pulling it upward. 4) Remove cord clamp (ST2TØ4 x 14L 3 pcs.), and then remove connecting cable. 5) Remove the upper cabinet. (ST1TØ4 x 10L 5 pcs.) <ul style="list-style-type: none"> • After removing screws, remove the upper cabinet pulling it upward. <p>2. Attachment</p> <ol style="list-style-type: none"> 1) Attach the water-proof cover. <div style="border: 1px solid black; padding: 5px; margin-bottom: 10px;"> <p align="center">NOTE</p> <p>The water-proof cover must be attached without fail in order to prevent rain water, etc. from entering inside the indoor unit.</p> </div> <ol style="list-style-type: none"> 2) Attach the upper cabinet. (ST1TØ4 x 10L 5 pcs.) 3) Perform cabling of connecting cable, and attach the cord clamp. <ul style="list-style-type: none"> • Fix the cord clamp by tightening the screws (ST2TØ 4 x 14L 3 pcs.), fitting 2 concave parts of the cord clamp to each connecting cables. 4) Attach the valve cover. (ST2TØ 4 x 10L 2 pcs.) <ul style="list-style-type: none"> □ Insert the upper part into the square hole of the side cabinet, set hook claws of the valve cover to square holes (at three positions) of the main unit, and attach it pushing upward, 	 <p>Valve cover</p>  <p>Wiring cover Cord clamp</p>  <p>Upper cabinet Front cabinet Water-proof cover</p>  <div style="border: 1px solid black; padding: 2px; margin-bottom: 5px;"> <p>These 2 bending parts shall be put inside of a unit by bending these 2 ports.</p> </div> <div style="border: 1px solid black; padding: 2px; margin-bottom: 5px;"> <p>This part shall be put on the side cabinet.</p> </div> <div style="border: 1px solid black; padding: 2px; margin-bottom: 5px;"> <p>Fit the corner of the water proof cover to the corner of the front cabinet.</p> </div> <div style="border: 1px solid black; padding: 2px; margin-bottom: 5px;"> <p>This line shall be pavallel to the front cabinet</p> </div> <div style="border: 1px solid black; padding: 2px; margin-bottom: 5px;"> <p>This part shall cover the gap between the inverter box and the front cabinet.</p> </div> <div style="border: 1px solid black; padding: 5px; text-align: center; margin-top: 10px;"> <p>How to mount the water-proof cover</p> </div>

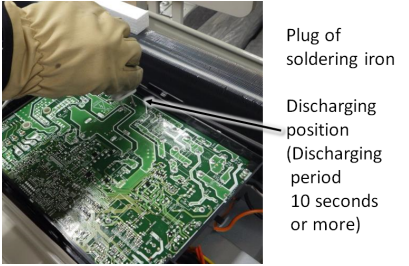
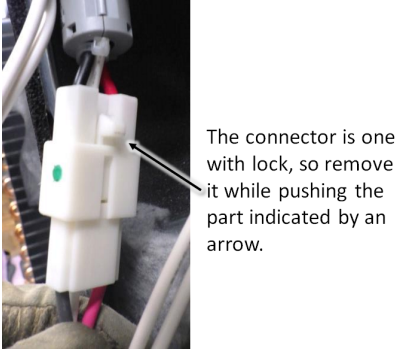

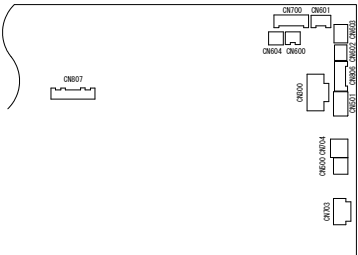
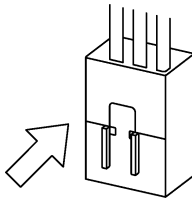
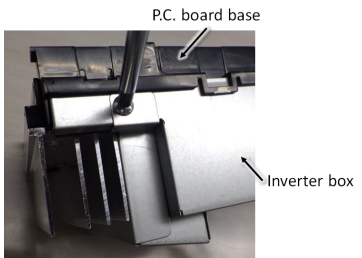
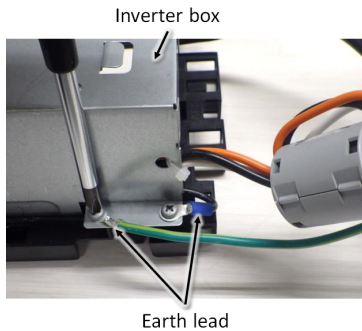
No.	Part name	Procedure	Remarks
②	Front cabinet	<p>1. Detachment</p> <ol style="list-style-type: none"> 1) Perform step 1 in ①. 2) Remove the fixing screws (ST2TØ4 × 10L 2 pcs.) used to secure the front cabinet and inverter cover, the screws (ST2TØ4 × 10L 4 pcs.) used to secure the front cabinet at the bottom, and the fixing screws (ST2TØ4 × 10L 2 pcs.) used to secure the motor base. <ul style="list-style-type: none"> • The front cabinet is fitted into the side cabinet (left) at the front left side so pull up the top of the front cabinet to remove it. <p>2. Attachment</p> <ol style="list-style-type: none"> 1) Insert the claw on the front left side into the side cabinet (left). 2) Hook the bottom part of the front right side onto the concave section of the bottom plate. Insert the claw of the side cabinet (right) into the square hole in the front cabinet. 3) Return the screws that were removed above to their original positions and attach them. 	 <p>The top photograph shows the front cabinet being detached from the side cabinet. Arrows point to a 'Corner hole' on the left side and a 'Hook' on the right side. The bottom photograph shows the front cabinet being attached to the side cabinet. Arrows point to a 'Corner hole' on the left side and a 'Hook' on the right side.</p>

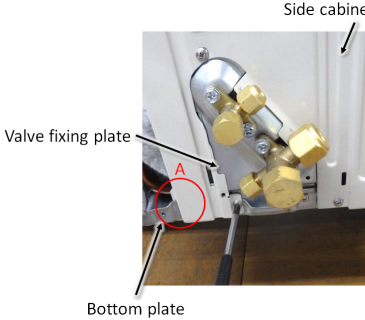
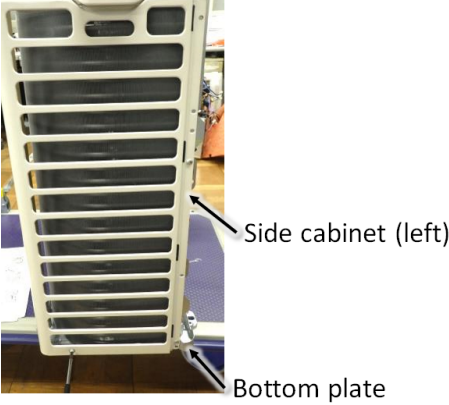
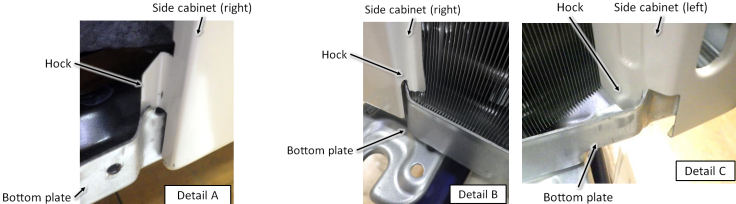
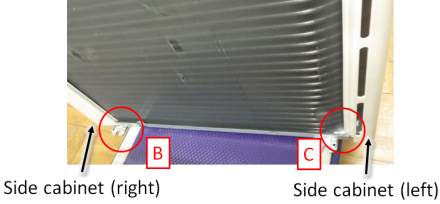
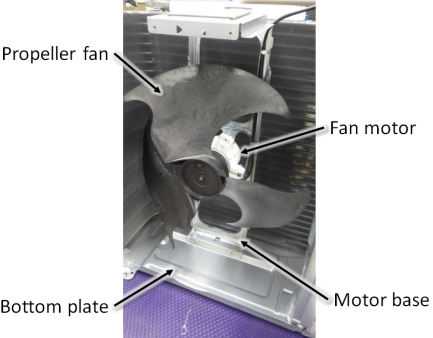

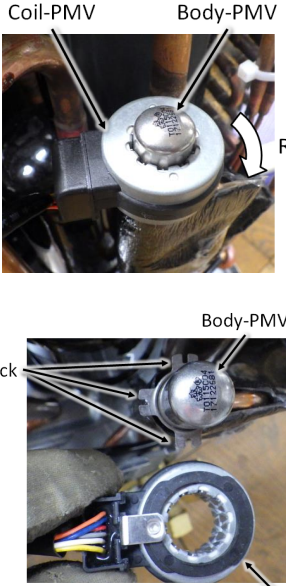

No.	Part name	Procedure	Remarks
③	Inverter assembly	<p>1) Perform work of item 1 in ①.</p> <p>2) Remove screw (ST2TØ4 × 10L 2 pcs.) of the upper part of the front cabinet.</p> <ul style="list-style-type: none"> • If removing the inverter cover in this condition, P.C. board can be checked. • If there is no space above the unit, perform work of 1 in ②. <div data-bbox="416 472 978 573" style="border: 1px solid black; padding: 5px;"> <p>Be careful to check the inverter because high-voltage circuit is incorporated in it.</p> </div> <p>3) Perform discharging by connecting ⊕, ⊖ polarity by discharging resistance (approx. 100Ω40W) or plug of soldering iron to ⊕, ⊖ terminals a of the C10 (printed "WARNING HIGH VOLTAGE" is attached.) electrolytic capacitor (500μF) on P.C. board.</p> <div data-bbox="416 792 978 974" style="border: 1px solid black; padding: 5px;"> <p>Be careful to discharge the capacitor because the electrolytic capacitor cannot naturally discharge and voltage remains according to trouble type in some cases.</p> </div> <div data-bbox="416 1003 978 1167" style="border: 1px solid black; padding: 5px;"> <p style="text-align: center;">NOTE</p> <p>This capacitor is one with mass capacity. Therefore, it is dangerous that a large spark generates if short-circuiting between ⊕, ⊖</p> </div> <p>4) Remove screw (ST2TØ4 × 10L 4pcs.) fixing the terminal part of inverter box to the side cabinet (right).</p> <p>5) Remove the front cabinet by performing step 1 in ②, and remove the fixing screws (ST2TØ4 × 10L) for securing the partition plate and inverter box.</p> <p>6) Remove the fixing screw (ST2TØ4 × 10L 1 pcs.) securing the wiring cover and inverter box.</p> <ul style="list-style-type: none"> • After removing screw, remove the wiring cover pulling it downward. <p>7) Remove the fixing screw (ST2TØ4 × 10L 2 pcs.) for securing the motor base and inverter box.</p> <p>8) Remove various lead wires from the holder at upper part of the inverter box.</p> <p>9) Pull the inverter box upward.</p> <p>10) Disconnect connectors of various lead wires. (Refer to next page for detail of leads and connector)</p> <div data-bbox="416 1868 978 2033" style="border: 1px solid black; padding: 5px;"> <p style="text-align: center;">Requirement</p> <p>As each connector has a lock mechanism, avoid to remove the connector by holding the lead wire, but by holding the connector.</p> </div>	<div data-bbox="1023 226 1433 577">  <p style="text-align: center;">Inverter</p> <p style="text-align: center;">Front cabinet</p> </div> <div data-bbox="1023 618 1449 927">  <p style="text-align: center;">Motor base</p> <p style="text-align: center;">Inverter</p> </div> <div data-bbox="1023 987 1433 1245">  <p style="text-align: center;">Inverter cover</p> </div> <div data-bbox="1023 1267 1433 1532">  <p style="text-align: center;">Plug of soldering iron</p> <p style="text-align: center;">Discharging position (Discharging period 10 seconds or more)</p> </div> <div data-bbox="1023 1547 1433 1895">  <p style="text-align: center;">The connector is one with lock, so remove it while pushing the part indicated by an arrow.</p> </div> <p style="text-align: center;">Be sure to remove the connector by holding the connector, not by pulling the lead wire.</p>

No.	Part name	Procedure	Remarks
③	Inverter assembly	<p>Disconnect the leads and connectors connected to the other parts from the control board assembly.</p> <p>1) Leads</p> <ul style="list-style-type: none"> • Lead connected to compressor : Disconnect the connector (3P). • Lead connected to reactor : Disconnect the two connectors (2P). <p>2) Connectors</p> <p>CN300 : Outdoor fan motor (3P: white) CN600 : TE sensor (2P: white)* CN700 : PMV (6P: white) CN603 : TS sensor (3P: white)* CN601 :TD sensor (3P: white)* CN602 : TO sensor (2P: yellow) CN704 : 4 Way valve (2P: white) CN604 :TL sensor (2P: white) CN500 : Bimetal thermostat (2P: blue) CN501 : High pressure switch (2P: green)</p> <div style="border: 1px solid black; padding: 5px; margin-top: 10px; text-align: center;"> <p>NOTE</p> <p>These connectors have a disconnect prevention mechanism: as such, the lock on their housing must be released before they are disconnected.</p> </div>	 <p>Connectors with locking mechanisms: as such, to disconnect them, they must be pressed in the direction of the arrow while pulling them out.</p> 
④	Control board assembly	<p>1. Remove the screws (ST2TØ4 × 10L 2 pcs.) fixing inverter box and P.C. board base.</p> <p>2. Remove the earth screw fixing inverter box and earth lead</p> <p>3. Remove the control board assembly from the P.C. board base. (Remove the heat sink and control board assembly while keeping them screwed together.)</p> <div style="border: 1px solid black; padding: 5px; margin-top: 10px; text-align: center;"> <p>NOTE</p> <p>Disengage the four claws of the P.C. board base, hold the heat sink, and lift to remove it.</p> </div> <p>4. Remove the two fixing screws used to secure the heat sink and control board assembly.</p> <div style="border: 1px solid black; padding: 5px; margin-top: 10px; text-align: center;"> <p>NOTE</p> <p>When mounting the new control board assembly, ensure that the P.C. board is inserted properly into the P.C. board base support groove.</p> </div>	 

No.	Part name	Procedure	Remarks
⑤	Side cabinet	<p>1. Side cabinet (right)</p> <ol style="list-style-type: none"> 1) Perform step 1 in ② and all the steps in ③. 2) Remove the fixing screw (ST2TØ4 × 10L 3 pcs.) used for securing the side cabinet (right) to the bottom plate and valve fixing panel. <p>2. Side cabinet (left)</p> <ol style="list-style-type: none"> 1) Perform step 1 in ②. 2) Remove the fixing screw (ST2TØ4 × 10L 3 pcs.) used for securing the side cabinet to the bottom plate and heat exchanger. 	   
⑥	Fan motor	<ol style="list-style-type: none"> 1) Perform step 1 in ② and all steps in ③. 2) Remove the flange nut fixing the fan motor and the propeller. <ul style="list-style-type: none"> • Flange nut is loosened by turning clockwise. (To tighten the flange nut, turn counterclockwise.) 3) Remove the propeller fan. 4) Disconnect the connector for fan motor from the inverter. 5) Remove the fixing screws (4 pcs.) holding by hands so that the fan motor does not fall. <p>* Precautions when assembling the fan motor Tighten the flange nut using a tightening torque of 4.9 N•m.</p>	

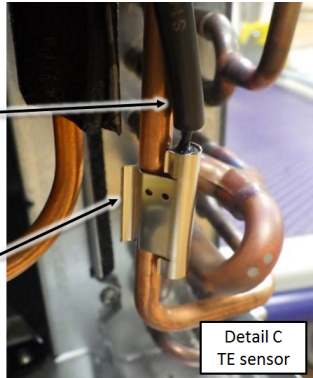
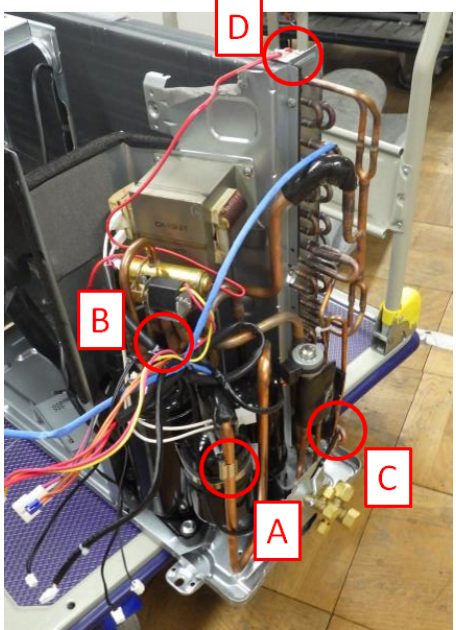
No.	Part name	Procedure	Remarks
⑦	Compressor	<ol style="list-style-type: none"> 1) Perform work of item 1 of ① and ②, ③, ④, ⑤. 2) Extract refrigerant gas. 3) Remove the partition plate. (ST2TØ4 × 10L 4 pcs.) 4) Remove the sound-insulation material. 5) Remove terminal cover of the compressor, and disconnect lead wire of the compressor from the terminal. <div style="border: 1px solid black; padding: 5px; margin: 10px 0;"> <p style="text-align: center;">NOTE</p> <p>Never reuse the compressor lead which you disconnected. Use the new one. If you reuse it, it may malfunction.</p> </div> <ol style="list-style-type: none"> 6) Remove pipe connected to the compressor with a burner. <ul style="list-style-type: none"> • Take care to keep the 4-way valve away from naked flames. (Otherwise, it may malfunction.) 7) Remove the fixing screw of the bottom plate and heat exchanger. (ST2TØ4 × 10L 1 pc.) 8) Remove the fixing screw of the bottom plate and valve fixing plate. (ST2TØ4 × 10L 2 pcs.) 9) Pull upward the refrigeration cycle. 10) Remove NUT (3 pcs.) fixing the compressor to the bottom plate. 	 <p>Partition board</p> <p>Compressor</p> <p>Valve fixing plate</p>
⑧	Reactor	<ol style="list-style-type: none"> 1) Perform work of item 1 of ②, and ③. 2) Remove screws fixing the reactors. (ST2TØ4 × 10L 2 pcs.) 	 <p>Partition plate</p> <p>Reactor</p>

No.	Part name	Procedure	Remarks
⑨	Electronic expansion valve coil	<p>1. Detachment</p> <ol style="list-style-type: none"> 1) Perform step 1 in ②, all the steps in ③ and 1 in ⑤. 2) Remove the coil by pulling it up from the electronic control valve body. <p>2. Attachment</p> <ol style="list-style-type: none"> 1) When assembling the coil into the valve body, ensure that the coil anti-turn lock is installed properly in the pipe. <p><Handling precaution> When handling the parts, do not pull the leads. When removing the coil from the valve body, use your hand to secure the body in order to prevent the pipe from being bent out of shape.</p>	 <p>Coil-PMV Body-PMV</p> <p>Rotate</p> <p>Body-PMV</p> <p>Hook</p> <p>Coil-PMV</p>
⑩	Fan guard	<p>1. Detachment</p> <ol style="list-style-type: none"> 1) Perform work of item 1 of ②. 2) Remove the front cabinet, and put it down so that fan guard side directs downward. <div data-bbox="453 1093 1023 1189" style="border: 1px solid black; padding: 5px; margin: 10px 0;"> <p>Perform work on a corrugated cardboard, cloth, etc. to prevent flaw to the product.</p> </div> <ol style="list-style-type: none"> 3) Remove the hooking claws by pushing minus screwdriver according to the arrow mark in the right figure, and remove the fan guard. <p>2. Attachment</p> <ol style="list-style-type: none"> 1) Insert claws of the fan guard in the holes of the front cabinet. Push the hooking claws (9 positions) by hands and fix the claws. <div data-bbox="453 1547 1023 1644" style="border: 1px solid black; padding: 5px; margin: 10px 0;"> <p>Check that all the hooking claws are fixed to the specified positions.</p> </div>	 <p>Minus screwdriver Front cabinet</p> <p>Hook</p>

No.	Part name	Procedure	Remarks
⑪	TE sensor (outdoor heat exchanging temperature sensor) • Attachment Install the sensor onto the straight pipe part of the condenser outlet pipe.		
⑫	TS sensor (Suction pipe temperature sensor) • Attachment Install the sensor onto the straight pipe part of the suction pipe. Be careful for the lead direction of the sensor.		
⑬	TD sensor (Discharge pipe temperature sensor) • Attachment Install the sensor onto the straight pipe part of the discharge pipe. Be careful for the lead direction of the sensor.		
⑭	TO sensor (Outside air temperature sensor) • Attachment Insert the outdoor air temperature sensor into the holder, and install the holder onto the heat exchanger.	 	
<p style="text-align: center;">CAUTION</p> <p>During the installation work (and on its completion), take care not to damage the coverings of the sensor leads on the edges of the metal plates or other parts. It is dangerous for these coverings to be damaged since damage may cause electric shocks and/or a fire.</p>			
<p style="text-align: center;">CAUTION</p> <p>After replacing the parts, check whether the positions where the sensors were installed are the proper positions as instructed. The product will not be controlled properly and trouble will result if the sensors have not been installed in their proper positions.</p>			

11. EXPLODED VIEWS AND PARTS LIST

11-1. RAV-GP561ATP*

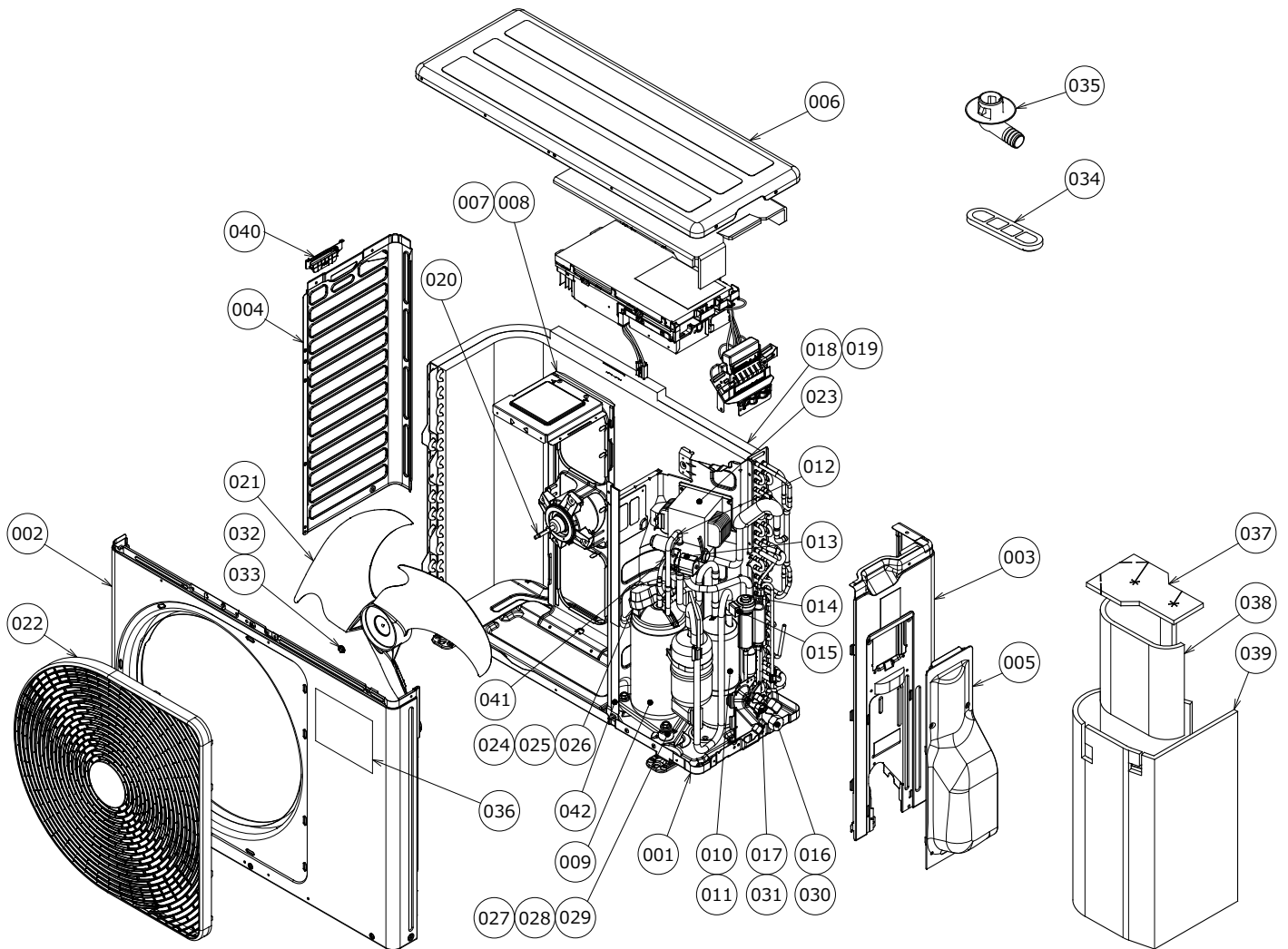

Location No.	Part No.	Description	RAV-		
			GP561ATP-E	GP561ATP-TR	GP561ATJP-E
001	43T42354	ASM-COAT-S-BASE	1	1	1
002	43T00745	ASM-CABI-F-S	1	1	1
003	43T00746	ASM-CABI-SIDE-R	1	1	1
004	43T00747	ASM-COAT-C-S-L	1	1	1
005	43T19352	ASM-COVER-PV	1	1	1
006	43T00748	ASM-CABI-U	1	1	1
007	43T39396	ASM-M-BASE	1	1	
008	43T39397	ASM-M-BASE			1
009	43T41541	COMP-ASSY	1	1	1
010	43T48302	ASM-ACCUM	1	1	
011	43T48303	ASM-ACCUM			1
012	43T46383	VALVE-4WAY	1	1	1
013	43T63352	COIL-V-4WAY	1	1	1
014	43T46469	BODY PMV	1	1	1
015	43T63360	COIL PMV	1	1	1
016	43T46427	VALVE;PACKED 12.7 DIA	1	1	1
017	43T46358	VALVE;PACKED 6.35 DIA	1	1	1
018	43T43595	ASM-WORK-COND	1	1	1
020	4302C119	MOTOR-FAN	1	1	1
021	43T20331	PROPELLER FAN	1	1	1
022	43T19371	FAN GUARD	1	1	1
023	43T58340	REACTOR	1	1	1
024	43T60439	ASM-COMP-LEAD	1	1	1
025	43T54319	BIMETAL-THERMO	1	1	1
026	43T50307	HOLDER-THERMO	1	1	1
027	43T47354	BOLT COMPRESSOR	1	1	
028	43T47413	BOLT COMPRESSOR			1
029	43T49335	RUBBER CUSHION	3	3	3
030	43T47405	BONNET, 12.7 DIA	1	1	1
031	43T47403	BONNET, 6.35 DIA	1	1	1
032	43T47001	NUT FLANGE	1	1	
033	43T39346	NUT FLANGE			1
034	43089160	CAP, WATERPROOF	2	2	2
035	43T79305	DRAIN NIPPLE	1	1	1
036	43T85529	MARK-T	1	1	1
037	43T04372	S-INSU(UP)	1	1	1
038	43T04355	SOUND INSULATION(IS)	1	1	1
039	43T04373	SOUND-INSU(OS)	1	1	1
040	43T19360	HANDLE	1	1	1
041	43T63359	SWITCH, PRESSURE	1	1	1
042	43T00749	ASM-PARTITION	1	1	1

<Inverter assembly>

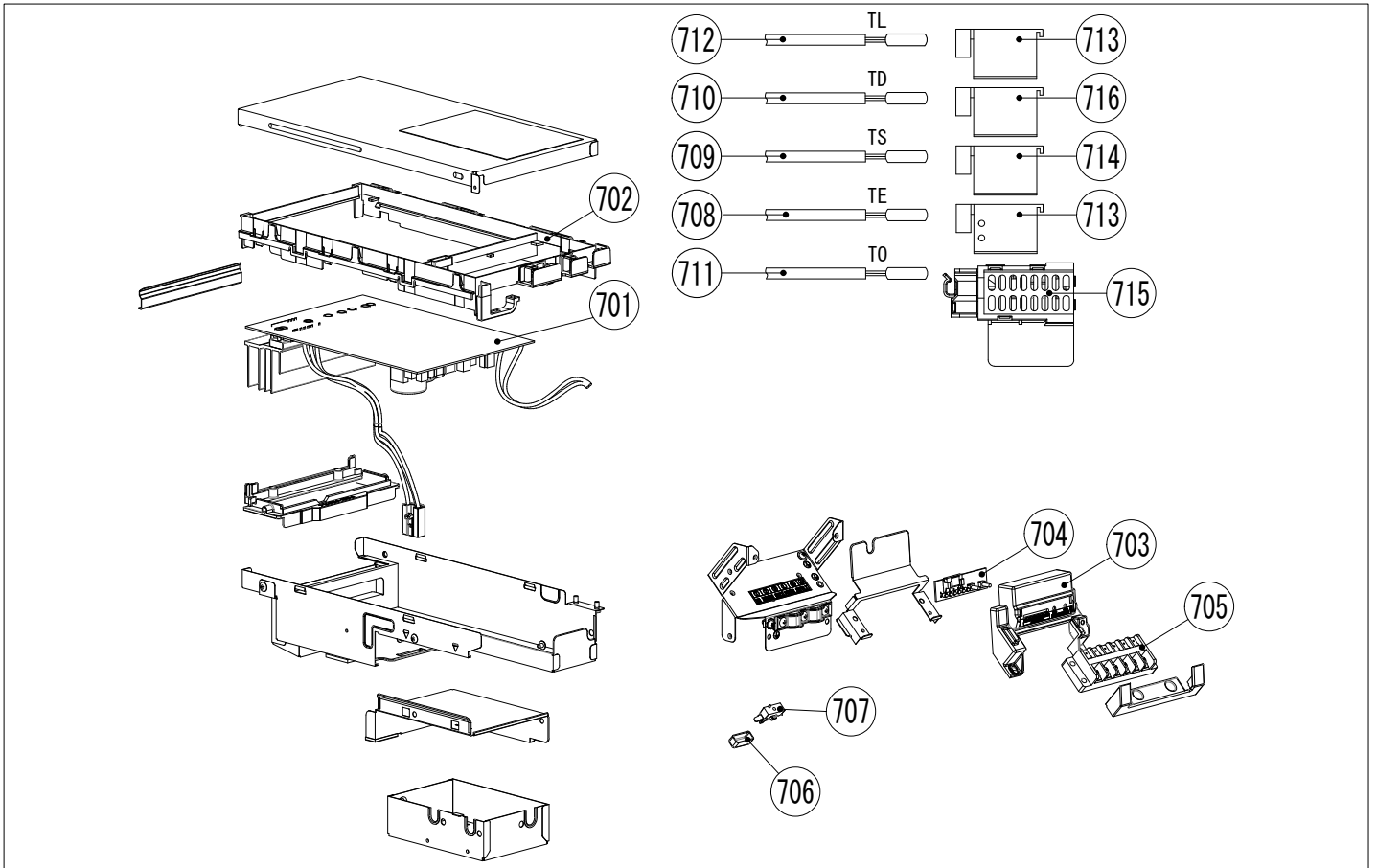

Location No.	Parts No	Description	RAV-
			GP561ATP*
701	43T6W694	PC BOARD ASSY	1
702	43T61325	BASE,PC BORAD	1
703	43T61320	BASE, PC BOARD	1
704	43T6V418	PC BOARD ASSY(MCC-1646)-LED	1
705	43T60423	SERV-TERMINAL	1
706	43T60426	FUSE	1
707	43T60425	FUSE HOLDER	1
708	43T50352	TEMPERATURE SENSOR (THAILAND)	1
709	43T50353	TEMPERATURE SENSOR (THAILAND)	1
710	43T50334	TEMPERATURE SENSOR)	1
711	43T50337	TEMPERATURE SENSOR,TO (Thailand)	1
712	43T50379	TEMPERATURE SENSOR(TL)	1
713	43T63318	HOLDER SENSOR	2
714	43T63323	HOLDER,SENSOR	1
715	43T63319	HOLDER,SENSOR	1
716	43T63317	HOLDER,SENSOR	1

WARNINGS ON REFRIGERANT LEAKAGE

Check of Concentration Limit

The room in which the air conditioner is to be installed requires a design that in the event of refrigerant gas leaking out, its concentration will not exceed a set limit.

The refrigerant R410A which is used in the air conditioner is safe, without the toxicity or combustibility of ammonia, and is not restricted by laws to be imposed which protect the ozone layer. However, since it contains more than air, it poses the risk of suffocation if its concentration should rise excessively. Suffocation from leakage of R410A is almost non-existent.

If a conditioner system is to be installed in a small room, select a suitable model and installation procedure so that if the refrigerant accidentally leaks out, its concentration does not reach the limit (and in the event of an emergency, measures can be made before injury can occur).

In a room where the concentration may exceed the limit, create an opening with adjacent rooms, or install mechanical ventilation combined with a gas leak detection device.

The concentration is as given below.

$$\frac{\text{Total amount of refrigerant (kg)}}{\text{Min. volume of the indoor unit installed room (m}^3\text{)}} \leq \text{Concentration limit (kg/m}^3\text{)}$$

The concentration limit of R410A which is used in air conditioners is 0.3kg/m³.

NOTE

The minimum indoor floor area compared with the amount of refrigerant is roughly as follows:
(When the ceiling is 2.7m high)

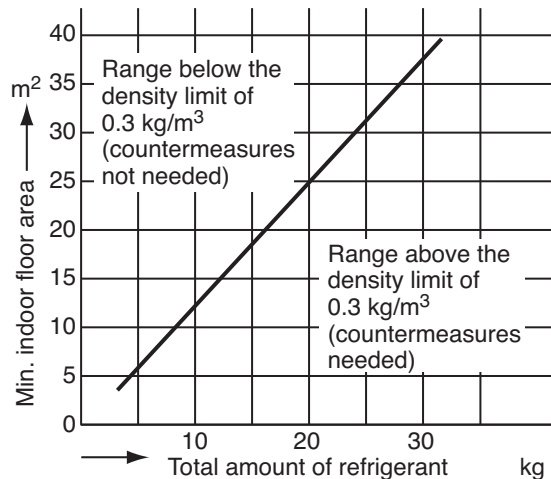

Toshiba Carrier (Thailand) Co., Ltd.

**144/9 MOO 5, BANGKADI INDUSTRIAL PARK, TIVANON ROAD, TAMBOL BANGKADI,
AMPHUR MUANG, PATHUMTHANI 12000, THAILAND.**