

TOSHIBA

SERVICE MANUAL

AIR TO WATER HEAT PUMP

SPLIT TYPE

Outdoor Unit

HWS-455H-E (TR)

Combination Hydro Unit

HWS-455XWHM3-E (TR)

CONTENTS

1. SAFETY PRECAUTIONS	3
2. SPECIFICATIONS	6
3. REFRIGERANT R410A	7
4. CONSTRUCTION VIEWS	15
5. WIRING DIAGRAM	16
6. SPECIFICATIONS OF ELECTRICAL PARTS	17
7. REFRIGERANT CYCLE DIAGRAM	18
8. CONTROL BLOCK DIAGRAM	20
9. OPERATION DESCRIPTION	21
10. INSTALLATION PROCEDURE	29
11. HOW TO DIAGNOSE THE TROUBLE	39
12. HOW TO REPLACE THE MAIN PARTS	48
13. EXPLODED VIEWS AND PARTS LIST	58

1. SAFETY PRECAUTIONS

Installing, starting up, and servicing air to water heat pump equipment can be hazardous due to system pressures, electrical components, and equipment location (roofs, elevated structures, etc.).

Only trained, qualified installers and service mechanics should install, start-up, and service this equipment.

Untrained personnel can perform basic maintenance functions such as cleaning coils. All other operations should be performed by trained service personnel.

When working on the equipment, observe precautions in the literature and on tags, stickers, and labels attached to the equipment.

Follow all safety codes, Wear safety glasses and work gloves. Keep quenching cloth and fire extinguisher near by when brazing. Use care in handling, rigging, and setting bulky equipment.

Read these instructions thoroughly and follow all warnings or cautions included in literature and attached to the unit. Consult local building codes and National Electrical Code (NEC) for special requirements. Recognize safety information. This is the safety-alert symbol . When you see this symbol on the unit and in instructions or manuals, be alert to the potential for personal injury. Understand these signal words : DANGER, WARNING, and CAUTION. These words are used with the safety-alert symbol.

DANGER identifies the most serious hazards which will result in severe personal injury or death. WARNING signifies hazards which could result in personal injury or death. CAUTION is used to identify unsafe practices which may result in minor personal injury or product and property damage. NOTE is used to highlight suggestions which will result in enhanced installation, reliability, or operation.

- Before installation, please read these precautions for safety carefully.
 - Be sure to follow the precautions provided here to avoid safety risks. The symbols and their meanings are shown below.
- WARNING** : It indicates that incorrect use of this unit may cause severe injury or death.
- CAUTION** : FAILURE TO FOLLOW THIS CAUTION may result in equipment damage or improper operation and personal injury.

CAUTION

New refrigerant air to water heat pump installation

- **THIS AIR TO WATER HEAT PUMP USES THE NEW HFC REFRIGERANT (R410A), WHICH DOES NOT DESTROY THE OZONE LAYER.**

R410A refrigerant is affected by impurities such as water and oils because the pressure of R410A refrigerant is approx. 1.6 times of refrigerant R22.

ALSO NEW OILS ARE USED WITH R410A, THUS ALWAYS USE NEW REFRIGERANT PIPING AND DO NOT ALLOW MOISTURE OR DUST TO ENTER THE SYSTEM.

To avoid mixing refrigerant and refrigerant machine oil, the sizes of charging port on the main unit is different than those used on R22 machines and different tools will be required.

- **EQUIPMENT DAMAGE HAZARD**

Failure to follow this caution may result in equipment damage or improper operation.

Do not bury more than 36 in. (914 mm) of refrigerant pipe in the ground. If any section of pipe is buried, there must be a 6 in. (152 mm) vertical rise to the valve connections on the outdoor units. If more than the recommended length is buried, refrigerant may migrate to the cooler buried section during extended periods of system shutdown. This causes refrigerant slugging and could possibly damage the compressor at start-up.

DANGER

- FOR USE BY QUALIFIED PERSONS ONLY.
- TURN OFF MAIN POWER SUPPLY BEFORE ATTEMPTING ANY ELECTRICAL WORK. MAKE SURE ALL POWER SWITCHES ARE OFF. FAILURE TO DO SO MAY CAUSE ELECTRIC SHOCK.
- CONNECT THE CONNECTING CABLE CORRECTLY. IF THE CONNECTING CABLE IS CONNECTED WRONGLY, ELECTRIC PARTS MAY BE DAMAGED.
- CHECK THE EARTH WIRE THAT IT IS NOT BROKEN OR DISCONNECTED BEFORE INSTALLATION.
- DO NOT INSTALL NEAR CONCENTRATIONS OF COMBUSTIBLE GAS OR GAS VAPORS. FAILURE TO FOLLOW THIS INSTRUCTION CAN RESULT IN FIRE OR EXPLOSION.
- TO PREVENT OVERHEATING THE HYDRO UNIT AND CAUSING A FIRE HAZARD, PLACE THE UNIT WELL AWAY (MORE THAN 2 M) FROM HEAT SOURCES SUCH AS RADIATORS, HEATERS, FURNACE, STOVES, ETC.
- WHEN MOVING THE AIR TO WATER HEAT PUMP FOR INSTALLING IT IN ANOTHER PLACE AGAIN, BE VERY CAREFUL NOT TO GET THE SPECIFIED REFRIGERANT (R410A) WITH ANY OTHER GASEOUS BODY INTO THE REFRIGERATION CYCLE. IF AIR OR ANY OTHER GAS IS MIXED IN THE REFRIGERANT, THE GAS PRESSURE IN THE REFRIGERATION CYCLE BECOMES ABNORMALLY HIGH AND IT RESULTINGLY CAUSES BURST OF THE PIPE AND INJURIES ON PERSONS.
- IN THE EVENT THAT THE REFRIGERANT LEAK, DURING INSTALLATION WORK, IMMEDIATELY ALLOW FRESH AIR INTO THE ROOM. IF THE REFRIGERANT GAS IS HEATED BY FIRE OR SOMETHING ELSE, IT CAUSE GENERATION OF POISONOUS GAS.

WARNING

- **ELECTRICAL SHOCK HAZARD**

Failure to follow this warning could result in personal injury or death.

Before installing, modifying, or servicing system, main electrical disconnect switch must be in the OFF position. There may be more than 1 disconnect switch. Lock out and tag switch with a suitable warning label.

- Never modify this unit by removing any of the safety guards or bypassing any of the safety interlock switches.
- Installation work must be performed by qualified personnel only.
- Specified tools and pipe parts for model R410A are required, and installation work must be done in accordance with the manual. HFC type refrigerant R410A has 1.6 times more pressure than that of conventional refrigerant (R22). Use the specified pipe parts, and ensure correct installation, otherwise damage and/or injury may be caused. At the same time, water leakage, electrical shock, and fire may occur.
- Be sure to install the unit in a place which can sufficiently bear its weight. If the load bearing of the unit is not enough, or installation of the unit is improper, the unit may fall and result in injury.
- Electrical work must be performed by trained, qualified installers and service mechanics in accordance with the code governing such installation work, internal wiring regulations, and the manual. A dedicated circuit and the rated voltage must be used. Insufficient power supply or improper installation may cause electrical shock or fire.
- Use a cabletyre cable to connect wires in the hydro/outdoor units. Midway connection is not allowed. Improper connection or fixing may cause a fire.
- Wiring between the hydro unit and outdoor units must be well shaped so that the cover can be firmly placed. Improper cover installation may cause increased heat, fire, or electrical shock at the terminal area.
- Be sure to use only approved accessories or the specified parts. Failure to do so may cause the unit to fall, water leakage, fire or electrical shock.
- After the installation work, ensure that there is no leakage of refrigerant gas. If the refrigerant gas leaks out of the pipe into the room and is heated by fire or something else from a fan heater, stove or gas range, it causes generation of poisonous gas.
- Make sure the equipment is properly grounded. Do not connect the ground wire to a gas pipe, water pipe, lightning conductor, or telephone earth wire. Improper earth work may be the cause of electrical shock.
- Do not install the unit where flammable gas may leak. If there is any gas leakage or accumulation around the unit, it can cause a fire.
- Do not select a location for installation where there may be excessive water or humidity, such as a bathroom. Deterioration of insulation may cause electrical shock or fire.
- Installation work must be performed following the instructions in this installation manual. Improper installation may cause water leakage, electrical shock or fire. Check the following items before operating the unit.
 - Be sure that the pipe connection is well placed and there are no leaks.
 - Check that the service valve is open. If the service valve is closed, it may cause overpressure and result in compressor damage. At the same time, if there is a leak in the connection part, it may cause air suction and overpressure, resulting in damage to the unit or injury.
- In a pump-down operation, be sure to stop the compressor unit before removing the refrigerant pipe. If removing the refrigerant pipe while the compressor is operating with the service valve opened, it may cause air suction and overpressure, resulting in damage to the unit or injury.
- Do not modify the power cable, connect the cable midway, or use a multiple outlet extension cable. Doing so may cause contact failure, insulation failure, or excess current, resulting in fire or electrical shock.
- If you detect any damage, do not install the unit. Contact your dealer immediately.

CAUTION

- Exposure of unit to water or other moisture before installation could result in electric shock. Do not store it in a wet basement or expose to rain or water.
- After unpacking the unit, examine it carefully for possible damage. Report any damages to your distributor.
- Do not install in a place that can increase the vibration of the unit. Do not install in a place that can amplify the noise level of the unit or where noise and discharged air might disturb neighbors.
- Please read this installation manual carefully before installing the unit. It contains further important instructions for proper installation.
- This appliance must be connected to the main power supply by means of a circuit breaker depending on the place where the unit is installed. Failure to do so may cause electrical shock.
- Follow the instructions in this installation manual to arrange the drain pipe for proper drainage from the unit. Ensure that drained water is discharged. Improper drainage can result in water leakage, causing water damage to furniture.
- Tighten the flare nut with a torque wrench using the prescribed method. Do not apply excess torque. Otherwise, the nut may crack after a long period of usage and it may cause the leakage of refrigerant.
- Wear gloves (heavy gloves such as cotton gloves) for installation work. Failure to do so may cause personal injury when handling parts with sharp edges.
- Do not touch the air intake section or the aluminum fins of the outdoor unit. It may cause injury.
- Do not install the outdoor unit in a place which can be a nest for small animals. Small animals could enter and contact internal electrical parts, causing a failure or fire.
- Request the user to keep the place around the unit tidy and clean.
- Make sure to conduct a trial operation after the installation work, and explain how to use and maintain the unit to the customer in accordance with the manual. Ask the customer to keep the operation manual along with the installation manual.

2. SPECIFICATIONS

Outdoor Unit

Unit model	Outdoor		HWS-455H-E
Cooling capacity		(kW)	4.50
Heating capacity		(kW)	4.50
Power supply	1 Ph, 220-230V, 50Hz		
Operating noise	Outdoor		(dB-A) 65
Outdoor unit	Dimension	Height	(mm) 630
		Width	(mm) 800
		Depth	(mm) 300
	Net weight		(kg) 42
	Compressor	Motor output	(W) 1100
		Type	Twin rotary type with DC-inverter variablespeed control
		Model	DA150A1T-21F
	Fan motor output		(W) 43
Piping connection	Type		Flare connection
	Hydro unit	Liquid side	(mm) \varnothing 6.35
		Gas side	(mm) \varnothing 12.7
	Outdoor unit	Liquid side	(mm) \varnothing 6.35
		Gas side	(mm) \varnothing 12.7
	Minimum length		(m) 5
	Maximum length		(m) 15
	Maximum chargeless length		(m) 15
	Maximum height difference		(m) 10
Refrigerant	Name of refrigerant		R410A
	Weight		(kg) 1.15
Wiring connection	Power supply		3Wires:includes earth (Outdoor)
	Interconnection		4Wires:includes earth
Usable temperature range	Hydro	(Cooling/Heating/Hot water) (°C)	5-32 / 5-32 / 5-32
	Outdoor	(Cooling/Heating/Hot water) (°C)	10-43 / -20-25 / -20-43
Accessory	Outdoor unit	Drain nipple	1
		Water-proof rubber cap	2

3. REFRIGERANT R410A

This air to water heat pump adopts the new refrigerant HFC (R410A) which does not damage the ozone layer.

The working pressure of the new refrigerant R410A is 1.6 times higher than conventional refrigerant (R22). The refrigerating oil is also changed in accordance with change of refrigerant, so be careful that water, dust, and existing refrigerant or refrigerating oil are not entered in the refrigerant cycle of the air to water heat pump using the new refrigerant during installation work or servicing time.

The next section describes the precautions for air to water heat pump using the new refrigerant. Conforming to contents of the next section together with the general cautions included in this manual, perform the correct and safe work.

3-1. Safety During Installation/Serviceing

As R410A's pressure is about 1.6 times higher than that of R22, improper installation/serviceing may cause a serious trouble. By using tools and materials exclusive for R410A, it is necessary to carry out installation/serviceing safely while taking the following precautions into consideration.

1. Never use refrigerant other than R410A in an air to water heat pump which is designed to operate with R410A.
If other refrigerant than R410A is mixed, pressure in the refrigeration cycle becomes abnormally high, and it may cause personal injury, etc. by a rupture.
2. Confirm the used refrigerant name, and use tools and materials exclusive for the refrigerant R410A. The refrigerant name R410A is indicated on the visible place of the outdoor unit of the air to water heat pump using R410A as refrigerant.
To prevent mischarging, the diameter of the service port differs from that of R22.
3. If a refrigeration gas leakage occurs during installation/serviceing, be sure to ventilate fully.
If the refrigerant gas comes into contact with fire, a poisonous gas may occur.
4. When installing or removing an air to water heat pump, do not allow air or moisture to remain in the refrigeration cycle. Otherwise, pressure in the refrigeration cycle may become abnormally high so that a rupture or personal injury may be caused.
5. After completion of installation work, check to make sure that there is no refrigeration gas leakage.
If the refrigerant gas leaks into the room, coming into contact with fire in the fan-driven heater, space heater, etc., a poisonous gas may occur.

6. When an air to water heat pump system charged with a large volume of refrigerant is installed in a small room, it is necessary to exercise care so that, even when refrigerant leaks, its concentration does not exceed the marginal level.
If the refrigerant gas leakage occurs and its concentration exceeds the marginal level, an oxygen starvation accident may result.
7. Be sure to carry out installation or removal according to the installation manual.
Improper installation may cause refrigeration trouble, water leakage, electric shock, fire, etc.
8. Unauthorized modifications to the air to water heat pump may be dangerous. If a breakdown occurs please call a qualified air to water heat pump technician or electrician.
Improper repair's may result in water leakage, electric shock and fire, etc.

3-2. Refrigerant Piping Installation

3-2-1. Piping Materials and Joints Used

For the refrigerant piping installation, copper pipes and joints are mainly used. Copper pipes and joints suitable for the refrigerant must be chosen and installed. Furthermore, it is necessary to use clean copper pipes and joints whose interior surfaces are less affected by contaminants.

1. Copper Pipes

It is necessary to use seamless copper pipes which are made of either copper or copper alloy and it is desirable that the amount of residual oil is less than 40 mg/10 m. Do not use copper pipes having a collapsed, deformed or discolored portion (especially on the interior surface).

Otherwise, the expansion valve or capillary tube may become blocked with contaminants.

As an air to water heat pump using R410A incurs pressure higher than when using R22, it is necessary to choose adequate materials.

Thicknesses of copper pipes used with R410A are as shown in Table 3-2-1. Never use copper pipes thinner than 0.8 mm even when it is available on the market.

Table 3-2-1 Thicknesses of annealed copper pipes

		Thickness (mm)	
Nominal diameter	Outer diameter (mm)	R410A	R22
1/4	6.35	0.80	0.80
3/8	9.52	0.80	0.80
1/2	12.70	0.80	0.80
5/8	15.88	1.00	1.00

2. Joints

For copper pipes, flare joints or socket joints are used. Prior to use, be sure to remove all contaminants.

a) Flare Joints

Flare joints used to connect the copper pipes cannot be used for pipings whose outer diameter exceeds 20 mm. In such a case, socket joints can be used.

Sizes of flare pipe ends, flare joint ends and flare nuts are as shown in Tables 3-2-3 to 3-2-6 below.

b) Socket Joints

Socket joints are such that they are brazed for connections, and used mainly for thick pipings whose diameter is larger than 20 mm.

Thicknesses of socket joints are as shown in Table 3-2-2.

Table 3-2-2 Minimum thicknesses of socket joints

Nominal diameter	Reference outer diameter of copper pipe jointed (mm)	Minimum joint thickness (mm)
1/4	6.35	0.50
3/8	9.52	0.60
1/2	12.70	0.70
5/8	15.88	0.80

3-2-2. Processing of Piping Materials

When performing the refrigerant piping installation, care should be taken to ensure that water or dust does not enter the pipe interior, that no other oil than lubricating oils used in the installed air-water heat pump is used, and that refrigerant does not leak. When using lubricating oils in the piping processing, use such lubricating oils whose water content has been removed. When stored, be sure to seal the container with an airtight cap or any other cover.

1. Flare processing procedures and precautions

a) Cutting the Pipe

By means of a pipe cutter, slowly cut the pipe so that it is not deformed.

b) Removing Burrs and Chips

If the flared section has chips or burrs, refrigerant leakage may occur.

Carefully remove all burrs and clean the cut surface before installation.

c) Insertion of Flare Nut

d) Flare Processing

Make certain that a clamp bar and copper pipe have been cleaned.

By means of the clamp bar, perform the flare processing correctly.

Use either a flare tool for R410A or conventional flare tool.

Flare processing dimensions differ according to the type of flare tool. When using a conventional flare tool, be sure to secure "dimension A" by using a gauge for size adjustment.

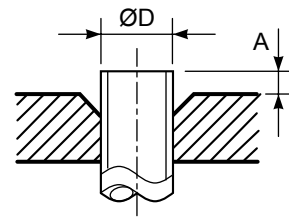

Fig. 3-2-1 Flare processing dimensions

Table 3-2-3 Dimensions related to flare processing for R410A

Nominal diameter	Outer diameter (mm)	Thickness (mm)	A (mm)		
			Flare tool for R410A clutch type	Conventional flare tool	
				Clutch type	Wing nut type
1/4	6.35	0.8	0 to 0.5	1.0 to 1.5	1.5 to 2.0
3/8	9.52	0.8	0 to 0.5	1.0 to 1.5	1.5 to 2.0
1/2	12.70	0.8	0 to 0.5	1.0 to 1.5	2.0 to 2.5
5/8	15.88	1.0	0 to 0.5	1.0 to 1.5	2.0 to 2.5

Table 3-2-4 Dimensions related to flare processing for R22

Nominal diameter	Outer diameter (mm)	Thickness (mm)	A (mm)		
			Flare tool for R22 clutch type	Conventional flare tool	
				Clutch type	Wing nut type
1/4	6.35	0.8	0 to 0.5	0.5 to 1.0	1.0 to 1.5
3/8	9.52	0.8	0 to 0.5	0.5 to 1.0	1.0 to 1.5
1/2	12.70	0.8	0 to 0.5	0.5 to 1.0	1.5 to 2.0
5/8	15.88	1.0	0 to 0.5	0.5 to 1.0	1.5 to 2.0

Table 3-2-5 Flare and flare nut dimensions for R410A

Nominal diameter	Outer diameter (mm)	Thickness (mm)	Dimension (mm)				Flare nut width (mm)
			A	B	C	D	
1/4	6.35	0.8	9.1	9.2	6.5	13	17
3/8	9.52	0.8	13.2	13.5	9.7	20	22
1/2	12.70	0.8	16.6	16.0	12.9	23	26
5/8	15.88	1.0	19.7	19.0	16.0	25	29

Table 3-2-6 Flare and flare nut dimensions for R22

Nominal diameter	Outer diameter (mm)	Thickness (mm)	Dimension (mm)				Flare nut width (mm)
			A	B	C	D	
1/4	6.35	0.8	9.0	9.2	6.5	13	17
3/8	9.52	0.8	13.0	13.5	9.7	20	22
1/2	12.70	0.8	16.2	16.0	12.9	20	24
5/8	15.88	1.0	19.7	19.0	16.0	23	27
3/4	19.05	1.0	23.3	24.0	19.2	34	36

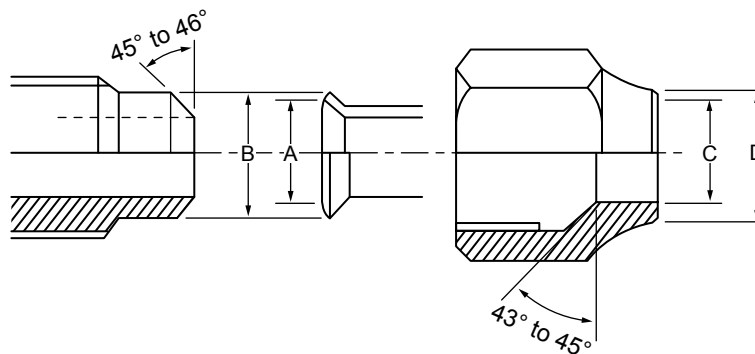

Fig. 3-2-2 Relations between flare nut and flare seal surface

2. Flare Connecting Procedures and Precautions

- Make sure that the flare and union portions do not have any scar or dust, etc.
- Correctly align the processed flare surface with the union axis.
- Tighten the flare with designated torque by means of a torque wrench. The tightening torque for R410A is the same as that for conventional R22. Incidentally, when the torque is weak, the gas leakage may occur. When it is strong, the flare nut may crack and may be made non-removable. When choosing the tightening torque, comply with values designated by manufacturers. Table 3-2-7 shows reference values.

NOTE :

When applying oil to the flare surface, be sure to use oil designated by the manufacturer. If any other oil is used, the lubricating oils may deteriorate and cause the compressor to burn out.

Table 3-2-7 Tightening torque of flare for R410A [Reference values]

Nominal diameter	Outer diameter (mm)	Tightening torque N•m (kgf•cm)	Tightening torque of torque wrenches available on the market N•m (kgf•cm)
1/4	6.35	14 to 18 (140 to 180)	16 (160), 18 (180)
3/8	9.52	33 to 42 (330 to 420)	42 (420)
1/2	12.70	50 to 62 (500 to 620)	55 (550)
5/8	15.88	63 to 77 (630 to 770)	65 (650)

3-3. Tools

3-3-1. Required Tools

The service port diameter of packed valve of the outdoor unit in the air-water heat pump using R410A is changed to prevent mixing of other refrigerant. To reinforce the pressure-resisting strength, flare processing dimensions and opposite side dimension of flare nut (For Ø12.7 copper pipe) of the refrigerant piping are lengthened.

The used refrigerating oil is changed, and mixing of oil may cause a trouble such as generation of sludge, clogging of capillary, etc. Accordingly, the tools to be used are classified into the following three types.

1. Tools exclusive for R410A (Those which cannot be used for conventional refrigerant (R22))
2. Tools exclusive for R410A, but can be also used for conventional refrigerant (R22)
3. Tools commonly used for R410A and for conventional refrigerant (R22)

The table below shows the tools exclusive for R410A and their interchangeability.

Tools exclusive for R410A (The following tools for R410A are required.)

Tools whose specifications are changed for R410A and their interchangeability

No.	Used tool	Usage	R410A air-water heat pump installation		Conventional air-water heat pump installation
			Existence of new equipment for R410A	Whether conventional equipment can be used	Whether new equipment can be used with conventional refrigerant
1	Flare tool	Pipe flaring	Yes	*(Note 1)	○
2	Copper pipe gauge for adjusting projection margin	Flaring by conventional flare tool	Yes	*(Note 1)	*(Note 1)
3	Torque wrench (For Ø12.7)	Connection of flare nut	Yes	×	×
4	Gauge manifold	Evacuating, refrigerant charge, run check, etc.	Yes	×	×
5	Charge hose				
6	Vacuum pump adapter	Vacuum evacuating	Yes	×	○
7	Electronic balance for refrigerant charging	Refrigerant charge	Yes	×	○
8	Refrigerant cylinder	Refrigerant charge	Yes	×	×
9	Leakage detector	Gas leakage check	Yes	×	○
10	Charging cylinder	Refrigerant charge	(Note 2)	×	×

(Note 1) When flaring is carried out for R410A using the conventional flare tools, adjustment of projection margin is necessary. For this adjustment, a copper pipe gauge, etc. are necessary.

(Note 2) Charging cylinder for R410A is being currently developed.

General tools (Conventional tools can be used.)

In addition to the above exclusive tools, the following equipments which serve also for R22 are necessary as the general tools.

- | | | |
|---|-----------------------------|--|
| 1. Vacuum pump
Use vacuum pump by attaching vacuum pump adapter. | 4. Reamer | 9. Hole core drill (Ø65) |
| 2. Torque wrench (For Ø6.35, Ø9.52) | 5. Pipe bender | 10. Hexagon wrench (Opposite side 4mm) |
| 3. Pipe cutter | 6. Level vial | 11. Tape measure |
| | 7. Screwdriver (+, -) | 12. Metal saw |
| | 8. Spanner or Monkey wrench | |

Also prepare the following equipments for other installation method and run check.

- | | |
|----------------|---------------------------------|
| 1. Clamp meter | 3. Insulation resistance tester |
| 2. Thermometer | 4. Electroscopes |

3-4. Recharging of Refrigerant

When it is necessary to recharge refrigerant, charge the specified amount of new refrigerant according to the following steps.

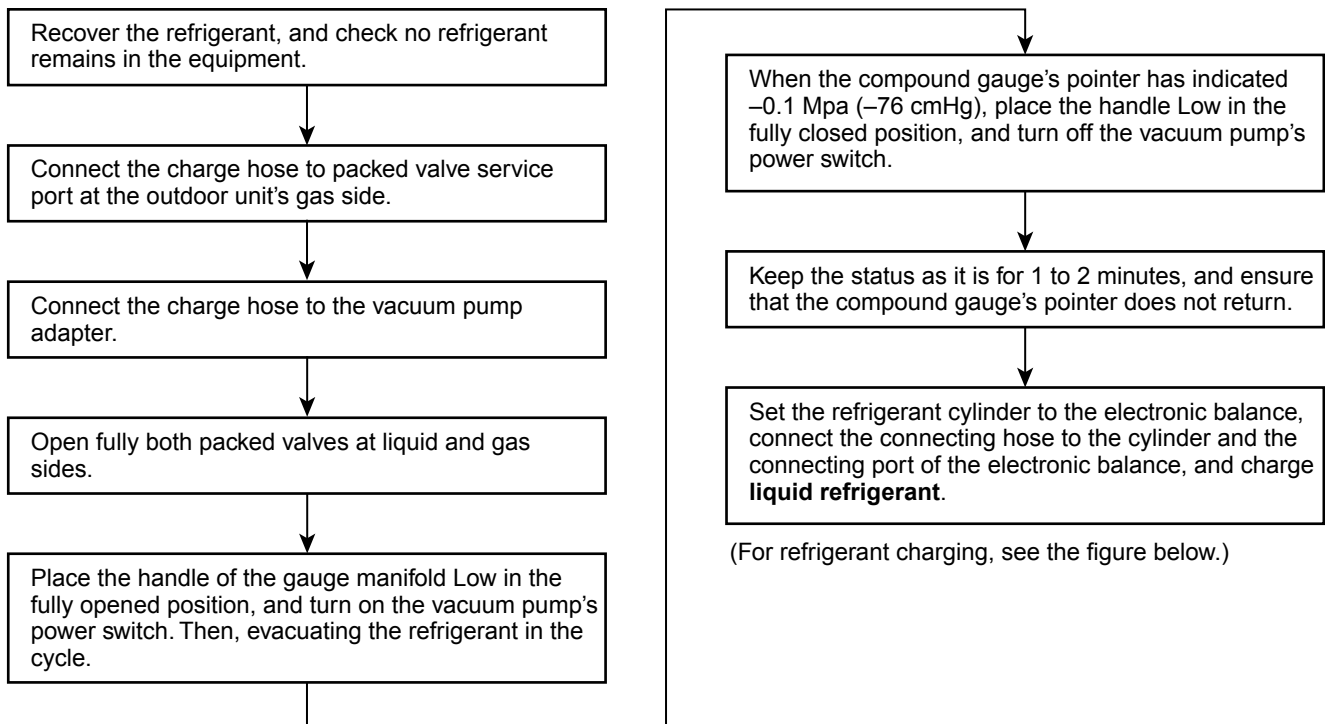

1. Never charge refrigerant exceeding the specified amount.
2. If the specified amount of refrigerant cannot be charged, charge refrigerant **bit by bit** in COOL mode.
3. Do not carry out additional charging.

When additional charging is carried out if refrigerant leaks, the refrigerant composition changes in the refrigeration cycle, that is characteristics of the air to water heat pump changes, refrigerant exceeding the specified amount is charged, and working pressure in the refrigeration cycle becomes abnormally high pressure, and may cause a rupture or personal injury.

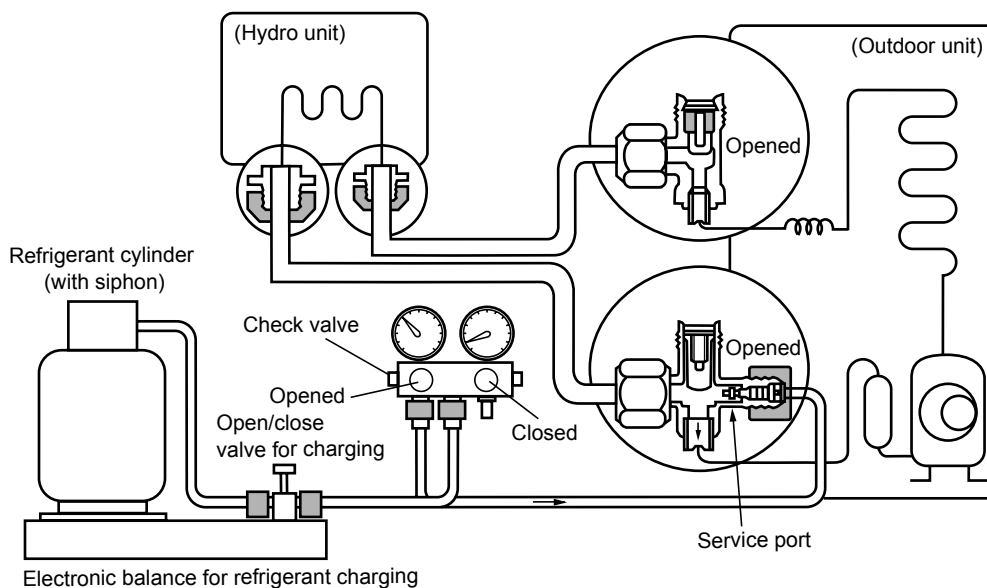
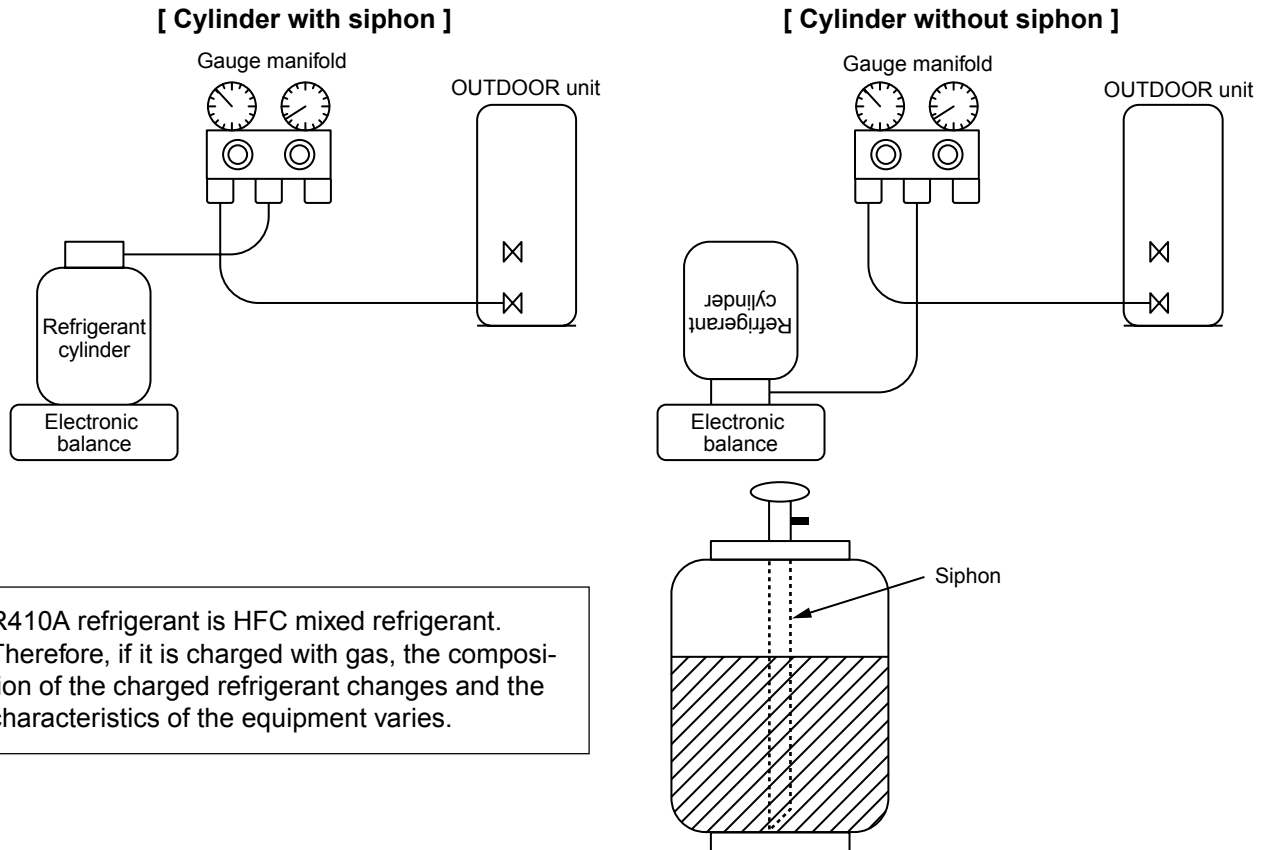

Fig. 3-4-1 Configuration of refrigerant charging

1. Be sure to make setting so that **liquid** can be charged.
2. When using a cylinder equipped with a siphon, liquid can be charged without turning it upside down.

It is necessary for charging refrigerant under condition of liquid because R410A is mixed type of refrigerant. Accordingly, when charging refrigerant from the refrigerant cylinder to the equipment, charge it turning the cylinder upside down if cylinder is not equipped with siphon.



R410A refrigerant is HFC mixed refrigerant. Therefore, if it is charged with gas, the composition of the charged refrigerant changes and the characteristics of the equipment varies.

Fig. 3-4-2

3-5. Brazing of Pipes

3-5-1. Materials for Brazing

1. Silver brazing filler

Silver brazing filler is an alloy mainly composed of silver and copper. It is used to join iron, copper or copper alloy, and is relatively expensive though it excels in solderability.

2. Phosphor bronze brazing filler

Phosphor bronze brazing filler is generally used to join copper or copper alloy.

3. Low temperature brazing filler

Low temperature brazing filler is generally called solder, and is an alloy of tin and lead. Since it is weak in adhesive strength, do not use it for refrigerant pipes.

1. Phosphor bronze brazing filler tends to react with sulfur and produce a fragile compound water solution, which may cause a gas leakage. Therefore, use any other type of brazing filler at a hot spring resort, etc., and coat the surface with a paint.
2. When performing brazing again at time of servicing, use the same type of brazing filler.

3-5-2. Flux

1. Reason why flux is necessary

- By removing the oxide film and any foreign matter on the metal surface, it assists the flow of brazing filler.
- In the brazing process, it prevents the metal surface from being oxidized.
- By reducing the brazing filler's surface tension, the brazing filler adheres better to the treated metal.

2. Characteristics required for flux

- Activated temperature of flux coincides with the brazing temperature.
- Due to a wide effective temperature range, flux is hard to carbonize.
- It is easy to remove slag after brazing.
- The corrosive action to the treated metal and brazing filler is minimum.
- It excels in coating performance and is harmless to the human body.

As the flux works in a complicated manner as described above, it is necessary to select an adequate type of flux according to the type and shape of treated metal, type of brazing filler and brazing method, etc.

3. Types of flux

• **Noncorrosive flux**

Generally, it is a compound of borax and boric acid.

It is effective in case where the brazing temperature is higher than 800°C.

• **Activated flux**

Most of fluxes generally used for silver brazing are this type.

It features an increased oxide film removing capability due to the addition of compounds such as potassium fluoride, potassium chloride and sodium fluoride to the borax-boric acid compound.

4. Piping materials for brazing and used brazing filler/flux

Piping material	Used brazing filler	Used flux
Copper - Copper	Phosphor copper	Do not use
Copper - Iron	Silver	Paste flux
Iron - Iron	Silver	Vapor flux

1. Do not enter flux into the refrigeration cycle.
2. When chlorine contained in the flux remains within the pipe, the lubricating oil deteriorates. Therefore, use a flux which does not contain chlorine.
3. When adding water to the flux, use water which does not contain chlorine (e.g. distilled water or ion-exchange water).
4. Remove the flux after brazing.

3-5-3. Brazing

As brazing work requires sophisticated techniques, experiences based upon a theoretical knowledge, it must be performed by a person qualified.

In order to prevent the oxide film from occurring in the pipe interior during brazing, it is effective to proceed with brazing while letting dry Nitrogen gas (N₂) flow.

Never use gas other than Nitrogen gas.

1. Brazing method to prevent oxidation

- 1) Attach a reducing valve and a flow-meter to the Nitrogen gas cylinder.
- 2) Use a copper pipe to direct the piping material, and attach a flow-meter to the cylinder.
- 3) Apply a seal onto the clearance between the piping material and inserted copper pipe for Nitrogen in order to prevent backflow of the Nitrogen gas.
- 4) When the Nitrogen gas is flowing, be sure to keep the piping end open.
- 5) Adjust the flow rate of Nitrogen gas so that it is lower than 0.05 m³/Hr or 0.02 MPa (0.2kgf/cm²) by means of the reducing valve.
- 6) After performing the steps above, keep the Nitrogen gas flowing until the pipe cools down to a certain extent (temperature at which pipes are touchable with hands).
- 7) Remove the flux completely after brazing.

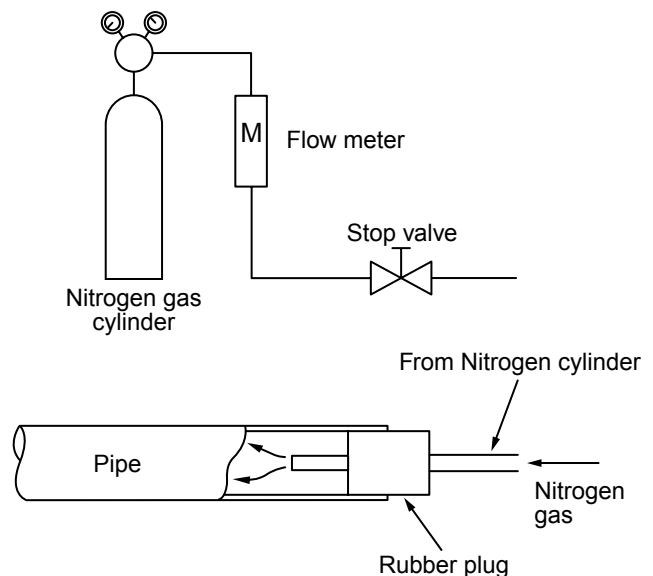
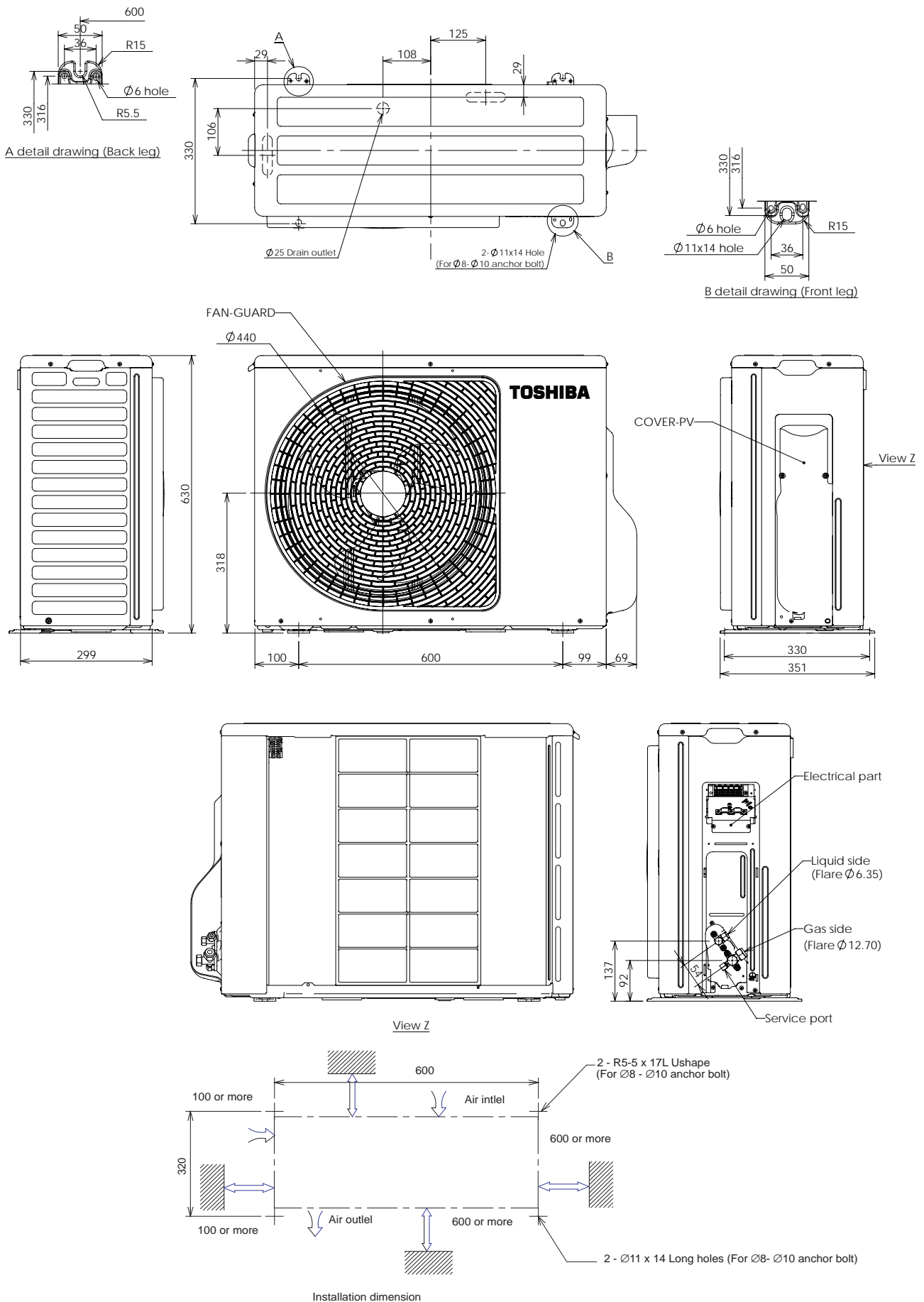

Fig. 3-5-1 Prevention of oxidation during brazing

4. CONSTRUCTION VIEWS

Outdoor Unit



5. WIRING DIAGRAM

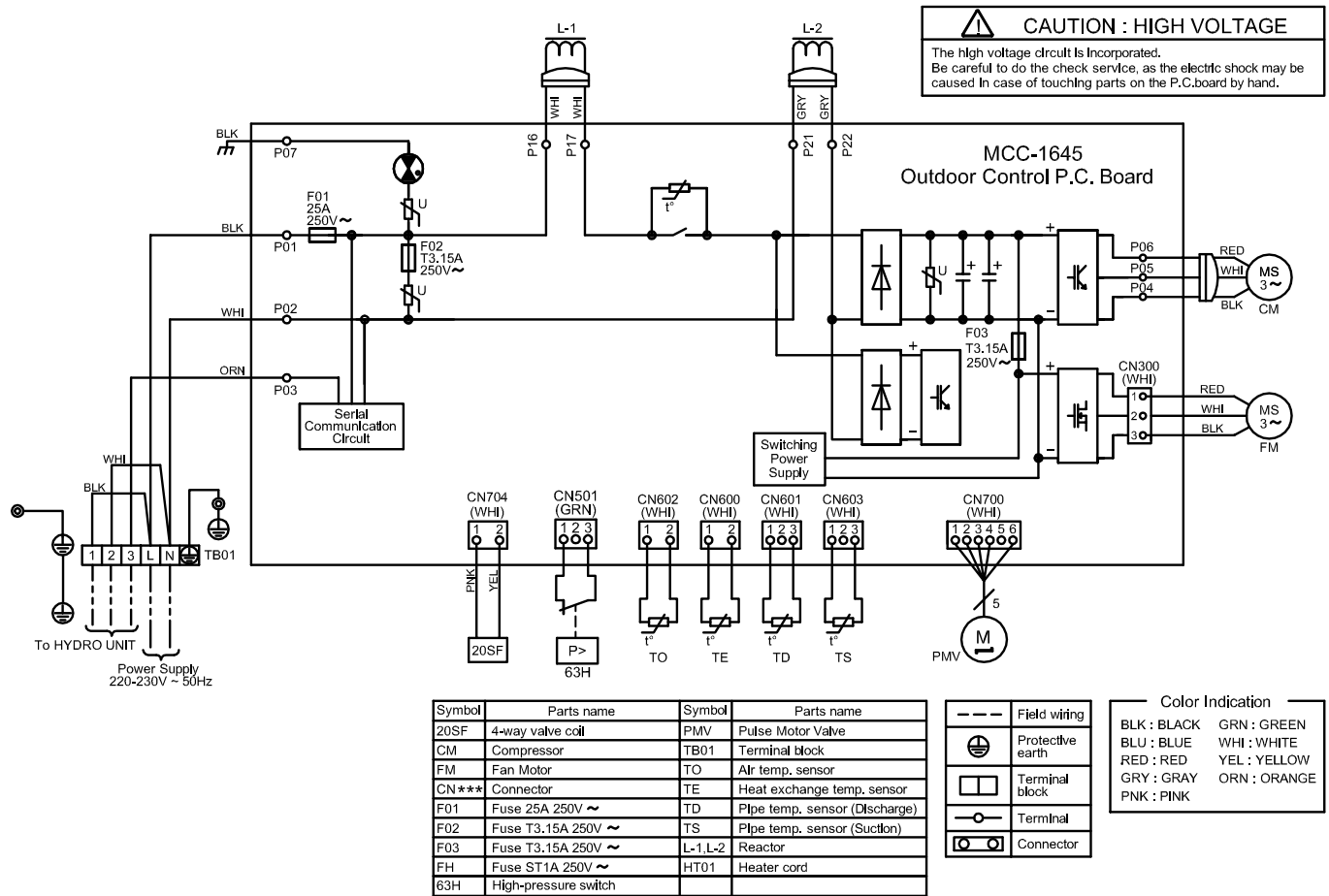

6. SPECIFICATIONS OF ELECTRICAL PARTS

Outdoor Unit

No.	Parts name	Model name	Rating
1	Reactor	CH-57-Z-T ; R	L = 10mH, 16A
2	Outdoor fan motor	ICF-140-43-4R	DC140V, 43W
3	Suction temp. sensor (TS sensor)	(Inverter attached)	10k Ω (25°C)
4	Discharge temp. sensor (TD sensor)	(Inverter attached)	62k Ω (20°C)
5	Outside air temp. sensor (TO sensor)	(Inverter attached)	10k Ω (25°C)
6	Heat exchanger temp. sensor (TE sensor)	(Inverter attached)	10k Ω (25°C)
7	Terminal block (6P)	JX0-6B	20A, AC250V
8	Compressor	DA150A1T-21F	3-phases 4-poles 1100W
9	Coil for PMV	CAM-MD12TCTH-5	DC12V
10	Coil for 4-way valve	STF-H01AZ1724A1	DC12V
11	High pressure switch	ACB-4UB83W	OFF : 4.15+0, -0.3MPa

7. REFRIGERANT CYCLE DIAGRAM

7-1. Refrigerant Cycle Diagram

HWS-455XWHM3-E / HWS-455H-E

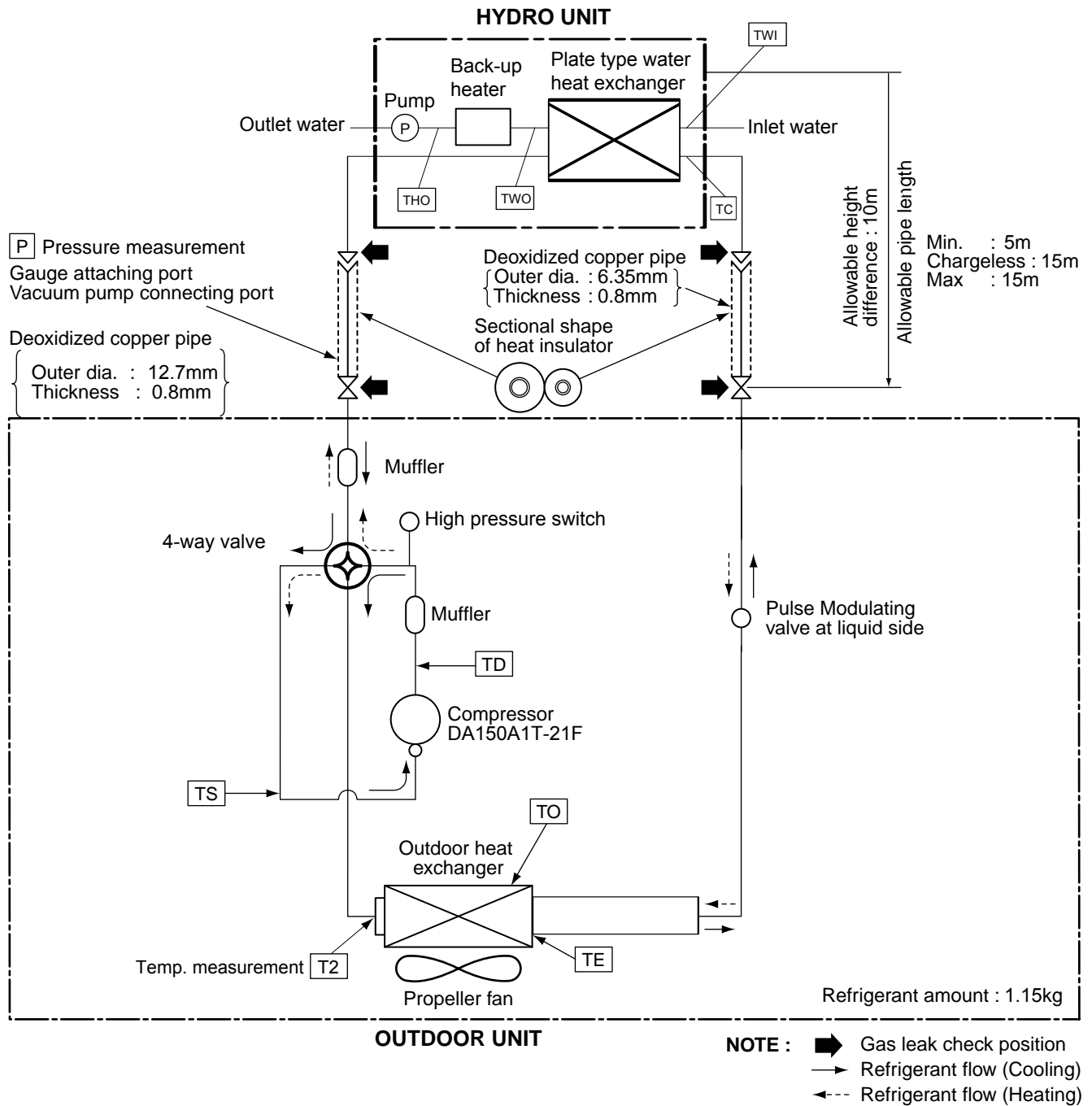

NOTE :

- The maximum pipe length of this air to water heat pump is 15 m. (chargeless)

7-2. Operation Data**<Cooling>**

Temperature condition(°C)		Standard pressure P (MPa)	Heat exchanger pipe temp.	Water flow rate (L / min)	Compressor revolution (rps)
Water In / Out	Outdoor		T2 (°C)		
12/7	35/-	0.8	43 to 45	13	68

<Heating>

Temperature condition(°C)		Standard pressure P (MPa)	Heat exchanger pipe temp.	Water flow rate (L / min)	Compressor revolution (rps)
Water In / Out	Outdoor		T2 (°C)		
30/35	7/6	2.2	2 to 4	13	52

NOTES :

1. Measure surface temperature of heat exchanger pipe around center of heat exchanger path U bent.
(Thermistor thermometer)
2. Connecting piping condition : 7.5 m

8. CONTROL BLOCK DIAGRAM

Outdoor Unit (Inverter Assembly)

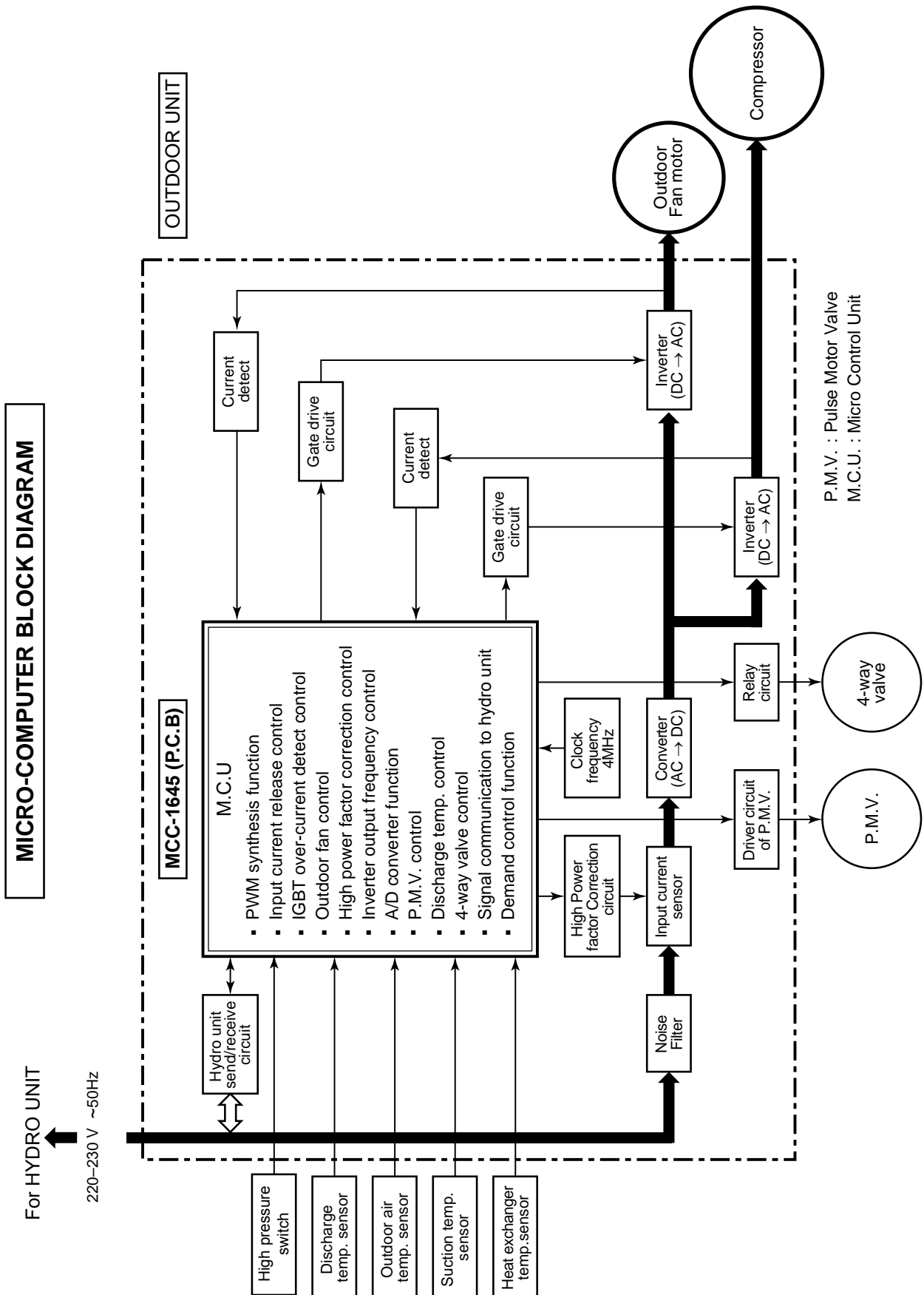

9. OPERATION DESCRIPTION

9-1. Outline of Air To Water Heat Pump Control

This air to water heat pump is a capacity-variable type air to water heat pump, which uses DC motor for the outdoor fan motor. And the capacity-proportional control compressor which can change the motor speed in the range from 9 to 80 rps is mounted. The compressor and the inverter to control fan motor are mounted to the outdoor unit.

The entire air to water heat pump is mainly controlled by the hydro unit controller.

The hydro unit controller drives the hydro water pump based upon command sent from the remote controller, and transfers the operation command to the outdoor unit controller.

The outdoor unit controller receives operation command from the hydro unit side, and controls the outdoor fan and the pulse Modulating valve. (P.M.V) Besides, detecting revolution position of the compressor motor, the outdoor unit controller controls speed of the compressor motor by controlling output voltage of the inverter and switching timing of the supply power (current transfer timing) so that motors drive according to the operation command.

And then, the outdoor unit controller transfers reversely the operating status information of the outdoor unit to control the hydro unit controller.

As the compressor adopts four-pole brushless DC motor, the frequency of the supply power from inverter to compressor is two-times cycles of the actual number of revolution.

1. Role of hydro unit controller

The hydro unit controller judges the operation commands from the remote controller and assumes the following functions.

- Judgment of water temperature of the hydro heat exchanger by using the hydro temp. sensor.(TWI, TWO, THO sensor)
- Judgment of the hydro heat exchanger temperature by using heat exchanger sensor (TC sensor) (Prevent-freezing control, etc.)
- Hydro water pump operation control
- Transferring of operation command signal (Serial signal) to the outdoor unit
- Reception of information of operation status (Serial signal including outside temp. data) to the outdoor unit and judgment/display of error

2. Role of outdoor unit controller

Receiving the operation command signal (Serial signal) from the hydro unit controller, the outdoor unit performs its role.

- Compressor operation control
- Operation control of outdoor fan motor
- P.M.V. control
- 4-way valve control

} Operations followed to judgment of serial signal from hydro side.

- Detection of inverter input current and current release operation
- Over-current detection and prevention operation to IGBT module (Compressor stop function)
- Compressor and outdoor fan stop function when serial signal is off (when the serial signal does not reach the board assembly of outdoor control by trouble of the signal system)
- Transferring of operation information (Serial signal) from outdoor unit controller to hydro unit controller
- Detection of outdoor temperature and operation revolution control
- Defrost control in heating operation (Temp. measurement by outdoor heat exchanger and control for 4-way valve and outdoor fan)

3. Contents of operation command signal (Serial signal) from hydro unit controller to outdoor unit controller

The following three types of signals are sent from the hydro unit controller.

- Operation mode set on the remote controller
- Compressor revolution command signal defined by hydro temperature and set temperature
- Temperature of hydro heat exchanger
- For these signals ([Operation mode] and [Compressor revolution] hydro heat exchanger temperature), the outdoor unit controller monitors the input current to the inverter, and performs the followed operation within the range that current does not exceed the allowable value.

4. Contents of operation command signal (Serial signal) from outdoor unit controller to hydro unit controller

The following signals are sent from the outdoor unit controller.

- The current operation mode
- The current compressor revolution
- Outdoor temperature
- Existence of protective circuit operation
For transferring of these signals, the hydro unit controller monitors the contents of signals, and judges existence of trouble occurrence. Contents of judgment are described below.
 - Whether distinction of the current operation status meets to the operation command signal
 - Whether protective circuit operates
When no signal is received from the outdoor unit controller, it is assumed as a trouble.

9-2. Operation Description

1. Basic operation	23
1. Operation control	23
2.Outdoor fan motor control	24
3.Current release control	25
4.Defrost control (Only in heating operation)	26
5.Discharge temperature control	27
6.High pressure control.....	27
7.Pulse Modulating valve (P.M.V.) control	28

Item	Operation flow and applicable data, etc.	Description
<p>1. Basic operation</p>	<p>1. Operation control</p> <p>Receiving the user's operation condition setup, the operation statuses of hydro/outdoor units are controlled.</p> <ol style="list-style-type: none"> 1) The operation conditions are selected by the remote controller as shown in the below. 2) A signal is sent by ON button of the remote controller. 3) The signal is received by the hydro unit and processed by the hydro controllers as shown in the below. The power relay is tuned ON and power supply to the outdoor unit. 4) The hydro controller controls the hydro circulation pump. 5) The hydro controller sends the operation command to the outdoor controller, and sends/receives the control status with a serial signal. 6) The outdoor controller controls the operation as shown in the below, and also controls the compressor, outdoor fan motor, 4-way valve and pulse Modulating valve are controlled <p style="text-align: center;">Remote controller</p> <p>Remote controller</p> <ul style="list-style-type: none"> Selection of operation conditions Control contents of remote controller <ul style="list-style-type: none"> • Temperature setup • Auto Temp • Anti Bacteria • Frost Protection • Hot water boost Heating : Run / Stop Hot water supply : Run / Stop Cooling : Run / Stop Serial signals <p>Hydro unit</p> <ul style="list-style-type: none"> Serial signals Unit control <ul style="list-style-type: none"> • Hydro unit control <ul style="list-style-type: none"> • Command signal generating function for hydro unit operation • Calculation function (temperature calculation) • Hydro heat exchanger release control Operation command Serial signal transmission • Circulation pump • Back up heater • 2WV_W • 3WV_W • Mixing Valve <p>Outdoor unit</p> <ul style="list-style-type: none"> Serial signals Transmission <ul style="list-style-type: none"> • Outdoor unit control <ul style="list-style-type: none"> • Inverter output frequency control • Waveform composite function • Calculation function (temperature calculation) • AD conversion function • Quick heating function • Compressor reactivation delay function • Current release function • GTr overload protective function • Defrost operation function • Outdoor temperature estimation Inverter <ul style="list-style-type: none"> • Compressor • Outdoor fan motor • Pulse modulating valve • Four-way valve 	

Item	Operation flow and applicable data, etc.	Description																																																																																																																																												
<p>2. Outdoor fan motor control</p>	<p>The blowing air volume at the outdoor unit side is controlled. Receiving the operation command from the controller of hydro unit, the controller of outdoor unit controls fan speed.</p> <p>* For the fan motor, a DC motor with non-stage variable speed system is used. However, it is limited to 8 stages for reasons of controlling.</p>	<ol style="list-style-type: none"> 1) The operation command sent from the remote controller is processed by the hydro unit controller and transferred to the controller of the outdoor unit. 2) When strong wind blows at outdoor side, the operation of air to water heat pump continues with the fan motor stopped. 3) Whether the fan is locked or not is detected, and the operation of air to water heat pump stops and an alarm is displayed if the fan is locked. 4) According to each operation mode, by the conditions of outdoor temperature (To) and compressor revolution, the speed of the outdoor fan shown in the table is selected. 																																																																																																																																												
<table border="1" style="width: 100%; border-collapse: collapse;"> <thead> <tr> <th colspan="7" style="text-align: center;">In Cooling operation</th> <th colspan="5" style="text-align: center;">In Heating operation</th> </tr> <tr> <th colspan="2" rowspan="2">Compressor speed (Hz)</th> <th colspan="2">Hz < 13.8</th> <th colspan="2">13.8 ≤ Hz ≤ 32.4</th> <th colspan="2">32.4 < Hz</th> <th colspan="2" rowspan="2">Compressor speed (Hz)</th> <th colspan="2">Hz < 16.8</th> <th colspan="2">16.8 ≤ Hz ≤ 47.4</th> <th colspan="2">47.4 < Hz</th> </tr> <tr> <th>MIN</th> <th>MAX</th> <th>MIN</th> <th>MAX</th> <th>MIN</th> <th>MAX</th> <th>MIN</th> <th>MAX</th> <th>MIN</th> <th>MAX</th> <th>MIN</th> <th>MAX</th> </tr> </thead> <tbody> <tr> <td rowspan="7" style="text-align: center; vertical-align: middle;">To</td> <td>To ≥ 38°C</td> <td>W6</td> <td>WB</td> <td>W8</td> <td>WE</td> <td>WA</td> <td>WE</td> <td rowspan="7" style="text-align: center; vertical-align: middle;">TO</td> <td>To ≥ 30°C</td> <td>W4</td> <td>W4</td> <td>W6</td> <td>W6</td> </tr> <tr> <td>To ≥ 29°C</td> <td>W5</td> <td>WA</td> <td>W7</td> <td>WE</td> <td>W9</td> <td>WE</td> <td>To ≥ 25°C</td> <td>W5</td> <td>W5</td> <td>W7</td> <td>W7</td> </tr> <tr> <td>To ≥ 15°C</td> <td>W3</td> <td>W7</td> <td>W5</td> <td>W9</td> <td>W7</td> <td>WB</td> <td>To ≥ 20°C</td> <td>W6</td> <td>W7</td> <td>W8</td> <td>W8</td> </tr> <tr> <td>To ≥ 5°C</td> <td>W2</td> <td>W5</td> <td>W4</td> <td>W7</td> <td>W6</td> <td>W9</td> <td>To ≥ 10°C</td> <td>W7</td> <td>W8</td> <td>W9</td> <td>W9</td> </tr> <tr> <td>To ≥ 0°C</td> <td>W1</td> <td>W3</td> <td>W3</td> <td>W5</td> <td>W4</td> <td>W7</td> <td>To ≥ 5°C</td> <td>W9</td> <td>WB</td> <td>WE</td> <td>WE</td> </tr> <tr> <td>To ≥ -4°C</td> <td>W1</td> <td>W2</td> <td>W2</td> <td>W4</td> <td>W3</td> <td>W5</td> <td>To ≥ -3°C</td> <td>WE</td> <td>WE</td> <td>WE</td> <td>WE</td> </tr> <tr> <td>To < -4°C</td> <td>OFF</td> <td>OFF</td> <td>OFF</td> <td>W3</td> <td>W1</td> <td>W4</td> <td>To ≥ -10°C</td> <td>WE</td> <td>WE</td> <td>WE</td> <td>WE</td> </tr> <tr> <td colspan="2">When To is abnormal</td> <td>OFF</td> <td>WB</td> <td>OFF</td> <td>WE</td> <td>W1</td> <td>WE</td> <td colspan="2">When To is abnormal</td> <td>WE</td> <td>WE</td> <td>WE</td> <td>WE</td> </tr> </tbody> </table>			In Cooling operation							In Heating operation					Compressor speed (Hz)		Hz < 13.8		13.8 ≤ Hz ≤ 32.4		32.4 < Hz		Compressor speed (Hz)		Hz < 16.8		16.8 ≤ Hz ≤ 47.4		47.4 < Hz		MIN	MAX	MIN	MAX	MIN	MAX	MIN	MAX	MIN	MAX	MIN	MAX	To	To ≥ 38°C	W6	WB	W8	WE	WA	WE	TO	To ≥ 30°C	W4	W4	W6	W6	To ≥ 29°C	W5	WA	W7	WE	W9	WE	To ≥ 25°C	W5	W5	W7	W7	To ≥ 15°C	W3	W7	W5	W9	W7	WB	To ≥ 20°C	W6	W7	W8	W8	To ≥ 5°C	W2	W5	W4	W7	W6	W9	To ≥ 10°C	W7	W8	W9	W9	To ≥ 0°C	W1	W3	W3	W5	W4	W7	To ≥ 5°C	W9	WB	WE	WE	To ≥ -4°C	W1	W2	W2	W4	W3	W5	To ≥ -3°C	WE	WE	WE	WE	To < -4°C	OFF	OFF	OFF	W3	W1	W4	To ≥ -10°C	WE	WE	WE	WE	When To is abnormal		OFF	WB	OFF	WE	W1	WE	When To is abnormal		WE	WE	WE	WE
In Cooling operation							In Heating operation																																																																																																																																							
Compressor speed (Hz)		Hz < 13.8		13.8 ≤ Hz ≤ 32.4		32.4 < Hz		Compressor speed (Hz)		Hz < 16.8		16.8 ≤ Hz ≤ 47.4		47.4 < Hz																																																																																																																																
		MIN	MAX	MIN	MAX	MIN	MAX			MIN	MAX	MIN	MAX	MIN	MAX																																																																																																																															
To	To ≥ 38°C	W6	WB	W8	WE	WA	WE	TO	To ≥ 30°C	W4	W4	W6	W6																																																																																																																																	
	To ≥ 29°C	W5	WA	W7	WE	W9	WE		To ≥ 25°C	W5	W5	W7	W7																																																																																																																																	
	To ≥ 15°C	W3	W7	W5	W9	W7	WB		To ≥ 20°C	W6	W7	W8	W8																																																																																																																																	
	To ≥ 5°C	W2	W5	W4	W7	W6	W9		To ≥ 10°C	W7	W8	W9	W9																																																																																																																																	
	To ≥ 0°C	W1	W3	W3	W5	W4	W7		To ≥ 5°C	W9	WB	WE	WE																																																																																																																																	
	To ≥ -4°C	W1	W2	W2	W4	W3	W5		To ≥ -3°C	WE	WE	WE	WE																																																																																																																																	
	To < -4°C	OFF	OFF	OFF	W3	W1	W4		To ≥ -10°C	WE	WE	WE	WE																																																																																																																																	
When To is abnormal		OFF	WB	OFF	WE	W1	WE	When To is abnormal		WE	WE	WE	WE																																																																																																																																	
<p>Outdoor fan speed (rpm)</p> <table border="1" style="width: 50%; border-collapse: collapse;"> <thead> <tr> <th>Tap</th> <th>RAS-10G2AVP-E</th> <th>RAS-13G2AVP-E</th> <th>RAS-16G2AVP-E</th> </tr> </thead> <tbody> <tr><td>W0</td><td>0</td><td>0</td><td>0</td></tr> <tr><td>W1</td><td>250</td><td>250</td><td>250</td></tr> <tr><td>W2</td><td>310</td><td>300</td><td>310</td></tr> <tr><td>W3</td><td>380</td><td>350</td><td>380</td></tr> <tr><td>W4</td><td>430</td><td>450</td><td>430</td></tr> <tr><td>W5</td><td>470</td><td>500</td><td>470</td></tr> <tr><td>W6</td><td>550</td><td>560</td><td>550</td></tr> <tr><td>W7</td><td>610</td><td>600</td><td>610</td></tr> <tr><td>W8</td><td>610</td><td>650</td><td>640</td></tr> </tbody> </table> <table border="1" style="width: 50%; border-collapse: collapse;"> <thead> <tr> <th>Tap</th> <th>RAS-10G2AVP-E</th> <th>RAS-13G2AVP-E</th> <th>RAS-16G2AVP-E</th> </tr> </thead> <tbody> <tr><td>W9</td><td>610</td><td>700</td><td>700</td></tr> <tr><td>WA</td><td>610</td><td>700</td><td>750</td></tr> <tr><td>WB</td><td>610</td><td>700</td><td>800</td></tr> <tr><td>WC</td><td>610</td><td>700</td><td>800</td></tr> <tr><td>WD</td><td>610</td><td>700</td><td>800</td></tr> <tr><td>WE</td><td>610</td><td>700</td><td>800</td></tr> <tr><td>WF</td><td>700</td><td>850</td><td>800</td></tr> </tbody> </table>			Tap	RAS-10G2AVP-E	RAS-13G2AVP-E	RAS-16G2AVP-E	W0	0	0	0	W1	250	250	250	W2	310	300	310	W3	380	350	380	W4	430	450	430	W5	470	500	470	W6	550	560	550	W7	610	600	610	W8	610	650	640	Tap	RAS-10G2AVP-E	RAS-13G2AVP-E	RAS-16G2AVP-E	W9	610	700	700	WA	610	700	750	WB	610	700	800	WC	610	700	800	WD	610	700	800	WE	610	700	800	WF	700	850	800																																																																				
Tap	RAS-10G2AVP-E	RAS-13G2AVP-E	RAS-16G2AVP-E																																																																																																																																											
W0	0	0	0																																																																																																																																											
W1	250	250	250																																																																																																																																											
W2	310	300	310																																																																																																																																											
W3	380	350	380																																																																																																																																											
W4	430	450	430																																																																																																																																											
W5	470	500	470																																																																																																																																											
W6	550	560	550																																																																																																																																											
W7	610	600	610																																																																																																																																											
W8	610	650	640																																																																																																																																											
Tap	RAS-10G2AVP-E	RAS-13G2AVP-E	RAS-16G2AVP-E																																																																																																																																											
W9	610	700	700																																																																																																																																											
WA	610	700	750																																																																																																																																											
WB	610	700	800																																																																																																																																											
WC	610	700	800																																																																																																																																											
WD	610	700	800																																																																																																																																											
WE	610	700	800																																																																																																																																											
WF	700	850	800																																																																																																																																											

Item	Operation flow and applicable data, etc.	Description																		
<p>3. Current release control</p>	<p>This function prevents troubles on the electronic parts of the compressor driving inverter.</p> <p>This function also controls drive circuit of the compressor speed so that electric power of the compressor drive circuit does not exceed the specified value.</p> <pre> graph TD A[Outdoor unit inverter main circuit control current] --> B{Operating current ≤ Setup value} C[Outdoor temp. To] --> D[Setup of current release point] D --> B B -- High --> E[Reduce compressor speed] E --> F{Current decrease} B -- Low --> G[Capacity control continues.] </pre>	<ol style="list-style-type: none"> 1) The input current of the outdoor unit is detected in the inverter section of the outdoor unit. 2) According to the detected outdoor temperature, the specific value of the current is selected. 3) Whether the current value exceeds the specific value or not is judged. 4) If the current value exceeds the specified value, this function reduces the compressor speed and controls speed up to the closest one commanded from the hydro unit within the range which does not exceed the specified value. 																		
	<table border="1" data-bbox="188 801 1241 1093"> <thead> <tr> <th data-bbox="188 801 475 891">Outdoor temp.</th> <th data-bbox="475 801 858 891">Cooling current release value</th> <th data-bbox="858 801 1241 891">Heating current release value</th> </tr> </thead> <tbody> <tr> <td data-bbox="188 891 475 925">45°C</td> <td data-bbox="475 891 858 925">6.5A</td> <td data-bbox="858 891 1241 925"></td> </tr> <tr> <td data-bbox="188 925 475 958">40°C</td> <td data-bbox="475 925 858 958">6.8A</td> <td data-bbox="858 925 1241 958"></td> </tr> <tr> <td data-bbox="188 958 475 992">16°C</td> <td data-bbox="475 958 858 992">8.5A</td> <td data-bbox="858 958 1241 992">9.5A</td> </tr> <tr> <td data-bbox="188 992 475 1025">11°C</td> <td data-bbox="475 992 858 1025"></td> <td data-bbox="858 992 1241 1025">10.2A</td> </tr> <tr> <td data-bbox="188 1025 475 1059"></td> <td data-bbox="475 1025 858 1059"></td> <td data-bbox="858 1025 1241 1059">10.8A</td> </tr> </tbody> </table>	Outdoor temp.	Cooling current release value	Heating current release value	45°C	6.5A		40°C	6.8A		16°C	8.5A	9.5A	11°C		10.2A			10.8A	
Outdoor temp.	Cooling current release value	Heating current release value																		
45°C	6.5A																			
40°C	6.8A																			
16°C	8.5A	9.5A																		
11°C		10.2A																		
		10.8A																		

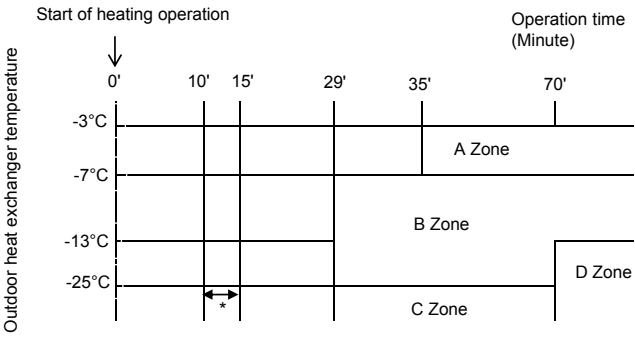
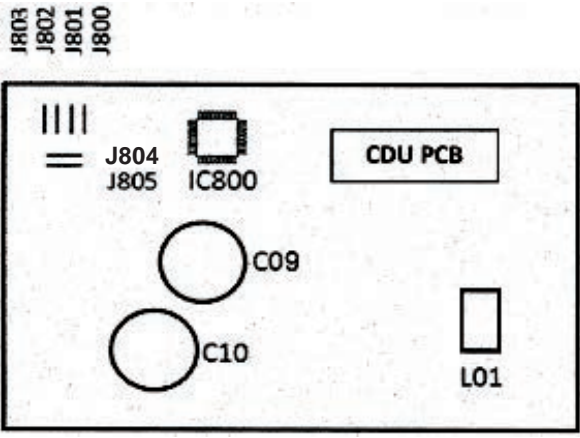
Item	Operation flow and applicable data, etc.	Description										
<p>4. Defrost control (Only in heating operation)</p>	<p>(This function removes frost adhered to the outdoor heat exchanger.)</p> <p>The temperature sensor of the outdoor heat exchanger (Te sensor) judges the frosting status of the outdoor heat exchanger and the defrost operation is performed with 4-way valve reverse defrost system.</p>  <p>* The minimum value of Te sensor 10 to 15 minutes after start of operation is stored in memory as Te0.</p> <p>Table 1</p> <table border="1" data-bbox="172 1048 938 1317"> <thead> <tr> <th>Zone</th> <th>Condition</th> </tr> </thead> <tbody> <tr> <td>A zone</td> <td>When $(TE0 - TE) - (TO0 - TO) \geq 3^{\circ}C$ and $SH-SHO \leq 2$ in A zone, defrost operation starts.</td> </tr> <tr> <td>B zone</td> <td>When $(TE0 - TE) - (TO0 - TO) \geq 2^{\circ}C$ and $SH-SHO \leq 2$ in B zone, defrost operation starts.</td> </tr> <tr> <td>C zone</td> <td>When $TE \leq -25^{\circ}C$ and $SH-SHO \leq 2$ in C zone, defrost operation starts.</td> </tr> <tr> <td>D zone</td> <td>More than 70 minutes accumulated heating operation time condition $TE < -13^{\circ}C$</td> </tr> </tbody> </table> <ul style="list-style-type: none"> • Strong defrost Upgrade defrost ability when normal defrost ability is not enough by increase defrosting finished operation. • Do cut the jumper J803 on CDU PCB 	Zone	Condition	A zone	When $(TE0 - TE) - (TO0 - TO) \geq 3^{\circ}C$ and $SH-SHO \leq 2$ in A zone, defrost operation starts.	B zone	When $(TE0 - TE) - (TO0 - TO) \geq 2^{\circ}C$ and $SH-SHO \leq 2$ in B zone, defrost operation starts.	C zone	When $TE \leq -25^{\circ}C$ and $SH-SHO \leq 2$ in C zone, defrost operation starts.	D zone	More than 70 minutes accumulated heating operation time condition $TE < -13^{\circ}C$	<p>The necessity of defrost operation is detected by the outdoor heat exchanger temperature. The conditions to detect the necessity of defrost operation differ in A, B, or C zone each. (Table 1)</p> <p><Defrost operation></p> <ul style="list-style-type: none"> • Defrost operation in A to C zones <ol style="list-style-type: none"> 1) Stop operation of the compressor for 20 seconds. 2) Invert (ON) 4-way valve 10 seconds after stop of the compressor. 3) The outdoor fan stops at the same time when the compressor stops. <p><Finish of defrost operation></p> <ul style="list-style-type: none"> • Returning conditions from defrost operation to heating operation <ol style="list-style-type: none"> 1) Temperature of outdoor heat exchanger rises to $+8^{\circ}C$ or higher. 2) Temperature of outdoor heat exchanger is kept at $+5^{\circ}C$ or higher for 80 seconds. 3) Defrost operation continues for 15 minutes. <p><Returning from defrost operation></p> <ol style="list-style-type: none"> 1) Stop operation of the compressor for approx. 50 seconds. 2) Invert (OFF) 4-way valve approx. 40 seconds after stop of the compressor. 3) The outdoor fan starts rotating at the same time when the compressor starts. <p><Finish of defrost operation for strong defrost></p> <ul style="list-style-type: none"> • Returning conditions from defrost operation to heating operation <ol style="list-style-type: none"> 1) Temperature of outdoor heat exchanger rises to $+13^{\circ}C$ or higher. 2) Temperature of outdoor heat exchanger is kept at $+10^{\circ}C$ or higher for 80 seconds. 3) Defrost operation continues for 20 minutes.
Zone	Condition											
A zone	When $(TE0 - TE) - (TO0 - TO) \geq 3^{\circ}C$ and $SH-SHO \leq 2$ in A zone, defrost operation starts.											
B zone	When $(TE0 - TE) - (TO0 - TO) \geq 2^{\circ}C$ and $SH-SHO \leq 2$ in B zone, defrost operation starts.											
C zone	When $TE \leq -25^{\circ}C$ and $SH-SHO \leq 2$ in C zone, defrost operation starts.											
D zone	More than 70 minutes accumulated heating operation time condition $TE < -13^{\circ}C$											

Item	Operation flow and applicable data, etc.		Description
5. Discharge temperature control			<p>1. Purpose This function detects error on the refrigerating cycle or error on the compressor, and performs protective control.</p> <p>2. Operation Control of the compressor speed The speed control is performed as described in the left table based upon the discharge temperature.</p>
Td value	Control operation		
117°C	Judges as an error and stops the compressor.		
115°C	Reduce the compressor speed.		
103°C	Reduce slowly compressor speed.		
100°C	Keeps the compressor speed.		
93°C	If the operation is performed with lower speed than one commanded by the serial signal, speed is slowly raised up to the commanded speed. Operates with speed commanded by the serial signal.		
6. High pressure control			<p>1. Purpose This function detects error on the refrigerating cycle or error on the compressor, and performs protective control.</p> <p>2. Operation Control of the compressor speed The speed control is performed as described in the left table based upon the heat exchanger temperature (TE, TC).</p>
Cooling (TE)	Heating (TC)	Control operation	
63°C	64°C	Judges as an error and stops the compressor.	
63°C	62°C	Reduce the compressor speed.	
61°C	60°C	Reduce slowly compressor speed.	
59°C	58°C	Keeps the compressor speed.	
55°C	54°C	If the operation is performed with lower speed than one commanded by the serial signal, speed is slowly raised up to the commanded speed. Operates with speed commanded by the serial signal.	

Item	Operation flow and applicable data, etc.	Description
<p>7. Pulse Modulating valve (P.M.V.) control</p>	<p>This function controls throttle amount of the refrigerant in the refrigerating cycle. According to operating status of the air to water heat pump system, this function also controls the open degree of valve with an expansion valve with pulse Modulation.</p> <pre> graph TD Start[Starting up] --> Init[Initialize] Init --> MoveInit[Move to initial position] MoveInit --> CompOn[Compressor ON] CompOn --> SH[SH control] CompOn --> Td[Td, high pressure release control] SH --> PMV[PMV open degree control] Td --> PMV PMV --> TurnOff[Turn OFF by remote controller] PMV --> CompStop[Compressor Stop by "Room Temperature Control"] PMV --> Defrost[Defrosting operation] TurnOff --> MoveStop[Move to "Stop Position" (Setup from factory)] CompStop --> MoveStop Defrost --> MoveDefrost[Move to "Defrost Position" (Setup from factory)] </pre> <p>* SH (Super Heat amount) = Ts (Temperature of suction pipe of the compressor) – Tc or Te (Heat exchanger temperature at evaporation side)</p> <p>* PMV: Pulse Modulating Valve</p>	<ol style="list-style-type: none"> 1) When starting the operation, move the valve once until it fits to the stopper. (Initialize) * In this time, "Click" sound may be heard. 2) Adjust the open degree of valve by super heat amount. (SH control) 3) If the discharge temperature was excessively up, adjust the open degree of valve so that it is in the range of set temperature. (Discharge temp. control) 4) When defrost operation is performed, the open degree of valve is adjusted according to each setup conditions during preparation for defrost and during defrost operation (4-way valve is inversed.). 5) When operation is OFF by the remote controller or when compressor is OFF by room temperature control, the open degree of valve is adjusted to the stop position.

10. INSTALLATION PROCEDURE

10-1. Installation Diagram of Hydro and Outdoor Units

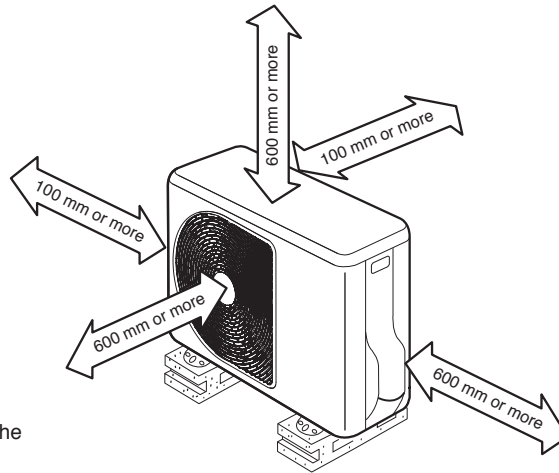

Remark :

- Some pictures might be different from the actual parts.

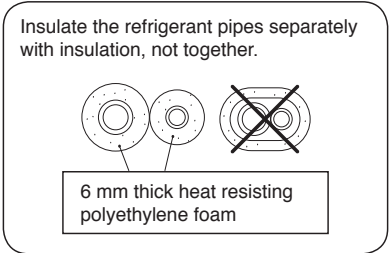

10-2. Installation

10-2-1. Optional installation parts

Part Code	Parts name	Q'ty
A	Refrigerant piping Liquid side : $\text{Ø}6.35$ mm Gas side : $\text{Ø}12.70$ mm	One each
B	Pipe insulating material (polyethylene foam, 6 mm thick)	1
C	Putty, PVC tapes	One each

Fixing bolt arrangement of outdoor unit

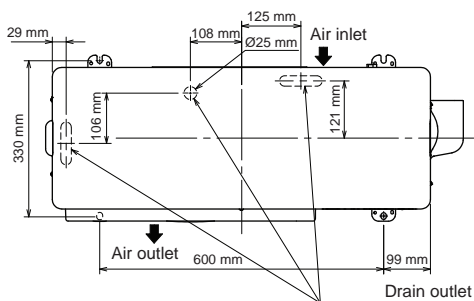

* Drain nipple and cap water proof are packed in outdoor unit.

Fig. 10-2-1

- Secure the outdoor unit with fixing bolts and nuts if the unit is likely to be exposed to a strong wind.
- Use $\text{Ø}8$ mm or $\text{Ø}10$ mm anchor bolts and nuts.
- If it is necessary to drain the defrost water, attach drain nipple and cap water proof to the bottom plate of the outdoor unit before installing it.

10-2-2. Accessory and installation parts

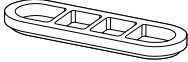
Part No.	Part name (Q'ty)
	 <p data-bbox="236 472 405 501">Drain nipple* x 1</p>
	 <p data-bbox="236 678 443 707">Cap water proof* x 2</p>

The part marked with asterisk (*) is packaged with the outdoor unit.

Others







Name
Installation manual

10-2-3. Installation/Serviceing Tools**Changes in the product and components**

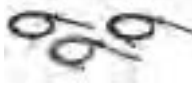
In the case of an air to water heat pump using R410A, in order to prevent any other refrigerant from being charged accidentally, the service port diameter of the outdoor unit control valve (3 way valve) has been changed.(1/2 UNF 20 threads per inch)

- In order to increase the pressure resisting strength of the refrigerant piping flare processing diameter and size of opposite side of flare nuts has been changed. (for copper pipes with nominal dimensions 1/2 and 5/8)

New tools for R410A

New tools for R410A	Applicable to R22 model		Changes
Gauge manifold	×		As pressure is high, it is impossible to measure by means of conventional gauge. In order to prevent any other refrigerant from being charged, each port diameter has been changed.
Charge hose	×		In order to increase pressure resisting strength, hose materials and port size have been changed (to 1/2 UNF 20 threads per inch). When purchasing a charge hose, be sure to confirm the port size.
Electronic balance for refrigerant charging	○		As pressure is high and gasification speed is fast, it is difficult to read the indicated value by means of charging cylinder, as air bubbles occur.
Torque wrench (nominal diam. 1/2, 5/8)	×		The size of opposite sides of flare nuts have been increased. Incidentally, a common wrench is used for nominal diameters 1/4 and 3/8.
Flare tool (clutch type)	○		By increasing the clamp bar's receiving hole, strength of spring in the tool has been improved.
Gauge for projection adjustment	—	—	Used when flare is made by using conventional flare tool.
Vacuum pump adapter	○		Connected to conventional vacuum pump. It is necessary to use an adapter to prevent vacuum pump oil from flowing back to the charge hose. The charge hose connecting part has two ports-one for conventional refrigerant (7/16 UNF 20 threads per inch) and one for R410A. If the vacuum pump oil (mineral) mixes with R410A a sludge may occur and damage the equipment.
Gas leakage detector	×		Exclusive for HFC refrigerant.

- Incidentally, the “refrigerant cylinder” comes with the refrigerant designation (R410A) and protector coating in the U. S’s ARI specified rose color (ARI color code: PMS 507).
- Also, the “charge port and packing for refrigerant cylinder” require 1/2 UNF 20 threads per inch corresponding to the charge hose’s port size.

10-3. Outdoor Unit

10-3-1. Installation Place

- A place which provides enough space around the outdoor unit as shown in the diagram.
- A place which can bear the weight of the outdoor unit and does not allow an increase in noise level and vibration.
- A place where the operation noise and discharged air do not disturb neighbors.
- A place which is not exposed to a strong wind.
- A place free of combustible gases.
- A place which does not block a passageway.
- When the outdoor unit is to be installed in an elevated position, be sure to secure its feet.
- An allowable length & height, please refer from 2. SPECIFICATIONS.
- An allowable height level is up to 10 m.
- A place where the drain water does not cause any problems.

10-3-2. Precautions about Installation in Regions with Snowfall and Cold Temperatures

- Do not use the supplied drain nipple for draining water.
- Drain the water from all the drain holes directly.
- To protect the outdoor unit from snow accumulation, install a holding frame, and attach a snow protection hood and plate.
- Do not use a double-stacked design.

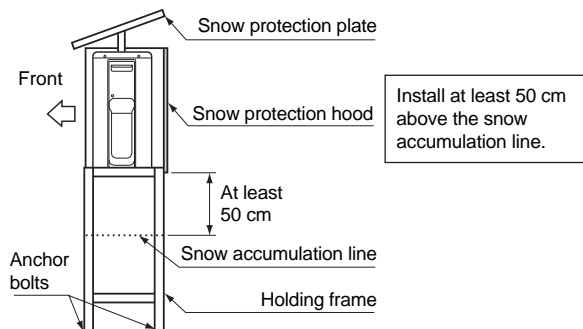

Fig. 10-3-1

CAUTION

1. Install the outdoor unit without anything blocking the discharging air.
2. When the outdoor unit is installed in a place always exposed to strong winds like on the coast or on a high story of a building, secure the normal fan operation using a duct or a wind shield.
3. Especially in windy areas, install the unit to prevent the admission of wind.
4. Installation in the following places may result in trouble.

Do not install the unit in such places.

- A place full of machine oil.
- A saline-place such as the coast.
- A place full of sulfide gas.
- A place where high-frequency waves are likely to be generated, such as from audio equipment, welders, and medical equipment.

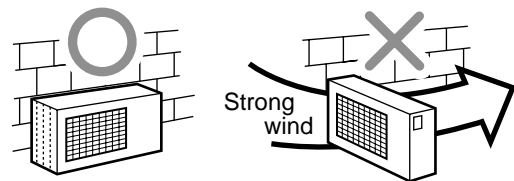

Fig. 10-3-2

10-3-3. Draining the Water

- Holes are provided on the base plate of the outdoor unit to ensure that the defrost water produced during heating operations is drained off efficiently.

If a centralized drain is required when installing the unit on a balcony or wall, follow the steps below to drain off the water.

- Proceed with water-proofing by installing the water-proof rubber caps in the 2 elongated holes on the base plate of the outdoor unit. [How to install the water-proof rubber caps]
 - Place four fingers into each cap, and insert the caps into the water drain holes by pushing them into place from the underside of the base plate.
 - Press down on the outer circumferences of the caps to ensure that they have been inserted tightly.
(Water leaks may result if the caps have not been inserted properly, if their outer circumferences lift up or the caps catch on or wedge against something.)

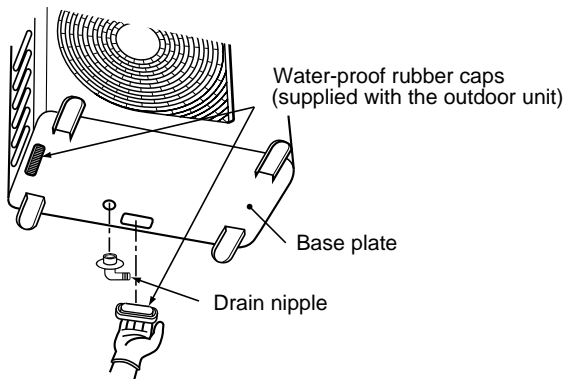
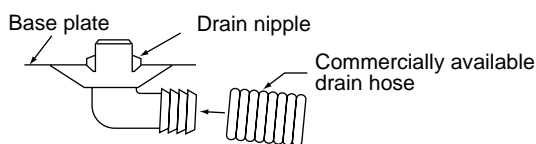

Fig. 10-3-3

- Install the drain nipple and a commercially available drain hose (with 16 mm inside diameter), and drain off the water.
(For the position where the drain nipple is installed, refer to the installation diagram of the hydro and outdoor units.)
 - Check that the outdoor unit is horizontal, and route the drain hose at a downward sloped angle while ensuring that it is connected tautly.



Do not use ordinary garden hose, but one can flatten and prevent water from draining.

Fig. 10-3-4

10-3-4. Refrigerant Piping Connection

Flaring

- Cut the pipe with a pipe cutter.

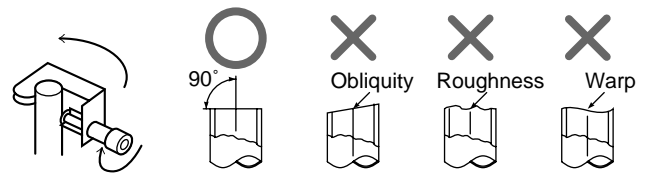

Fig. 10-3-5

- Insert a flare nut into the pipe, and flare the pipe.

- Projection margin in flaring : A (Unit : mm)**
Rigid (Clutch type)

Outer dia. of copper pipe	R410A tool used	Conventional tool used
Ø 6.35	0 to 0.5	1.0 to 1.5
Ø 9.52	0 to 0.5	1.0 to 1.5
Ø 12.7	0 to 0.5	1.0 to 1.5

- Imperial (Wing nut type)

Outer dia. of copper pipe	R410A
Ø 6.35	1.5 to 2.0
Ø 9.52	1.5 to 2.0
Ø 12.7	2.0 to 2.5

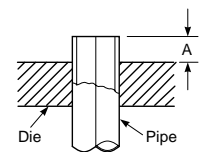

Fig. 10-3-6

- Flaring size : B (Unit : mm)**

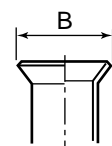

Fig. 10-3-7

Outer dia. of copper pipe	B ⁺⁰ / _{-0.4}	
	R410A	R22
Ø 6.35	9.1	9.0
Ø 9.52	13.2	13.0
Ø 12.7	16.6	16.2

- In case of flaring for R410A with the conventional flare tool, pull it out approx. 0.5 mm more than that of R22 to adjust to the specified flare size.

The copper pipe gauge is useful for adjusting projection margin size.

Tightening Connection

Align the centers of the connecting pipes and tighten the flare nut as much as possible with your fingers. Then tighten the nut with a wrench and torque wrench as shown in the figure.

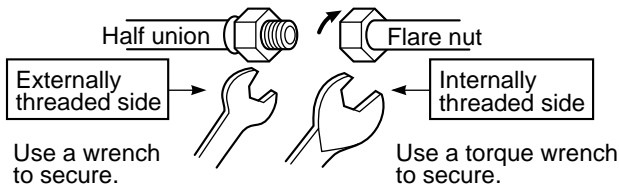

Fig. 10-3-8

CAUTION

- Do not apply excessive force. Otherwise, the nut may break.

(Unit : N·m)

Outer dia. of copper pipe	Tightening torque
Ø6.35 mm	14 to 18 (1.4 to 1.8 kgf·m)
Ø9.52 mm	33 to 42 (3.3 to 4.2 kgf·m)
Ø12.7 mm	50 to 62 (5.0 to 6.2 kgf·m)

- Tightening torque for connection of flare pipe The pressure of R410A is higher than R22. (Approx. 1.6 times.) Therefore securely tighten the flare pipes which connect the outdoor unit and the hydro unit with the specified tightening torque using a torque wrench.

If any flare pipe is incorrectly connected, it may cause not only a gas leakage but also trouble in the refrigeration cycle.

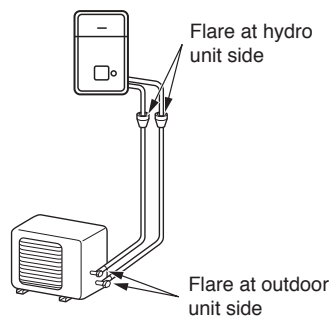
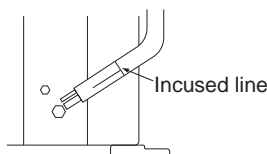

Fig. 10-3-9

Shaping pipes

- How to shape the pipes
Shape the pipes along the incused line on the outdoor unit.
- How to fit position of the pipes
Put the edges of the pipes to the place with a distance of 85 mm from the incused line.



10-3-5. Evacuating

After the piping has been connected to the hydro unit, perform the air purge.

AIR PURGE

Evacuate the air in the connecting pipes and in the hydro unit using a vacuum pump. Do not use the refrigerant in the outdoor unit. For details, see the vacuum pump manual.

Use a vacuum pump

Be sure to use a vacuum pump with counter-flow prevention function so that oil inside the pump does not flow back into the air to water heat pump pipes when the pump stops. (If oil inside the vacuum pump enters into the air to water heat pump circuit which uses R410A, trouble with the refrigeration system may develop.)

- Connect the charge hose from the manifold valve to the service port of the gas side packed valve.
- Connect the charge hose to the port of the vacuum pump.
- Open fully the low pressure side handle of the gauge manifold valve.
- Operate the vacuum pump to begin evacuating. Perform evacuating for about 15 minutes (assuming a pump capacity of 27 liters per minute). Confirm that the compound pressure gauge reading is -101 kPa (76 cmHg).
- Close the low pressure valve handle of gauge manifold.
- Open fully the valve stem of the packed valves (both sides of Gas and Liquid).
- Remove the charging hose from the service port.
- Securely tighten the caps on the packed valves.

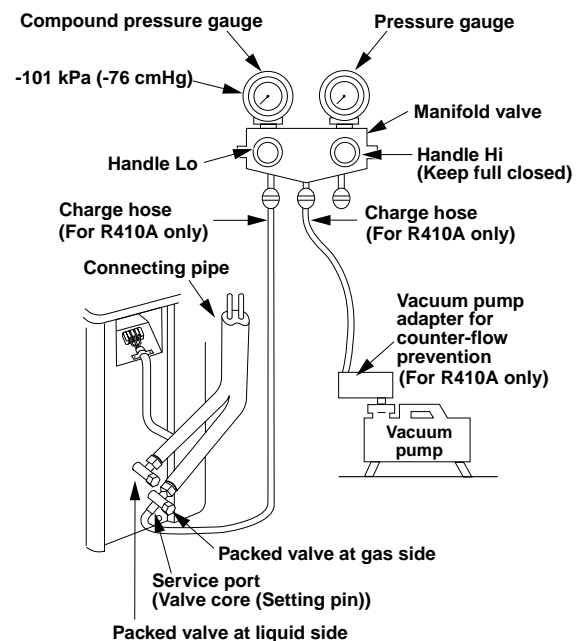

Fig. 10-3-10

CAUTION

• **KEEP IMPORTANT 5 POINTS FOR PIPING WORK**

- (1) Take away dust and moisture (Inside of the connecting pipes.)
- (2) Tight the connection (between pipes and unit)
- (3) Evacuate the air in the connecting pipes using a VACUUM PUMP.
- (4) Check gas leak (connected points)
- (5) Be sure to fully open the packed valves before operation.

<Packed valve handling precautions>

- Open the valve stem all the way out, but do not try to open it beyond the stopper.

Pipe size of Packed Valve	Size of Hexagon wrench
12.70 mm and smaller	A = 4 mm
15.88 mm	A = 5 mm

- Securely tighten the valve cap with torque in the following table

Cap	Cap Size (H)	Torque
Valve Rod Cap	H17 - H19	14~18 N.m (1.4 to 1.8 kgf·m)
	H22 - H30	33~42 N.m (3.3 to 4.2 kgf·m)
Service Port Cap	H14	8~12 N.m (0.8 to 1.2 kgf·m)
	H17	14~18 N.m (1.4 to 1.8 kgf·m)

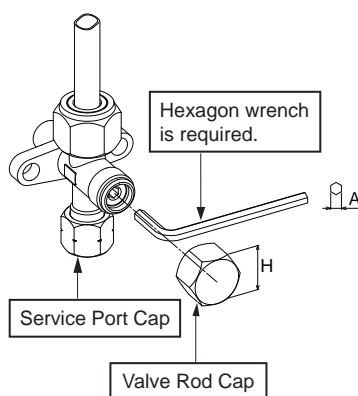

Fig. 10-3-11

10-4. Electrical works

Connect the power supply and connecting cable by follow the instruction as following.

Model	HWS-455H-E
Power source	50Hz, 220-230V Single phase
Maximum running current	11.1A
Circuit breaker rating	15A
Wire type : Power supply cable	More than H07RN-F or 60245 IEC66 (1.5 mm ² or more)
Connecting cable	More than H07RN-F or 60245 IEC66 (1.5 mm ² or more)

10-4-1. Wiring Connection

CAUTION

- Be sure to refer to the wiring system diagram labeled inside the main panel.
- Check local electrical cords and also any specific wiring instructions or limitations.

Outdoor unit

1. Remove the valve cover from the outdoor unit.
2. Connect the cable to the terminals as identified with their respective matched numbers on the terminal block of hydro and outdoor unit.
3. When connecting the cable to the outdoor unit terminals, make a loop as shown in the installation diagram of hydro and outdoor unit to prevent water coming in the outdoor unit.
4. Insulate the unused cords (conductors) from any water coming in the outdoor unit. Proceed them so that they do not touch any electrical or metal parts.

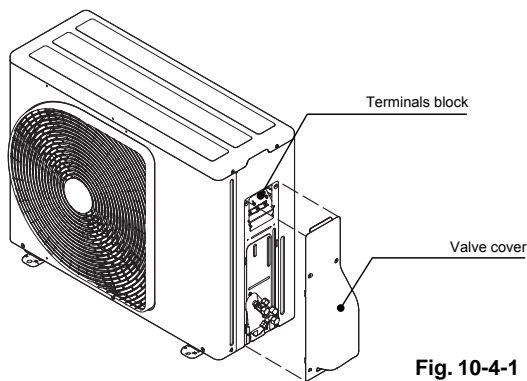

10-4-2. Power Supply and Connecting Cable Connection

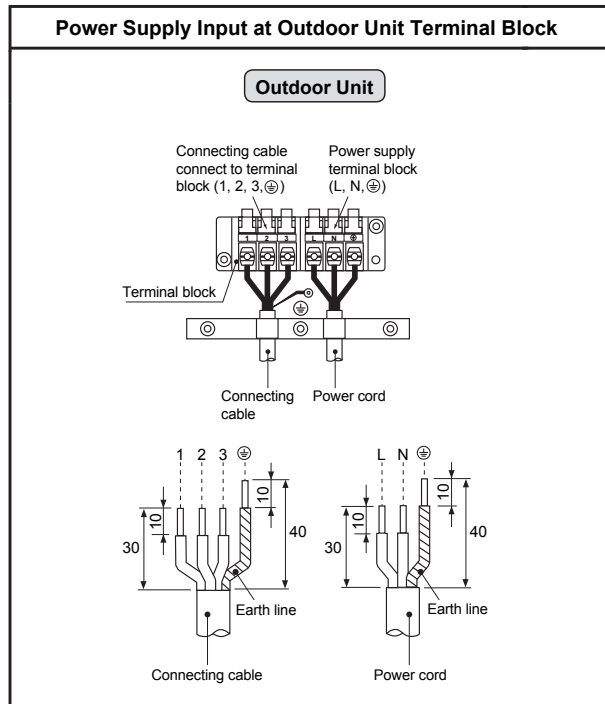

10-4-3. Power Supply input Wiring Diagram

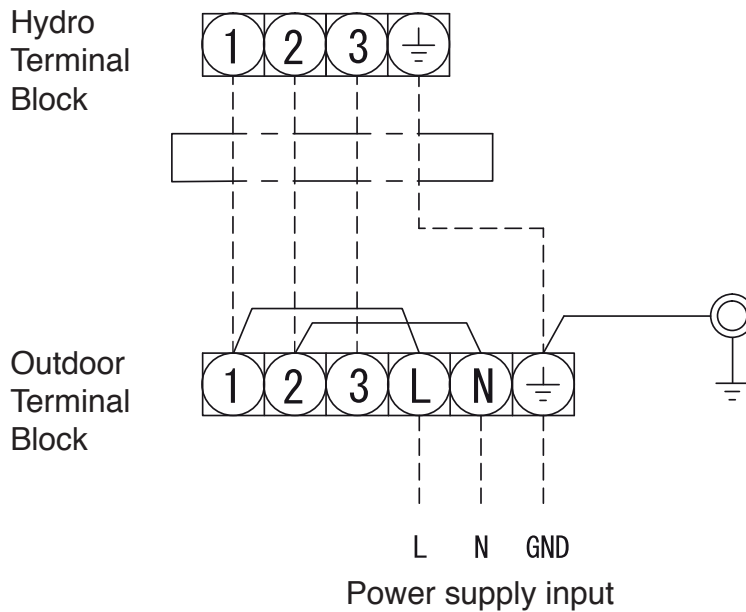

CAUTION

1. The power supply must be same as the rated of air to water heat pump.
 2. Prepare the power source for exclusive use with air to water heat pump.
 3. Circuit breaker must be used for the power supply line of this air to water heat pump.
 4. Be sure to comply power supply and connecting cable for size and wiring method.
 5. Every wire must be connected firmly.
 6. Perform wiring works so as to allow a general wiring capacity.
 7. Wrong wiring connection may cause some electrical part burn out.
 8. Incorrect or incomplete wiring is carried out, it will cause an ignition or smoke.
 9. This product can be connected to main power supply.
- Connection to fixed wiring : A switch which disconnects all poles and has a contact separation at least 3mm must be incorporated in the fixed wiring.

10-5. Others

10-5-1. Gas leak test

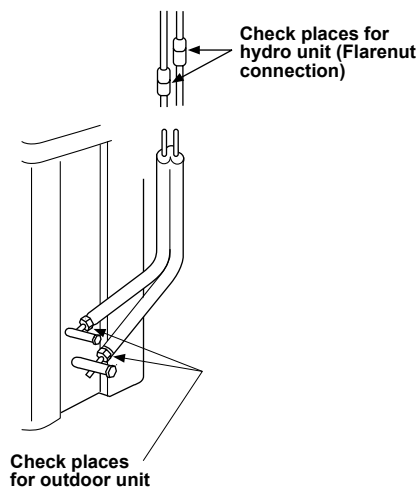

Fig. 10-5-1

- Check the flare nut connections for the gas leak with a gas leak detector or soap water.

11. HOW TO DIAGNOSE THE TROUBLE

Diagnose troubles according to the trouble diagnosis procedure as described below.
 (Refer to the check points in servicing written on the wiring diagrams attached to the hydro/outdoor units.)

Table 11-1

No.	Troubleshooting Procedure
1	First Confirmation
2	How to Diagnose Trouble in Outdoor Unit
3	How to Check Simply the Main Parts
4	How to Simply Judge Whether Outdoor Fan Motor is Good or Bad

◆ Precautions when handling the new inverter

⚠ CAUTION: HIGH VOLTAGEN

The high voltage circuit is incorporated.
 Be careful to do the check service, as the electric shock may be caused in case of touching parts on the P.C. board by hand.

The new inverter will be incorporated starting with this unit.

◆ The control circuitry has an uninsulated construction.

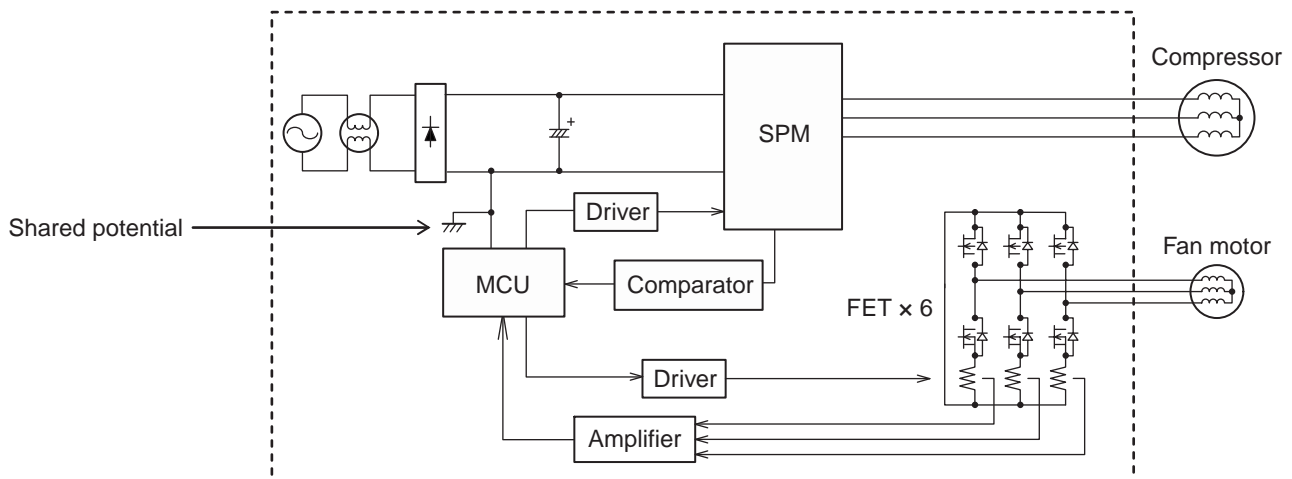

Fig. 11-1

⚠ CAUTION

A high voltage (equivalent to the supply voltage) is also energized to ground through the sensors, PMV and other low-voltage circuits. The sensor leads and other wires are covered with insulated tubes for protection. Nevertheless, care must be taken to ensure that these wires are not pinched.

Take sufficient care to avoid directly touching any of the circuit parts without first turning off the power.

At times such as when the circuit board is to be replaced, place the circuit board assembly in a vertical position.

Laying the board flat on an electrically conductive object (such as the top panel of the outdoor unit) while a charge is still retained by the electrolytic capacitors of the inverter's main circuit may cause short-circuiting between the electrolytic capacitors and secondary circuit components and result in damage to the components.

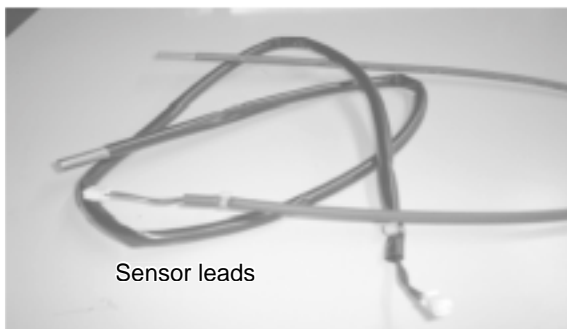

Sensor leads

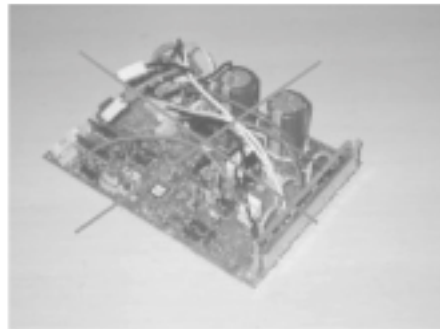

Fig. 11-2

Do NOT lay the circuit board assembly flat.

◆ Precautions when inspecting the control section of the outdoor unit

NOTE :

A large-capacity electrolytic capacitor is used in the outdoor unit controller (inverter). Therefore, if the power supply is turned off, charge (charging voltage DC280 to 380V) remains and discharging takes a lot of time. After turning off the power source, if touching the charging section before discharging, an electrical shock may be caused. Discharge the electrolytic capacitor completely by using soldering iron, etc.

< Discharging method >

1. Remove the inverter cover (plating) by opening four mounting claws.
2. As shown below, connect the discharge resistance (approx. 100Ω40W) or plug of the soldering iron to voltage between + – terminals of the C10 ("CAUTION HIGH VOLTAGE" is indicated.) electrolytic capacitor (760μF/400V) on P.C. board, and then perform discharging.

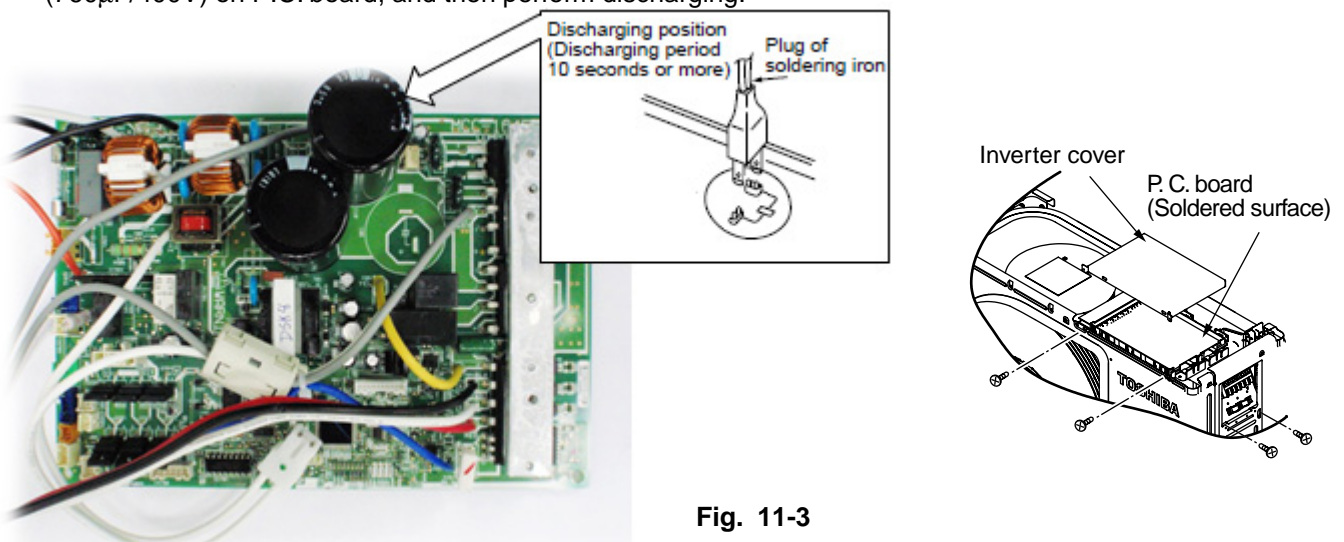

Fig. 11-3

11-1. First Confirmation

11-1-1. Confirmation of Power Supply

Confirm that the power breaker operates (ON) normally.

11-1-2. Confirmation of Power Voltage

Confirm that power voltage is AC 220–230 ± 10%.

If power voltage is not in this range, the unit may not operate normally.

11-1-3. Operation Which is not a Trouble (Program Operation)

For controlling the air to water heat pump, the program operations are built in the microcomputer as described in the following table.

If a claim is made for running operation, check whether or not it meets to the contents in the following table.

When it does, we inform you that it is not trouble of equipment, but it is indispensable for controlling and main-taining of air to water heat pump.

Table 11-1-1

No.	Operation of air to water heat pump	Description
1	Compressor may not operate even if the setting temperature is within range of compressor-ON.	The compressor does not operate while compressor restart delay timer (3-minutes timer) operates. The same phenomenon is found after power source has been turned on because 3-minutes timer operates.
2	In hot water supply or heating mode, the compressor motor speed does not increase up to the maximum speed or decreases before the temperature arrives at the set temperature.	The compressor motor speed may decrease by high-temp. release control (Release protective operation by temp.-up of the hydro heat exchanger) or current release control.
3	The "Stop" operation on the remote controller will not stop the circulation pump.	In order to deal with the temperature increase in the heat exchanger after stopping, the operation, continues for 1 min after compressor is stopped.
4	"ON" on the remote controller will not operate the compressor. (It will not operate even after the reboot delay timer elapsed.	When the outdoor temperature is -20°C or lower, the heat pump will not operate in order to protect the compressor, and the heater will operate in stead.
5	When the power is turned on, it starts operation without operating the remote controller.	<ul style="list-style-type: none"> • The auto restart operation may be working. • The antifreeze operation may be working.

11-2. How to Diagnose Trouble in Outdoor Unit

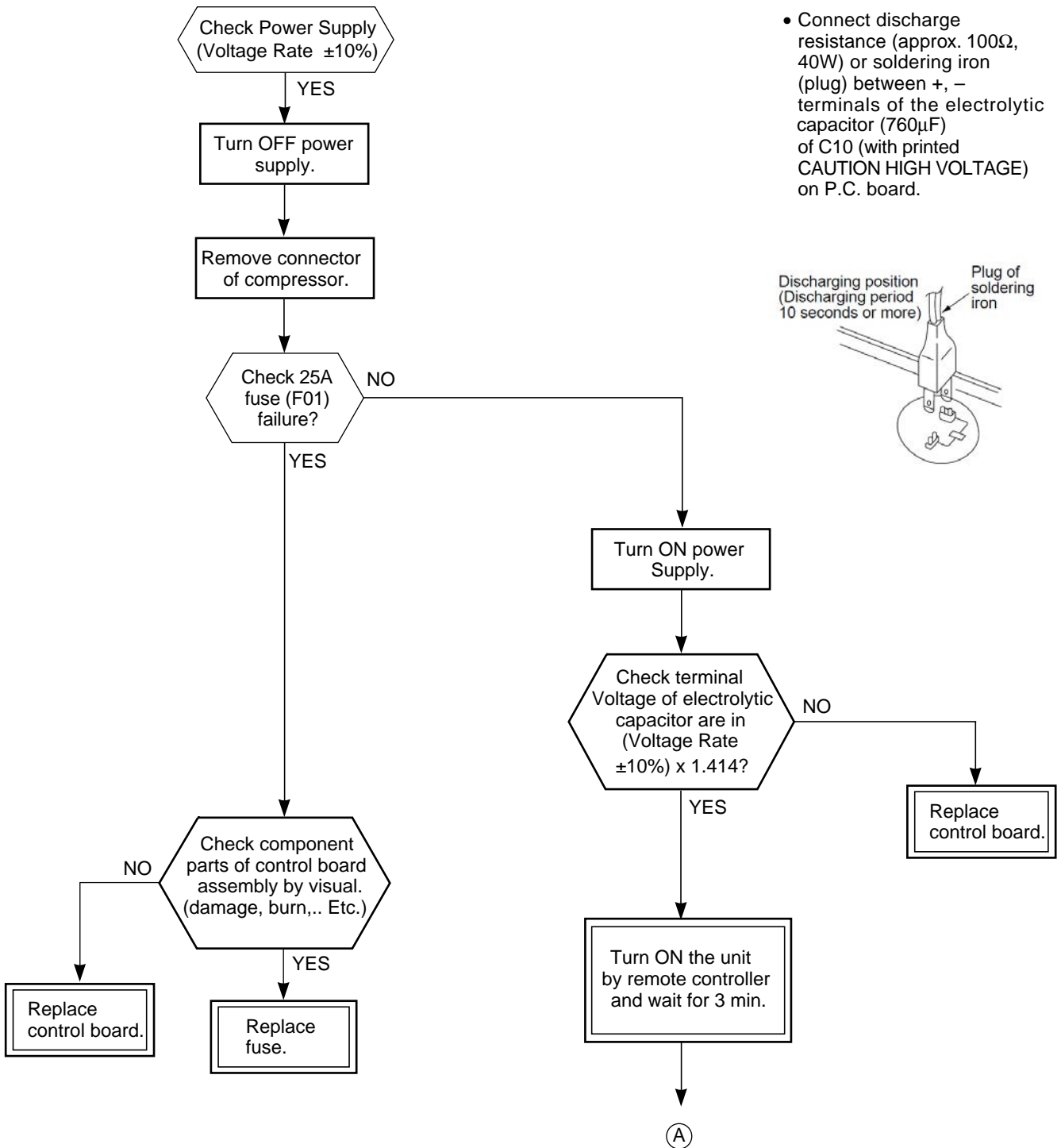

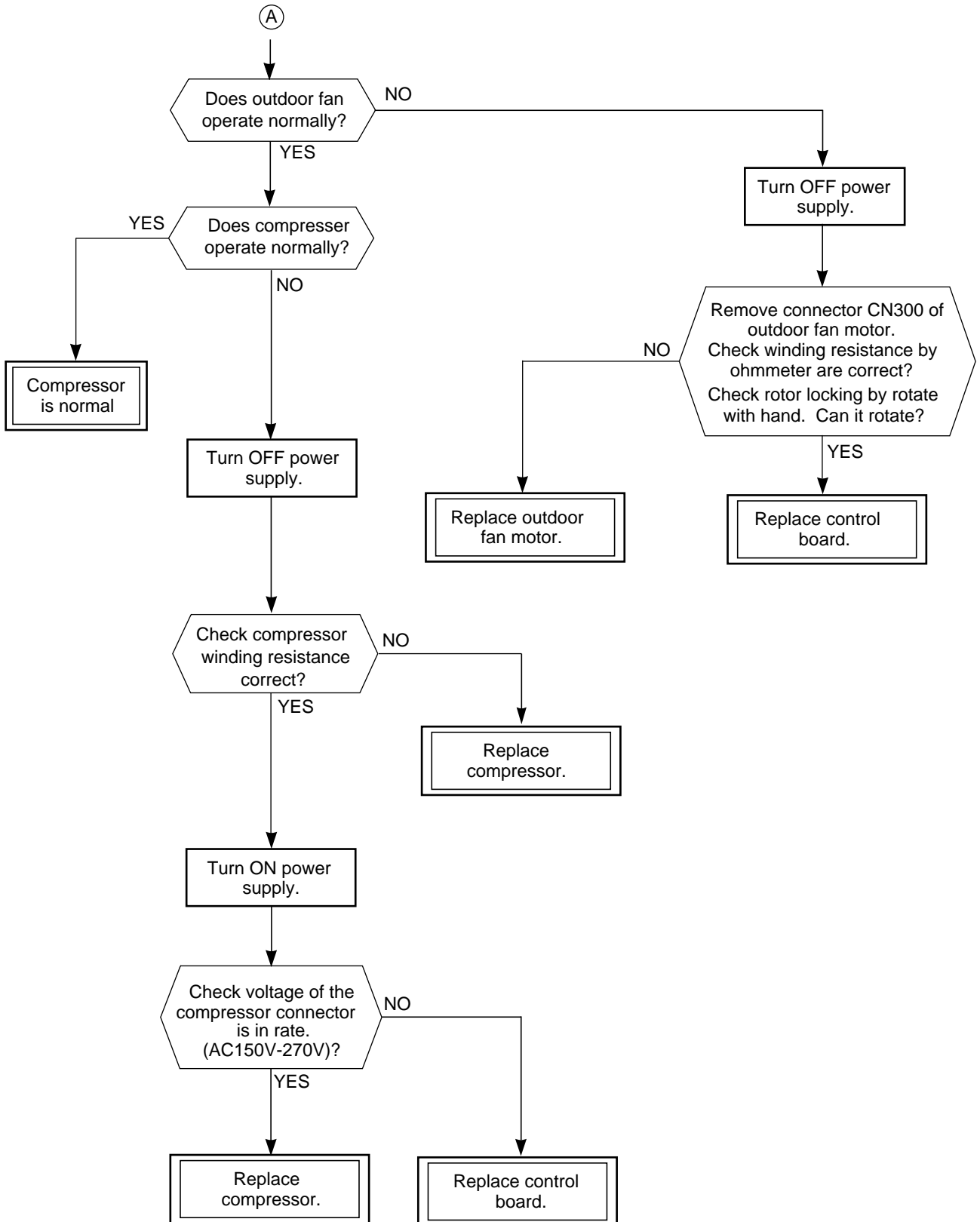

[1] Sensor characteristic table

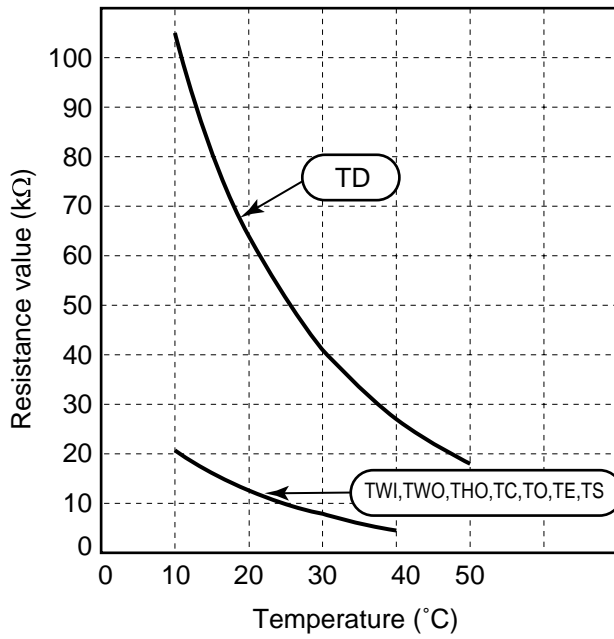

- TD : Discharge temp. sensor
- TWI, TWO, THO : Water temp. sensor
- TC : Heat exchanger temp. sensor
- TO : Outdoor temp. sensor
- TE : Outdoor heat exchanger temp. sensor
- TS : Suction temp. sensor

11-2-1. OutdoorUnit

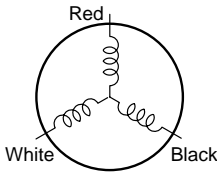
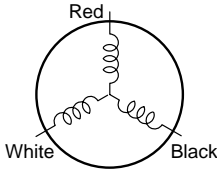
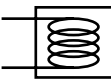
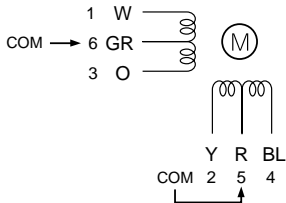
No.	Part name	Checking procedure																											
1	Compressor (Model : DA150A1T-21F)	Measure the resistance value of each winding by using the tester.  <table border="1" data-bbox="853 353 1420 504"> <thead> <tr> <th>Position</th> <th>Resistance value</th> </tr> </thead> <tbody> <tr> <td>Red - White</td> <td rowspan="3">1.13Ω</td> </tr> <tr> <td>White - Black</td> </tr> <tr> <td>Black - Red</td> </tr> </tbody> </table> <p style="text-align: right;">Under 20°C</p>	Position	Resistance value	Red - White	1.13Ω	White - Black	Black - Red																					
Position	Resistance value																												
Red - White	1.13Ω																												
White - Black																													
Black - Red																													
2	Outdoor fan motor (Model : ICF-140-43-4R)	Measure the resistance value of winding by using the tester.  <table border="1" data-bbox="853 600 1420 750"> <thead> <tr> <th>Position</th> <th>Resistance value</th> </tr> </thead> <tbody> <tr> <td>Red - White</td> <td rowspan="3">20 to 22Ω</td> </tr> <tr> <td>White - Black</td> </tr> <tr> <td>Black - Red</td> </tr> </tbody> </table>	Position	Resistance value	Red - White	20 to 22Ω	White - Black	Black - Red																					
Position	Resistance value																												
Red - White	20 to 22Ω																												
White - Black																													
Black - Red																													
3	4-way valve coil (Model : STF-H01AZ1724A1)	Measure the resistance value of winding by using the tester.  <table border="1" data-bbox="989 828 1420 907"> <thead> <tr> <th>Resistance value</th> </tr> </thead> <tbody> <tr> <td>7.1 ± 0.36Ω</td> </tr> </tbody> </table> <p style="text-align: right;">Under 20°C</p>	Resistance value	7.1 ± 0.36Ω																									
Resistance value																													
7.1 ± 0.36Ω																													
4	Pulse motor valve coil (Model : CAM-MD12TCTH-5)	Measure the resistance value of winding by using the tester.  <table border="1" data-bbox="989 1008 1420 1198"> <thead> <tr> <th>Position</th> <th>Resistance value</th> </tr> </thead> <tbody> <tr> <td>Gray - White</td> <td>43 to 49Ω</td> </tr> <tr> <td>Gray - Orange</td> <td>43 to 49Ω</td> </tr> <tr> <td>Red- Yellow</td> <td>43 to 49Ω</td> </tr> <tr> <td>Red- Blue</td> <td>43 to 49Ω</td> </tr> </tbody> </table> <p style="text-align: right;">Under 20°C</p>	Position	Resistance value	Gray - White	43 to 49Ω	Gray - Orange	43 to 49Ω	Red- Yellow	43 to 49Ω	Red- Blue	43 to 49Ω																	
Position	Resistance value																												
Gray - White	43 to 49Ω																												
Gray - Orange	43 to 49Ω																												
Red- Yellow	43 to 49Ω																												
Red- Blue	43 to 49Ω																												
5	Outdoor temperature sensor (TO), discharge temperature sensor (TD), suction temperature sensor (TS), outdoor heat exchanger temperature sensor (TE)	Disconnect the connector, and measure resistance value with the tester. (Normal temperature) <table border="1" data-bbox="598 1321 1420 1456"> <thead> <tr> <th rowspan="2">Sensor</th> <th colspan="6">Temperature</th> </tr> <tr> <th>10°C</th> <th>20°C</th> <th>25°C</th> <th>30°C</th> <th>40°C</th> <th>50°C</th> </tr> </thead> <tbody> <tr> <td>TD (kΩ)</td> <td>100</td> <td>64</td> <td>50</td> <td>41</td> <td>27</td> <td>18</td> </tr> <tr> <td>TO,TS,TE (kΩ)</td> <td>20.7</td> <td>12.6</td> <td>10.0</td> <td>7.9</td> <td>4.5</td> <td>—</td> </tr> </tbody> </table>	Sensor	Temperature						10°C	20°C	25°C	30°C	40°C	50°C	TD (kΩ)	100	64	50	41	27	18	TO,TS,TE (kΩ)	20.7	12.6	10.0	7.9	4.5	—
Sensor	Temperature																												
	10°C	20°C	25°C	30°C	40°C	50°C																							
TD (kΩ)	100	64	50	41	27	18																							
TO,TS,TE (kΩ)	20.7	12.6	10.0	7.9	4.5	—																							

11-2-2. Checking Method for Each Part

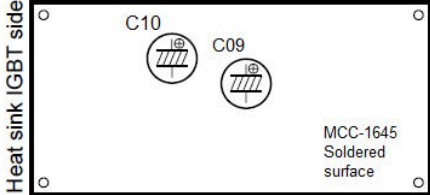
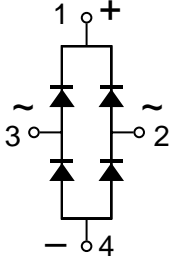
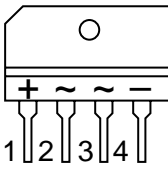
No.	Part name	Checking procedure												
1	Electrolytic capacitor (For boost, smoothing)	<p>1. Turn OFF the power supply breaker. 2. Discharge all two capacitors completely. 3. Check that safety valve at the bottom of capacitor is not broken. 4. Check that vessel is not swollen or exploded. 5. Check that electrolytic liquid does not blow off. 6. Check that the normal charging characteristics are shown in continuity test by the tester.</p> <div style="display: flex; justify-content: space-between; align-items: flex-start;"> <div style="border: 1px solid black; padding: 5px; width: 250px;"> <p style="font-size: small;">Heat sink IGBT side</p>  <p style="text-align: center;">C09, C10 → 760μF</p> </div> <div style="border: 1px solid black; padding: 5px; width: 200px;"> <p style="text-align: center;">Case that product is good</p> <p style="font-size: x-small;">Pointer swings once, and returns slowly. When performing test once again under another polarity, the pointer should return.</p> </div> </div>												
2	Diode block	<p>1. Turn OFF the power supply breaker. 2. Completely discharge the two electrolytic capacitors. 3. Remove the diode block from the PCB (which is soldered in place). 4. Use a multimeter with a pointer to test the continuity, and check that the diode block has the proper rectification characteristics.</p> <div style="display: flex; justify-content: space-around; align-items: flex-start;"> <div style="text-align: center;">  </div> <div style="text-align: center;">  <p>(DB01, DB02)</p> </div> <div style="border: 1px solid black; padding: 5px;"> <table border="1" style="width: 100%; text-align: center; font-size: x-small;"> <thead> <tr> <th colspan="2">Tester rod</th> <th rowspan="2">Resistance value in good product</th> </tr> <tr> <th>+</th> <th>-</th> </tr> </thead> <tbody> <tr> <td>~ 2</td> <td rowspan="2">+ 1</td> <td rowspan="4">∞</td> </tr> <tr> <td>~ 3</td> </tr> <tr> <td rowspan="2">- 4</td> <td>~ 2</td> </tr> <tr> <td>~ 3</td> </tr> </tbody> </table> <p style="font-size: x-small;">10 to 20 Ω when the multimeter probe is reversed</p> </div> </div>	Tester rod		Resistance value in good product	+	-	~ 2	+ 1	∞	~ 3	- 4	~ 2	~ 3
Tester rod		Resistance value in good product												
+	-													
~ 2	+ 1	∞												
~ 3														
- 4	~ 2													
	~ 3													

11-3. How to Simply Judge Whether Outdoor Fan Motor is Good or Bad

1. Symptom

- Outdoor fan motor does not rotate.
 - Outdoor fan motor stops within several tens seconds though it started rotating.
 - Outdoor fan motor rotates or does not rotate according to the position where the fan stopped, etc.
- Remote controller check code "02 : Outdoor block, 1A : Outdoor fan drive system error"

2. Cause

The following causes are considered when the outdoor fan motor does not normally rotate.

- 1) Mechanical lock of the outdoor fan motor
- 2) Winding failure of the outdoor fan motor
- 3) Position-detect circuit failure inside of the outdoor fan motor
- 4) Motor drive circuit failure of the outdoor P.C. board

3. How to simply judge whether outdoor fan motor is good or bad

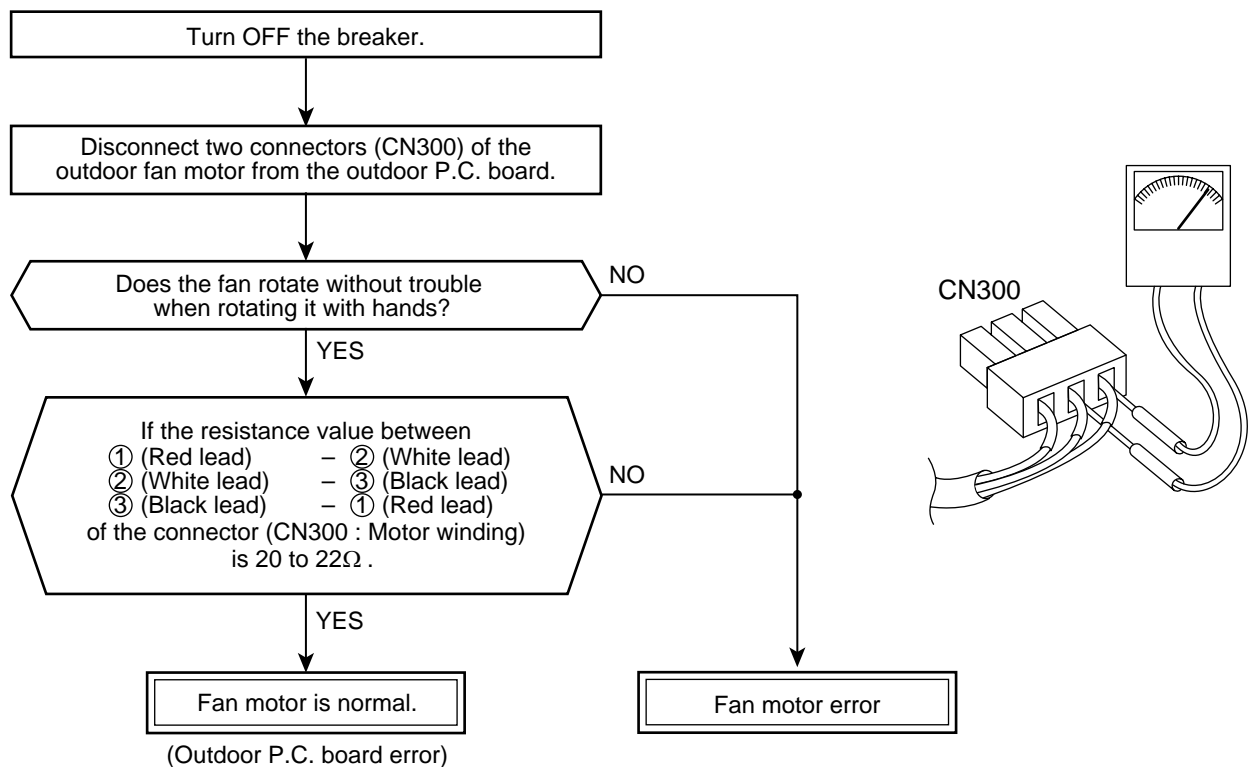

NOTE :

However, GND circuit error inside of the motor may be accepted in some cases when the above check is performed.

When the fan motor does not become normal even if P.C. board is replaced, replace the outdoor fan motor.

12. HOW TO REPLACE THE MAIN PARTS

WARNING

- Since high voltages pass through the electrical parts, turn off the power without fail before proceeding with the repairs.

Electric shocks may occur if the power plug is not disconnected.

- After the repairs have been completed (after the front panel and cabinet have been installed), perform a test run, and check for smoking, unusual sounds and other abnormalities.

If this check is omitted, a fire and/or electric shocks may occur.

Before proceeding with the test run, install the front panel and cabinet.

- Ensure that the following steps are taken when doing repairs on the refrigerating cycle.

1. Do not allow any naked flames in the surrounding area.

If a gas stove or other appliance is being used, extinguish the flames before proceeding.

If the flames are not extinguished, they may ignite any oil mixed with the refrigerant gas.

2. Do not use welding equipment in an airtight room.

Carbon monoxide poisoning may result if the room is not properly ventilated.

3. Do not bring welding equipment near flammable objects.

Flames from the equipment may cause the flammable objects to catch fire.

- **If keeping the power on is absolutely unavoidable while doing a job such as inspecting the circuitry, wear rubber gloves to avoid contact with the live parts.**

Electric shocks may be received if the live parts are touched.

High-voltage circuits are contained inside this unit.

Proceed very carefully when conducting checks since directly touching the parts on the control circuit board may result in electric shocks.

Outdoor Unit

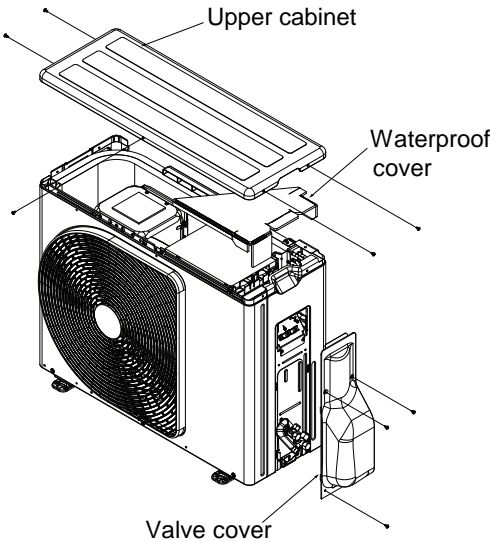
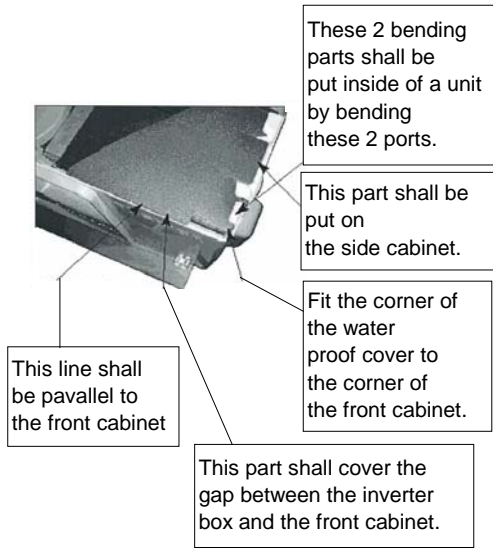
No.	Part name	Procedure	Remarks
①	Common procedure	<p>1. Detachment</p> <div style="border: 1px solid black; padding: 5px; margin: 10px 0;"> <p align="center">NOTE</p> <p>Wear gloves for this job. Otherwise, you may injure your hands on the parts, etc.</p> </div> <ol style="list-style-type: none"> 1) Stop operation of the air to water heat pump system, and turn off the main switch of the breaker for air to water heat pump system. 2) Remove the valve cover. (ST1TØ4 x 10L 3 pcs.) <ul style="list-style-type: none"> • After removing screw, remove the valve cover pulling it downward. 3) Remove cord clamp (ST2TØ4 x 14L 3 pcs.), and then remove connecting cable. 4) Remove the upper cabinet. (ST1TØ4 x 10L 5 pcs.) <ul style="list-style-type: none"> • After removing screws, remove the upper cabinet pulling it upward. <p>2. Attachment</p> <ol style="list-style-type: none"> 1) Attach the water-proof cover. <div style="border: 1px solid black; padding: 5px; margin: 10px 0;"> <p align="center">NOTE</p> <p>The water-proof cover must be attached without fail in order to prevent rain water, etc. from entering inside the hydro unit.</p> </div> <ol style="list-style-type: none"> 2) Attach the upper cabinet. (ST1TØ4 x 10L 5 pcs.) 3) Perform cabling of connecting cable, and attach the cord clamp. <ul style="list-style-type: none"> • Fix the cord clamp by tightening the screws (ST2TØ 4 x 14L 3 pcs.), fitting 2 concave parts of the cord clamp to each connecting cables. 4) Attach the valve cover. (ST1TØ 4 x 10L 3 pcs.) <ul style="list-style-type: none"> • Insert the upper part into the square hole of the side cabinet, set hook claws of the valve cover to square holes (at three positions) of the main unit, and attach it pushing upward, 	 <p>Upper cabinet</p> <p>Waterproof cover</p> <p>Valve cover</p>  <p>These 2 bending parts shall be put inside of a unit by bending these 2 ports.</p> <p>This part shall be put on the side cabinet.</p> <p>Fit the corner of the water proof cover to the corner of the front cabinet.</p> <p>This part shall cover the gap between the inverter box and the front cabinet.</p> <p>This line shall be pavallel to the front cabinet</p> <div style="border: 1px solid black; padding: 5px; margin-top: 10px;"> <p align="center">How to mount the water-proof cover</p> </div>

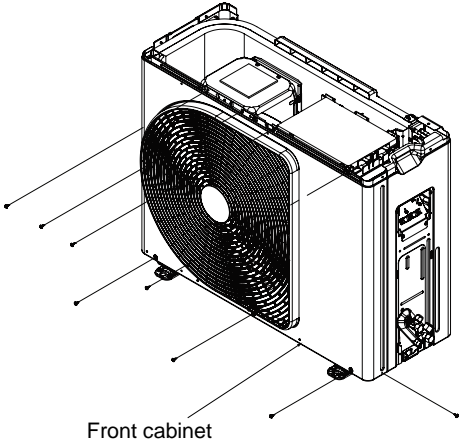
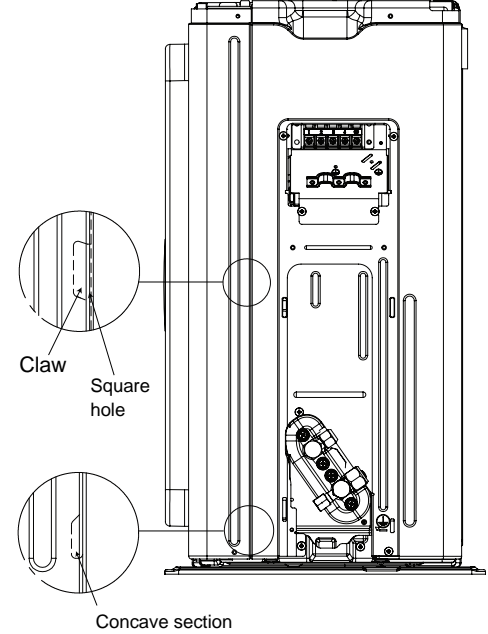
No.	Part name	Procedure	Remarks
②	Front cabinet	<p>1. Detachment</p> <ol style="list-style-type: none"> 1) Perform step 1 in ①. 2) Remove the fixing screws (ST1TØ4 × 10L 2 pcs.) used to secure the front cabinet and inverter cover, the screws (ST1TØ4 × 10L 4 pcs.) used to secure the front cabinet at the bottom, and the fixing screws (ST1TØ4 × 10L 2 pcs.) used to secure the motor base. <ul style="list-style-type: none"> • The front cabinet is fitted into the side cabinet (left) at the front left side so pull up the top of the front cabinet to remove it. <p>2. Attachment</p> <ol style="list-style-type: none"> 1) Insert the claw on the front left side into the side cabinet (left). 2) Hook the bottom part of the front right side onto the concave section of the bottom plate. Insert the claw of the side cabinet (right) into the square hole in the front cabinet. 3) Return the screws that were removed above to their original positions and attach them. 	 <p>Front cabinet</p>  <p>Claw Square hole</p> <p>Concave section</p>

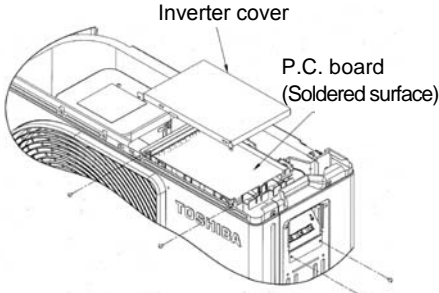
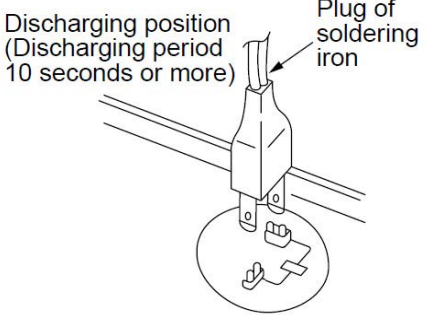
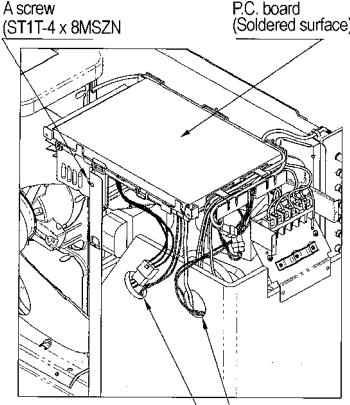
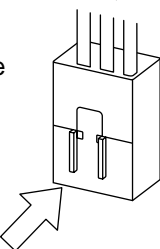
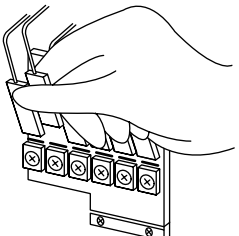
No.	Part name	Procedure	Remarks
③	Inverter assembly	<p>1) Perform work of item 1 in ①.</p> <p>2) Remove screw (ST1TØ4 x 10L 2 pcs.) of the upper part of the front cabinet.</p> <ul style="list-style-type: none"> • If removing the inverter cover in this condition, P.C. board can be checked. • If there is no space above the unit, perform work of 1 in ②. <div style="border: 1px solid black; padding: 5px; margin: 10px 0;"> <p>Be careful to check the inverter because high-voltage circuit is incorporated in it.</p> </div> <p>3) Perform discharging by connecting ⊕, ⊖ polarity by discharging resistance (approx. 100Ω40W) or plug of soldering iron to ⊕, ⊖ terminals a of the C10 (printed "CAUTION HIGH VOLTAGE" is attached.) electrolytic capacitor (760μF) on P.C. board.</p> <div style="border: 1px solid black; padding: 5px; margin: 10px 0;"> <p>Be careful to discharge the capacitor because the electrolytic capacitor cannot naturally discharge and voltage remains according to trouble type in some cases.</p> </div> <div style="text-align: center; margin: 10px 0;"> <p>NOTE</p> <p>This capacitor is one with mass capacity. Therefore, it is dangerous that a large spark generates if short-circuiting between ⊕, ⊖</p> </div> <p>4) Remove screw (ST1TØ4 x 10L 4pcs.) fixing the terminal part of inverter box to the main body.</p> <p>5) Remove the front cabinet by performing step 1 in ②, and remove the fixing screws (ST1TØ4 x 10L) for securing the main body and inverter box.</p> <p>6) Remove various lead wires from the holder at upper part of the inverter box.</p> <p>7) Pull the inverter box upward.</p> <p>8) Disconnect connectors of various lead wires.</p> <div style="border: 1px solid black; padding: 5px; margin: 10px 0;"> <p style="text-align: center;">Requirement</p> <p>As each connector has a lock mechanism, avoid to remove the connector by holding the lead wire, but by holding the connector.</p> </div>	 <p>Inverter cover P.C. board (Soldered surface)</p>  <p>Discharging position (Discharging period 10 seconds or more) Plug of soldering iron</p>  <p>A screw (ST1T-4 x 8MSZN) P.C. board (Soldered surface)</p> <p>Put the compressor leads through the hole. Put each leads through the hole.</p>  <p>The connector is one with lock, so remove it while pushing the part indicated by an arrow.</p>  <p>Be sure to remove the connector by holding the connector, not by pulling the lead wire.</p>

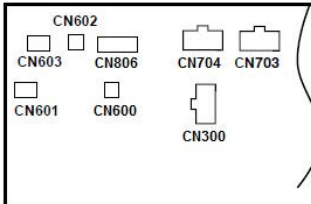
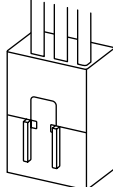
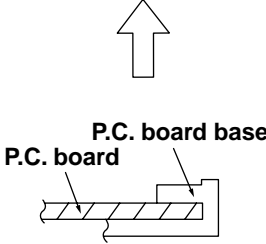
No.	Part name	Procedure	Remarks
④	Control board assembly	<p>1. Disconnect the leads and connectors connected to the other parts from the control board assembly.</p> <p>1) Leads</p> <ul style="list-style-type: none"> • 3 leads (black, white, orange) connected to terminal block. • Lead connected to compressor : Disconnect the connector (3P). • Lead connected to reactor : Disconnect the two connectors (2P). <p>2) Connectors</p> <p>CN300 : Outdoor fan motor (3P: white) CN600 : TE sensor (2P: white)* CN700 : PMV (6P: white) CN603 : TS sensor (3P: white)* CN601 :TD sensor (3P: white)* CN602 : TO sensor (2P: white) CN704 : 4 Way valve (2P: White) CN501 : High pressure switch (3P: Green)</p> <div style="border: 1px solid black; padding: 5px; margin: 10px 0; text-align: center;">NOTE</div> <p>These connectors have a disconnect prevention mechanism: as such, the lock on their housing must be released before they are disconnected.</p> <p>2. Remove the control board assembly from the P.C. board base. (Remove the heat sink and control board assembly while keeping them screwed together.)</p> <div style="border: 1px solid black; padding: 5px; margin: 10px 0; text-align: center;">NOTE</div> <p>Disengage the four claws of the P.C. board base, hold the heat sink, and lift to remove it.</p> <p>3. Remove the two fixing screws used to secure the heat sink and control board assembly.</p> <p>4. Mount the new control board assembly.</p> <div style="border: 1px solid black; padding: 5px; margin: 10px 0; text-align: center;">NOTE</div> <p>When mounting the new control board assembly, ensure that the P.C. board is inserted properly into the P.C. board support groove.</p>	 <p>Connectors with locking mechanisms: as such, to disconnect them, they must be pressed in the direction of the arrow while pulling them out.</p>  

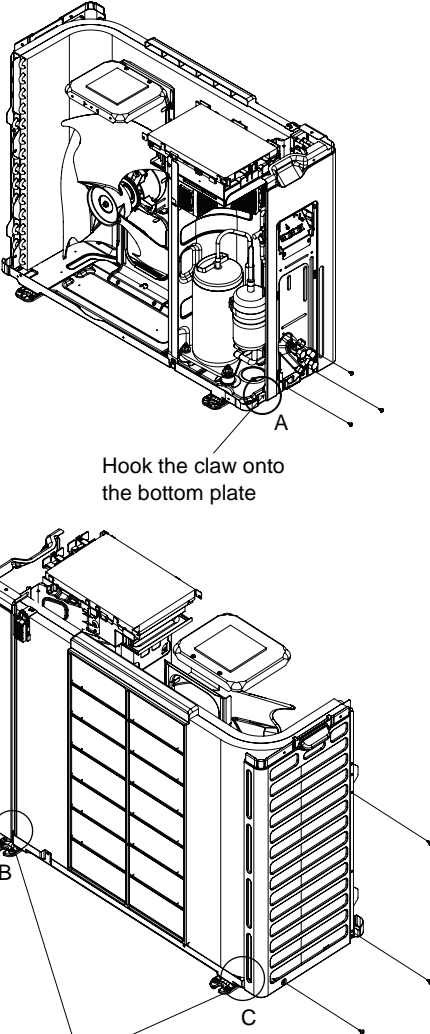
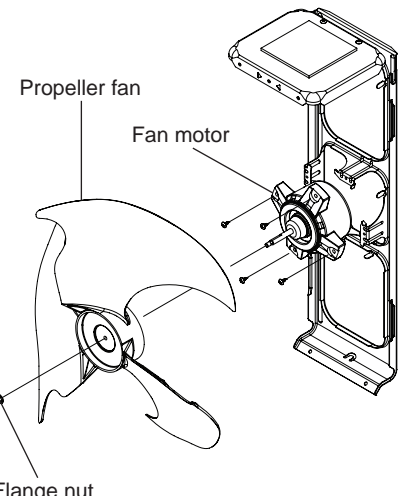
No.	Part name	Procedure	Remarks
⑤	Side cabinet	<p>1. Side cabinet (right)</p> <ol style="list-style-type: none"> 1) Perform step 1 in ② and all the steps in ③. 2) Remove the fixing screw (ST1TØ4 × 10L 3 pcs.) used for securing the side cabinet to the bottom plate and valve fixing panel. <p>2. Side cabinet (left)</p> <ol style="list-style-type: none"> 1) Perform step 1 in ②. 2) Remove the fixing screw (ST1TØ4 × 10L 1 pc.) used to secure the side cabinet (left) onto the heat exchanger. 3) Remove the fixing screw (ST1TØ4 × 10L 2 pcs.) used for securing the side cabinet to the bottom plate and heat exchanger. 	
⑥	Fan motor	<ol style="list-style-type: none"> 1) Perform work of item 1 of ① and ②. 2) Remove the flange nut fixing the fan motor and the propeller. <ul style="list-style-type: none"> • Flange nut is loosened by turning clockwise. (To tighten the flange nut, turn counterclockwise.) 3) Remove the propeller fan. 4) Disconnect the connector for fan motor from the inverter. 5) Remove the fixing screws (4 pcs.) holding by hands so that the fan motor does not fall. <p>* Precautions when assembling the fan motor Tighten the flange nut using a tightening torque of 4.9 N•m.</p>	

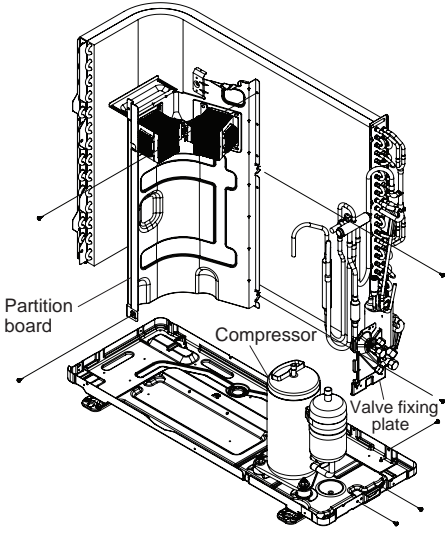
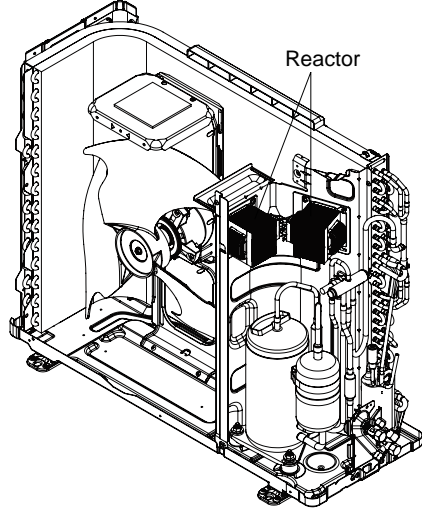
No.	Part name	Procedure	Remarks
⑦	Compressor	<ol style="list-style-type: none"> 1) Perform work of item 1 of ① and ②, ③, ④, ⑤. 2) Extract refrigerant gas. 3) Remove the partition board. (ST1TØ4 × 10L 4 pcs.) 4) Remove the sound-insulation material. 5) Remove terminal cover of the compressor, and disconnect lead wire of the compressor from the terminal. 6) Remove pipe connected to the compressor with a burner. <ul style="list-style-type: none"> • Take care to keep the 4-way valve away from naked flames. (Otherwise, it may malfunction.) 7) Remove the fixing screw of the bottom plate and heat exchanger. (ST1TØ4 × 10L 1 pc.) 8) Remove the fixing screw of the bottom plate and valve fixing plate. (ST1TØ4 × 10L 2 pcs.) 9) Pull upward the refrigeration cycle. 10) Remove NUT (3 pcs.) fixing the compressor to the bottom plate. 	
⑧	Reactor	<ol style="list-style-type: none"> 1) Perform work of item 1 of ②, and ③. 2) Remove screws fixing the reactors. (ST1TØ4 × 10L 4 pcs.) 	

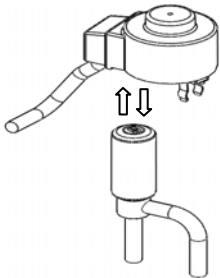
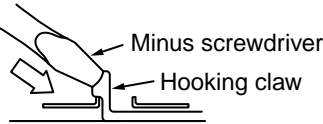
No.	Part name	Procedure	Remarks
⑨	Electronic expansion valve coil	<p>1. Detachment</p> <ol style="list-style-type: none"> 1) Perform step 1 in ②, all the steps in ③ and 1 in ⑤. 2) Remove the coil by pull it upward. <p>2. Attachment</p> <ol style="list-style-type: none"> 1) Insert a valve coil to value body by push it downward. And confirm to fix it surely. 	
⑩	Fan guard	<p>1. Detachment</p> <ol style="list-style-type: none"> 1) Perform work of item 1 of ②. 2) Remove the front cabinet, and put it down so that fan guard side directs downward. <div style="border: 1px solid black; padding: 5px; margin: 10px 0;"> <p>Perform work on a corrugated cardboard, cloth, etc. to prevent flaw to the product.</p> </div> <ol style="list-style-type: none"> 3) Remove the hooking claws by pushing minus screwdriver according to the arrow mark in the right figure, and remove the fan guard. <p>2. Attachment</p> <ol style="list-style-type: none"> 1) Insert claws of the fan guard in the holes of the front cabinet. Push the hooking claws (9 positions) by hands and fix the claws. <div style="border: 1px solid black; padding: 5px; margin: 10px 0;"> <p>Check that all the hooking claws are fixed to the specified positions.</p> </div>	

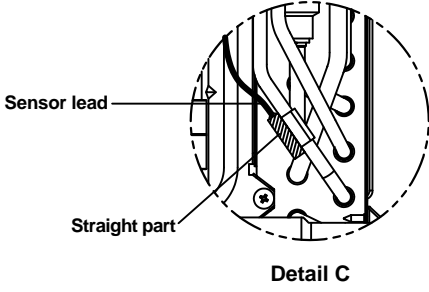
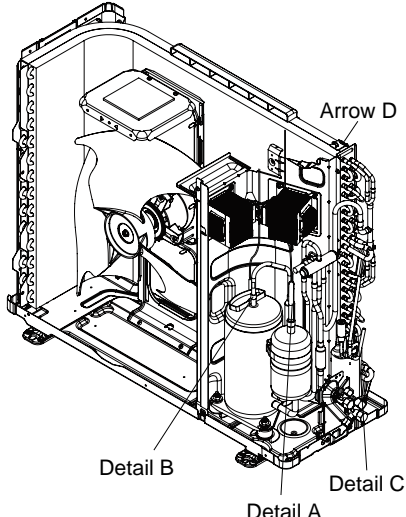
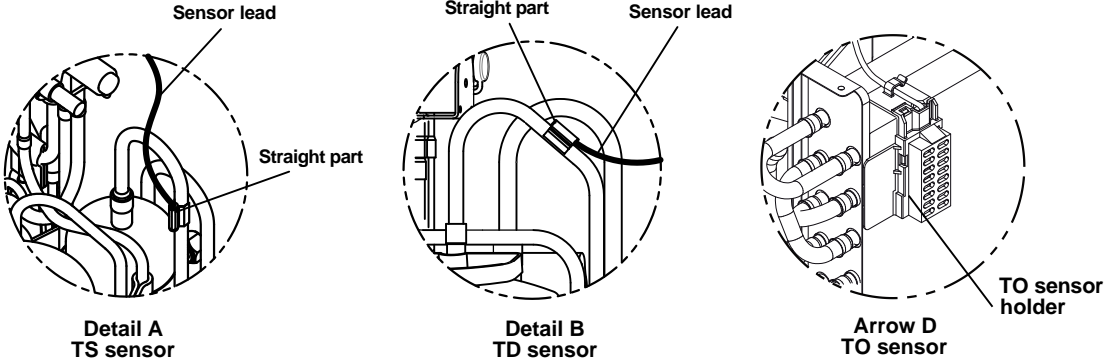
No.	Part name	Procedure	Remarks
⑪	TE sensor (outdoor heat exchanging temperature sensor) • Attachment Install the sensor onto the straight pipe part of the condenser output pipe.	 <p style="text-align: center;">Detail C</p>	
⑫	TS sensor (Suction pipe temperature sensor) • Attachment Install the sensor onto the straight pipe part of the suction pipe. Be careful for the lead direction of the sensor.		
⑬	TD sensor (Discharge pipe temperature sensor) • Attachment With its leads pointed upward, install the sensor onto the vertical straight pipe part of the discharge pipe.		
⑭	TO sensor (Outside air temperature sensor) • Attachment Insert the outdoor air temperature sensor into the holder, and install the holder onto the heat exchanger.	 <p style="text-align: center;"> Detail A TS sensor Detail B TD sensor Arrow D TO sensor </p>	<div style="text-align: center; border: 1px solid black; padding: 5px; margin-bottom: 10px;"> CAUTION </div> <p>During the installation work (and on its completion), take care not to damage the coverings of the sensor leads on the edges of the metal plates or other parts. It is dangerous for these coverings to be damaged since damage may cause electric shocks and/or a fire.</p> <div style="text-align: center; border: 1px solid black; padding: 5px; margin-bottom: 10px;"> CAUTION </div> <p>After replacing the parts, check whether the positions where the sensors were installed are the proper positions as instructed. The product will not be controlled properly and trouble will result if the sensors have not been installed in their proper positions.</p>

No.	Part name	Procedure	Remarks																												
<p>⑮</p> <p>Replacement of temperature sensor for servicing only</p> <p>Common service parts of sensor TO, TS, TE, TD</p> <p>These are parts for servicing sensors. Please check that the accessories shown in the right table are packed.</p>		<ol style="list-style-type: none"> 1) Cut the sensor 100 mm longer than old one. 2) Cut the protective tube after pulling out it (200 mm). 3) Move the protective tube toward the thermal sensor side and tear the tip of lead wire in two then strip the covering part. 4) Pass the stripped part through the thermal constringent tube. 5) Cut the old sensor 100 mm length on the connector side, and recycle that connector. 6) Tear the lead wire in two on the connector side and strip the covering part. 7) Twist the leads on the connector and sensor sides, and solder them. 8) Move the thermal constringent tubes toward the soldered parts and heat them with the dryer and constring them. 9) Wind the attached color tape round the both terminals of the protective tube when colored protective tube is used. 10) Fix the sensor again. <div style="text-align: center; border: 1px solid black; padding: 5px; margin: 10px 0;"> <p>NOTE</p> <ol style="list-style-type: none"> 1) Store the joint part of the sensor and the connector in the electric parts box. 2) Never joint them near the thermal sensor part. Otherwise it would cause insulation inferiority because of dew drops. 3) When replacing the sensor using the colored protective tube, wind the color tape matching the color of that tube. </div> <table border="1" style="width: 100%; border-collapse: collapse; margin-top: 10px;"> <thead> <tr> <th style="width: 5%;">Q'ty</th> <th style="width: 65%;">Parts name</th> <th style="width: 10%;">Q'ty</th> <th style="width: 20%;">Remarks</th> </tr> </thead> <tbody> <tr> <td style="text-align: center;">1</td> <td>Sensor</td> <td style="text-align: center;">1</td> <td>Length : 3m</td> </tr> <tr> <td style="text-align: center;">2</td> <td>Sensor Spring (A)</td> <td style="text-align: center;">1</td> <td>For spare</td> </tr> <tr> <td style="text-align: center;">3</td> <td>Sensor Spring (B)</td> <td style="text-align: center;">1</td> <td>For spare</td> </tr> <tr> <td style="text-align: center;">4</td> <td>Thermal constringent tube</td> <td style="text-align: center;">3</td> <td>Including one spare</td> </tr> <tr> <td style="text-align: center;">5</td> <td>Color tape</td> <td style="text-align: center;">1</td> <td>9 colors</td> </tr> <tr> <td style="text-align: center;">6</td> <td>Terminal</td> <td style="text-align: center;">3</td> <td></td> </tr> </tbody> </table>	Q'ty	Parts name	Q'ty	Remarks	1	Sensor	1	Length : 3m	2	Sensor Spring (A)	1	For spare	3	Sensor Spring (B)	1	For spare	4	Thermal constringent tube	3	Including one spare	5	Color tape	1	9 colors	6	Terminal	3		
Q'ty	Parts name	Q'ty	Remarks																												
1	Sensor	1	Length : 3m																												
2	Sensor Spring (A)	1	For spare																												
3	Sensor Spring (B)	1	For spare																												
4	Thermal constringent tube	3	Including one spare																												
5	Color tape	1	9 colors																												
6	Terminal	3																													

13. EXPLODED VIEWS AND PARTS LIST

13-1. Outdoor Unit

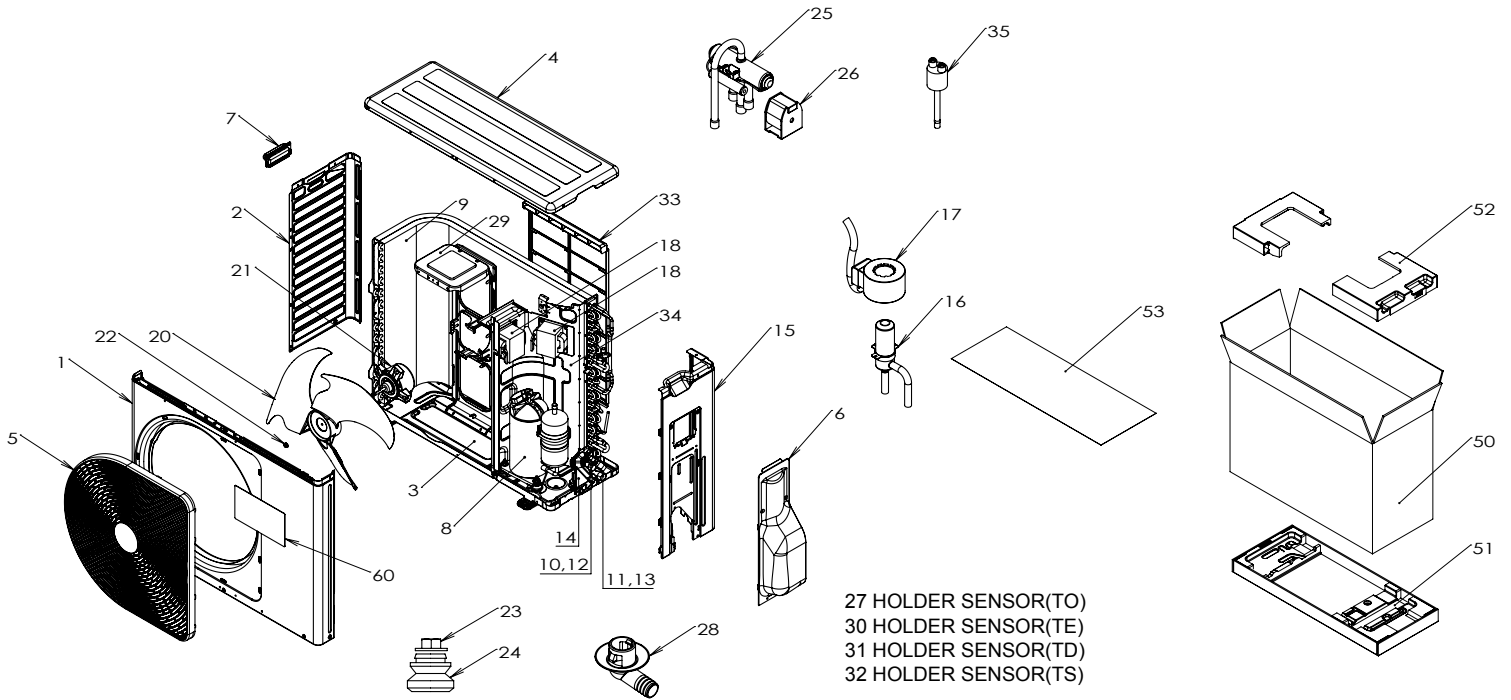

Location No.	Part No.	Description	Location No.	Part No.	Description
1	43T00718	FRONT CABINET	22	43T47001	NUT FLANGE
2	43T00560	LEFT CABINET	23	43T97001	NUT
3	43T42345	BASE PLATE ASSEMBLY	24	43T49335	RUBBER CUSHION
4	43T00561	UPPER CABINET	25	43T46375	4 WAY VALVE
5	43T19371	FAN GUARD	26	43T63352	COIL-V-4WAY
6	43T00762	PACKED VALVE COVER ASSEMBLY	27	43T63319	HOLDER,SENSOR
7	43T19350	HANDLE	28	43T79305	DRAIN NIPPLE
8	43T41471	COMPRESSOR	29	43T39341	MOTOR BASE CONNECTION PLATE
9	43T43458	CONDENSOR ASSEMBLY	30	43T63318	HOLDER SENSOR
10	43T46358	VALVE;PACKED 6.35 DIA	31	43T63317	HOLDER,SENSOR
11	43T46374	VALVE;PACKED 12.7DIA(H4)	32	43T63316	HOLDER,SENSOR
12	43T47331	BONNET, 6.35 DIA	33	43T19351	FIN GUARD
13	43T47333	BONNET, 12.70 DIA	34	43T04343	PARTITION ASSEMBLY
14	43T00448	FIXING PLATE VALVE	35	43T63370	SW-PRESS
15	43T00719	RIGHT SIDE CABINET ASSEMBLY	50	43T91340	CARTON BOX
16	43T46347	BODY PMV	51	43T91338	FIBERBOARD UNDER ASSEMBLY
17	43T63329	COIL PMV	52	43T91337	CUSHION PACKING UPPER
18	43T58327	REACTOR	53	43T91301	PE SHEET
20	43T20331	PROELLER FAN	60	43T85684	MARK-T (ESTIA)
21	43T21375	FAN MOTOR			

13-2. P.C. Board Layout

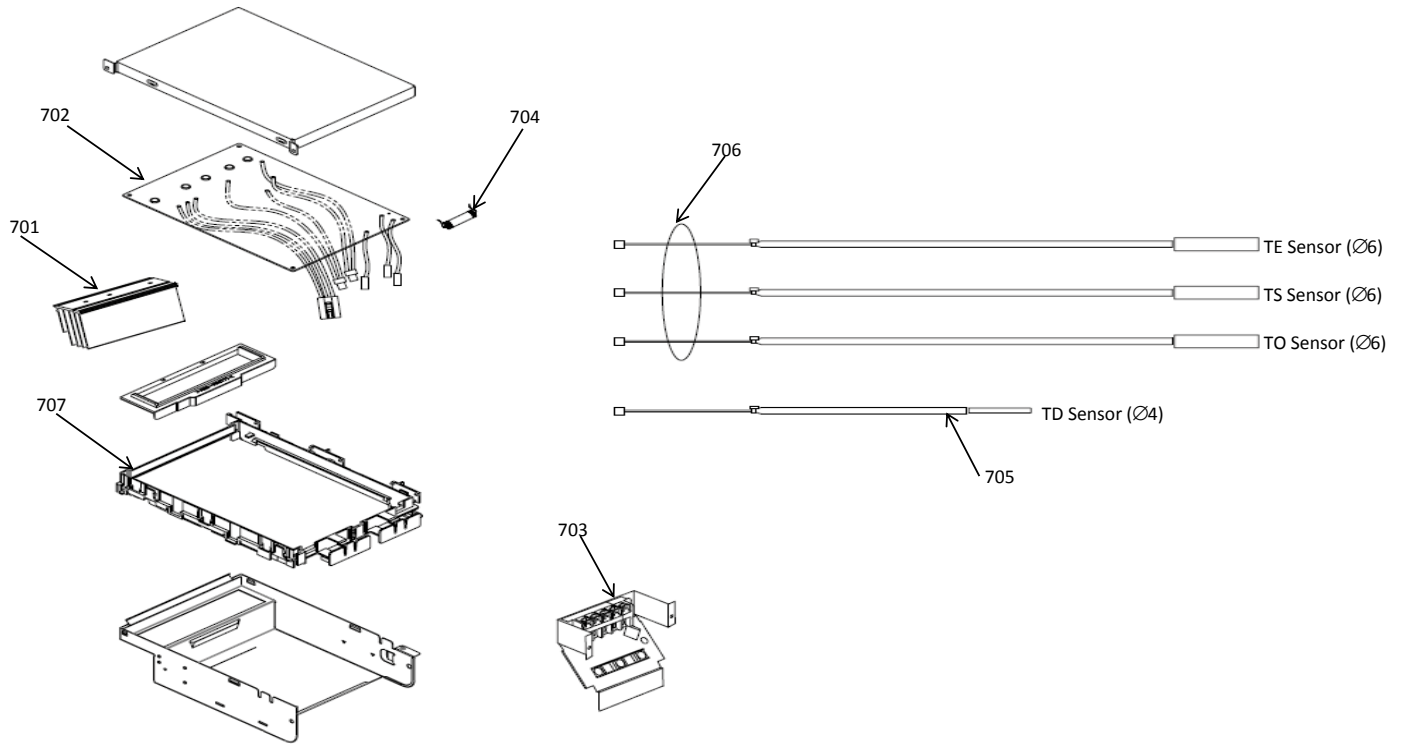

Location No.	Part No.	Description	Location No.	Part No.	Description
701	43T62353	HEATSINK	705	43T50334	TEMPERATURE SENSOR
702	43T6V925	PC BOARD	706	43T50304	SENSOR;HEAT EXCHANGER
703	43T60384	TERMINAL-6P	707	43T62313	PC PLATE BASE
704	43T60326	FUSE			

TOSHIBA CARRIER (THAILAND) CO.,LTD.

**144/9 MOO 5, BANGKADI INDUSTRIAL PARK, TIVANON ROAD, TAMBOL BANGKADI,
AMPHUR MUANG, PATHUMTHANI 12000, THAILAND.**