



Mini-SMMS

Mini-SMMS



VRF DX COIL INTERFACE Installation manual

Model name:

For Commercial use

- MM-DXC010 VRF DX COIL CONTROLLER (Individual / Header)
- MM-DXC012 VRF DX COIL CONTROLLER (Follower)
- MM-DXV080 VRF DX COIL VALVE KIT (5.6kW, 7.1kW, 8.0kW)
- MM-DXV140 VRF DX COIL VALVE KIT (11.2kW, 14.0kW, 16.0kW)
- MM-DXV280 VRF DX COIL VALVE KIT (22.4kW, 28.0kW)

ENGLISH



Please read this Installation Manual carefully before installing the VRF DX Coil interface.

- This Manual describes the installation method of the VRF DX Coil interface.
- You must also refer to the Installation and Owner's Manual attached to the Toshiba outdoor unit.
- Please follow the manual(s) for your Air Handling Unit (local supply).
- Toshiba Carrier UK (Ltd) does not take any responsibility on the local design.

ADOPTION OF NEW REFRIGERANT

This Air Conditioner is a new type which adopts a new refrigerant HFC (R410A) instead of the conventional refrigerant R22 in order to prevent destruction of the ozone layer.

This appliance is for commercial use only and should not be accessible to the general public. This appliance is not intended for use by person (including children) with reduced physical, sensory or mental capabilities, or lack of experience and knowledge, unless they have been given supervision or instruction concerning use of the appliance by a person responsible for their safety. Children should be supervised to ensure that they do not play with the appliance.

Contents

1	OVERVIEW: VRF DX INTERFACE (GROUP)	2
2	SUPPLIED PARTS	3
3	PRECAUTIONS FOR SAFETY	3
4	INSTALLATION	4
5	ELECTRICAL WORK	14
6	APPLICABLE CONTROLS	21
7	TEST RUN	23
8	TROUBLE SHOOTING	24
9	OPTIONAL PARTS	25
10	DECLARATION OF CONFORMITY	26
11	SERVICE PARTS	27

This symbol mark is for EU countries only.

This symbol mark is according to the directive 2002/96/EC Article 10 Information for users and Annex IV.

This product is designed and manufactured with high quality materials and components which can be recycled and reused.

This symbol means that electrical and electronic equipment, at the end-of-life, should be disposed of separately from your household waste.

Please dispose of this equipment at your local community waste collection / recycling centre.

In the European Union there are separate collection systems for used electrical and electronic product.



1 OVERVIEW: VRF DX INTERFACE (GROUP)

The VRF DX Coil Interface enables a DX-Coil from an air handling unit to be connected to a Toshiba VRF system (MiNi-SMMS / MiNi-SMMSe / SMMS / SMMSi / SMMSe / SHRM / SHRMi / SHRMe). There are 2 components: DX-Coil Controller and a DX Coil Valve Kit (including a Pulse Modulating Valve). DX-Coil Controllers are available as a Individual / Header (MM-DXC010) or as a Follower (MM-DXC012). There are 3 models of valve kits: MM-DXV080 (2-3HP) / MM-DXV140 (4-6HP) / MM-DXV280 (8-10HP). When configured as an “Individual” the MM-DXC010 has a capacity range of 2-10HP (plus appropriate valve kit). For larger capacities up to 60HP (SMMSe) the MM-DXC010 is configured as a “Header” and grouped in combination with 1-5 x MM-DXC012 “Followers” (plus appropriate valve kit). DX Coils >10HP must be split into separate pathways (Distributors and Headers) for each section.

Example AHU with DX-Interface (30HP)

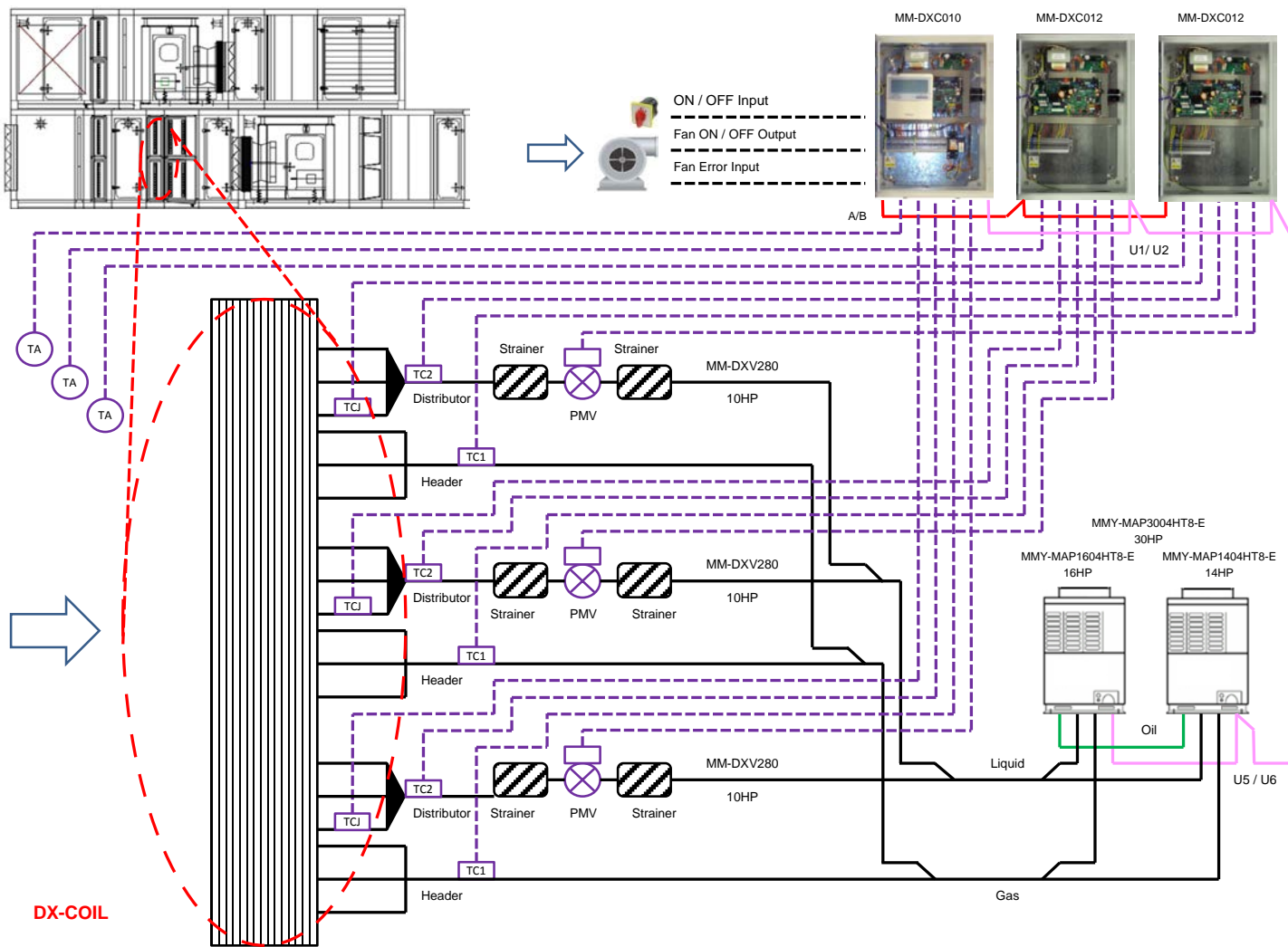

Where installed in a Group the MM-DXC010 DX Coil Controller has to be configured on site by the installer. The MM-DXC012 DX Coil Controllers are configured at the factory. Each Controller is linked using U1 / U2 and A / B.

All input / output options are connected to the MM-DXC010 DX Coil Controller which also contains a RBC-AMT32E Remote Controller.

Each DX Coil Controller uses a DX valve kit (MM-DXV080/140/280), the PMV and sensors leads need to be carefully connected to correct controller.

2 SUPPLIED PARTS

The VRF DX Coil Interface is designed to allow the connection of a customer's air handling unit (with R410A DX Coil) to a Toshiba VRF outdoor unit (MiNi-SMMS / MiNi-SMMSe / SMMS / SMMSi / SMMSe / SHRM / SHRMi / SHRMe).

The Interface consists of a DX Coil Controller, and a DX Coil Valve Kit (3 sizes). This is a kit of parts which the installer needs to assemble (including brazing).



MM-DXC010	DX Coil Controller (Individual / Header)
MM-DXC012	DX Coil Controller (Follower)
MM-DXV080	DX Coil Valve Kit (5.6kW, 7.1kW, 8.0kW)
MM-DXV140	DX Coil Valve Kit (11.2kW, 14.0kW, 16.0kW)
MM-DXV280	DX Coil Valve Kit (22.4kW, 28.0kW)

DX Coil Valve Kit contents:-

Item	Description	Qty
	TA Sensor (Resin)	1
	TC1 Sensor (Ø4)	1
	TC2 Sensor (Ø6)	1
	TCJ Sensor (Ø6)	1

Item	Description	Qty
	PMV	1
	Sensor Holder (Ø4)	1
	Sensor Holder (Ø6)	2
	Fix Plate (Ø4)	1

Item	Description	Qty
	Fix Plate (Ø6)	2
	Strainer	2
	P Clamp (TA)	1

3 PRECAUTIONS FOR SAFETY

- Ensure that all Local, National and International regulations are satisfied.
- Read this "PRECAUTIONS FOR SAFETY" carefully before installation.
- The precautions described below include the important items regarding safety. Observe them without fail.
- After the installation work, perform a trial operation to check for any problem.
- Follow the Owner's Manual to explain how to use and maintain the unit to the customer.
- Turn off the main power supply switch (or breaker) before the unit maintenance.
- Ask the customer to keep the installation manual.

CAUTION

New Refrigerant Air Conditioner Installation

- **THIS AIR CONDITIONER ADOPTS THE NEW HFC REFRIGERANT (R410A) WHICH DOES NOT DESTROY OZONE LAYER.**

The characteristics of R410A refrigerant are; easy to absorb water, oxidizing membrane or oil, and its pressure is approx. 1.6 times higher than that of refrigerant R22. Accompanied with the new refrigerant, refrigerating oil has also been changed. Therefore, during installation work, be sure that water, dust, former refrigerant, or refrigerating oil does not enter the refrigerating cycle.

To prevent charging an incorrect refrigerant and refrigerating oil, the sizes of connecting sections of charging port of the main unit and installation tools are changed from those of conventional refrigerant.

Accordingly the exclusive tools are required for the new refrigerant (R410A).

For connecting pipes, use new and clean piping designed for R410A, and please care so that water or dust does not enter. Moreover, do not use the existing piping because there are problems with the pressure-resistance force and impurity in it.

CAUTION

To Disconnect the Appliance from Main Power Supply

This appliance must be connected to the main power supply by means of a switch with a constant separation of at least 3mm.

4 INSTALLATION

For DX-Coils (>10HP) Y-branching MUST be used to ensure even refrigerant distribution between pathways (Header branching cannot be used with the DX-Interface).

Use the following tables to determine the appropriate VRF DX Interface components based on the required AHU capacity:-

2.0 - 10.0HP Individual	All VRF	2.0	2.5	3.0	4.0	5.0	6.0	8.0	10.0
MM-DXC010	-	1	1	1	1	1	1	1	1
MM-DXC012	-								
MM-DXV080	2.0	1							
MM-DXV080	2.5		1						
MM-DXV080	3.0			1					
MM-DXV140	4.0				1				
MM-DXV140	5.0					1			
MM-DXV140	6.0						1		
MM-DXV280	8.0							1	
MM-DXV280	10.0								1
Nominal Capacity (kW)	Cool ^{*1}	5.6	7.1	8.0	11.2	14.0	16.0	22.4	28.0
	Heat ^{*2}	6.3	8.0	9.0	12.5	16.0	18.0	25.0	31.5
DX Coil Internal Volume (cc)	Min	850	1063	1275	1700	2125	2550	3400	4250
	Std	1000	1250	1500	2000	2500	3000	4000	5000
	Max	1150	1438	1725	2300	2875	3450	4600	5750
Recommended Liquid Orifice	Ø mm	3.2 ~ 3.5	3.4 ~ 3.8	3.5 ~ 4.0	4.5 ~ 5.0	5.0 ~ 5.6	5.5 ~ 6.0	6.5 ~ 7.0	7.0 ~ 8.0
Gas Pipe	Ø mm	12.7	15.9	15.9	15.9	15.9	15.9	19.1	22.2
Liquid Pipe	Ø mm	6.4	9.5	9.5	9.5	9.5	9.5	12.7	12.7
Standard Air volume flow rate ^{*5}	m ³ /hr	900	1125	1320	1600	2100	2800	3600	4200

12.0 - 30.0HP Group	SMMSi	12.0	14.0	16.0	18.0	20.0	22.0	24.0	26.0	28.0	30.0
MM-DXC010	-	1	1	1	1	1	1	1	1	1	1
MM-DXC012	-	1	1	1	1	1	2	2	2	2	2
MM-DXV140	6.0	2	1				1				
MM-DXV280	8.0		1	2	1		2	3	2	1	
MM-DXV280	10.0				1	2			1	2	3
Nominal Capacity (kW)	Cool ^{*1}	32.0	38.4	44.8	50.4	56.0	60.8	67.2	72.8	78.4	84.0
	Heat ^{*2}	36.0	43.0	50.0	56.5	63.0	68.0	75.0	81.5	88.0	94.5
DX Coil Internal Volume (cc)	Min	5100	5950	6800	7650	8500	9350	10200	11050	11900	12750
	Std	6000	7000	8000	9000	10000	11000	12000	13000	14000	15000
	Max	6900	8050	9200	10350	11500	12650	13800	14950	16100	17250
Recommended Liquid Orifice	mm	*3	*3	*3	*3	*3	*3	*3	*3	*3	*3
Gas Pipe	Ø mm	*3	*3	*3	*3	*3	*3	*3	*3	*3	*3
Liquid Pipe	Ø mm	*3	*3	*3	*3	*3	*3	*3	*3	*3	*3
Standard Air volume flow rate ^{*5}	m ³ /hr	5600	6400	7200	7800	8400	10000	10800	11400	12000	12600

32.0 - 48.0HP Group	SMMSi	32.0	34.0	36.0	38.0	40.0	42.0	44.0	46.0	48.0
MM-DXC010	-	1	1	1	1	1	1	1	1	1
MM-DXC012	-	3	3	3	3	3	4	4	4	4
MM-DXV140	6.0									
MM-DXV280	8.0	4	3	2	1		4	3	2	1
MM-DXV280	10.0		1	2	3	4	1	2	3	4
Nominal Capacity (kW)	Cool ^{*1}	89.6	95.4	100.8	106.4	112.0	117.6	123.2	128.8	134.5
	Heat ^{*2}	100.0	106.5	113.0	119.5	126.0	131.5	138.0	144.5	151.0
DX Coil Internal Volume (cc)	Min	13600	14450	15300	16150	17000	17850	18700	19550	20400
	Std	16000	17000	18000	19000	20000	21000	22000	23000	24000
	Max	18400	19550	20700	21850	23000	24150	25300	26450	27600
Recommended Liquid Orifice	mm	*3	*3	*3	*3	*3	*3	*3	*3	*3
Gas Pipe	Ø mm	*3	*3	*3	*3	*3	*3	*3	*3	*3
Liquid Pipe	Ø mm	*3	*3	*3	*3	*3	*3	*3	*3	*3
Standard Air volume flow rate ^{*5}	m ³ /hr	14400	15000	15600	16200	16800	18600	19200	19800	20400

12.0 - 28.0HP Group	SMMSe	12.0	14.0	16.0	18.0	20.0	22.0	24.0	26.0	28.0
MM-DXC010	-	1	1	1	1	1	1	1	1	1
MM-DXC012	-	1	1	1	1	1	2	2	2	2
MM-DXV140	6.0	2	1				1			
MM-DXV280	8.0		1	2	1		2	3	2	1
MM-DXV280	10.0				1	2			1	2
Nominal Capacity (kW)	Cool ^{*1}	33.5	40.0	45.0	50.4	56.0	61.5	67.0	73.5	78.5
	Heat ^{*2}	37.5	45.0	50.0	56.0	63.0	64.0	75.0	82.5	87.5
DX Coil Internal Volume (cc)	Min	5100	5950	6800	7650	8500	9350	10200	11050	11900
	Std	6000	7000	8000	9000	10000	11000	12000	13000	14000
	Max	6900	8050	9200	10350	11500	12650	13800	14950	16100
Recommended Liquid Orifice	mm	*3	*3	*3	*3	*3	*3	*3	*3	*3
Gas Pipe	Ø mm	*3	*3	*3	*3	*3	*3	*3	*3	*3
Liquid Pipe	Ø mm	*3	*3	*3	*3	*3	*3	*3	*3	*3
Standard Air volume flow rate ^{*5}	m ³ /hr	5600	6400	7200	7800	8400	10000	10800	11400	12000

30.0 - 46.0HP Group	SMMSe	30.0	32.0	34.0	36.0	38.0	40.0	42.0	44.0	46.0
MM-DXC010	-	1	1	1	1	1	1	1	1	1
MM-DXC012	-	2	3	3	3	3	3	4	4	4
MM-DXV140	6.0									
MM-DXV280	8.0		4	3	2	1		4	3	2
MM-DXV280	10.0	3		1	2	3	4	1	2	3
Nominal Capacity (kW)	Cool ^{*1}	85.0	90.0	95.4	101.0	106.5	112.0	117.5	123.0	130.0
	Heat ^{*2}	95.0	100.0	106.5	113.0	114.0	126.0	127.0	128.0	145.0
DX Coil Internal Volume (cc)	Min	12750	13600	14450	15300	16150	17000	17850	18700	19550
	Std	15000	16000	17000	18000	19000	20000	21000	22000	23000
	Max	17250	18400	19550	20700	21850	23000	24150	25300	26450
Recommended Liquid Orifice	mm	*3	*3	*3	*3	*3	*3	*3	*3	*3
Gas Pipe	Ø mm	*3	*3	*3	*3	*3	*3	*3	*3	*3
Liquid Pipe	Ø mm	*3	*3	*3	*3	*3	*3	*3	*3	*3
Standard Air volume flow rate ^{*5}	m ³ /hr	12600	14400	15000	15600	16200	16800	18600	19200	19800

48.0 - 60.0HP Group	SMMSe	48.0	50.0	52.0	54.0	56.0	58.0	60.0
MM-DXC010	-	1	1	1	1	1	1	1
MM-DXC012	-	4	4	5	5	5	5	5
MM-DXV140	6.0							
MM-DXV280	8.0	1		4	3	2	1	
MM-DXV280	10.0	4	5	2	3	4	5	6
Nominal Capacity (kW)	Cool ^{*1}	135.0	140.4	146.0	151.5	157.0	162.5	168.0
	Heat ^{*2}	150.0	156.0	163.0	164.0	176.0	177.0	178.0
DX Coil Internal Volume (cc)	Min	20400	21250	22100	22950	23800	24650	25500
	Std	24000	25000	26000	27000	28000	29000	30000
	Max	27600	28750	29900	31050	32200	33350	34500
Recommended Liquid Orifice	mm	*3	*3	*3	*3	*3	*3	*3
Gas Pipe	Ø mm	*3	*3	*3	*3	*3	*3	*3
Liquid Pipe	Ø mm	*3	*3	*3	*3	*3	*3	*3
Standard Air volume flow rate ^{*5}	m ³ /hr	20400	21000	22800	23400	24000	24600	25200

12.0 - 26.0HP Group	SHRMi	12.0	14.0	16.0	18.0	20.0	22.0	24.0	26.0
MM-DXC010	-	1	1	1	1	1	1	1	1
MM-DXC012	-	1	1	1	1	1	2	2	2
MM-DXV140	6.0	2	1				1		
MM-DXV280	8.0		1	2	1		2	3	2
MM-DXV280	10.0				1	2			1
Capacity ^{*2} (kW)	Cool ^{*1}	33.5	40.0	45.0	50.4	56.0	61.5	68.0	73.5
	Heat ^{*2}	37.5	45.0	50.0	56.5	63.0	69.0	76.5	81.5
DX Coil Internal Volume (cc)	Min	5100	5950	6800	7650	8500	9350	10200	11050
	Std	6000	7000	8000	9000	10000	11000	12000	13000
	Max	6900	8050	9200	10350	11500	12650	13800	14950
Recommended Liquid Orifice	mm	*3	*3	*3	*3	*3	*3	*3	*3
Gas Pipe	Ø mm	*3	*3	*3	*3	*3	*3	*3	*3
Liquid Pipe	Ø mm	*3	*3	*3	*3	*3	*3	*3	*3
Standard Air volume flow rate ^{*5}	m ³ /hr	5600	6400	7200	7800	8400	10000	10800	11400

28.0 - 42.0HP Group	SHRMi	28.0	30.0	32.0	34.0	36.0	38.0	40.0	42.0
MM-DXC010	-	1	1	1	1	1	1	1	1
MM-DXC012	-	2	2	3	3	3	3	3	4
MM-DXV140	6.0								
MM-DXV280	8.0	1		4	3	2	1		4
MM-DXV280	10.0	2	3		1	2	3	4	1
Capacity ^{*2} (kW)	Cool ^{*1}	78.5	85.0	90.0	96.0	101.0	106.5	112.0	118.0
	Heat ^{*2}	88.0	95.0	100.0	108.0	113.0	119.5	127.0	132.0
DX Coil Internal Volume (cc)	Min	11900	12750	13600	14450	15300	16150	17000	17850
	Std	14000	15000	16000	17000	18000	19000	20000	21000
	Max	16100	17250	18400	19550	20700	21850	23000	24150
Recommended Liquid Orifice	mm	*3	*3	*3	*3	*3	*3	*3	*3
Gas Pipe	Ø mm	*3	*3	*3	*3	*3	*3	*3	*3
Liquid Pipe	Ø mm	*3	*3	*3	*3	*3	*3	*3	*3
Standard Air volume flow rate ^{*5}	m ³ /hr	12000	12600	14400	15000	15600	16200	16800	18600

12.0 - 26.0HP Group	SHRMe ^{*6}	12.0	14.0	16.0	18.0	20.0	22.0	24.0	26.0
MM-DXC010	-	1	1	1	1	1	1	1	1
MM-DXC012	-	1	1	1	1	1	2	2	2
MM-DXV140	6.0	2	1				1		
MM-DXV280	8.0		1	2	1		2	3	2
MM-DXV280	10.0				1	2			1
Capacity ^{*2} (kW)	Cool ^{*1}	33.5	40.0	45.0	50.4	56.0	61.5	68.0	73.5
	Heat ^{*2}	37.5	45.0	50.0	56.5	58.0	69.0	76.5	82.5
DX Coil Internal Volume (cc)	Min	5100	5950	6800	7650	8500	9350	10200	11050
	Std	6000	7000	8000	9000	10000	11000	12000	13000
	Max	6900	8050	9200	10350	11500	12650	13800	14950
Recommended Liquid Orifice	mm	*3	*3	*3	*3	*3	*3	*3	*3
Gas Pipe	Ø mm	*3	*3	*3	*3	*3	*3	*3	*3
Liquid Pipe	Ø mm	*3	*3	*3	*3	*3	*3	*3	*3
Standard Air volume flow rate ^{*5}	m ³ /hr	5600	6400	7200	7800	8400	10000	10800	11400

28.0 - 42.0HP Group	SHRMe ^{*6}	28.0	30.0	32.0	34.0	36.0	38.0	40.0	42.0
MM-DXC010	-	1	1	1	1	1	1	1	1
MM-DXC012	-	2	2	3	3	3	3	3	4
MM-DXV140	6.0								
MM-DXV280	8.0	1		4	3	2	1		4
MM-DXV280	10.0	2	3		1	2	3	4	1
Capacity ^{*4} (kW)	Cool ^{*1}	80.0	85.0	90.4	95.4	100.8	106.4	112.0	120.0
	Heat ^{*2}	90.0	95.0	101.5	106.5	113.0	114.5	126.0	135.0
DX Coil Internal Volume (cc)	Min	11900	12750	13600	14450	15300	16150	17000	17850
	Std	14000	15000	16000	17000	18000	19000	20000	21000
	Max	16100	17250	18400	19550	20700	21850	23000	24150
Recommended Liquid Orifice	mm	*3	*3	*3	*3	*3	*3	*3	*3
Gas Pipe	Ø mm	*3	*3	*3	*3	*3	*3	*3	*3
Liquid Pipe	Ø mm	*3	*3	*3	*3	*3	*3	*3	*3
Standard Air volume flow rate ^{*5}	m ³ /hr	12000	12600	14400	15000	15600	16200	16800	18600

^{*1} Cooling Capacity Conditions (Indoor 27 °Cdb / 19 °Cwb & Outdoor 35 °Cdb) at Standard Air Flow rate

^{*2} Heating Capacity Conditions (Indoor 20 °Cdb & Outdoor 7 °Cdb / 6 °Cdb) at Standard Air Flow rate

^{*3} DX-Coils > 10Hp must be designed with multiple pathways each 10HP or less. These pathways must have dedicated Headers and Liquid Capillary distributors. Therefore recommended sizes only needed for 2 - 10HP.

^{*4} SHRMe Capacity quoted as nominal cooling and maximum heating.

^{*5} The standard Air volume flow rate is a guideline. The required capacity should determine DX-Interface size selection.

^{*6} Single Port Flow Selectors (3-Series) MUST be used with the DX-Interface. It is not compatible with Multi Port Flow Selector (This limits the maximum SHRMe DX-Interface size to 42HP).

Heating & Cooling Capacity are guideline figures, the design of each customer's AHU and DX Coil will have an impact on the actual system performance.

Toshiba Carrier (UK) Ltd does not take any responsibility on the local design of the DX coil.

NOTES

Design Conditions for customers DX Coil

- The DX-Coil **MUST** be operated within the following limits to ensure reliability:-
 - Cooling mode DX coil “air on” temp: Min: 15°CWB (18°CDB) ~ Max: 24°CWB (32°CDB)
 - Heating mode DX coil “air on” temp: Min: 15°CDB ~ Max: 28°CDB
- When used for Ventilation, the DX-Coil **MUST** be combined with other equipment such as heat recovery exchanger or heaters / coolers to ensure that the CA limits are not exceeded:-

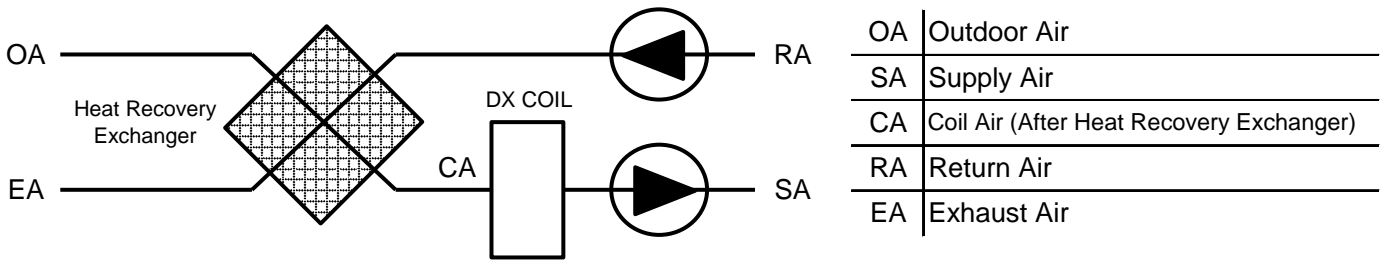

DX-Coil Design

- The DX Coil must be suitable for R410A.
- The design should allow operation as both an Evaporator and a Condenser (Features: Multiple circuits / Liquid Capillary Distributor / Gas Header).
- The counter flow principle must be observed.
- Design target Evaporation temperature: 6.5°C.
- Design target Condensation temperature: 52°C.
- A Drain Pan must be fitted (even if only used in Heat mode) due to defrost cycles.
- It is recommended to fit droplet eliminator plates in the discharge air stream if used in Cool mode.
- The sensor holders must be brazed on to DX coil to ensure accurate temperature sensing.
- DX Coils (>10HP) must be designed with multiple pathways each 10HP or less. These pathways must have dedicated Headers and Liquid Capillary Distributors each with the appropriate DX Valve Kit. These DX-Coils can be Interlaced or Split face:-



DX-Coil Style	Normal	Interlaced	Split face
DX-Coil Image			
Pathway	<ul style="list-style-type: none"> • 1 Pathway • 2 – 10 HP 	<ul style="list-style-type: none"> • 2 Pathways or more • Pathways are parallel • > 10 HP 	<ul style="list-style-type: none"> • 2 Pathways or more • Pathways are stacked • > 10 HP

- Where Grouped the Header Controller (MM-DXC010) must be connected to the largest DX Coil Valve Kit.
- AHU fan motor must be interlocked to fan control output.
- Maximum DX-Coil U-pipe Outer Diameter: 12.7mm (1/2")
- Recommended DX-Coil U-pipe Outer Diameter: 9.52mm (3/8")

Recommended No. of Circuits v U-Pipe Diameter

U-Pipe Diameter	HP	Nominal Capacity (kW)		No. of Circuits	
		Cool	Heat	Min	Max
8.0	2.0	5.6	6.3	3	4
	2.5	7.1	8.0	3	4
	3.0	8.0	9.0	4	6
	4.0	11.2	12.5	5	8
	5.0	14.0	16.0	6	8
	6.0	16.0	18.0	6	10
	8.0	22.4	25.0	8	12
	10.0	28.0	31.5	10	14
9.52	2.0	5.6	6.3	2	3
	2.5	7.1	8.0	2	3
	3.0	8.0	9.0	3	4
	4.0	11.2	12.5	3	5
	5.0	14.0	16.0	4	6
	6.0	16.0	18.0	5	7
	8.0	22.4	25.0	6	10
	10.0	28.0	31.5	8	12
12.7	2.0	5.6	6.3	2	2
	2.5	7.1	8.0	2	2
	3.0	8.0	9.0	2	2
	4.0	11.2	12.5	2	3
	5.0	14.0	16.0	3	3
	6.0	16.0	18.0	3	4
	8.0	22.4	25.0	4	6
	10.0	28.0	31.5	5	7

Diversity Ratio (When a DX Coil Interface is connected)

- MiNi-SMMS: 100% to 100%
- SMMS / SMMSi / SMMS_e: 60% to 110%
- SHRM / SHRMi: 60% to 110%
- SHRMe: 70% to 110%

Automatic Mode

- Please be aware that frequent mode changes could occur when using Automatic mode (SHRM / SHRMi / SHRMe).

IP65

- If the wiring is properly carried out by a specialist according to the local regulations, the device fulfils the protection class IP65.

DX COIL CONTROLLER (MM-DXC010)

The DX Coil Controller MUST NOT be installed outside. To maintain waterproof integrity IP65 glands must be used through the gland plate (To avoid damage; when making holes for cables glands, please first remove the Gland Plate from the DX Coil Controller).

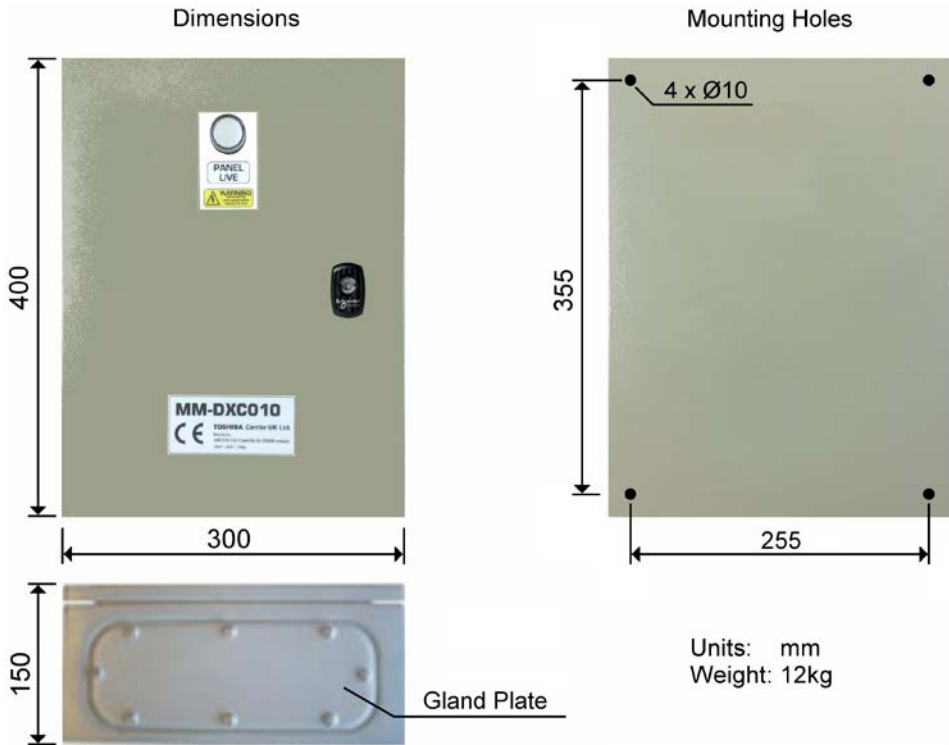

Note: In areas where there is a risk of dew condensation insulation (locally sourced) should be fitted to the DX controller enclosure

PIPING SCHEMATIC (INDIVIDUAL)

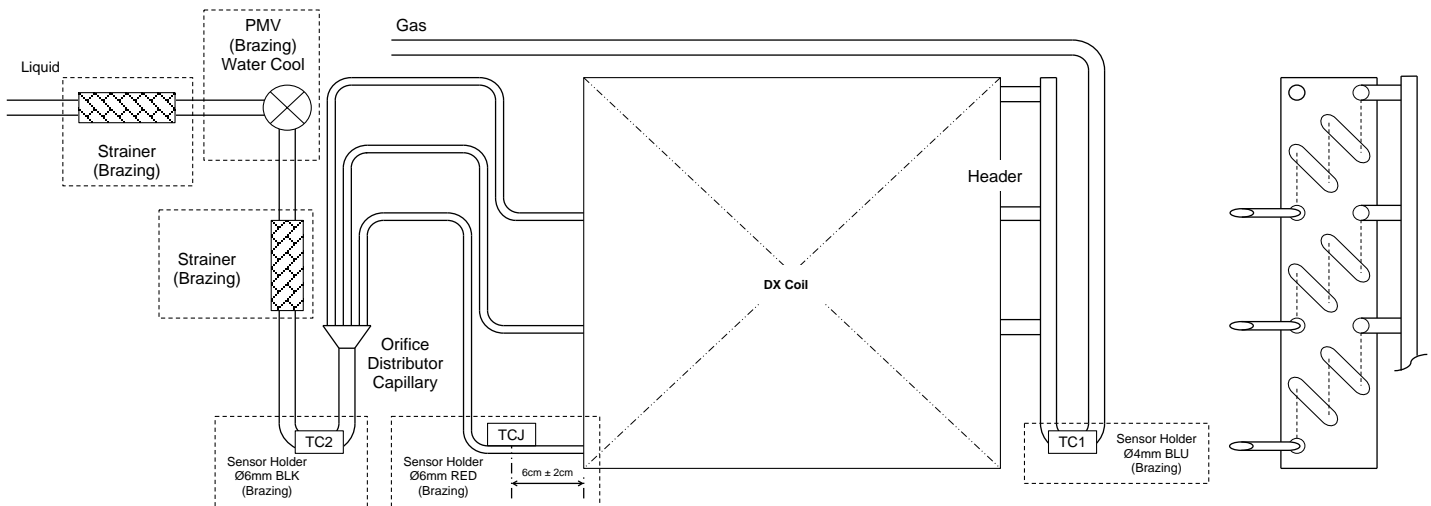

Notes:

- 1) The PMV must be water cooled whilst brazing, to prevent damage to the mechanism.
- 2) To ensure reliable operation, all Sensor Holders must be fitted by brazing.
- 3) The TCJ Sensor Holder must be brazed to the capillary on the DX Coil's lowest circuit.
- 4) For brazing, be sure to use nitrogen gas to avoid oxidation of pipe inner surface.

■ DX COIL CONTROLLER (MM-DXC012)

The DX Coil Controller MUST NOT be installed outside. To maintain waterproof integrity IP65 glands must be used through the gland plate (To avoid damage; when making holes for cables glands, please first remove the Gland Plate from the DX Coil Controller).

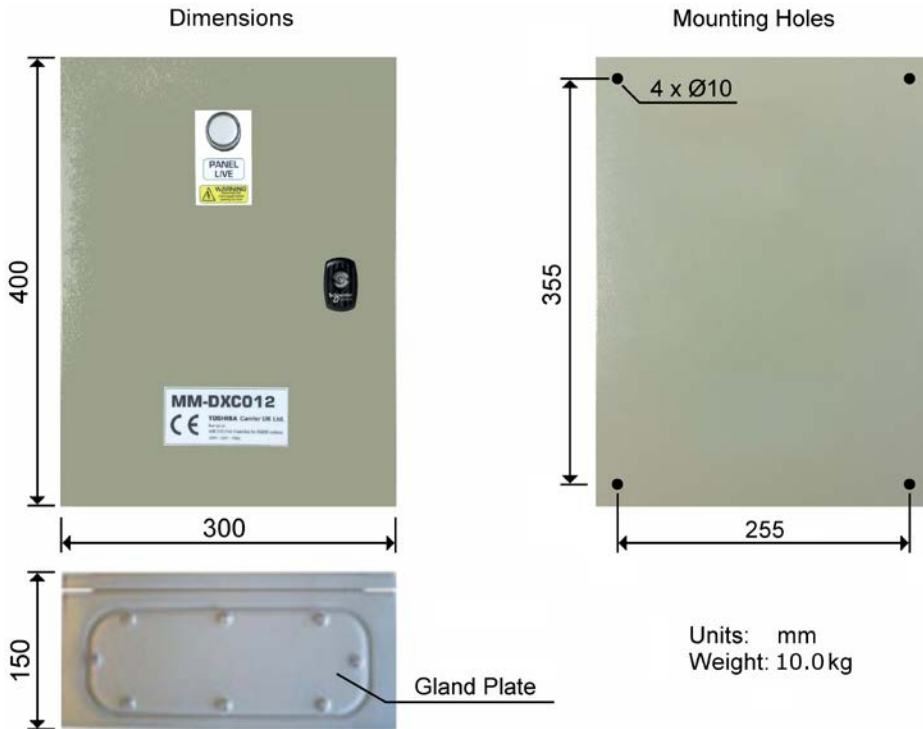

Note: In areas where there is a risk of dew condensation insulation (locally sourced) should be fitted to the DX controller enclosure

■ PIPING SCHEMATIC (GROUP)

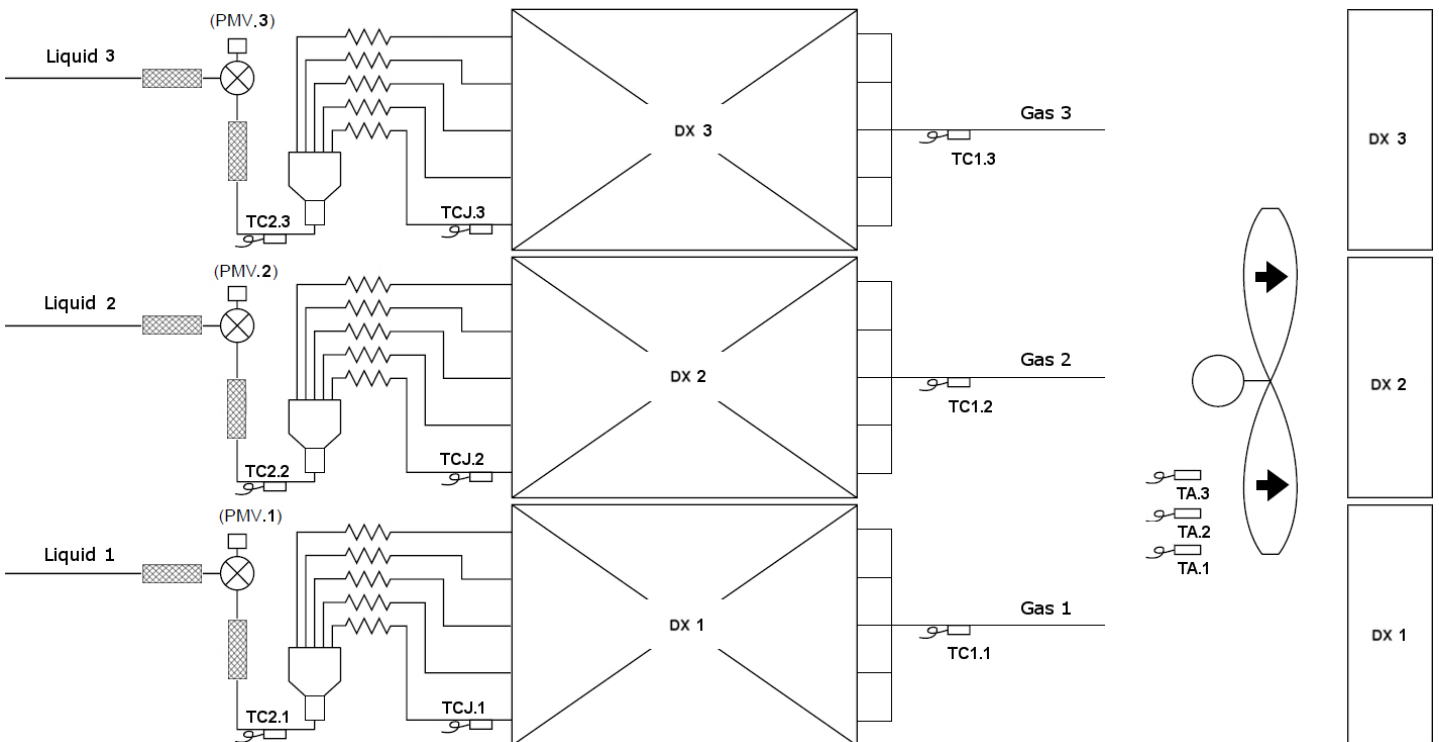

Notes:

- 1) The PMV must be water cooled whilst brazing, to prevent damage to the mechanism.
- 2) To ensure reliable operation, all Sensor Holders must be fitted by brazing.
- 3) The TCJ Sensor Holder must be brazed to the capillary on the DX Coil's lowest circuit.
- 4) For brazing, be sure to use nitrogen gas to avoid oxidation of pipe inner surface.
- 5) The Header DX Coil must be the lowest section ("DX 1" in this example).

DX COIL PREPARATION

The DX Coil Valve Kit is supplied as separate components. These will need to be assembled and then fitted to DX Coil. This is a custom process as each DX Coil will be different, time and care should be given to this activity, and it should be prepared off-site. Note that the PMV body **MUST** be water cooled whilst brazing. For brazing, be sure to use nitrogen gas to avoid oxidation of pipe inner surface.

Typically the 3rd Party DX Coil will be supplied with a Gas Header and Liquid Capillary Distributor (see below):-

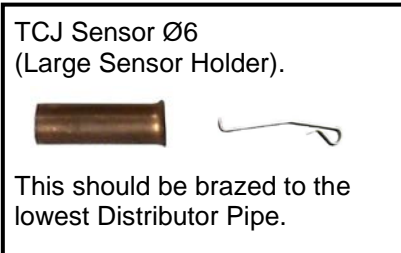

Avoid positioning Sensor holders in the Drain Pan where they could be immersed in water.

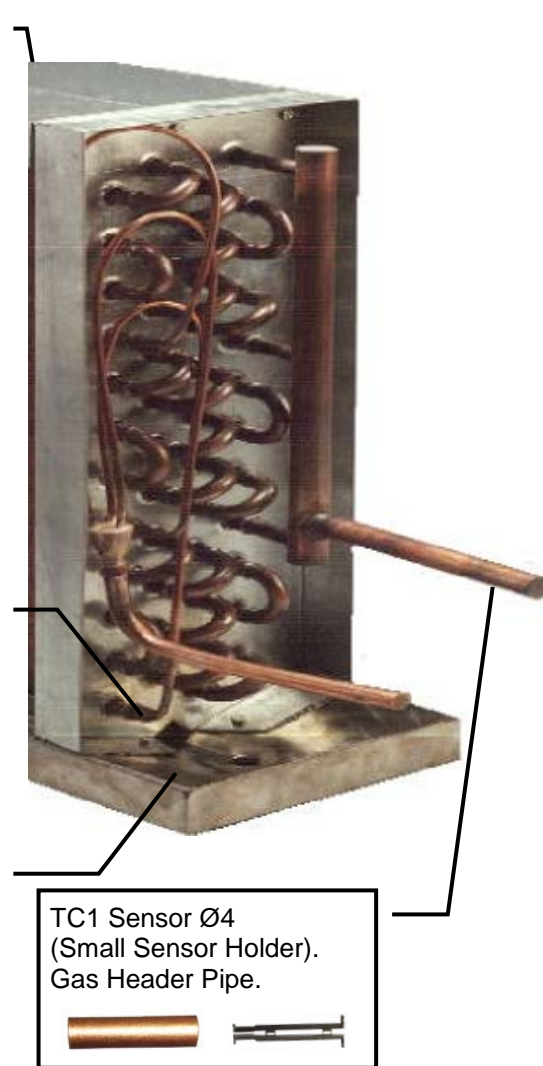

SENSOR HOLDERS

Sensor Holders **MUST** be brazed on to the DX Coil pipe work to ensure reliable temperature sensing. There are three coil sensors, these are inserted into the Sensor Holders, and secured with the sensor-fix-plate. The sensor holders should be brazed at the 6 o'clock position (see Right hand image). It is essential that the sensors are correctly located to ensure efficient system performance.

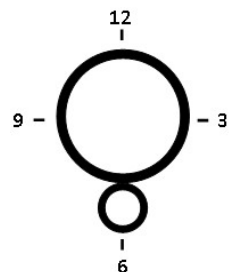

TA SENSOR



Secure this sensor using the supplied plastic clamp. It must be located in the Return Air Flow (Prior to mixing with any fresh air). Ensure that the Resin Sensor bulb is not covered by the protective vinyl-tube. When Grouped the TA sensors must be positioned together (see Right hand image).



DX COIL VALVE KIT

The supplied components need to be assembled on to the DX Coil locally. Note the PMV MUST be water cooled whilst brazing.

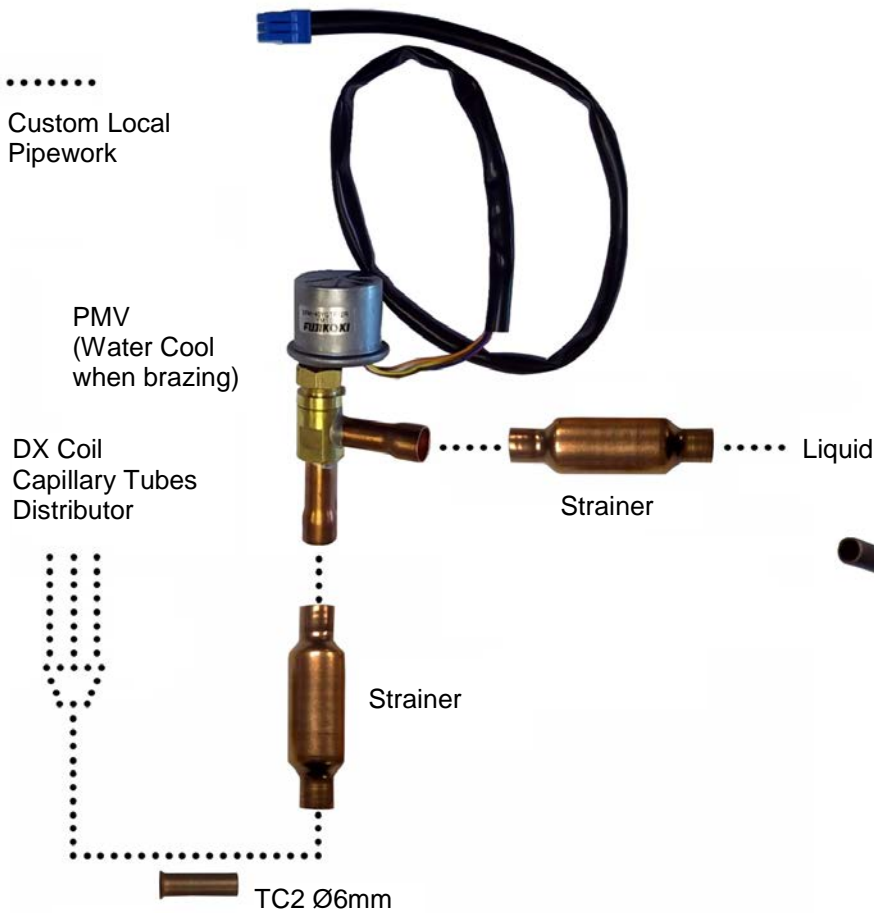

The PMV must be installed upright (as shown).

The flow through the PMV can be in either direction, however the TC2 sensor must be fitted on the distributor side.

The PMV and Strainer have an internal diameter of 12.8mm.

Example



NOTES

1. The connection angle between PMV body and PMV head is fixed at the factory (using thread lock) and should not be changed.
2. The PMV head should not be removed from PMV body.
3. Carefully handle and prepare the PMV when fitting to prevent ingress from foreign matter such as dust or water.
4. Cautions when Brazing PMV
 - A) Whilst brazing, the PMV body and PMV head must be water cooled to keep the component's temperature below 100°C.
 - B) Whilst brazing, nitrogen gas must be flowed through the PMV valve and pipework to prevent internal oxidization.
 - C) Prevent cooling water from getting inside the PMV valve and connector of the lead during brazing.
 - D) Take care not to damage the PMV cables during brazing.

5 ELECTRICAL WORK

WARNING

1. **Using the specified wires, ensure to connect the wires, and fix wires securely so that the external tension to the wires do not affect the connecting part of the terminals.**
Incomplete connection or fixation may cause a fire, etc.
2. **Be sure to connect earth wire (grounding work).**
Incomplete grounding cause an electric shock. Do not connect ground wires to gas pipes, water pipes, lightning rods or ground wires for telephone wires.
3. **Appliance shall be installed in accordance with national wiring regulations.**
Capacity shortage of power circuit or incomplete installation may cause an electric shock or a fire.

CAUTION

- If incorrect / incomplete wiring is carried out, it will cause an electrical fire or smoke.
- Be sure to install an earth leakage breaker that is not tripped by shock waves.
If an earth leakage breaker is not installed, an electric shock may be caused.
- Be sure to use the cord clamps attached to the product.
- Do not damage or scratch the conductive core and inner insulator of power and inter-connecting wires when peeling them.
- Use the power cord and inter-connecting wire of specified thickness, type and protective devices required
- Never connect 220-240V power to the terminal blocks (U, V, A, B, etc) for control wiring (otherwise the system will fail).

REQUIREMENT

- For power supply wiring, strictly conform to the Local Regulation for each country.
- For wiring of power supply of the outdoor units, follow the Installation manual of each outdoor unit.
- Perform the electric wiring so that it does not come in to contact with the high-temperature part of the pipe.
The coating may melt in an accident
- After connecting wires to the terminal blocks, provide a trap and fix the wires with the cord clamp.
- Run the refrigerant piping and control wiring line in the same line.
- Do not turn on the power of the indoor unit until vacuuming of the refrigerant pipes completes.

■ Power supply wire and communication wires specifications

Power supply wire and communication wires are procured locally.
For the power supply specifications, follow to the table below. If capacity is little, it is dangerous because overheat or seizure may be caused. For specifications of the power capacity of the outdoor unit and the power supply wires, refer to the Installation manual attached to the outdoor unit.

Cable size must be calculated for site condition and correct glands fitted. All cables should be in conduit or armoured cables correctly glanded. This has to be done by the site installer.

Indoor unit power supply

- For the power supply of the indoor unit, prepare the exclusive power supply separated from that of the outdoor unit.
- Arrange the power supply, earth leakage breaker and main switch of the indoor unit connected to the same outdoor unit so that they are commonly used.
- Power supply wire specification: Cable 3-Core 2.5mm², **in conformity with Design 60245 IEC 57.**

▼ Power supply.

Power supply	220~240V ~ 50Hz	
Power supply switch / Earth leakage breaker or power supply wirings / fuse rating for indoor units should be selected by the accumulated total current values of the indoor units.		
Power supply wiring	Below 50m	2.5mm ²

Control wiring, Central controller wiring

- 2-core with polarity wires are used for the Control wiring between indoor and outdoor unit and Central controller wiring.
- To prevent noise trouble, use 2-core shield wire.
- The length of the communication line means the total length of the inter-unit wire length between indoor and outdoor units added with the central control system wire length.

▼ **Communication Line**

Control wiring between indoor units and outdoor unit (2-core shield wire)	Wire Size	(Up to 1000m) ≥ 1.5mm ² (Up to 2000m) ≥ 2.5mm ²
Central control line wiring (2-core shield wire)	Wire Size	(Up to 1000m) ≥ 1.5mm ² (Up to 2000m) ≥ 2.5mm ²

Remote controller wiring

- 2-core with non-polarity wire is used for wiring of the remote controller wiring and group remote controllers wiring.

Remote controller wiring. Remote controller inter-unit wiring	Wire size: 0.75mm ² to 2.5mm ²
---	--

Total wire length of remote controller wiring and remote controller inter-unit wiring = L + L1 + L2 +Ln	In case of wired type only	Up to 500m
	In case of wireless type included	Up to 400m
Total wire length of remote controller inter-unit wiring = L1 + L2 +Ln		Up to 200m

⚠ CAUTION

The remote controller wire (communication line) and AC220-240V wires cannot be parallel to contact each other and cannot be stored in the same conduits. If doing so, a trouble may be caused on the control system due to noise, etc.

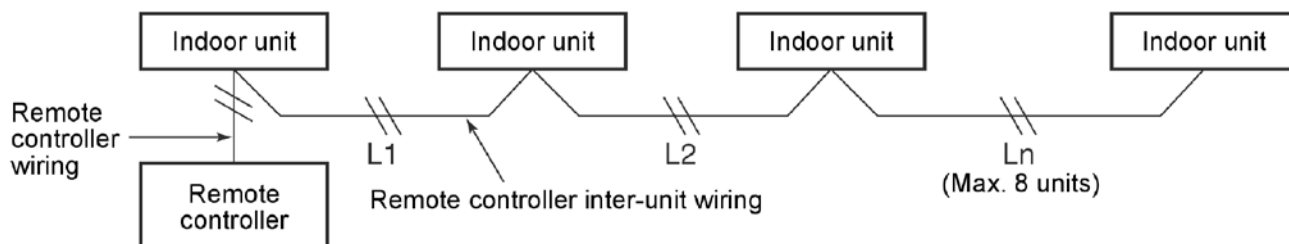

■ **Remote controller wiring**

- As the remote controller wire has non-polarity, there is no problem if connections to indoor unit terminal blocks A and B are reversed.

▼ **Wiring diagram**

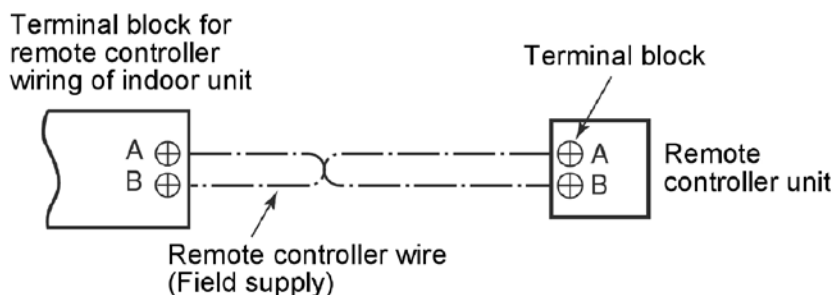

■ Wiring between indoor and outdoor units

NOTE

An outdoor unit connected with control wiring between indoor and outdoor units wire becomes automatically the header unit.

▼ Wiring example

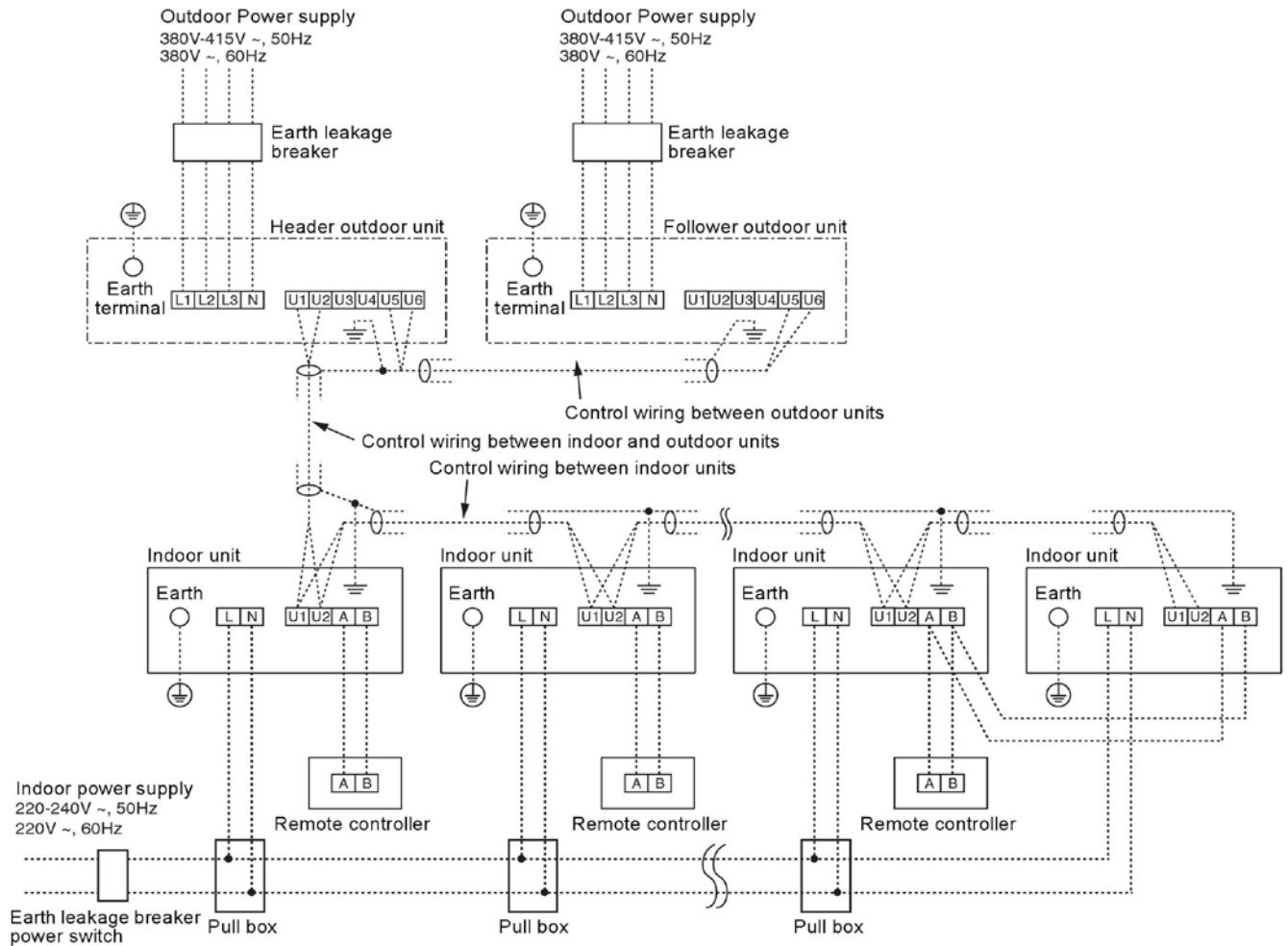

■ Group Control (Header / Follower wiring)

The AB terminals between the Header and Follower controllers must be connected together.

Further DN Code setup must be completed:-

<u>MM-DXC010</u>	<u>DX Controller (Header)</u>
DN 0E_0001	Group Control (set by installer)
DN 14_0001	Header (set by installer)

<u>MM-DXC012</u>	<u>DX Controller (Follower)</u>
DN 0E_0001	Group Control (set at factory)
DN 14_0002	Follower (set at factory)

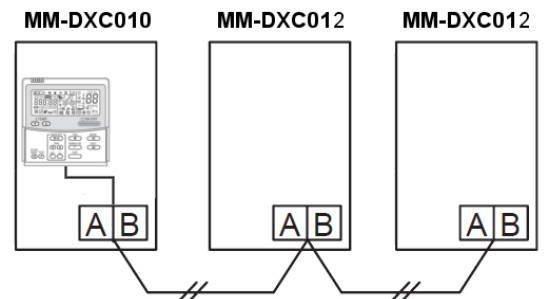

■ Address setup

Set up the addresses as per the Installation manual supplied with the outdoor unit.

■ ELECTRICAL CONNECTIONS (MM-DXC010)

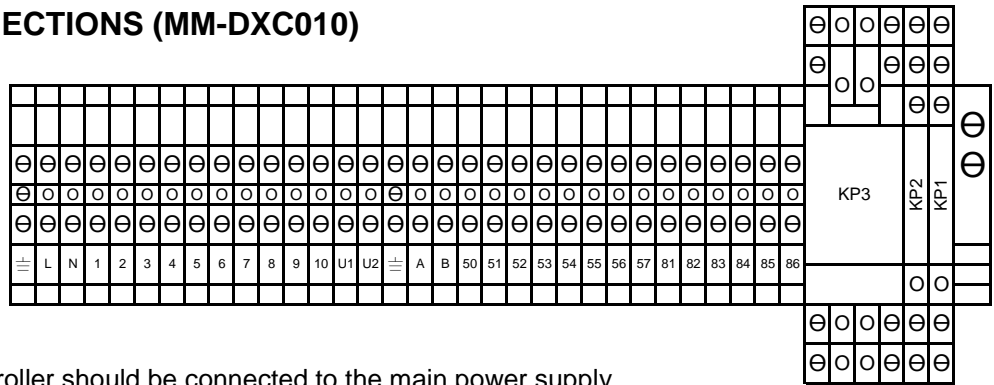

Supply

Terminal \ominus / L / N The controller should be connected to the main power supply by means of a switch with a contact separation of at least 3mm.

External On / Off (optional)

Terminal 1 / 2 On/off over an external dry contact. If the contact is closed, the system switches on. If the contact is opened, the system switches off. If the system is switched using an external contact, then switching on/off using the remote control is still possible.

Fan Error input (optional)

Terminal 3 / 4 An AHU fan operation monitor (supplied locally), could be attached at this dry contact terminal (for instance, differential pressure monitor, vane relay or similar). A closed contact generates the error message L30 (Rating 12VDC).

Alarm signal from the DX-Interface (optional)

Terminal 5 / 6 If there is an error at the DX-Interface, this is indicated with a dry normally open contact at this terminal (Contact Rating 250VAC 8A).

Fan Operation output (optional)

Terminal 7 / 8 During fan operation of the DX-Interface the dry contact between 7/8 is closed (Contact Rating 250VAC 8A). The fan operation will stop during defrosting and at the start of heating operation (Cold draft prevention). Please contact your local sales support if you want to fan operation to be continuous.

External safety contact

Terminal 9 / 10 If this contact is open for more than 1 minute, the error message P10 is generated and the DX-Interface switches off automatically (Rating 12VDC). This contact can, for instance, be used with an on-site frost protection monitor.

If the External safety contact is not used, then the contact should be bridged.

Inside device BUS line (U1 / U2 / \ominus)

Terminal U1 / U2 / \ominus Details regarding the wiring of the inside device BUS can be found in the installation manual of the VRF outdoor unit.

Remote control BUS line (A / B)

Terminal A / B At these terminals a second wired remote control can be optionally attached. The AB connection is used for GROUP control.

Temperature sensors

The refrigerant temperature sensors are inserted into the brazed sensor holders (There are 2 sizes of refrigerant Sensors: $\varnothing 4$ & $\varnothing 6$) and secured using the supplied FIX-PLATE (There are 2 sizes of FIX-PLATE). The sensor cables are to be attached as follows:

- | | | | |
|----------------|----------------------------------|----------------|--------------------------------------|
| Terminal 50/51 | TC1 Sensor $\varnothing 4$ (BRN) | Terminal 54/55 | TCJ Sensor $\varnothing 6$ (RED) |
| Terminal 52/53 | TC2 Sensor $\varnothing 6$ (BLK) | Terminal 56/57 | TA Resin Bulb Sensor / P-CLAMP (YEL) |

The sensor cables cannot be extended, they are supplied at the maximum permissible length of 5m.

Pulse modulated valve (PMV)

The connecting cable of the PMV is to be attached as follows:

- | | | | |
|-------------|--------|-------------|-------|
| Terminal 81 | WHITE | Terminal 84 | BLUE |
| Terminal 82 | YELLOW | Terminal 85 | BROWN |
| Terminal 83 | ORANGE | Terminal 86 | RED |

The PMV cable cannot be extended, it is supplied at the maximum permissible length of 5m.

■ ELECTRICAL CONNECTION (MM-DXC012)

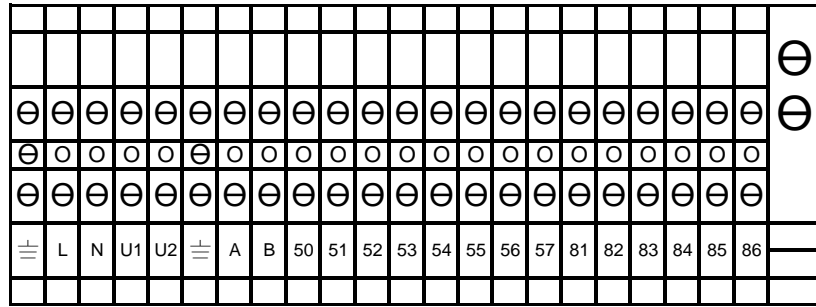

Supply

Terminal ≡ / L / N The controller should be connected to the main power supply by means of a switch with a contact separation of at least 3mm.

Inside device BUS line (U1 / U2 / ≡)

Terminal U1 / U2 / ≡ Details regarding the wiring of the inside device BUS can be found in the installation manual of the VRF outdoor unit.

Remote control BUS line (A / B)

Terminal A / B This control BUS line is used for GROUP control. During installation a wired remote controller needs to be connected to the A / B terminals to set DN codes.

Temperature sensors

The refrigerant temperature sensors are inserted into the brazed sensor holders (There are 2 sizes of refrigerant Sensors: Ø4 & Ø6) and secured using the supplied FIX-PLATE (There are 2 sizes of FIX-PLATE). The sensor cables are to be attached as follows:

- | | | | |
|----------------|---------------------|----------------|--------------------------------------|
| Terminal 50/51 | TC1 Sensor Ø4 (BRN) | Terminal 54/55 | TCJ Sensor Ø6 (RED) |
| Terminal 52/53 | TC2 Sensor Ø6 (BLK) | Terminal 56/57 | TA Resin Bulb Sensor / P-CLAMP (YEL) |

The sensor cables cannot be extended; they are supplied at the maximum permissible length of 5m.

Pulse modulated valve (PMV)

The connecting cable of the PMV is to be attached as follows:

- | | | | |
|-------------|--------|-------------|-------|
| Terminal 81 | WHITE | Terminal 84 | BLUE |
| Terminal 82 | YELLOW | Terminal 85 | BROWN |
| Terminal 83 | ORANGE | Terminal 86 | RED |

The PMV cable cannot be extended, it is supplied at the maximum permissible length of 5m.

■ 3-PIPE ELECTRICAL CONNECTION (SHRM / SHRMi / SHRMe)

The Flow selector units control must be wired directly to CN081 on the PCB (there are no dedicated connections on the Terminals).

On the MM-DXC010 to gain access to CN081 you first have to carefully remove the plastic cover over the PCB (4 wing nuts). Ensure to refit the cover when you have finished.

■ WIRING DIAGRAM (MM-DXC010)

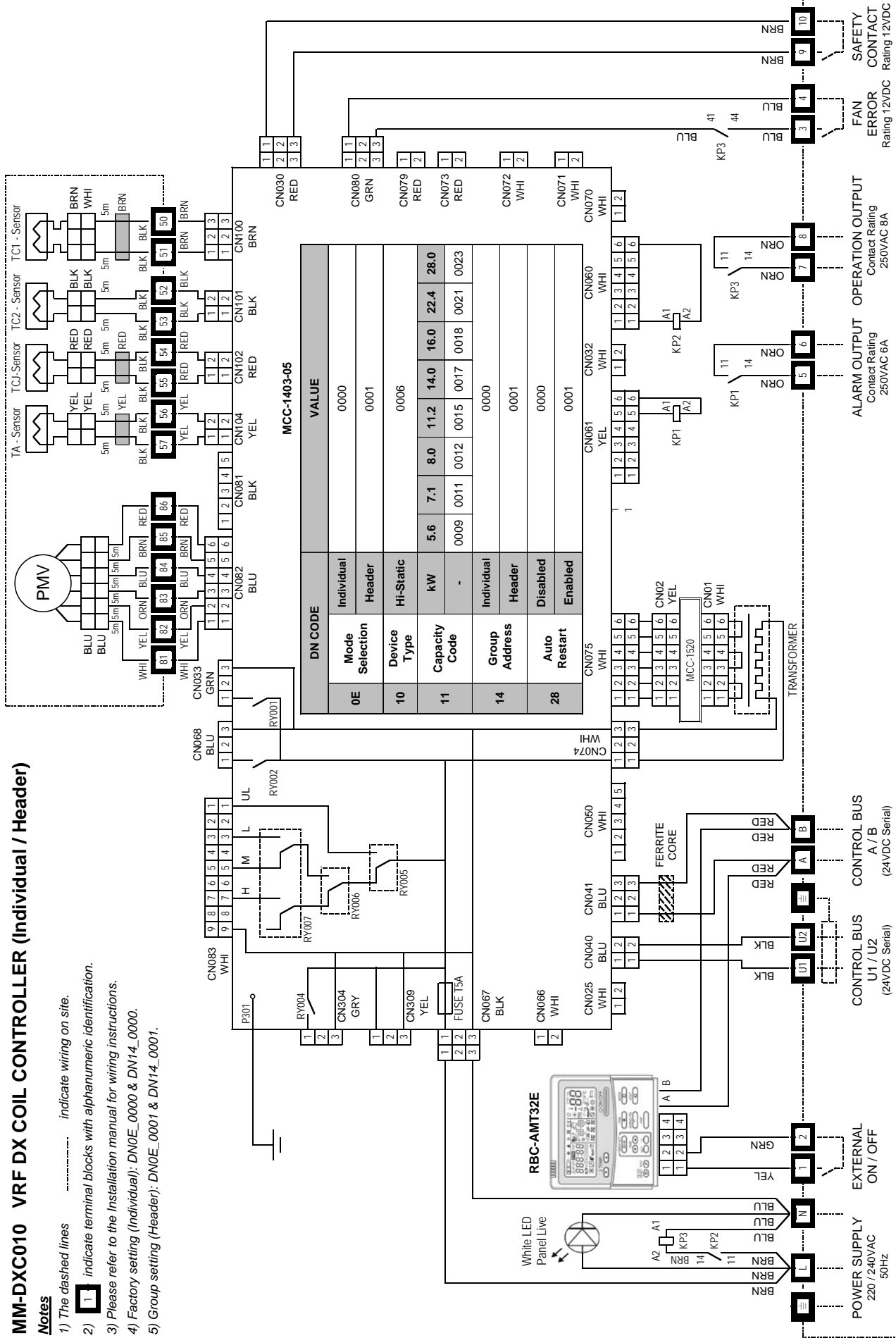

MM-DXC010 VRF DX COIL CONTROLLER (Individual / Header)

Notes

- 1) The dashed lines ----- indicate wiring on site.
- 2) [T] indicate terminal blocks with alphanumeric identification.
- 3) Please refer to the Installation manual for alphanumeric identification.
- 4) Factory setting (Individual): DN0E_0000 & DN14_0000.
- 5) Group setting (Header): DN0E_0001 & DN14_0001.

■ WIRING DIAGRAM (MM-DXC012)

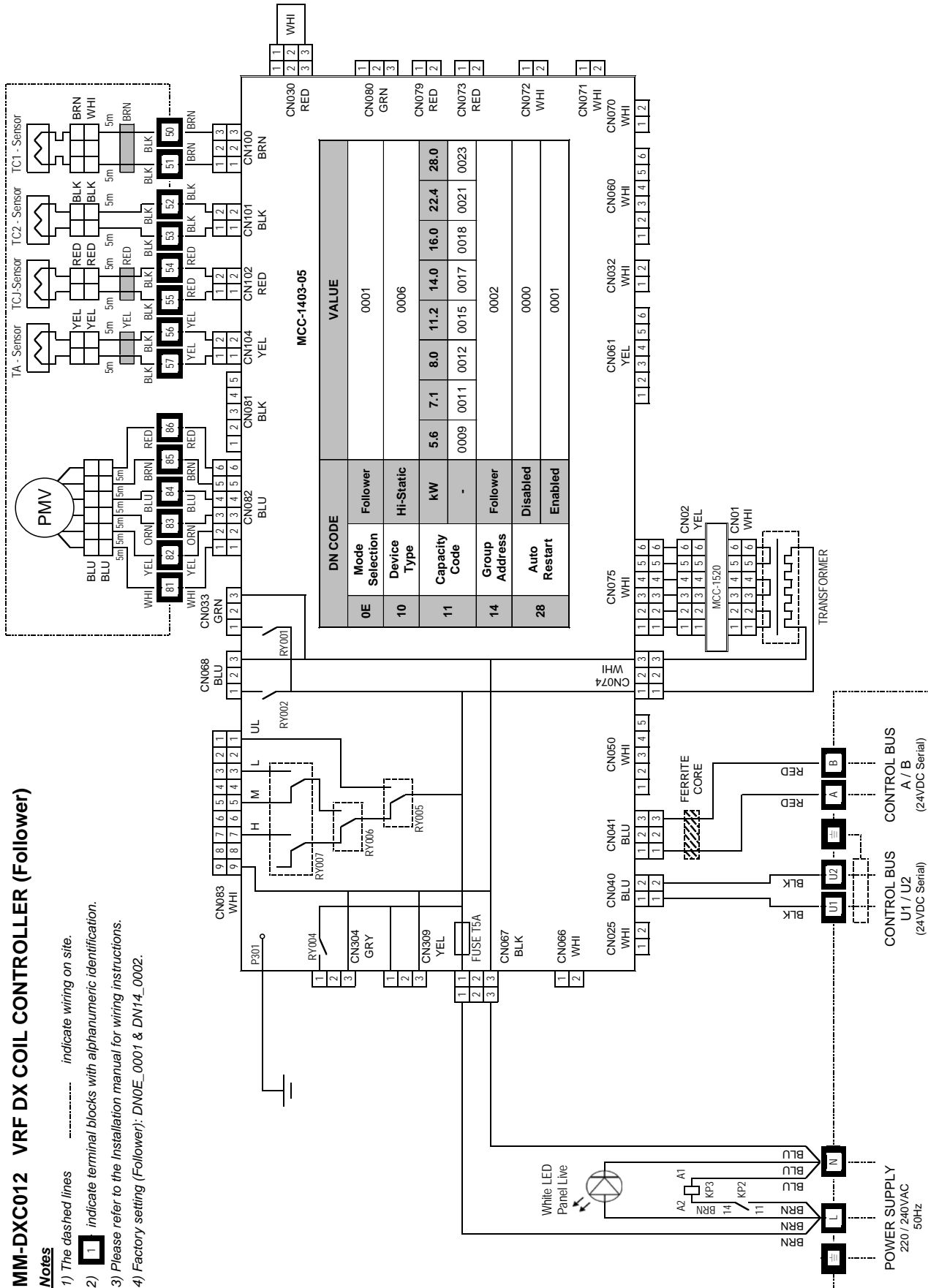

6 APPLICABLE CONTROLS

REQUIREMENT

- When you use this air conditioner for the first time, it takes approx. 5 minutes until the remote controller becomes available after power-on. This is normal.

<When the power is turned on for the first time after installation>

It takes **approx. 5 minutes** until the remote controller becomes available.

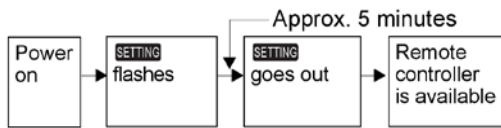

<When the power is turned on for the second (or later) time>

It takes **approx. 1 minute** until the remote controller becomes available.

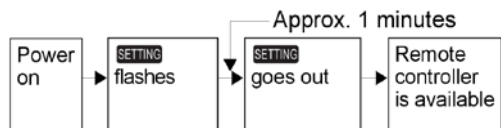

- Normal settings were made when the unit was shipped from factory. Change the indoor unit as required.
- Use the wired remote controller to change the settings.
- The settings cannot be changed using the wireless remote controller, sub remote controller, or remote controller-less system (for central remote controller only). Therefore, install the wired remote controller to change the settings.

Changing of settings for applicable controls

Basic procedure for changing settings

Change the settings while the air conditioner is not working.

(Be sure to stop the air conditioner before making settings).

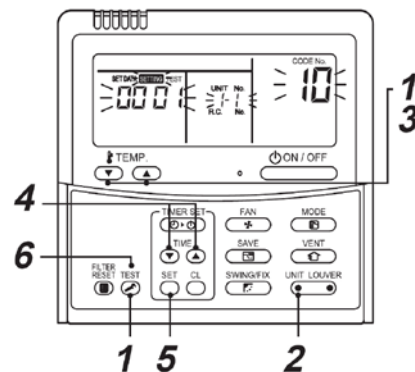

Procedure 1

Push **TEST** + **SET** + **CL** buttons simultaneously for at least 4 seconds.

After a while, the display flashes as shown in the figure.

Confirm that the CODE No. is [10].

- If the CODE No. is not [10] push **TEST** button to erase the display content and repeat the procedure from the beginning. (No operation of the remote controller is accepted for a while after **TEST** button is pushed). (While air conditioners are operated under the group control, "ALL" is displayed first. When **UNIT LOUVER** is pushed, the indoor unit number displayed following "ALL" is the header unit).

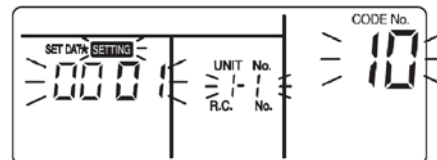

(* Display content varies with the indoor unit model).

Procedure 2

Each time you push  button, indoor unit numbers in the control group change cyclically. Select the indoor unit you want to change settings for. The fan of the selected unit runs and the louvers start swinging. You can confirm the indoor unit for which you want to change settings.

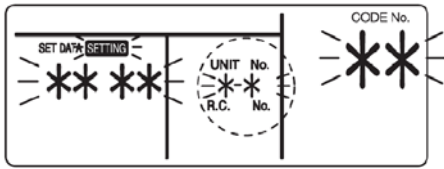

Procedure 3

Using "TEMP",  /  buttons, specify CODE NO. [**].

Procedure 4

Using timer "TIME"  /  buttons, select SET DATA [****].

Procedure 5

Push  button. When the display changes from flashing to lit, the setup is completed.

- To change settings of another indoor unit, repeat from procedure 2.
- To change other settings of the selected indoor unit, repeat from procedure 3.

Use  button to clear the settings.

To make settings after  button was pushed, repeat from procedure 2.

Procedure 6

When settings have been completed, push  button to determine the settings.

When  button is pushed, **SETTING** flashes and then the display content disappears and the air conditioner enters the normal stop mode.

(While **SETTING** is flashing, no operation of the remote controller is accepted).

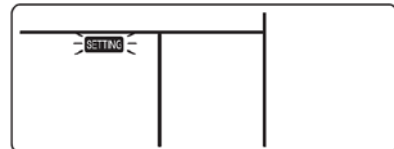

DX Coil Interface Configuration

The circuit board of the DX Controller is preconfigured during production. However DN 11 (Capacity Code) needs to be set by the installer. If the MM-DXC010 is used as a Header then DN 0E and DN 14 also need to be changed.

Follow to the basic operation Procedure (1 → 2 → 3 → 4 → 5 → 6).

Model	MM-DXC010			MM-DXC010			MM-DXC010	
	MM-DXV080			MM-DXV140			MM-DXV280	
Mode Selection (DN 0E)	0000* Individual			0000* Individual			0000* Individual	
	0001 Header			0001 Header			0001 Header	
Device type (DN 10)	0006*			0006*			0006*	
Cooling Capacity (kW)	5.6	7.1	8.0	11.2	14.0	16.0	22.4	28.0
Capacity Code (DN 11) **	0009	0011	0012	0015	0017	0018	0021	0023
Group address (DN 14)	0000* Individual			0000* Individual			0000* Individual	
	0001 Header			0001 Header			0001 Header	
Auto Restart (DN 28)	0000* Disabled			0000* Disabled			0000* Disabled	
	0001 Enabled			0001 Enabled			0001 Enabled	

Model	MM-DXC012			MM-DXC012			MM-DXC012	
	MM-DXV080			MM-DXV140			MM-DXV280	
Mode Selection (DN 0E)	0001*			0001*			0001*	
Device type (DN 10)	0006*			0006*			0006*	
Cooling Capacity (kW)	5.6	7.1	8.0	11.2	14.0	16.0	22.4	28.0
Capacity Code (DN 11) **	0009	0011	0012	0015	0017	0018	0021	0023
Group address (DN 14)	0002*			0002*			0002*	
Auto Restart (DN 28)	0000* Disabled			0000* Disabled			0000* Disabled	
	0001 Enabled			0001 Enabled			0001 Enabled	

* Default value (factory set).

** During production all DX Controllers are set to DN11_0009 for functional test.

7 TEST RUN

How to execute a test run

- Before turning on the power supply, carry out the following procedure.
 - Using 500V-Megger, check that the resistance of 1MΩ or more exists between the terminal block of the power supply and the earth (grounding).
If resistance of less than 1MΩ is detected, do not run the unit.
 - Check the valve of the outdoor unit being opened fully.
- To protect the compressor at activation time, leave power-ON for 12 hours or more before operating.
- Never press the electromagnetic contactor to forcibly perform the test run. (This is very dangerous because the protective device does not work).
- Before starting a test run, be sure to set addresses following the installation manual supplied with the outdoor unit.

How to execute a test run

Using the remote controller, operate the unit as usual.

A forced test run can be executed in the following procedure even if the operation stops by thermo-OFF.

In order to prevent a serial operation, the forced test run is released after 60 minutes have passed and returns to the usual operation.

CAUTION

- Do not use the forced test run for cases other than the test run because it applies excessive load to the devices.

In case of wired remote controller.

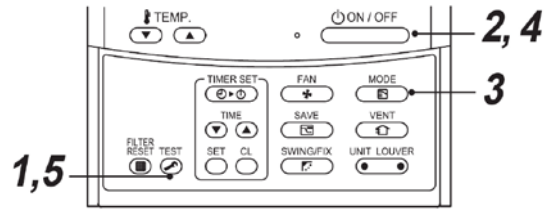

Procedure 1

Keep  button pushed for 4 seconds or more. [TEST] is displayed on the display part and the selection of mode in the test mode is permitted.

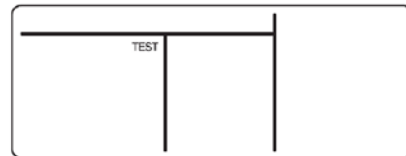

Procedure 2

Push  button.

Procedure 3

Using  button, select the operation mode, [❄️ COOL] or [🔥 HEAT].

- Do not run the air conditioner in a mode other than [❄️ COOL] or [🔥 HEAT].
- The temperature controlling function does not work during test run.
- The detection of errors is performed as usual.

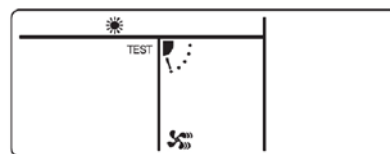

Procedure 4

After the test run, push  button to stop a test run. (Display part is same as procedure 1).

Procedure 5

Push  check button to cancel (release from) the test run mode. ([TEST] disappears on the display and the status returns to normal).

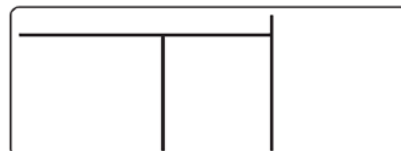

8 TROUBLE SHOOTING

Confirmation and Check

When a trouble occurred in the air conditioner, the check code and the indoor unit No. appear on the display part of the remote controller. The check code is only displayed during the operation. If the display disappears, operate the air conditioner according to the following "Confirmation of error history" for confirmation.

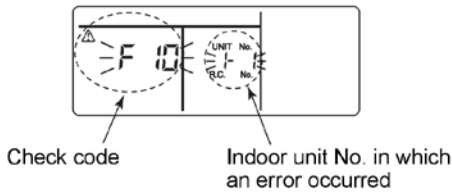

Confirmation of error history

When a trouble occurred on the air conditioner, the trouble can be confirmed with the following procedure. (The trouble history is stored up to 4 troubles.) The history can be confirmed from both operating status and stop status.

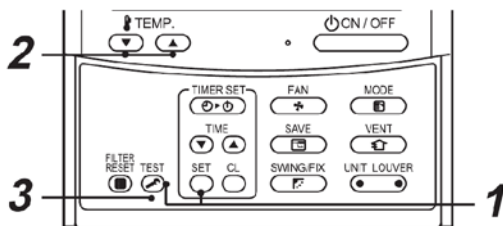

Procedure 1

When pushing **SET** and **TEST** buttons at the same time for 4 seconds or more, the following display appears.

If [service check] is displayed, the mode enters in the trouble history mode.

- [01: Order of trouble history] is displayed in CODE No. window.
- [Check code] is displayed in CHECK window.
- [Indoor unit address in which an error occurred] is displayed in Unit No.

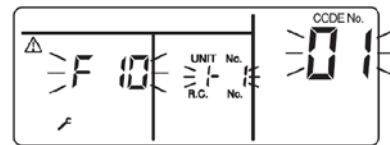

Procedure 2

Every pushing of "TEMP." button used to set temperature, the trouble history stored in memory is displayed in order. The numbers in CODE No. indicate CODE No. [01] (latest) → [04] (oldest).

REQUIREMENT

Do not push **CL** button because all of trouble history of the indoor unit will be deleted.

Procedure 3

After confirmation, push **TEST** button to return to the usual display.

Common Check Codes

- L09 Indoor unit Power Code incorrect**
Check the settings of DN Code 11 (see "DX Coil Interface Configuration").
- L30 Fan Motor operation monitor**
Check the operation monitoring of the fan at terminals 3 / 4. If this contact is "CLOSED", the error message "L30" is generated.
- P10 Safety contact error**
Check the contact at terminals 9 / 10. If the contact is "OPEN", the error message "P10" is generated. If this contact is not used, a bridge connection should be installed on the terminals 9 / 10.

A detailed description of all check codes can be found in the Toshiba Service manuals.

9 OPTIONAL PARTS

▼ Additional Remote controllers

RBC-AMT32E	Wired remote controller
TCB-EXS21TLE	Schedule and Weekly Timer accessory
RBC-AS21E2	Simplified wired remote controller for domestic and hotel application
RBC-AMS41E	Wired remote controller with weekly timer
RBC-AMS51E	Lite-Vision plus remote controller
TCB-AX32E2	Wireless remote controller and receiver



RBC-AMT32E



TCB-EXS21TLE



RBC-AS21E2



RBC-AMS41E



RBC-AMS51E



TCB-AX32E2

10 DECLARATION OF CONFORMITY

DECLARATION OF CONFORMITY

Manufacturer: Sarum Electronics Limited
Clump Farm Industrial Estate
Shaftesbury Lane
Blandford
DORSET
DT11 7TD
United Kingdom

According to the guidelines of the electromagnetic compatibility directive (2004/108/EC) and the low voltage directive (2006/95/EC) we declare that the product described below:

Generic Denomination: Air Conditioner
Model/type: MM-DXC010, MM-DXC012, MM-DXV080, MM-DXV140, MM-DXV280
Commercial name: VRF DX Coil Interface

Complies with the provisions of the following harmonized standard:

EN 50366: 2003 / A1: 2006
EN 55014-1:2006
EN 55014-2: 1997/A1:2001(category IV)
EN 61000-3-2:2006, EN 61000-3-3: 1995 / A1: 2001 / A2: 2005
EN 61000-3-11:2000, EN 61000-3-12:2005
EN 378-2: 2008
IEC 60335-2-40:2002 + A1 + A2
IEC 60335-1:2001 + A1 + A2

Note: This declaration becomes invalid if technical or operational modifications are introduced without the manufacturer's consent.

Signature:



Name: Steve Bishopp
Position: Managing Director
Date: 03-Dec-2012
Place Issued: United Kingdom

11 SERVICE PARTS

VRF DX Coil Controller (Individual / Header) - MM-DXC010

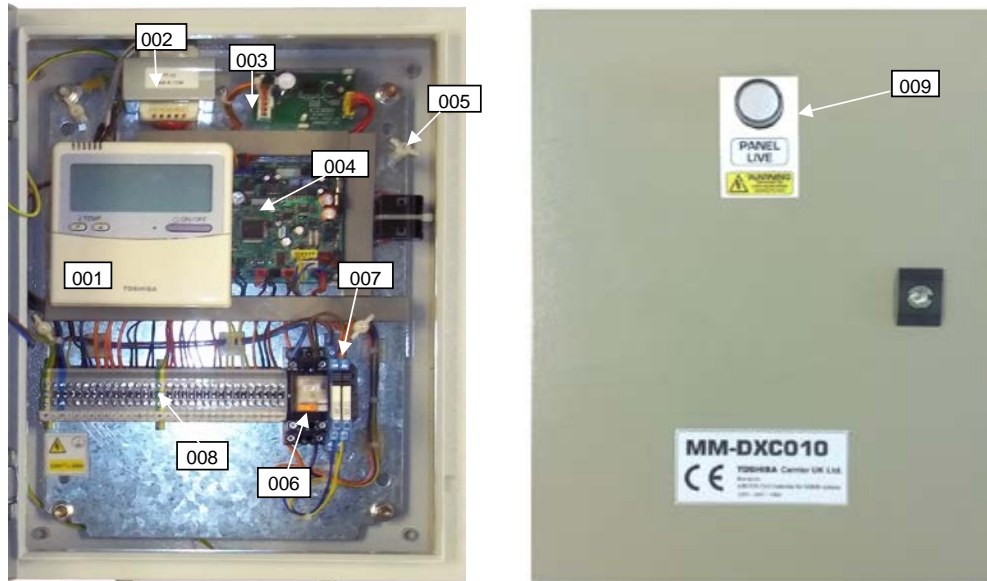

Location No.	Part No.	Description	Qty
001	RBC-AMT32E	Wired Remote Controller	1
002	43158187	Transformer	1
003	4316V247	Sub PCB MCC-1520-01	1
004	4316V326	Control PCB MCC-1403-05	1
005	43DX0001	Wing Nut	4
006	43DX0002	KP3 Relay (R2-230A)	1
	43DX0003	KP3 Relay Base (R2-T)	1
007	43DX0004	KP1/KP2 Relay & Base	2
008	43DX0005	Electrical Terminal (Grey)	29
	43DX0006	Electrical Terminal (Blue - Neutral)	1
	43DX0007	Electrical Terminal (Grn. / Yel. - Earth)	2
009	43DX0008	White Indicator Lamp (AD56LT-W)	1

VRF DX Coil Valve Kit - MM-DXV080, MM-DXV140 & MM-DXV280

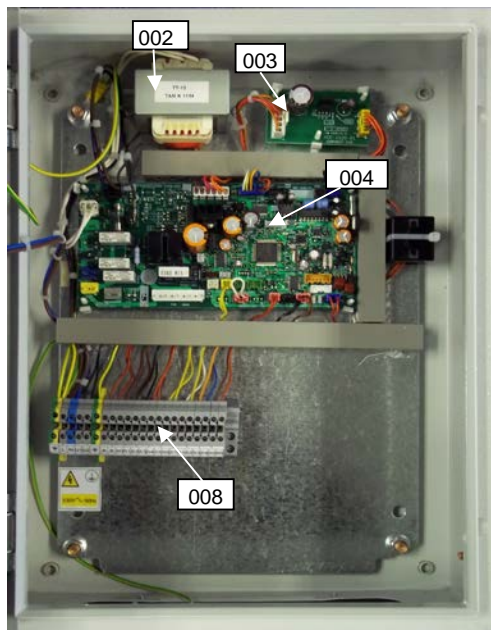

-	Part No.	Description	Qty
-	43150320	Sensor (Ø4 - TC1)	1
-	43050425	Sensor (Ø6 - TC2)	1
-	43050425	Sensor (Ø6 - TCJ)	1
-	43050426	TA Sensor	1
-	43146726	PMV Body (MM-DXV080)	1
-	43146723	PMV Body (MM-DXV140)	1
-	43146729	PMV Body (MM-DXV280)	1
-	43146743	PMV Motor	1
-	43163030	Sensor Holder (Ø4)	1
-	43149312	Sensor Holder (Ø6)	2
-	43107215	Fix Plate Sensor (Ø4)	1
-	43019904	Fix Plate Sensor (Ø6)	2
-	43A63001	P-Clip (TA)	1
-	4314Q051	Strainer	2

VRF DX Coil Controller (Follower) - MM-DXC012



Location No.	Part No.	Description	Qty
002	43158187	Transformer	1
003	4316V247	Sub PCB MCC-1520-01	1
004	4316V326	Control PCB MCC-1403-05	1
008	43DX0005	Electrical Terminal (Grey)	19
	43DX0006	Electrical Terminal (Blue - Neutral)	1
	43DX0007	Electrical Terminal (Grn. / Yel. - Earth)	2
009	43DX0008	White Indicator Lamp (AD56LT-W)	1

Toshiba Carrier (UK) Ltd
Porsham Close
Belliver Industrial Estate
Plymouth
Devon
United Kingdom
PL6 7DB

 +44 (0) 1752 753200
 +44 (0) 1752 753222