



The simple design of this unit represents the perfect choice, for refurbishment projects, where the available space is limited, or where neither the walls nor ceiling are able to house the unit.

CAPACITY SOUND PRESSURE LEVEL

0.8 HP < 2.5 HP

35dB(A)

OUTDOOR UNITS COMPATIBILITY

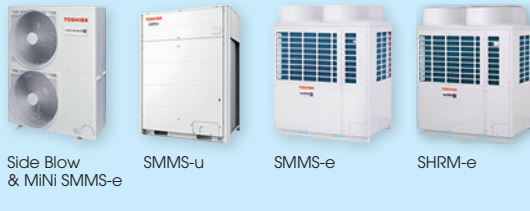

LOCAL CONTROLS



Features

Model name	MML-	UP0071H-E	UP0091H-E	UP0121H-E	UP0151H-E	UP0181H-E	UP0241H-E		
Capacity code	HP	0.8	1	1.3	1.7	2	2.5		
Cooling capacity	kW	2,2	2,8	3,6	4,5	5,6	7,1		
Heating capacity	kW	2,5	3,2	4	5	6,3	8		
Electrical characteristics	Power supply	1 phase 50Hz 220-240V / 1 phase 60Hz 220V (Separate power supply for indoor units is required.)							
	Running current	50 Hz	A	0,26		0,43		0,47	
		60 Hz	A	0,25		0,44		0,53	
	Power consumption	kW		0,056 / 0,044		0,092 / 0,069		0,102 / 0,076	
	Power factor	%		94 / 96		93 / 95		94 / 97	
	Starting current	A		0,60		0,80		1,10	
Appearance		Silky shade (1Y8.5/0.5)							
Outer dimension	HxLxP mm	630x950x230							
Total weight	kg	37							
Heat exchanger		Finned tube							
Soundproof/Heat-insulating material		Non-flammable insulation							
Fan unit	Fan	Centrifugal fan							
	Standard air flow (High/Mid./Low)	m³/h	480 / 420 / 360			900 / 780 / 650			1,080 / 930 / 780
	Motor output	W	45			70			
Sound pressure level (High/Mid./Low)	dB(A)	39 / 37 / 35			45 / 41 / 38			49 / 44 / 39	
Sound power level (High)	dB(A)	54			60			64	
Air filter		Standard filter (Simple filter)							
Controller		Remote controller							
Connecting pipe	Gas side	inch	3/8"	3/8"	3/8"	1/2"	1/2"	5/8"	
	Liquid side	inch	1/4"	1/4"	1/4"	1/4"	1/4"	3/8"	
	Drain port (Nominal dia.)	mm	20 (Polyvinyl chloride tube)						

Drawings

Unit: mm

All models

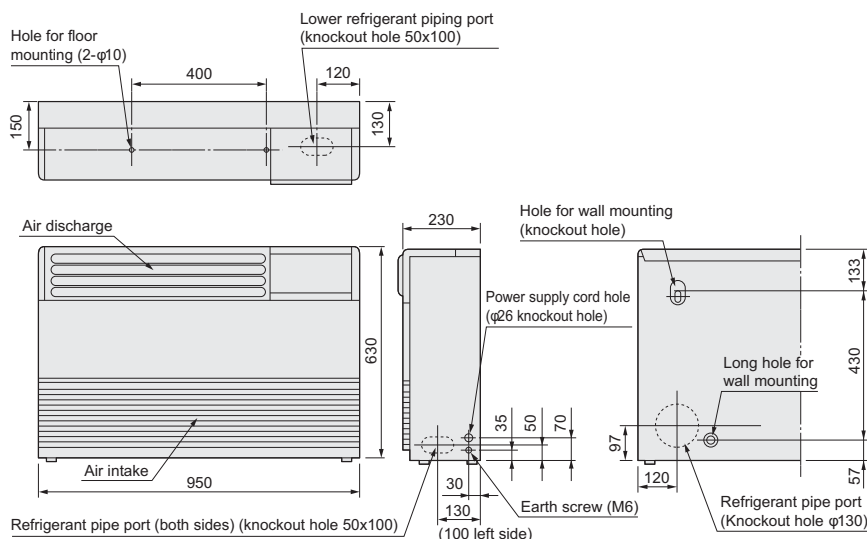

Sound pressure levels

Unit: dB(A)

MML-UP0071H-E, UP0091H-E

Fan tap	H	M	L
Sound pressure level (dB(A))	39	37	35

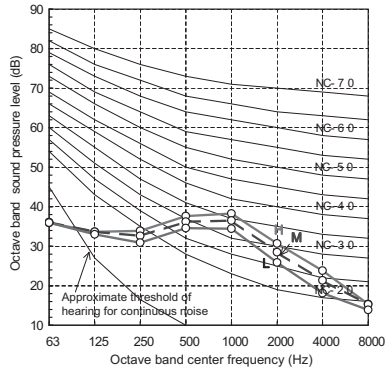

MML-UP0121H-E, UP0151H-E

Fan tap	H	M	L
Sound pressure level (dB(A))	45	41	38

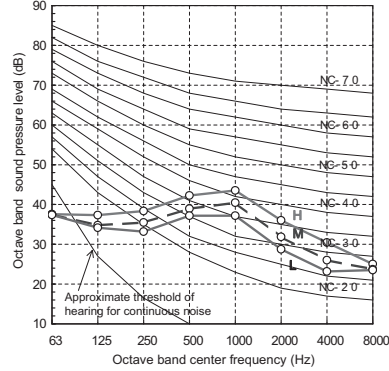

MML-UP0181H-E, UP0241H-E

Fan tap	H	M	L
Sound pressure level (dB(A))	49	44	39

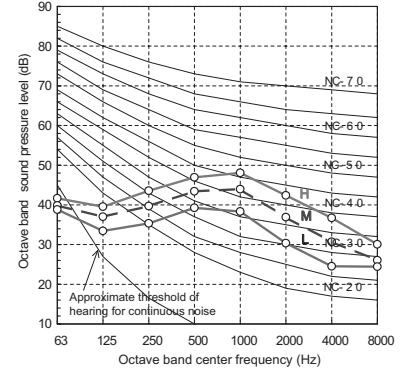

Air diffusion

Unit: m/s

MML-UP0071H-E, UP0091H-E

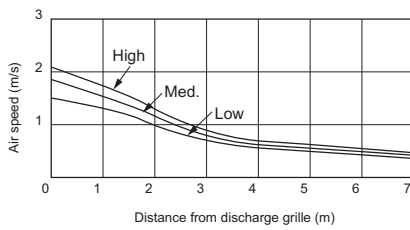

MML-UP0121H-E, UP0151H-E

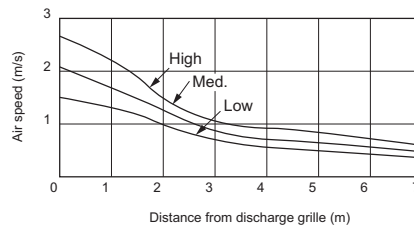

MML-UP0181H-E, UP0241H-E

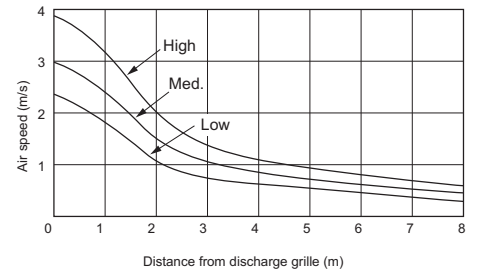

Console connectors

CN32	CN60	CN61	CN70	CN73	CN80
Additional ventilation control from remote control	Operation status signal output (cooling, heating, fan, defrost, thermo-on)	External On/Off, operation output and alarm output	Warning symbol on remote control based on signal input. No IDU thermo off.	Forced IDU thermo-off based on signal input	Forced IDU thermo-off and IDU lock based on signal input
•	•	•	•	•	•