

# TOSHIBA



EB99802801-1

## Installation Manual

---

### PMV Kit

# RBM-PMV0363E

# RBM-PMV0903E

Installation Manual  
PMV Kit

English

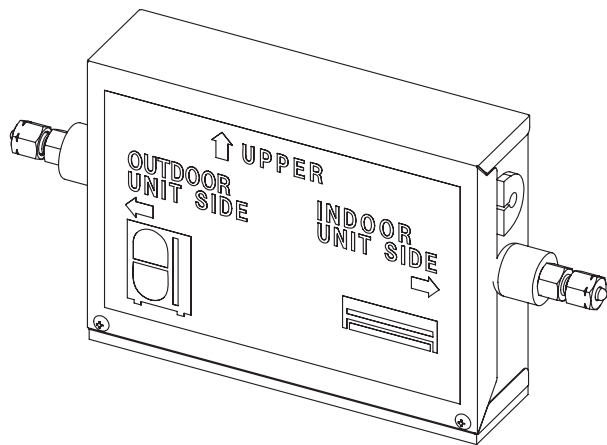

Thank you very much for purchasing TOSHIBA Air conditioner.

Please read this manual carefully before using your PMV Kit.

- When installing an indoor or outdoor unit, follow the installation manual supplied with the unit.
- To connect the PMV Kit to an outdoor unit with pipes, a branching joint or header is required. Choose one according to the capacity of the units.

### ADOPTION OF NEW REFRIGERANT







This air conditioner system is a new type which adopts a new refrigerant HFC (R410A) instead of the conventional refrigerant R22 in order to prevent destruction of the ozone layer. Be sure to use an indoor or outdoor unit in combination with the new refrigerant.

## CONTENTS

Accessory parts and Parts to be procured locally .....	2
<b>1</b> PRECAUTIONS FOR SAFETY .....	2
<b>2</b> INSTALLATION OF NEW REFRIGERANT AIR CONDITIONER .....	3
<b>3</b> SELECTION OF INSTALLATION PLACE .....	4
<b>4</b> INSTALLATION OF PMV KIT .....	4
<b>5</b> REFRIGERANT PIPING .....	5
<b>6</b> FIXATION AFTER CONNECTION PIPES .....	5
<b>7</b> ELECTRIC WORK .....	7
<b>8</b> SETUP OF OUTDOOR UNIT .....	10

## Accessory parts and Parts to be procured locally

### ■ Accessory parts

Part name	Q'ty RBM-		Shape	Usage
	PMV0363E	PMV0903E		
Installation Manual	1	1	This manual	(Hand over to customers)
Connection cable and Connector conversion cable (Connected to PMV Kit)	1	1		Connecting cable for PMV control
Heat insulating pipe	2	2		For heat insulating of liquid pipe connection section
Binding band L	2	2		For fixing of PMV Kit
Binding band M	5	5		For fixing of heat insulation pipe For fixing the clamp filter and lead wire
Binding band S	1	1		For bundling of wires
Attached joint and seal pipe	—	2		For connection of Ø9.5 refrigerant pipes
Clamp filter	1	1		All indoor units

## 1 PRECAUTIONS FOR SAFETY

- Ensure that installation work satisfy all Local, National International regulations.
- Read this "PRECAUTIONS FOR SAFETY" carefully before installation.
- The precautions described below include the important items regarding safety. Observe them without fail.
- After the installation work, perform a test operation to check for any problem. Follow the Owner's Manual to explain how to use and maintain the unit to the customer.
- Turn off the main power supply switch (or breaker) before the unit maintenance.
- Ask the customer to keep the Installation Manual together with the Owner's Manual.

### CAUTION

#### New Refrigerant Air Conditioner Installation

- **THIS PMV KIT ADOPTS THE NEW HFC REFRIGERANT (R410A) WHICH DOES NOT DESTROY OZONE LAYER.**

The characteristics of R410A refrigerant are ; easy to absorb water, oxidizing membrane or oil, and its pressure is approx. 1.6 times higher than that of refrigerant R22. Accompanied with the new refrigerant, refrigerating oil has also been changed. Therefore, during installation work, be sure that water, dust, former refrigerant, or refrigerating oil does not enter the refrigerating cycle.

To prevent charging an incorrect refrigerant and refrigerating oil, the sizes of connecting sections of charging port of the main unit and installation tools are changed from those for the conventional refrigerant. Accordingly, the exclusive tools are required for the new refrigerant (R410A).

For connecting pipes, use new and clean piping designed for R410A, and please care so that water or dust does not enter. Moreover, do not use the existing piping because there are problems with pressure-resistance force and impurity in it.

# 1 PRECAUTIONS FOR SAFETY

## ⚠ WARNING

- **Ask an authorized dealer or qualified installation professional to install/maintain the air conditioner.**  
Inappropriate installation may result in water leakage, electric shock or fire.
- **Turn off the main power supply switch or breaker before attempting any electrical work.**  
Make sure all power switches are off. Failure to do so may cause electric shock.
- **Connect the connecting wire correctly.**  
If the connecting wire is connected in a wrong way, electric parts may be damaged.
- **When moving the air conditioner for the installation into another place, be very careful not to enter any gaseous matter other than the specified refrigerant into the refrigeration cycle.**  
If air or any other gas is mixed in the refrigerant, the gas pressure in the refrigeration cycle becomes abnormally high and it as a result causes pipe burst and injuries on persons.
- **Do not modify this unit by removing any of the safety guards or by by-passing any of the safety interlock switches.**
- **Exposure of unit to water or other moisture before installation may cause a short-circuit of electrical parts.**  
Do not store it in a wet basement or expose to rain or water.
- **After unpacking the unit, examine it carefully if there are possible damage.**
- **Do not install in a place that might increase the vibration of the unit.**
- **To avoid personal injury (with sharp edges), be careful when handling parts.**
- **Perform installation work properly according to the Installation Manual.**  
Inappropriate installation may result in water leakage, electric shock or fire.
- **When the air conditioner is installed in a small room, provide appropriate measures to ensure that the concentration of refrigerant leakage occur in the room does not exceed the critical level.**
- **Install the air conditioner securely in a location where the base can sustain the weight adequately.**
- **Perform the specified installation work to guard against an earthquake.**  
If the air conditioner is not installed appropriately, accidents may occur due to the falling unit.
- **If refrigerant gas has leaked during the installation work, ventilate the room immediately.**  
If the leaked refrigerant gas comes in contact with fire, noxious gas may generate.
- **After the installation work, confirm that refrigerant gas does not leak.**  
If refrigerant gas leaks into the room and flows near a fire source, such as a cooking range, noxious gas might generate.
- **Electrical work must be performed by a qualified electrician in accordance with the Installation Manual. Make sure the air conditioner uses an exclusive power supply.**  
An insufficient power supply capacity or inappropriate installation may cause fire.
- **Use the specified wires for wiring connect the terminals securely fix. To prevent external forces applied to the terminals from affecting the terminals.**
- **Conform to the regulations of the local electricity company when wiring the power supply.**  
Inappropriate grounding may cause electric shock.
- **Do not install the air conditioner in a location subject to a risk of exposure to a combustible gas.**  
If a combustible gas leaks, and stays around the unit, a fire may occur.

## ⚠ CAUTION

- **Tighten flare nuts using a torque wrench according to the specified method.**  
If the flare nuts are tightened too much, they may later break and cause refrigerant leak.

# 2 INSTALLATION OF NEW REFRIGERANT AIR CONDITIONER

This PMV Kit adopts the new HFC refrigerant (R410A) which does not deplete the ozone layer.

- R410A refrigerant is apt to be affected by impurity such as water, oxidizing membrane, or oils because the pressure of R410A refrigerant is higher than that of the former refrigerant by approx. 1.6 times. Accompanied with adoption of the new refrigerant, refrigerating oil has been also changed. Therefore pay attention so that water, dust, former refrigerant, or refrigerating oil does not enter into the refrigerating cycle of the new refrigerant air conditioner during installation work.
- To prevent from mixing of refrigerant or refrigerating oil, the size of charge port of the main unit or connecting section of installation tool differs from that of the air conditioner for the former refrigerant. Accordingly the exclusive tools are required for the new refrigerant (R410A) as shown below.
- For connecting pipes, use the new and clean piping materials so that water or dust does not enter.

## ■ Required tools and cautions on handling

It is necessary to prepare the tools and parts as described below for the installation work.

The tools and parts which will be newly prepared in the following items should be restricted to the exclusive use.

### Explanation of symbols

- : Newly prepared (It is necessary to use it properly exclusive to R410A separated from those for R22 or R407C.)
- : Former tool is available.

Used tools	Usage	Proper use of tools/parts
Gauge manifold	Vacuuming or charging of refrigerant and operation check	● Newly prepared, Exclusive to R410A
Charging hose		● Newly prepared, Exclusive to R410A
Charging cylinder	Charges refrigerant	Unusable (Use the Refrigerant charging balance.)
Gas leak detector	Checks gas leak	● Newly prepared
Vacuum pump	Vacuum drying	Usable if a counter-flow preventive adapter is attached
Vacuum pump with counter-flow preventive adapter	Vacuum drying	○ : R22 (Existing article)
Flare tool	Flare processing of pipes	○ : Usable by adjusting size
Bender	Bending processing of pipes	○ : R22 (Existing article)
Refrigerant recovery device	Recovers refrigerant	● Exclusive to R410A
Torque wrench	Tightens flare nut	● Newly prepared, exclusive to Ø12.7mm and Ø15.9mm
Pipe cutter	Cuts pipes	○ : R22 (Existing article)
Brazing machine/ Nitrogen gas cylinder	Brazing of pipes	○ : R22 (Existing article)
Refrigerant charging balance	Charges refrigerant	○ : R22 (Existing article)

## ■ Refrigerant piping

- Piping material used for the conventional refrigerant cannot be used.
- Use copper pipe with 0.8mm or more thickness for Ø6.4, Ø9.5, Ø12.7mm.
- Flare nut and flare works are also different from those of the conventional refrigerant. Take out the flare nut attached to the unit of the air conditioner, and use it.

# 3 SELECTION OF INSTALLATION PLACE

## ⚠ CAUTION

**Do not install the air conditioner at place where combustible gas may leak.**

If gas leaks and is collected at surrounding the unit, the production of fire may be caused.

**Upon customer's approval, install the air conditioner at a place where satisfies the following conditions.**

- Place where it can be installed horizontally.
- Place which can reserve a service space for safe maintenance or check.
- Place where there is no problem even if the drained water flows.

**Apply electric insulation between metal section of the building and metal section of the air conditioner in conformance with the Local Regulation.**

**Avoid the following places.**

- Salty place (seaside area) or place with much gas sulfide (hot spring area)  
(If selecting such a place, a special maintenance is required.)
- Place where oil (including machine oil), steam, oil smoke or corrosive gas generates.
- Place where a device generating high frequency (inverter, non-utility generator, medical apparatus, or communication equipment) is set.  
(A bad influence may generate by malfunction of the air conditioner, control error, or noise for such equipment.)

## ■ Installation space

- Make space for installation and service. (Make space to the electrical parts box cover side for service.)
- When installing the unit inside the ceiling, be sure to create a check port.  
The check port is required when the unit is installed and serviced. (Check port: 450 × 450 or more)
- Keep a clearance of 50 mm or more between the top panel of the unit and the ceiling.
- The length of a connection pipe to the indoor unit should be 2 m to 10 m.

### Installation space

**RBM-PMV0363E, RBM-PMV0903E**

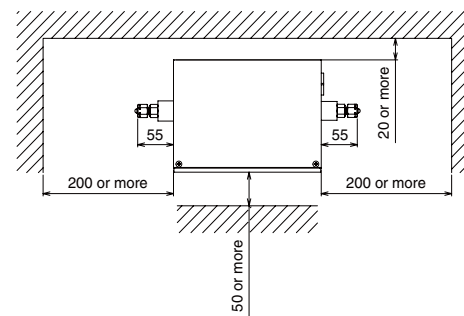

**RBM-PMV0903E (When attached joint is used)**

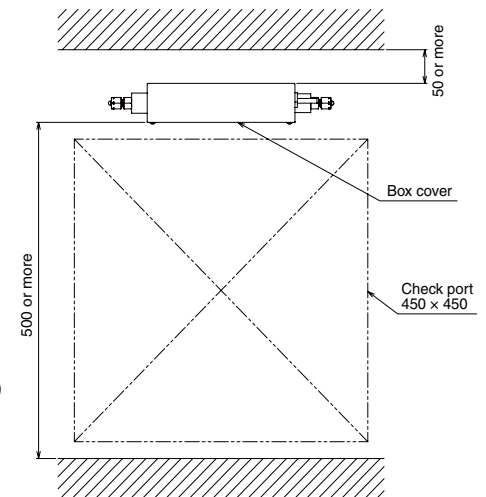
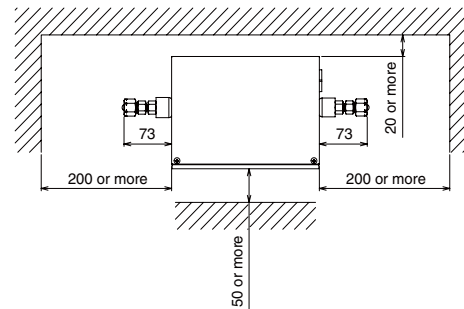

# 4 INSTALLATION OF PMV KIT

## ⚠ WARNING

Install the unit securely in the place to sufficiently withstand the weight of the unit.

If the foundation is not sturdy enough, the unit may fall and cause personal injury.

Perform a specified installation work to guard against earthquake.

Improper installation may cause the unit to fall.

## REQUIREMENT

To prevent damage on the PMV Kit or personal injury, follow the instructions below.

- Do not step, or put any heavy object on the packed PMV Kit.
- When carrying the PMV Kit, hold the two hanging brackets and be careful not to apply excessive force to the refrigerant pipes.

## External view

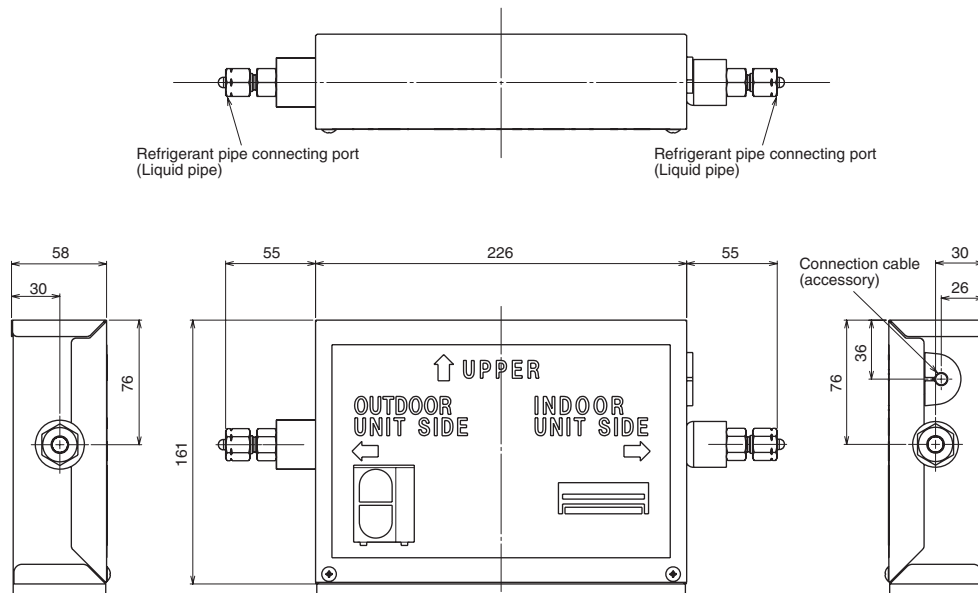

# 5 REFRIGERANT PIPING

## ⚠ WARNING

If refrigerant gas has leaked during the installation work, ventilate the room immediately.

If the leaked refrigerant gas comes in contact with fire, noxious gas may be generated.

After the installation work, confirm that refrigerant gas does not leak.

If refrigerant gas leaks into the room and flows near a fire source, such as a fan heater, cooking stove or heating unit, noxious gas may be generated.

## ■ Allowable length of refrigerant piping

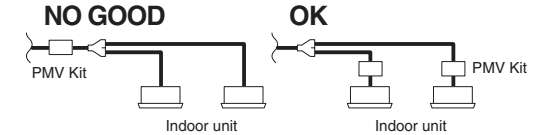
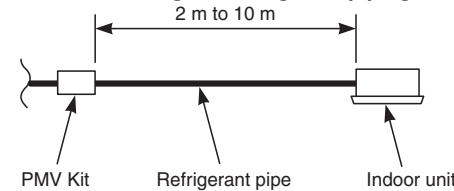

## • Connecting direction of refrigerant pipe

When connecting pipes, be careful of direction of the main unit.

Be sure to install the main unit so that [↑UPPER] mark in the label directs upward. For connection of the refrigerant pipes, follow the arrow mark in the label and connect pipes after confirming directions of indoor unit and outdoor unit.

## Note)

Do not connect two or more indoor units to one PMV Kit. Arrange one indoor unit and one PMV Kit set to 1 by 1.

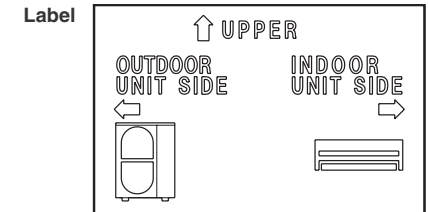

## Piping material and dimensions

Model name	Indoor unit capacity type	Diameter of refrigerant pipe	Notes
RBM-PMV0363E	005, 007, 009, 012 type	Ø6.4	
	015, 018 type	Ø6.4	
RBM-PMV0903E	024, 027 type	Ø9.5	

## ⚠ CAUTION

When connecting Ø9.5 refrigerant pipes, be sure to insert a seal pipe between PMV main unit and the joint. If the seal pipe is not inserted, refrigerant leakage is caused.



# 5 REFRIGERANT PIPING

## ■ Pipe forming/End positioning

### ◆ Flaring

1. Cut the pipe by a pipe cutter.

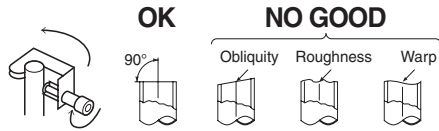

2. Insert a flare nut into pipe, and flare the pipe. As the flaring sizes of R410A differ from those of refrigerant R22, the flare tools newly manufactured for R410A are recommended. However, the conventional tools can be used by adjusting projection margin of copper pipe.

Flaring diam. Meter size:  
A (Unit: mm)

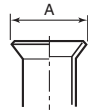

Outer dia. of copper pipe	A <sup>+0</sup> / <sub>-0.4</sub>
	R410A
6.4	9.1
9.5	13.2

\* In case of flaring for R410A with the conventional flare tool, pull it out approx. 0.5mm more than that for R22 to adjust to the specified flare size. The copper pipe gauge is useful for adjusting projection margin size.

Projection margin in flaring:  
B (Unit: mm)

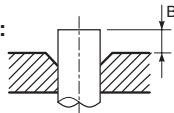

Rigid (Clutch type)

Outer dia. of copper pipe	R410A tool used	Conventional tool used
	R410A	R410A
6.4	0 to 0.5	1.0 to 1.5
9.5	0 to 0.5	1.0 to 1.5

Imperial (Wing nut type)

Outer dia. of copper pipe	R410A
6.4	1.5 to 2.0
9.5	1.5 to 2.0

## ■ Connection of refrigerant pipe

Connect all the refrigerant pipes with flare connecting work.

- Since the atmospheric pressure only is sealed as the sealing gas, it is not abnormal that "Pushu..." sound is not heard when the flare nut is removed.
- Be sure use two spanners for pipe connecting work of the indoor unit.

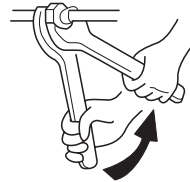

Work using two spanners

- Refer to the following table for tightening torque.

Connecting pipe outer dia. (mm)	Tightening torque (N m)	Re-tightening torque (N m)
Ø6.4	14 to 18 (1.4 to 1.8 kgf•m)	18 (1.8 kgf•m)
Ø9.5	33 to 42 (3.3 to 4.2 kgf•m)	42 (4.2 kgf•m)

## REQUIREMENT

If an excessive torque is applied, the nut may crack depending on the installation conditions.

## ■ Airtight test/Air purge, etc.

For airtight test, air purge, addition of refrigerant, and gas leak check, follow the Installation Manual attached to the outdoor unit.

## REQUIREMENT

Be sure to use the tool such as charge hose exclusive to R410A. Do not turn on the power until the airtight test and the vacuuming have finished. (If turning on the power, the incorporated PMV is closed fully and the period until the vacuuming finishes elongates.)

## ■ Open fully valves of the outdoor unit

## ■ Gas leak check

Check with a leak detector or soap water whether gas leaks or not, from the pipe connecting section or cap of the valve.

## REQUIREMENT

Use a leak detector manufactured exclusively for HFC refrigerant (R410A, R134a, etc.).

## ■ Heat insulating process

Perform heat insulating for pipes at liquid side and gas side separately.

In cooling time, temperature at both liquid and gas sides becomes lower.

Therefore, perform heat insulating process sufficiently to avoid dewing.

- For heat insulator of pipe at gas side, be sure to use one with heat-resisting temp. 120°C or more.
- Using the attached heat insulating pipe, perform heat insulating process securely for pipe connecting part of the PMV Kit without clearance.

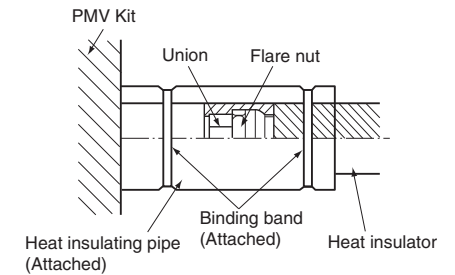

## REQUIREMENT

Apply the heat insulation to the pipe connecting section of the PMV Kit securely up to the root without exposure of the pipe. (The pipe exposed to the outside causes water leak.)

## 6 FIXATION AFTER CONNECTION PIPES

1. After connection to pipes, fix the PMV Kit using the attached binding band so that it is held closely to the gas pipe.

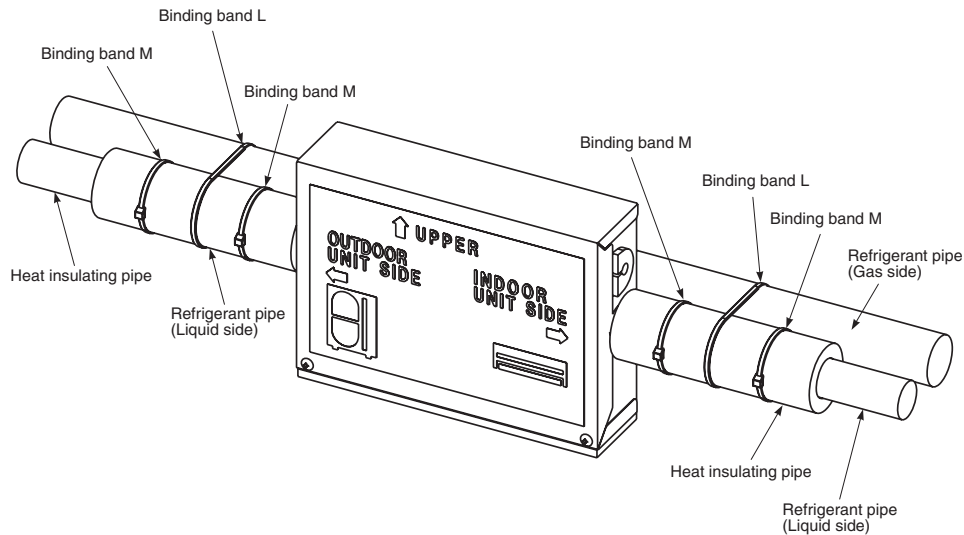

2. To avoid propagation of sound or vibration, wrap cushion material around the liquid pipes of PMV Kit, and then set with the hanging bolts within 1m intervals. Also, when mounting PMV Kit on the wall, put the cushion material between PMV Kit and the wall to avoid propagation of sound and vibration.

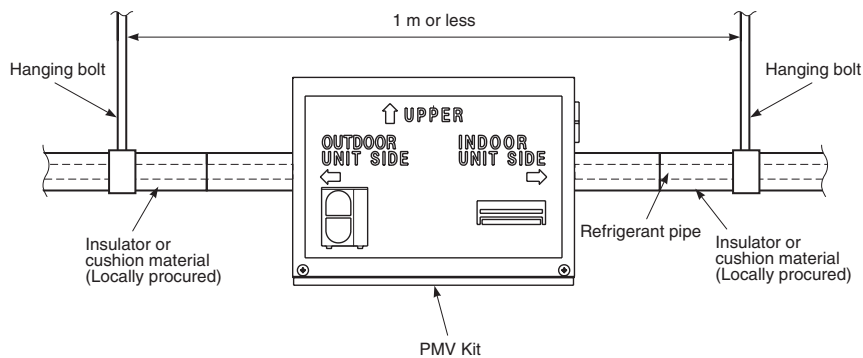

### Note

- Install PMV Kit as illustrated within 15 degree vertically and horizontally, respectively.

## 7 ELECTRIC WORK

### ⚠ WARNING

1. Using the specified wires, ensure to connect the wires, and fix wires securely so that the external strength of the wires do not transmit to the connecting part of the terminals. Incomplete connection or fixation may cause fire, etc.
2. For electric work, strictly follow to the Local Regulation in each country and the Installation Manual, and use an exclusive circuit. Capacity shortage of power circuit or incomplete installation may an electric shock or fire.

### REQUIREMENT

- Perform the electric wiring so that it does not come to contact with the high-temperature part of the pipe. The coating may melt resulted in an accident.
- After connecting wires to the terminal blocks, provide a trap and fix wires with the wire clamp.
- Store the refrigerant piping line and control wiring line in the same line.
- Do not turn on the power of the indoor unit until vacuuming of the refrigerant pipes completes.

# 7 ELECTRIC WORK

## ■ Wire connections

Use the supplied, dedicated wires.

### REQUIREMENT

- Check that power is not supplied to the indoor unit before connecting wires.
- Be sure to put wires through the wire connecting ports on the PMV Kit and the indoor unit.

**For this product, the connector conversion cable and additional clamp filter (Accessory) are used according to the indoor unit to be connected.**

For the corresponding unit and how to use the conversion cable and clamp filter, refer to the following description.

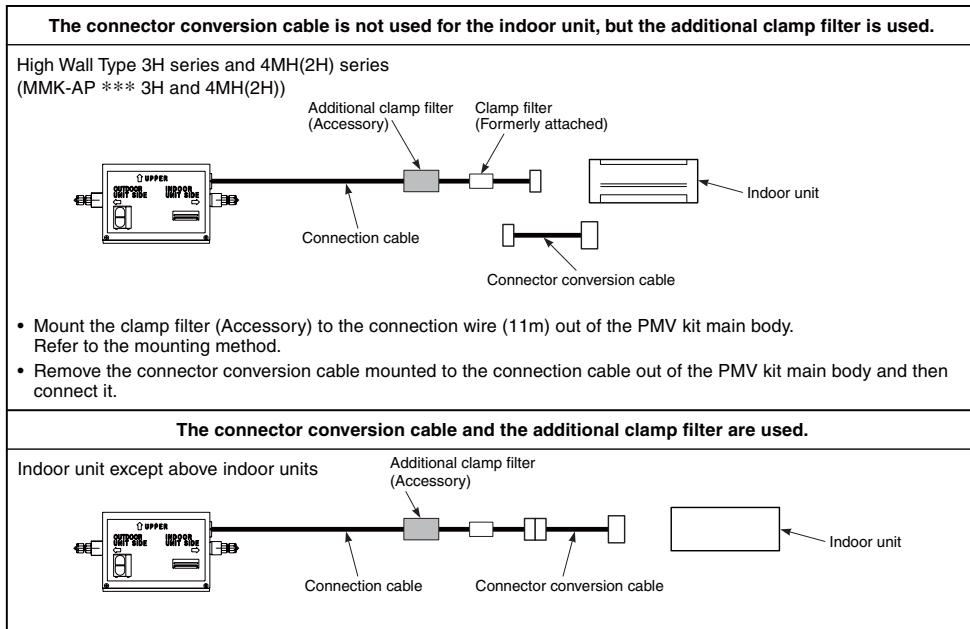

## • Work procedure 1

(In case of indoor unit which connector conversion cable is not used, but the additional clamp filter is used)

### ■ Applicable model: High wall type 4MH (2H) series

\* For 4MH-series models which have [E1] at the end of each model name, the works 1) and 2) are unnecessary.

- 1) Turn on power supply of the indoor unit only and open fully the pulse motor valve built in the indoor unit. Turn on power supply of the indoor unit only under condition that power supply of the outdoor unit is OFF.
  - \* If power supply of the outdoor unit is turned on, PMV of the indoor unit is not fully opened.

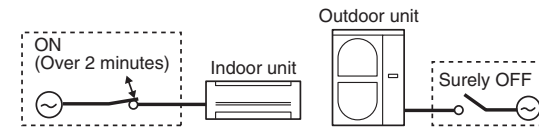

- 2) When 2 minutes or more passed after turning on power supply of the indoor unit, turn off power supply of the indoor unit.
  - \* Then PMV of the indoor unit has been fully opened. While this period, do not issue an operation instruction from the remote controller.
- 3) Mount the additional clamp filter to the connection cable.
  - ① Take off claws of clamp filter (Accessory) at 2 positions.
  - ② In the clamp filter, turn twice the connection cable out of the PMV kit main body. The mounting position is just side of the PMV kit main body of the already mounted clamp filter.

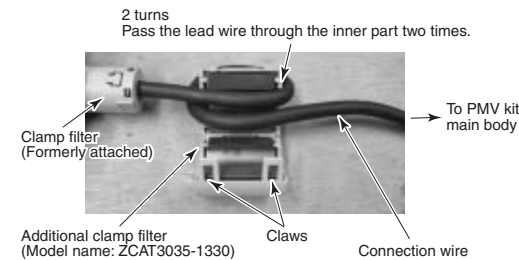

- ③ Tighten claws of the clamp filter securely and then lock it.
- ④ Use the attached bundling band to bundle the clamp filter together with

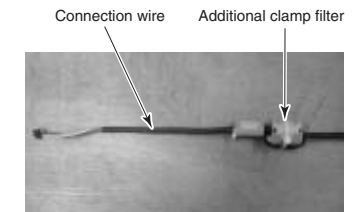
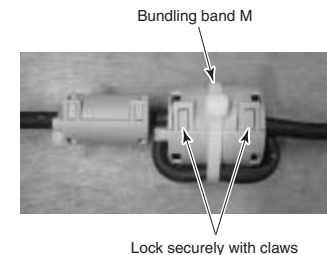

<Completed mounting drawing>



# 7 ELECTRIC WORK

4) Open the connector cover of the indoor unit after power-off and then process wiring work.

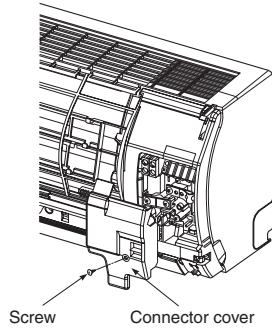

<Opening the connector cover for 4MH(2H) series>

- 5) Remove the connector conversion cable which is attached to the connection cable (11m) out of the box.
- 6) Replace the PMV connector built in the indoor unit with the connection cable of PMV Kit. The lock mechanism is provided at side of PMV connector. Remove the connector by releasing the lock mechanism. Fix the connection cable of PMV Kit with cord clamp for communication line.

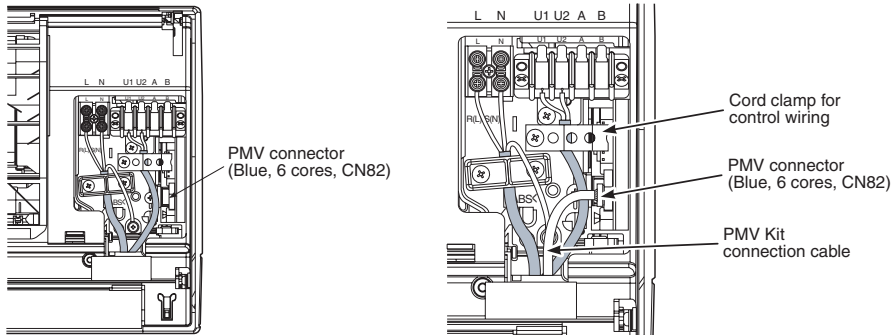

<Connecting control wire for 4MH(2H) series>

7) Mount the connector cover and then the work completes.

## • Work procedure 2

(In case of indoor unit which the connector conversion cable is not used, but the additional clamp filter is used)

### ■ Applicable model: High Wall type 3H series

\* For 3H-series models which have [E1] at the end of each model name, the works 1) and 2) are unnecessary.

Procedure 1) ,2) and 3) are same to the Work procedure those in Work procedure 1.

4) After turning off the power supply, remove the terminal cover and the clamp base.

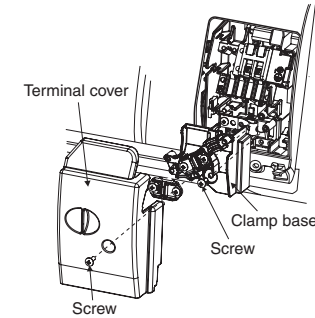

<Opening the connector cover for 3H series>

- 5) Replace the PMV connector built in the indoor unit with the connection cable of PMV Kit. The lock mechanism is provided at side of PMV connector. Remove the connector by releasing the lock mechanism. Fix the connection cable of PMV Kit with cord clamp for communication line.

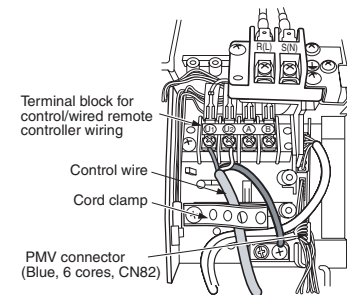

<Connecting control wire for 3H series>

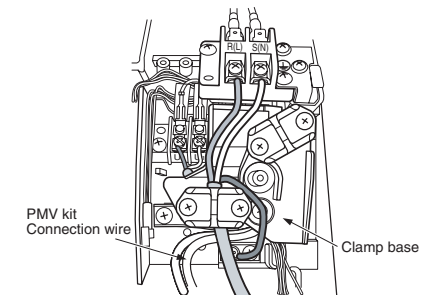

<Connecting power supply wire for 3H series>

6) Mount the clamp base and the terminal cover. The work has finished.

## 7 ELECTRIC WORK

### • Work procedure 3

(In case of indoor unit which additional clamp filter and the connector conversion cable are used)

#### ■ Applicable model: The all indoor units except High Wall type

The work procedures from 1), 2) and 3) are same to those in the work procedure 1.

- Attach the additional clamp filter near the indoor unit, and make sure the attach location is different depending on the indoor unit type.
- 4) Open the connector cover of the indoor unit after power-off and then process wiring work.
- 5) When the product was shipped from the factory, PMV connector built in the indoor unit is connected to CN82 connector of the indoor control PC board of the indoor unit. Therefore replace PMV connector with the connection cable of the PMV Kit.

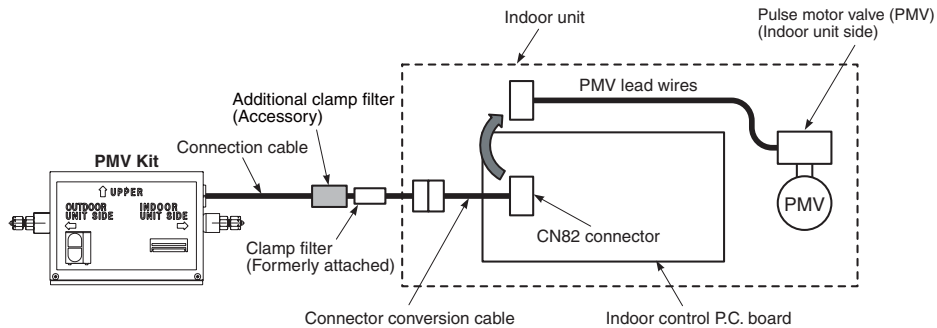

- 6) Using binding band, put together the removed PMV lead wires and then store in the electrical parts box.
- 7) Process the wiring work and then close the electrical parts box.

## 8 SETUP OF OUTDOOR UNIT

When using PMV Kit on the MiNi-SMMS system, it is necessary to set up DIP switches on the interface P.C. board of the outdoor unit.

If it is not MiNi-SMMS system, setting up of DIP switches is unnecessary.

#### ■ How to set up

- Turn DIP switch [SW08] on the interface P.C. board of the outdoor unit to ON side.

\* In a case that DIP switch [SW08] is not provided, the operation is unnecessary.

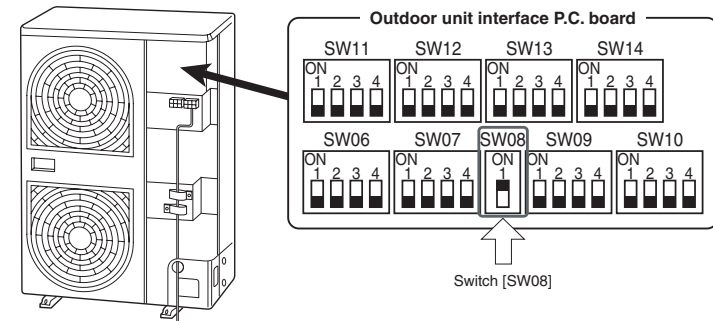



# **TOSHIBA CARRIER CORPORATION**

336, TADEHARA, FUJI-SHI, SHIZUOKA-KEN, 416-8521, JAPAN

**EB99802801-1**